

(*1) The number of channels varies depending on the model. Refer to the following information.
 DSP-R10: INPUT 1-144, MIX 1-72, MATRIX 1-36
 DSP-RX-EX: INPUT 1-288, MIX 1-72, MATRIX 1-36
 DSP-RX: INPUT 1-120, MIX 1-48, MATRIX 1-24
 CSD-R7: INPUT 1-144, MIX 1-60, MATRIX 1-36

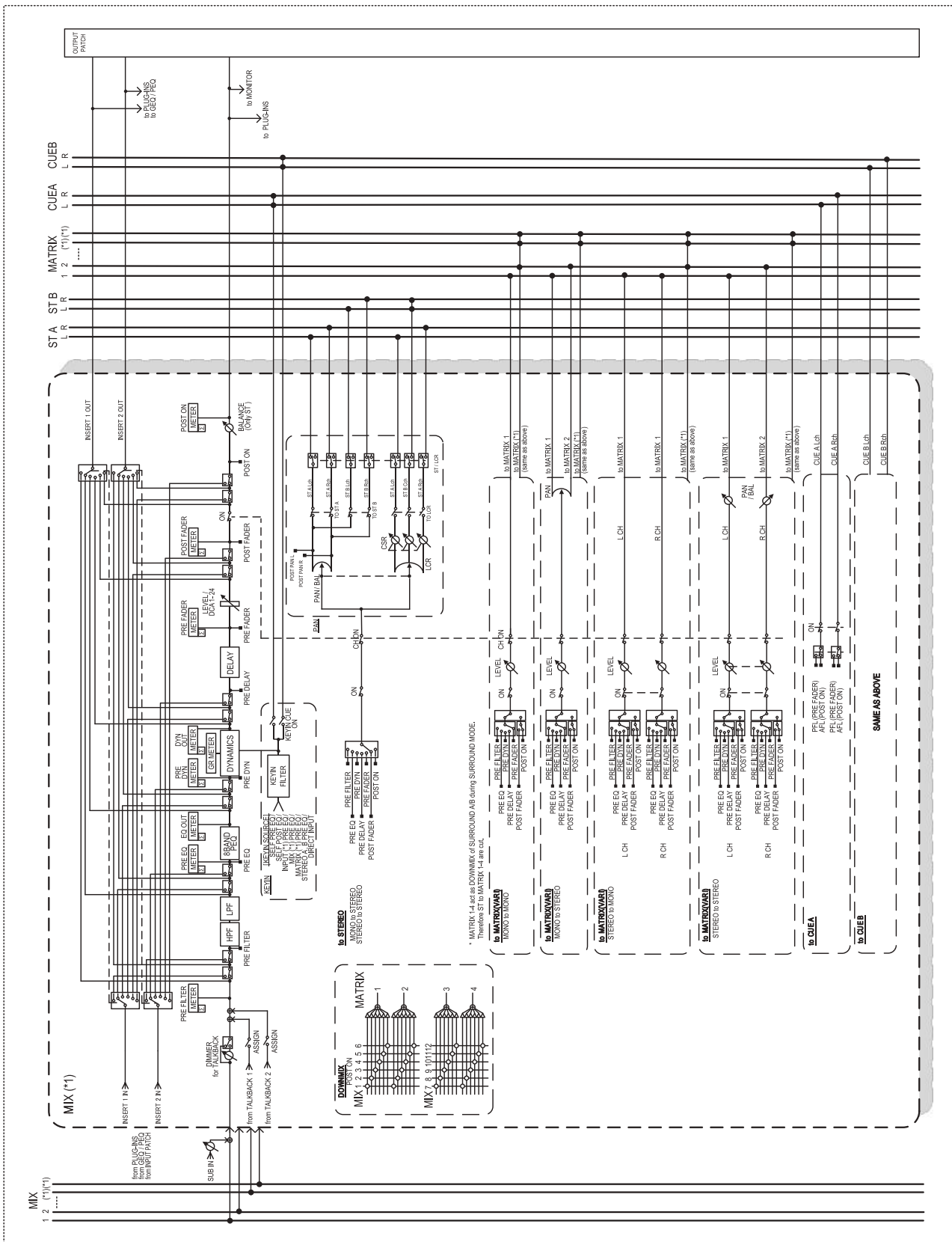

(*1) The number of channels varies depending on the model. Refer to the following information.
 DSP-R10: INPUT 1-144, MIX 1-72, MATRIX 1-36
 DSP-RX-EX: INPUT 1-288, MIX 1-72, MATRIX 1-36
 DSP-RX: INPUT 1-120, MIX 1-48, MATRIX 1-24
 CSD-R7: INPUT 1-144, MIX 1-60, MATRIX 1-36

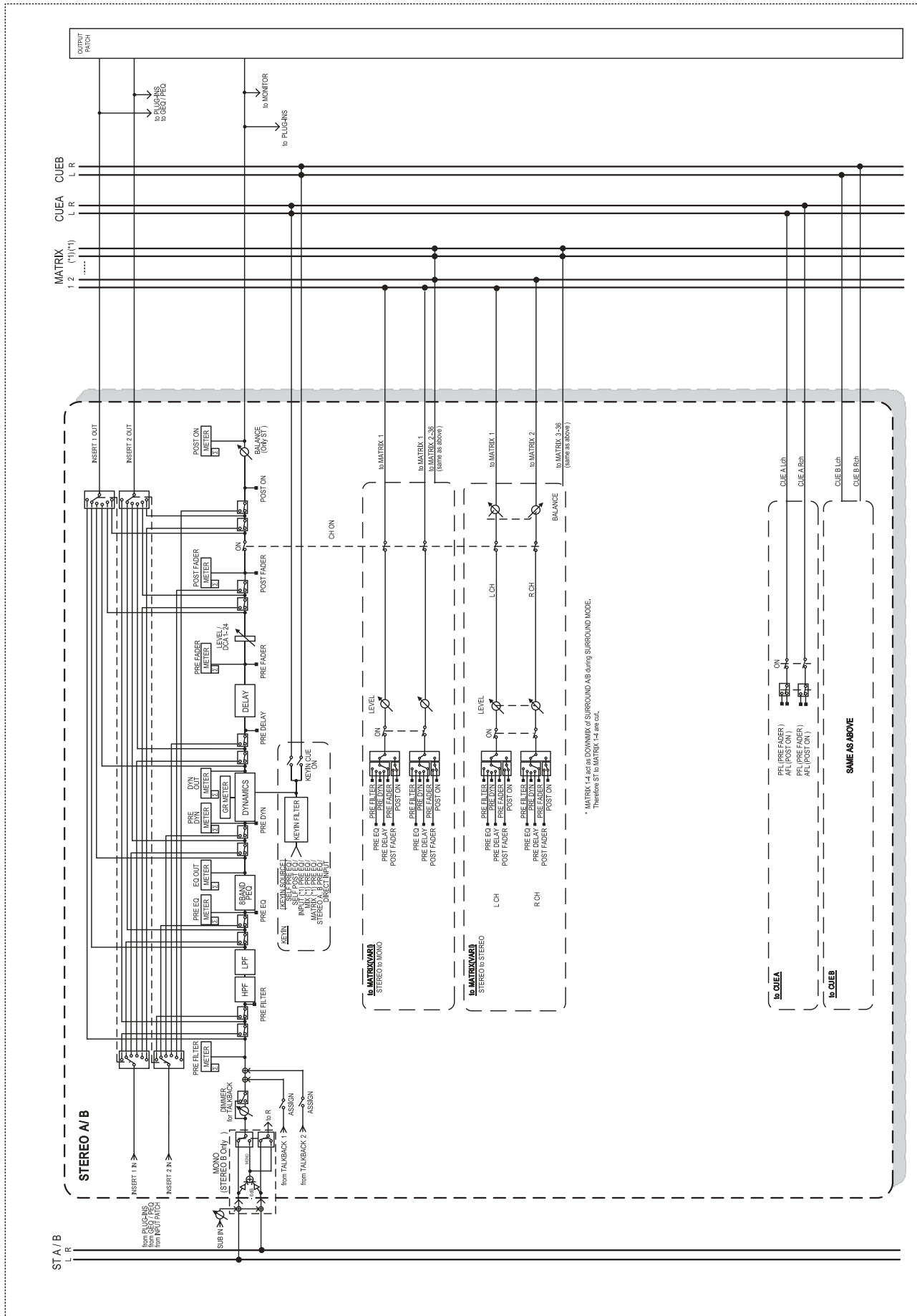

(*) The number of channels varies depending on the model. Refer to the following information.
 DSP-R10: INPUT 1-144, MIX 1-72, MATRIX 1-36
 DSP-RX-EX: INPUT 1-288, MIX 1-72, MATRIX 1-36
 DSP-RX: INPUT 1-120, MIX 1-48, MATRIX 1-24
 CSD-R7: INPUT 1-144, MIX 1-60, MATRIX 1-36

* MATRIX 1-4 to 36 (CONTRIK of SURROUND 1/8 during SURROUND MODE. Therefore ST to MATRIX 1-4 are cut.

SAME AS ABOVE

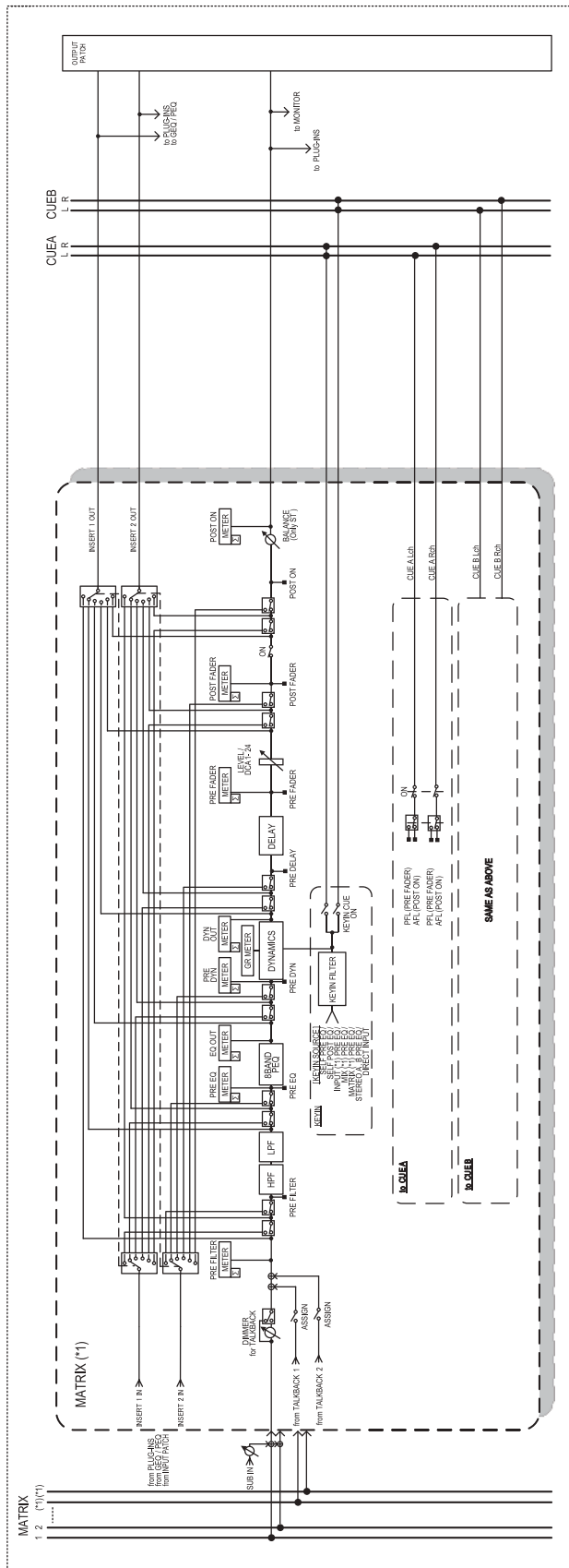

(*) The number of channels varies depending on the model. Refer to the following information.

- DSP-R10: INPUT 1-144, MIX 1-72, MATRIX 1-36
- DSP-RX-EX: INPUT 1-288, MIX 1-72, MATRIX 1-36
- DSP-RX: INPUT 1-120, MIX 1-48, MATRIX 1-24
- CSD-R7: INPUT 1-144, MIX 1-60, MATRIX 1-36

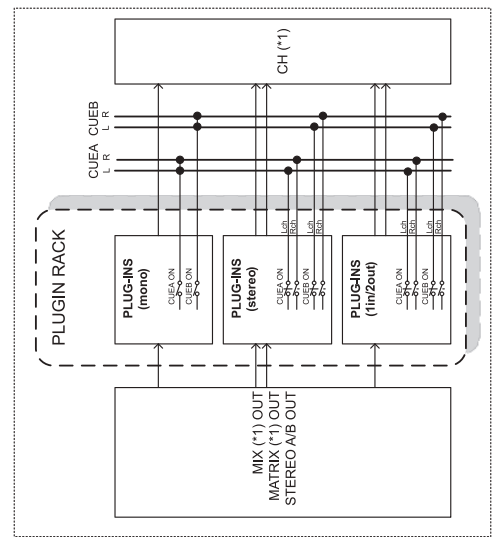

(*) The number of channels varies depending on the model. Refer to the following information.
 DSP-R10: INPUT 1-144, MIX 1-72, MATRIX 1-36
 DSP-RX-EX: INPUT 1-288, MIX 1-72, MATRIX 1-36
 DSP-RX: INPUT 1-120, MIX 1-48, MATRIX 1-24
 CSD-R7: INPUT 1-144, MIX 1-60, MATRIX 1-36

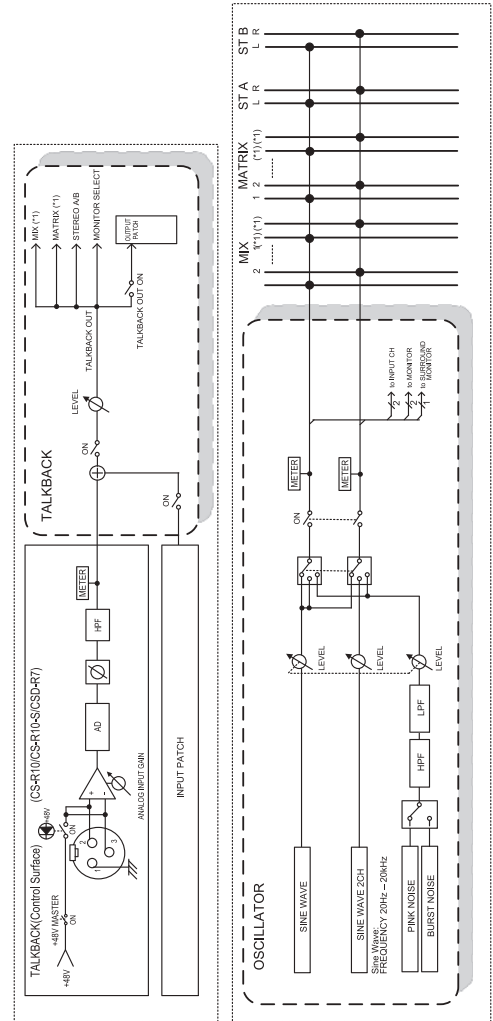

DM7 [DM7 Compact]

CH 1-120 [72]

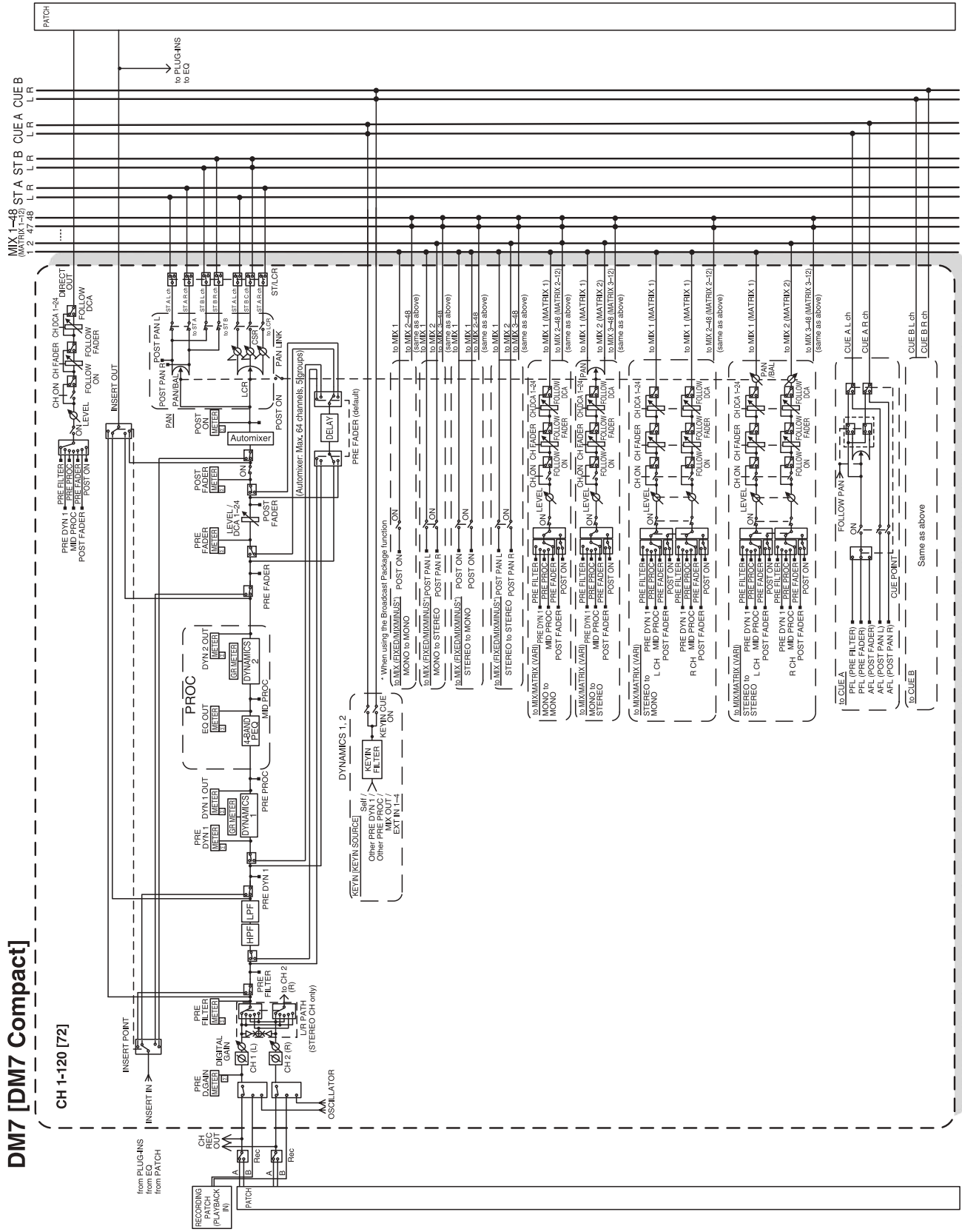

Block Diagram: DM7 Series 2/6

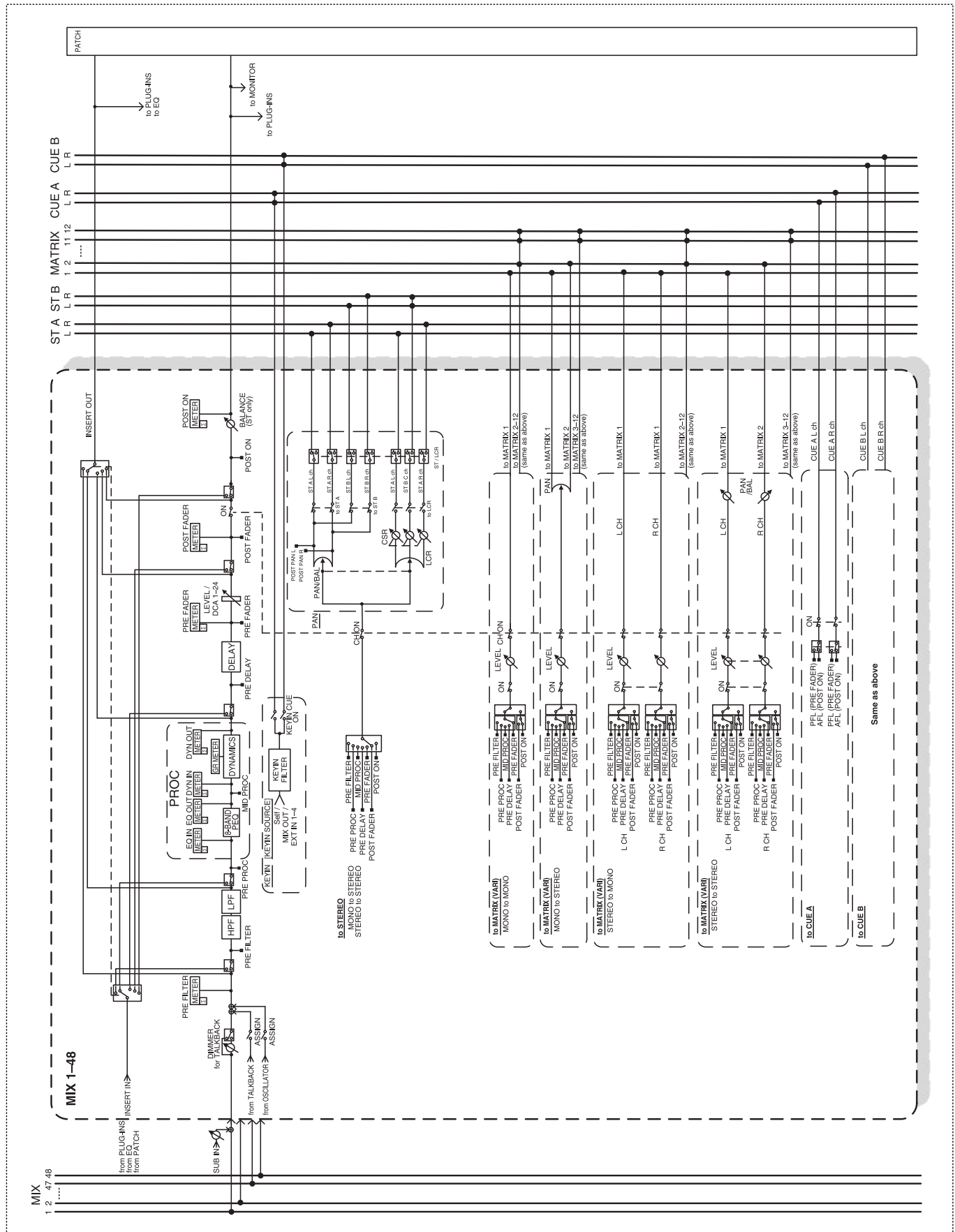

Block Diagram: DM7 Series 3/6

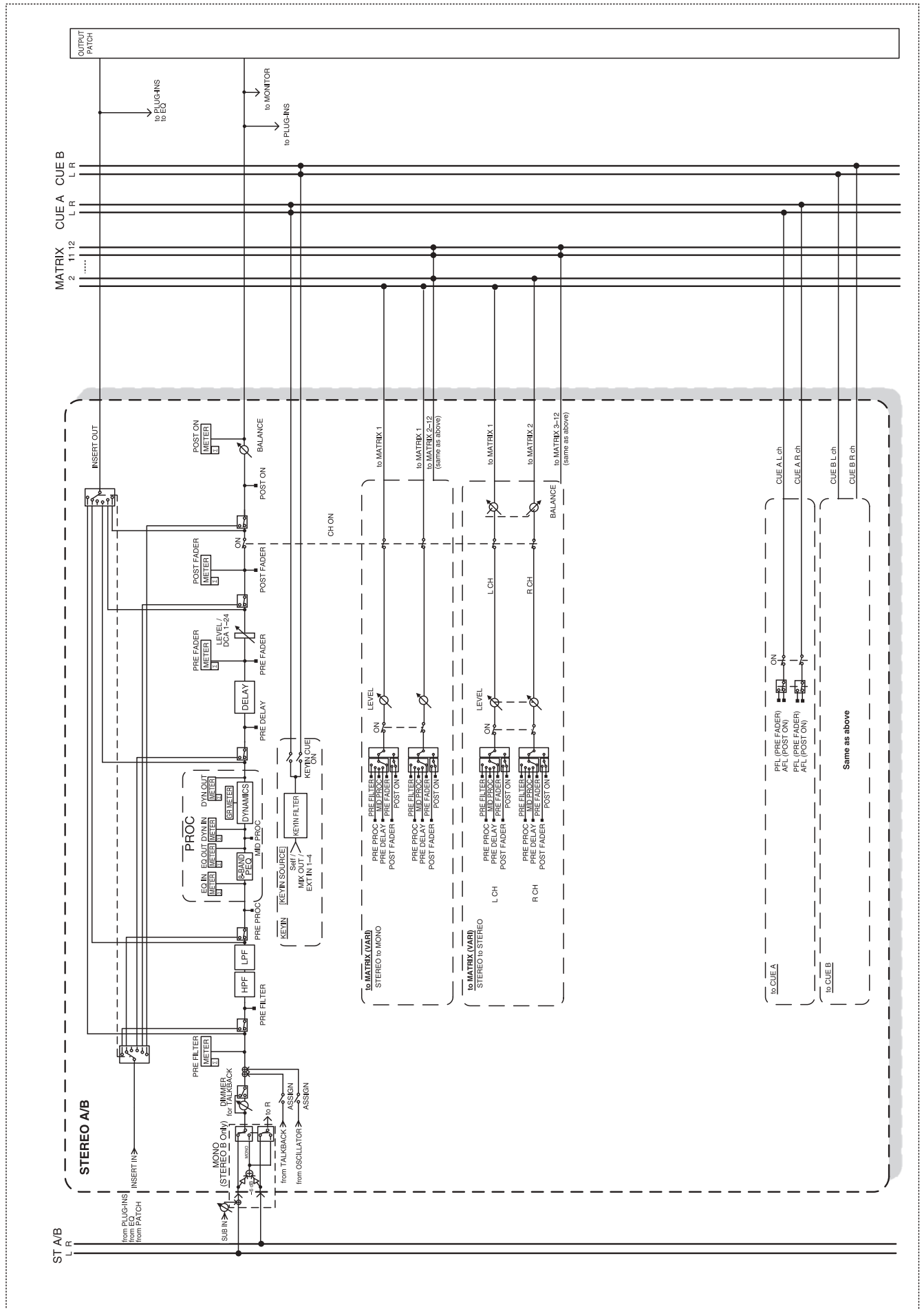

Block Diagram: DM7 Series 4/6

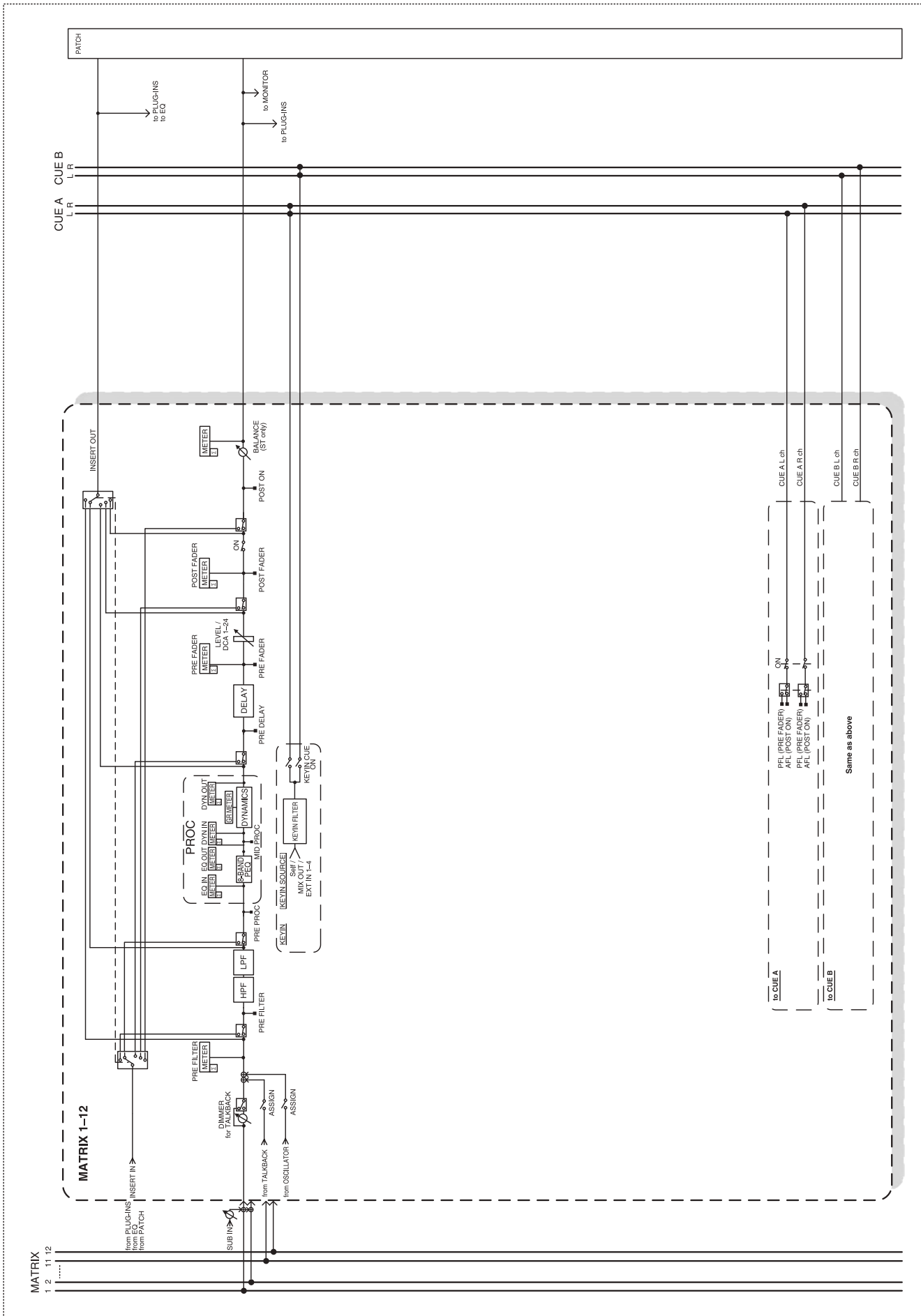

Block Diagram: CL Series 1/2

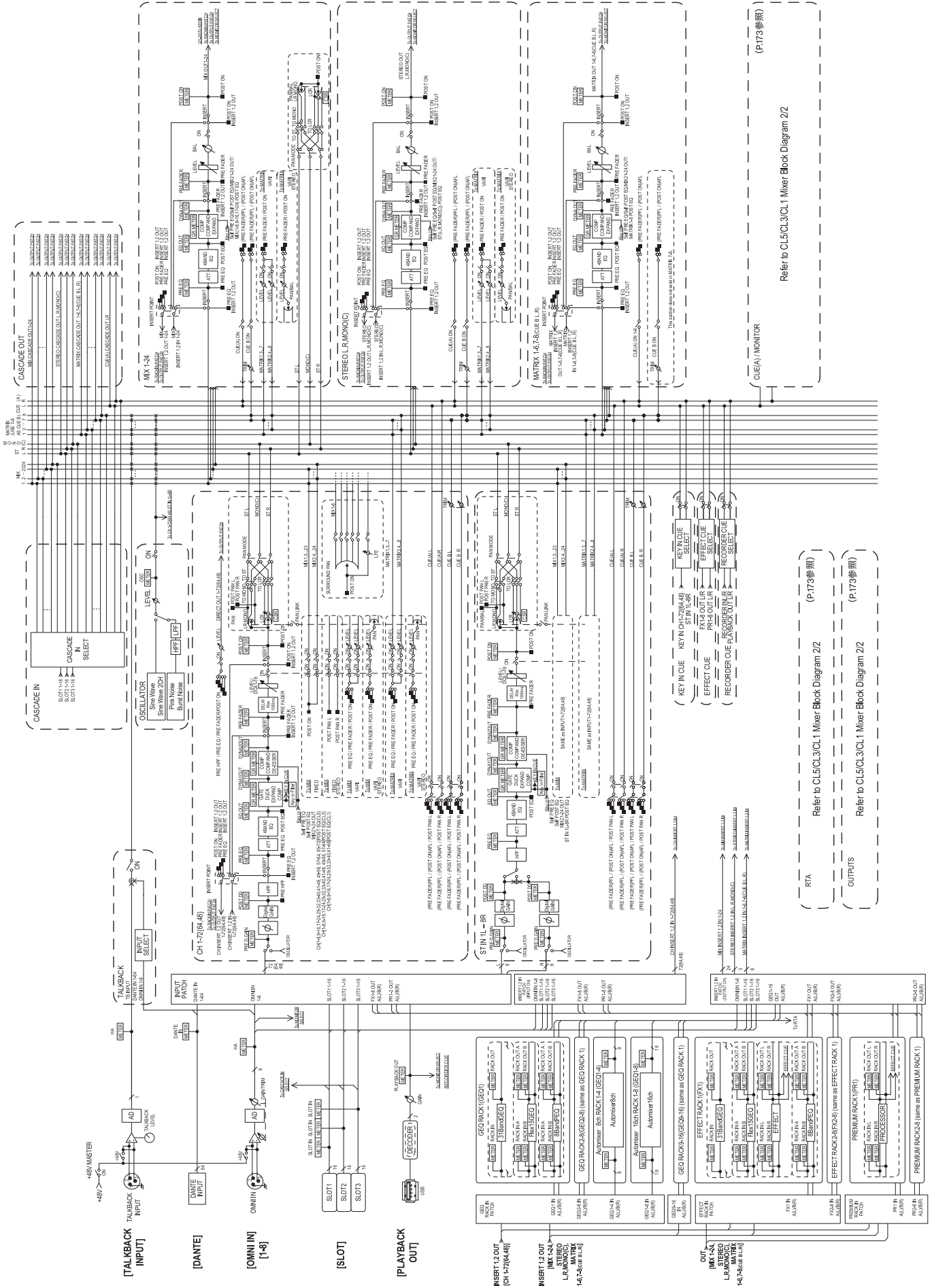

Block Diagram: CL Series 2/2

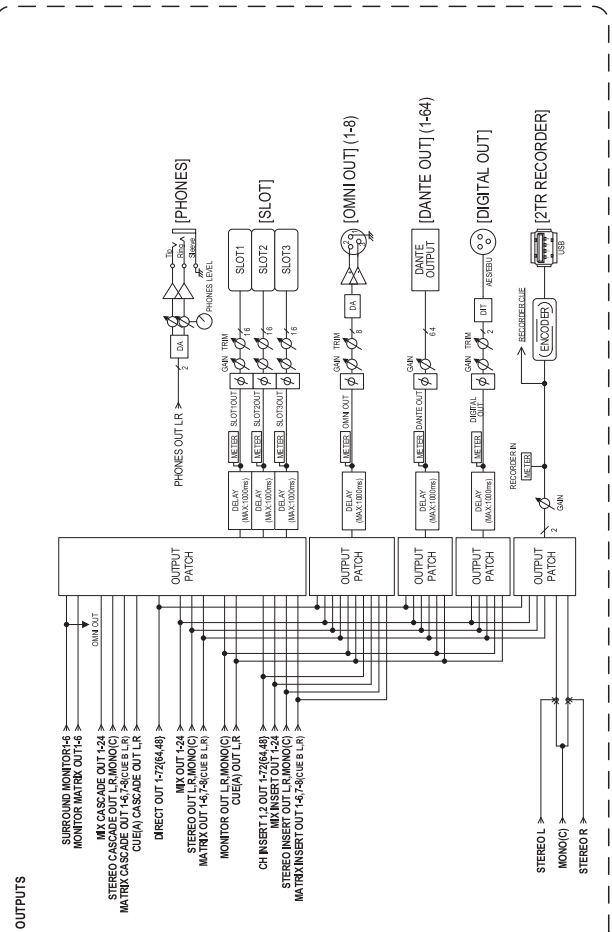
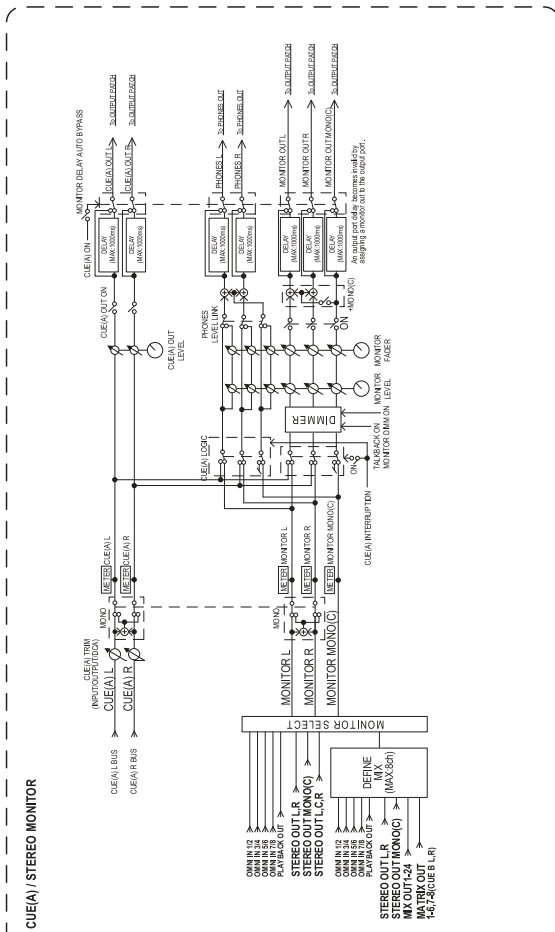
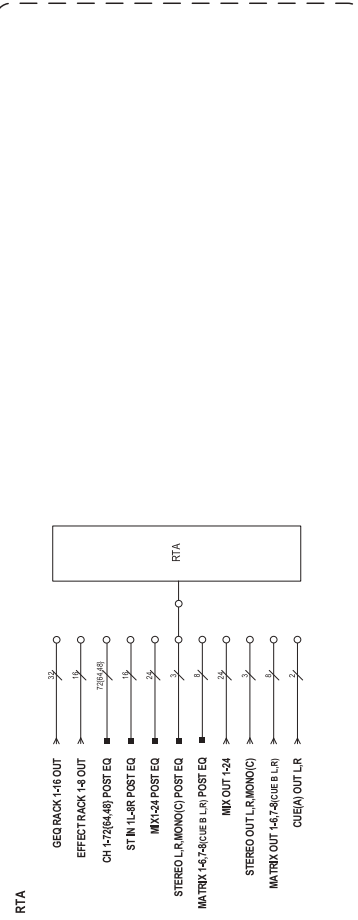
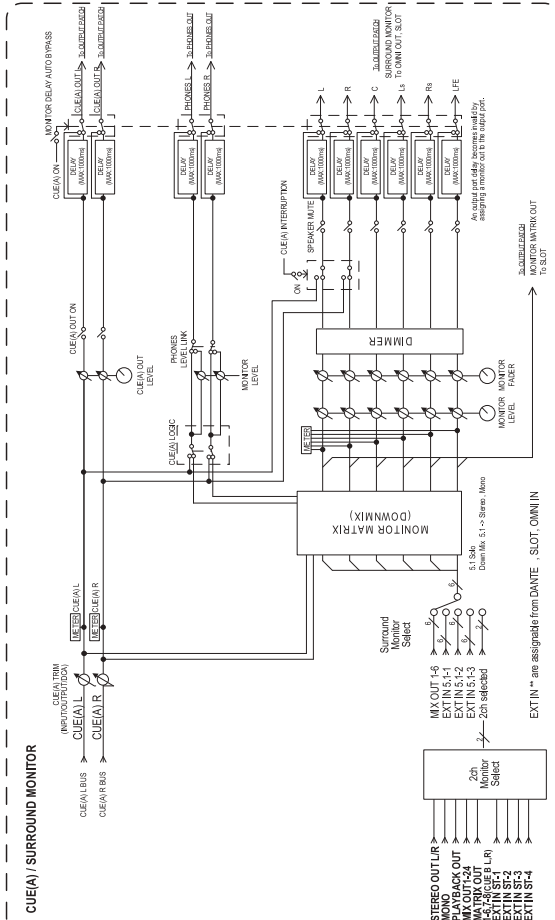

Block Diagram: QL Series 1/2

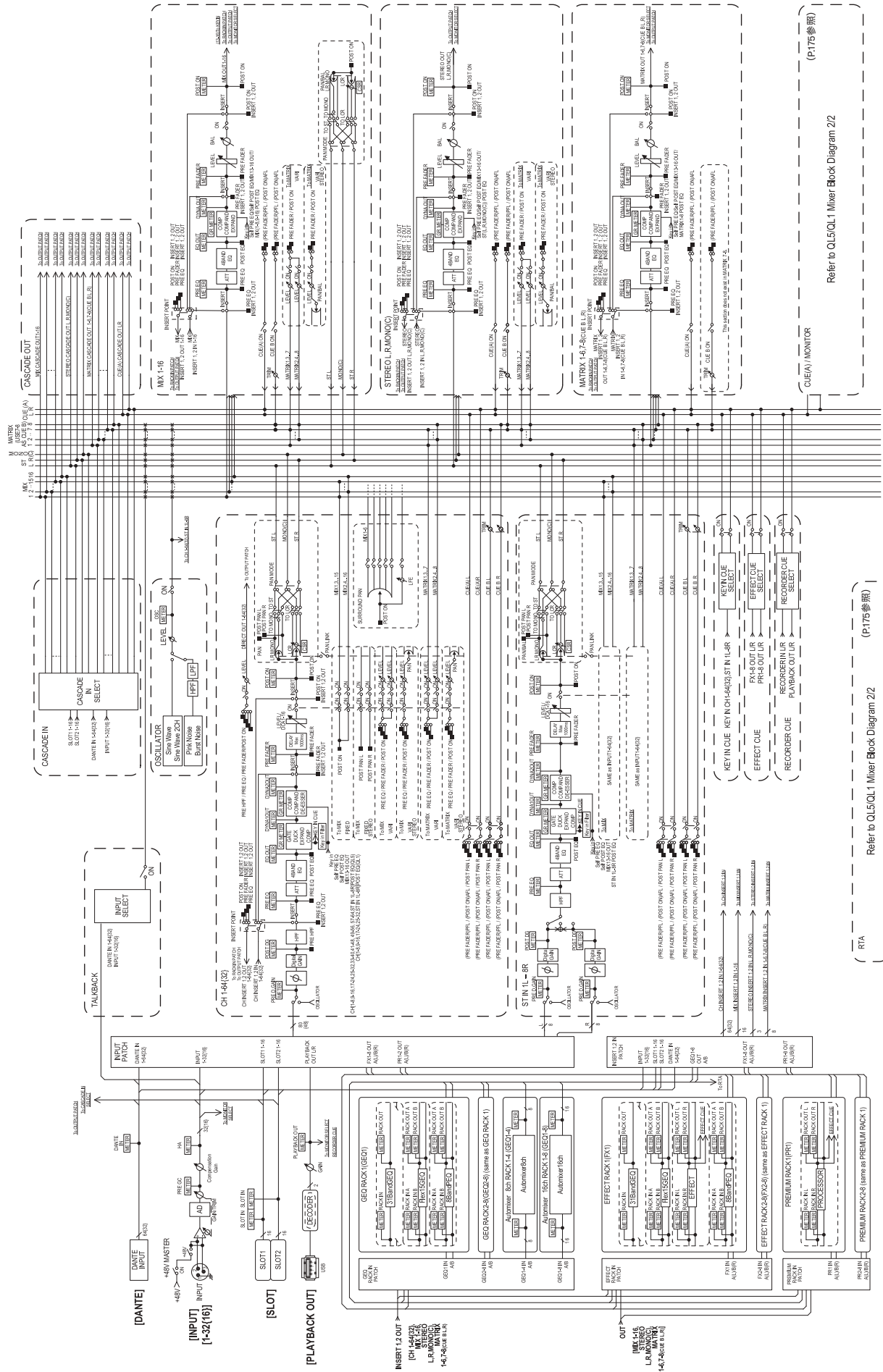

(P.175参照)

Refer to QL5/QL1 Mixer Block Diagram 22

CUE(N) / MONITOR

(P.175参照)

Refer to QL5/QL1 Mixer Block Diagram 22

RTA

(P.175参照)

Refer to QL5/QL1 Mixer Block Diagram 22

OUTPUTS

(P.175参照)

Block Diagram: QL Series 2/2

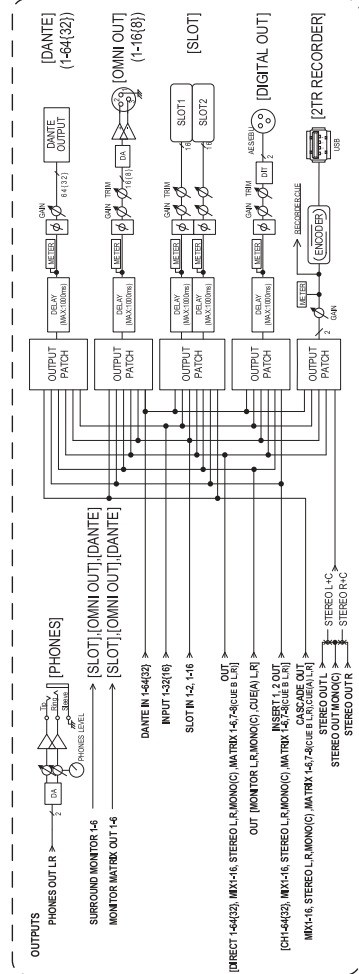
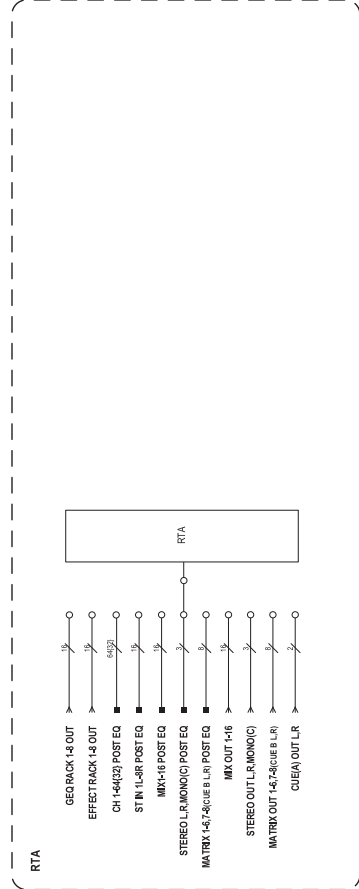
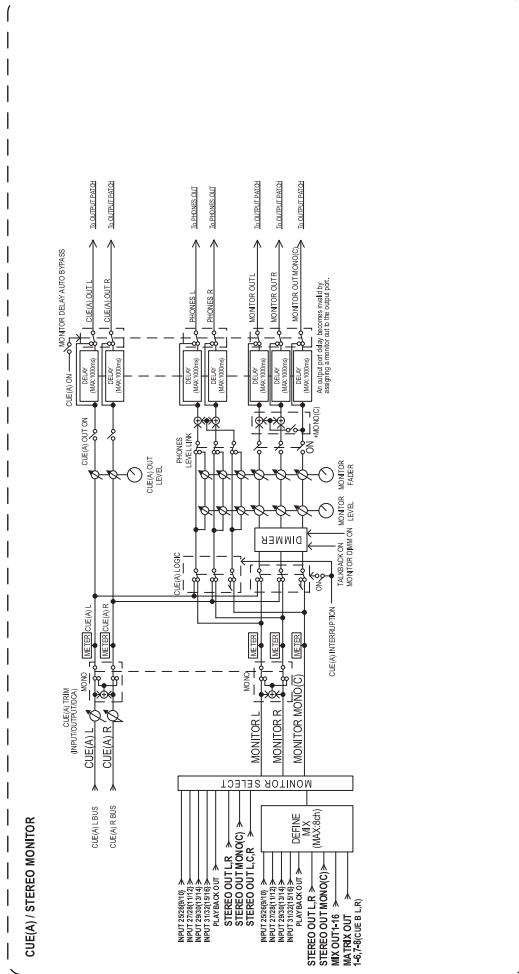
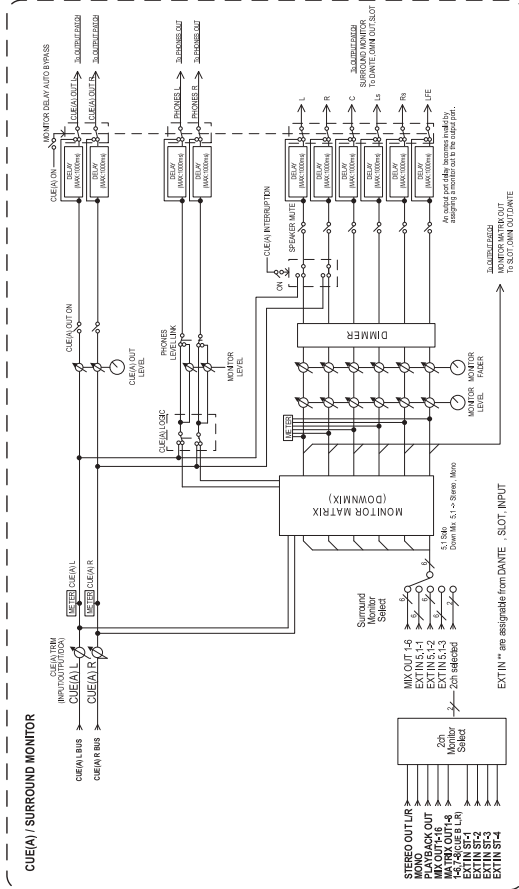

Block Diagram: DM3 Series

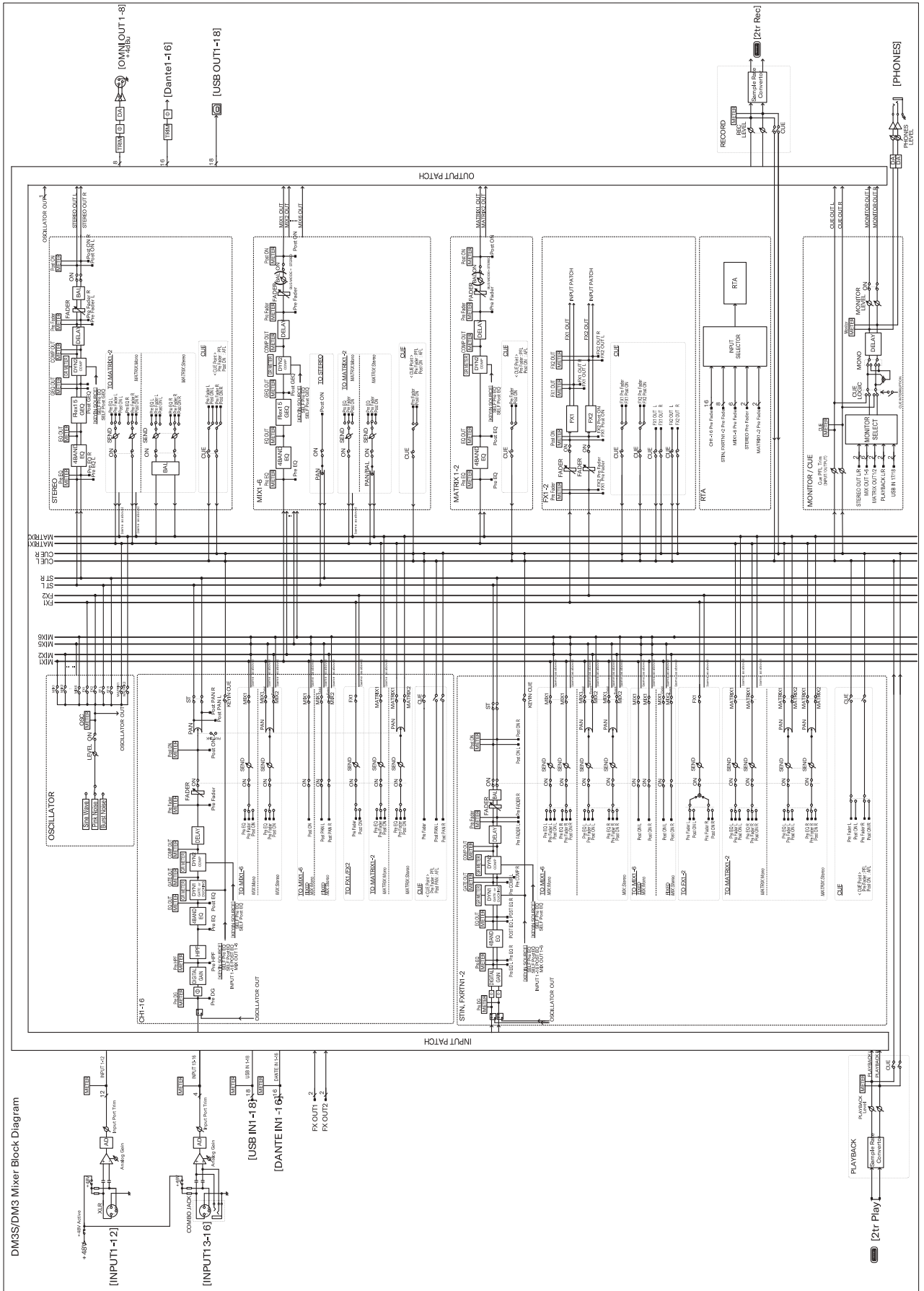

Block Diagram: TF Series

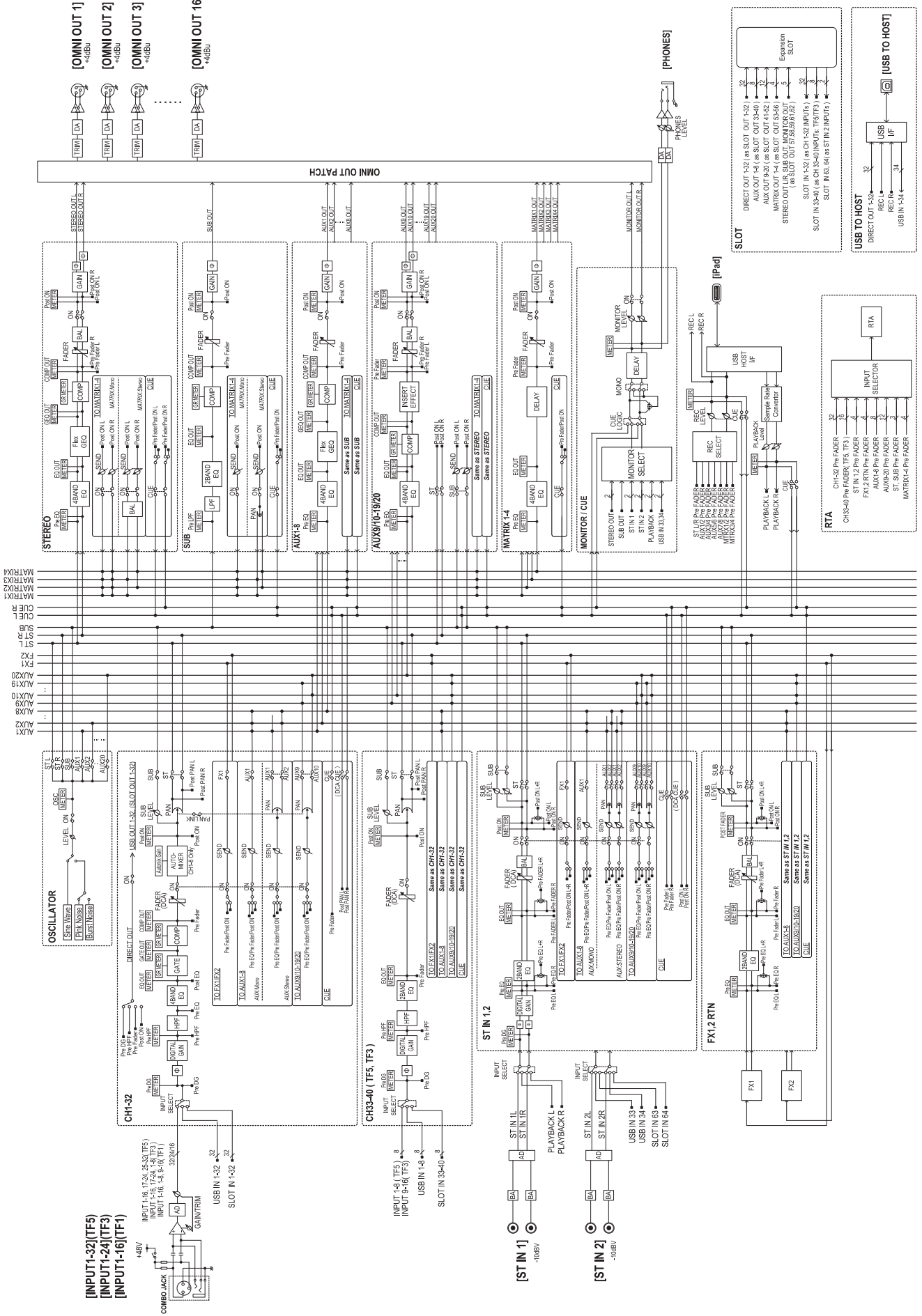

Block Diagram: TF-RACK

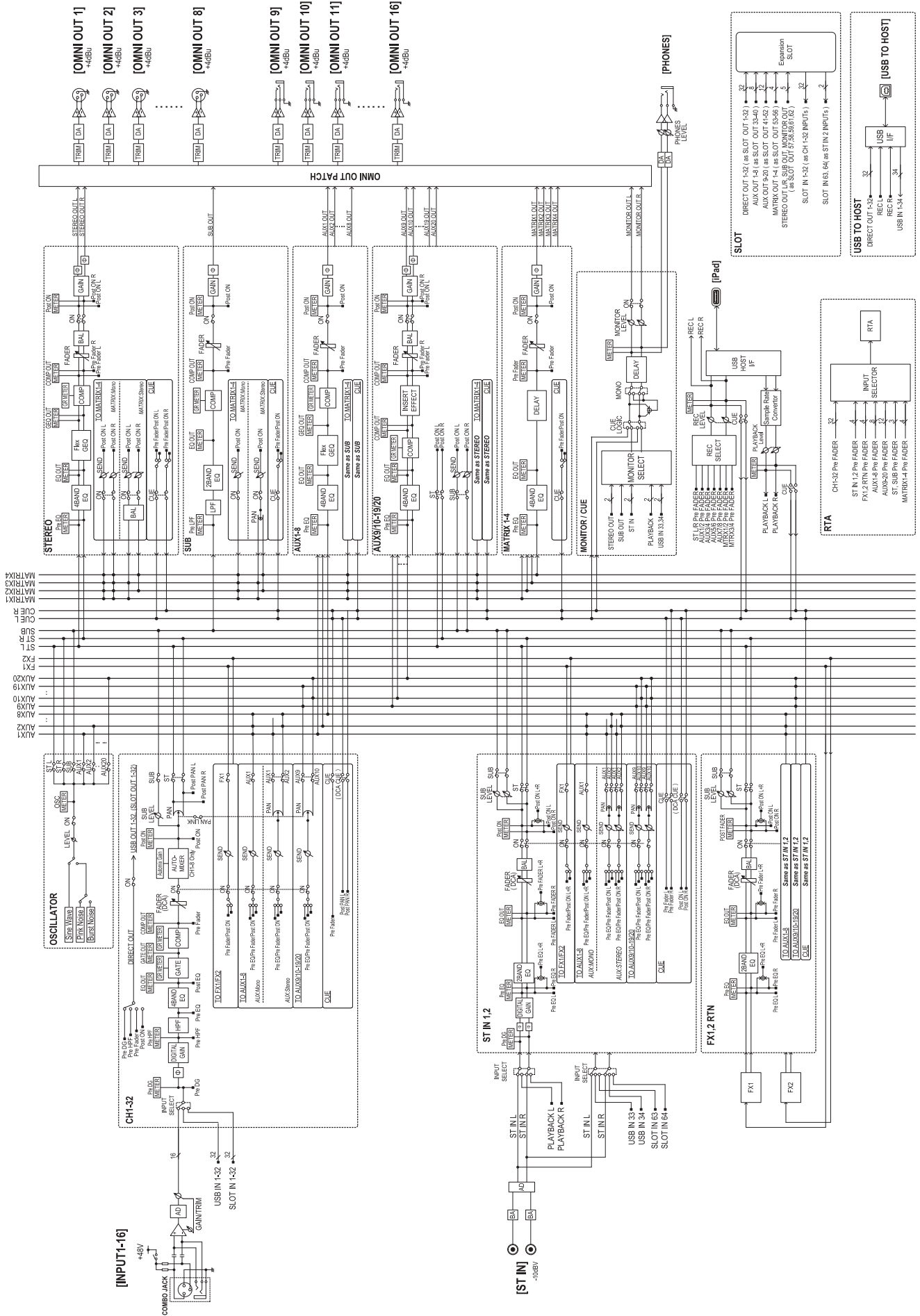

Block Diagram: RUio16-D

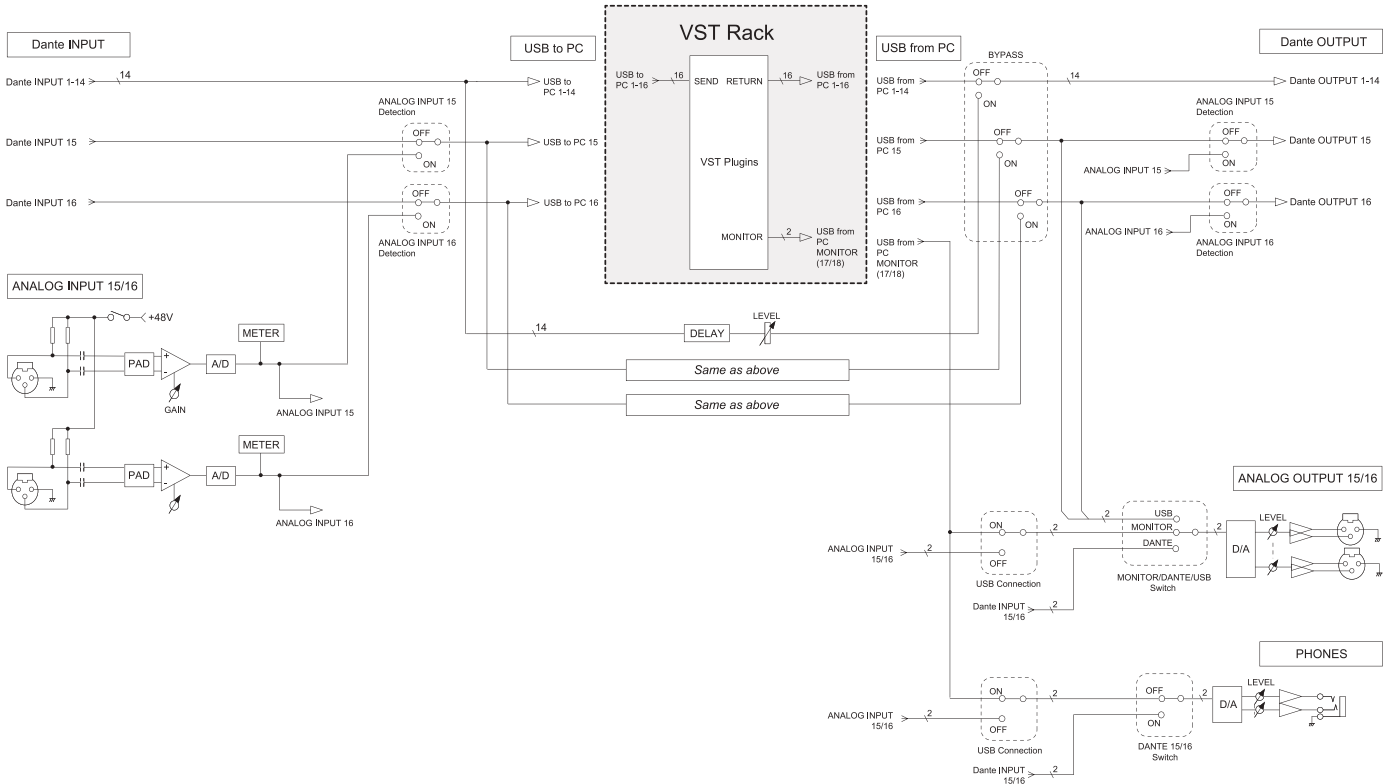

Block Diagram: MGP32X, MGP24X

※ファンタム電源はXLR入力端子にのみDC+48Vが供給されます。

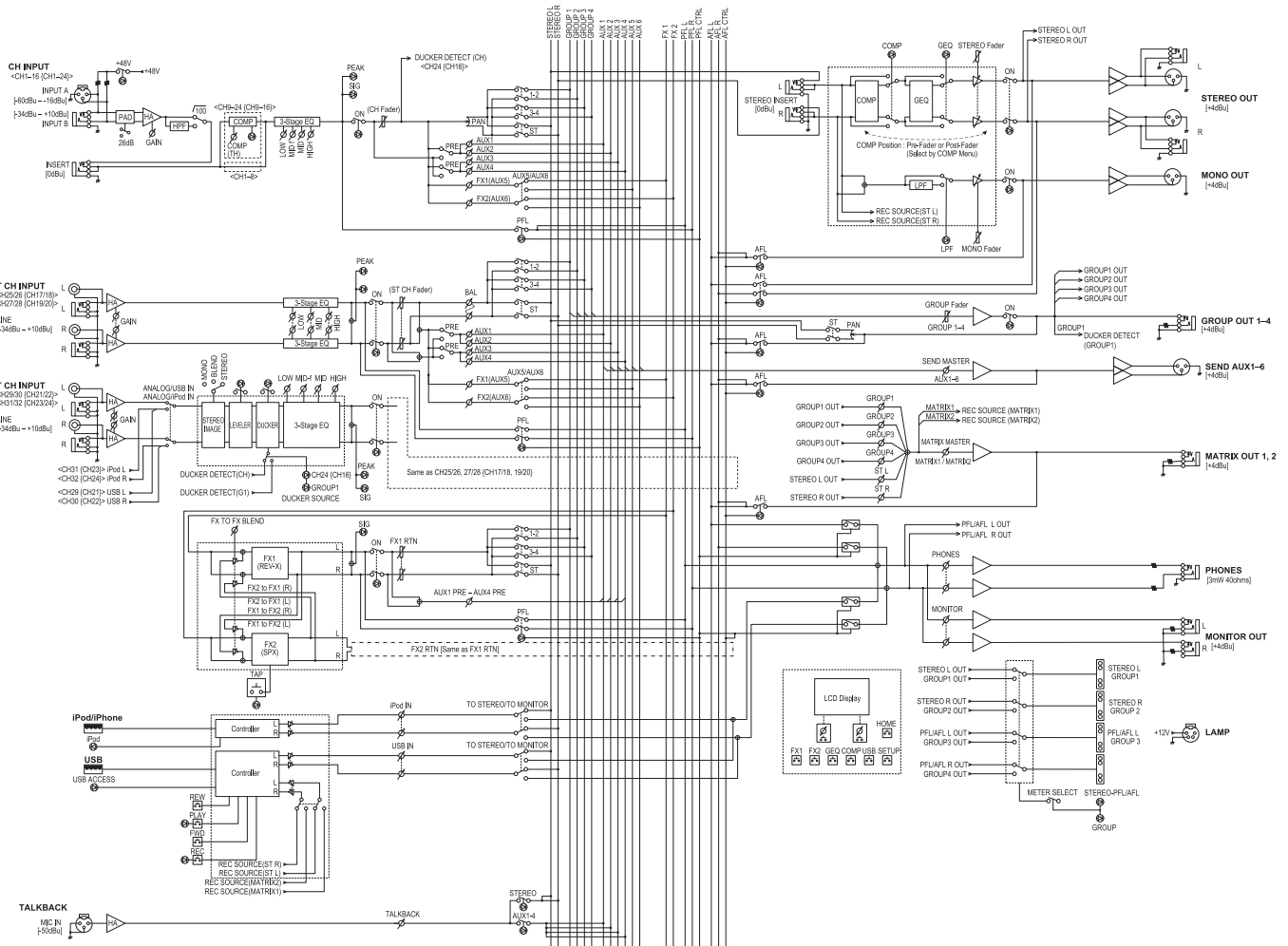

Block Diagram: MG20XU, MG20 ※ファンタム電源はXLR入力端子にのみDC+48Vが供給されます。

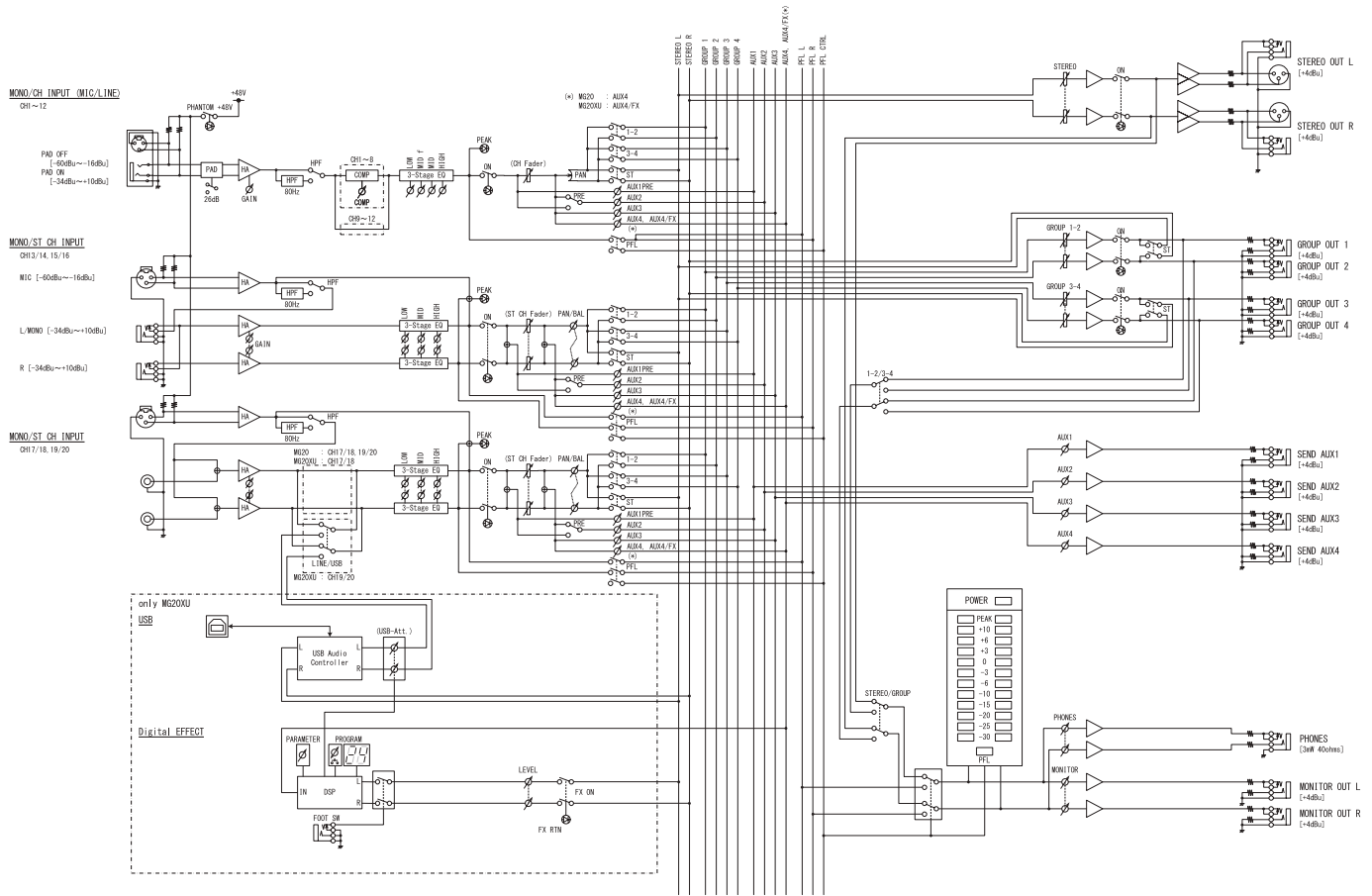

Block Diagram: MG16XU, MG16X, MG16 ※ファンタム電源はXLR入力端子にのみDC+48Vが供給されます。

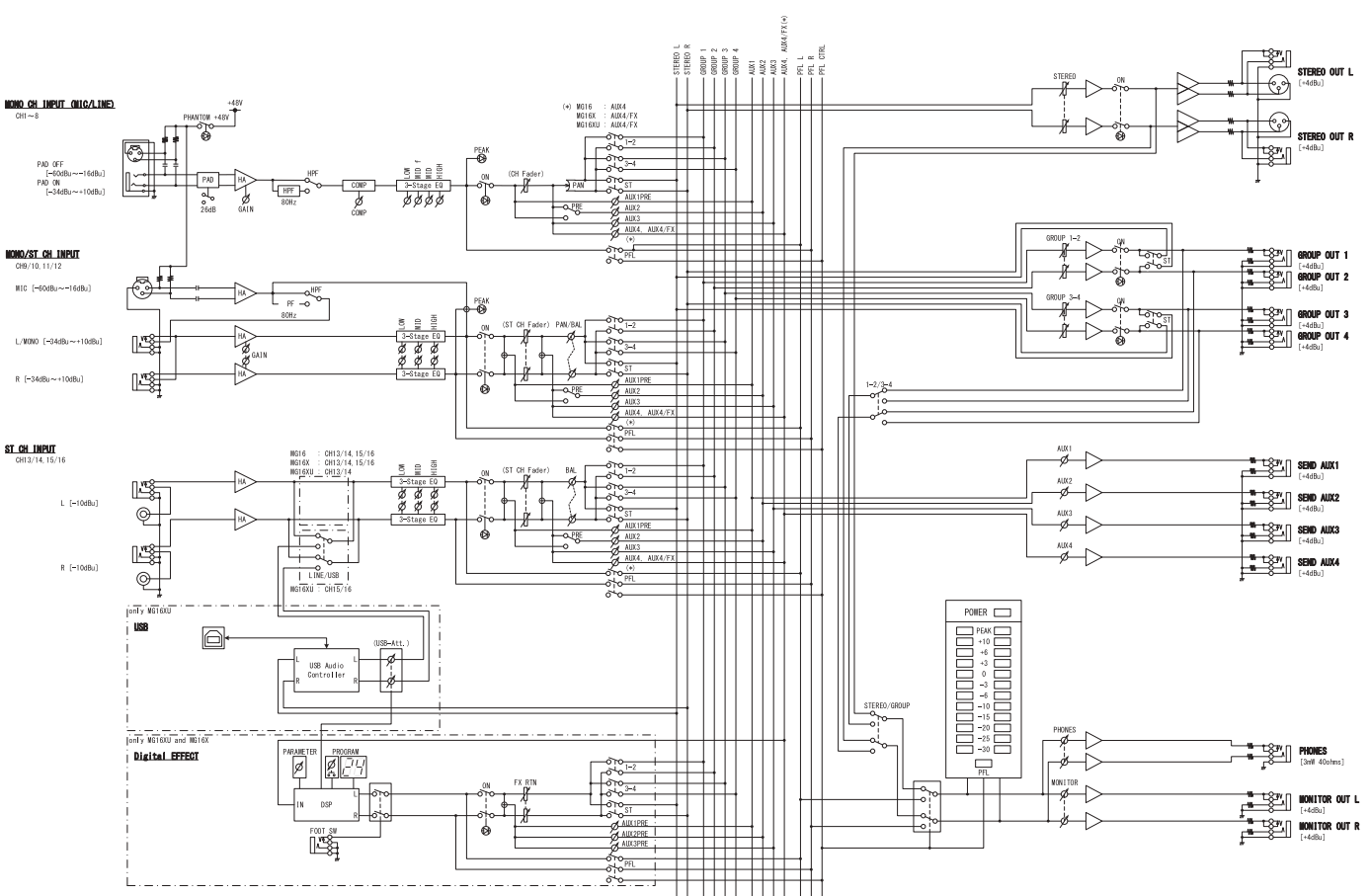

Block Diagram: MG12XU, MG12X, MG12 ※ファンタム電源はXLR入力端子にのみDC+48Vが供給されます。

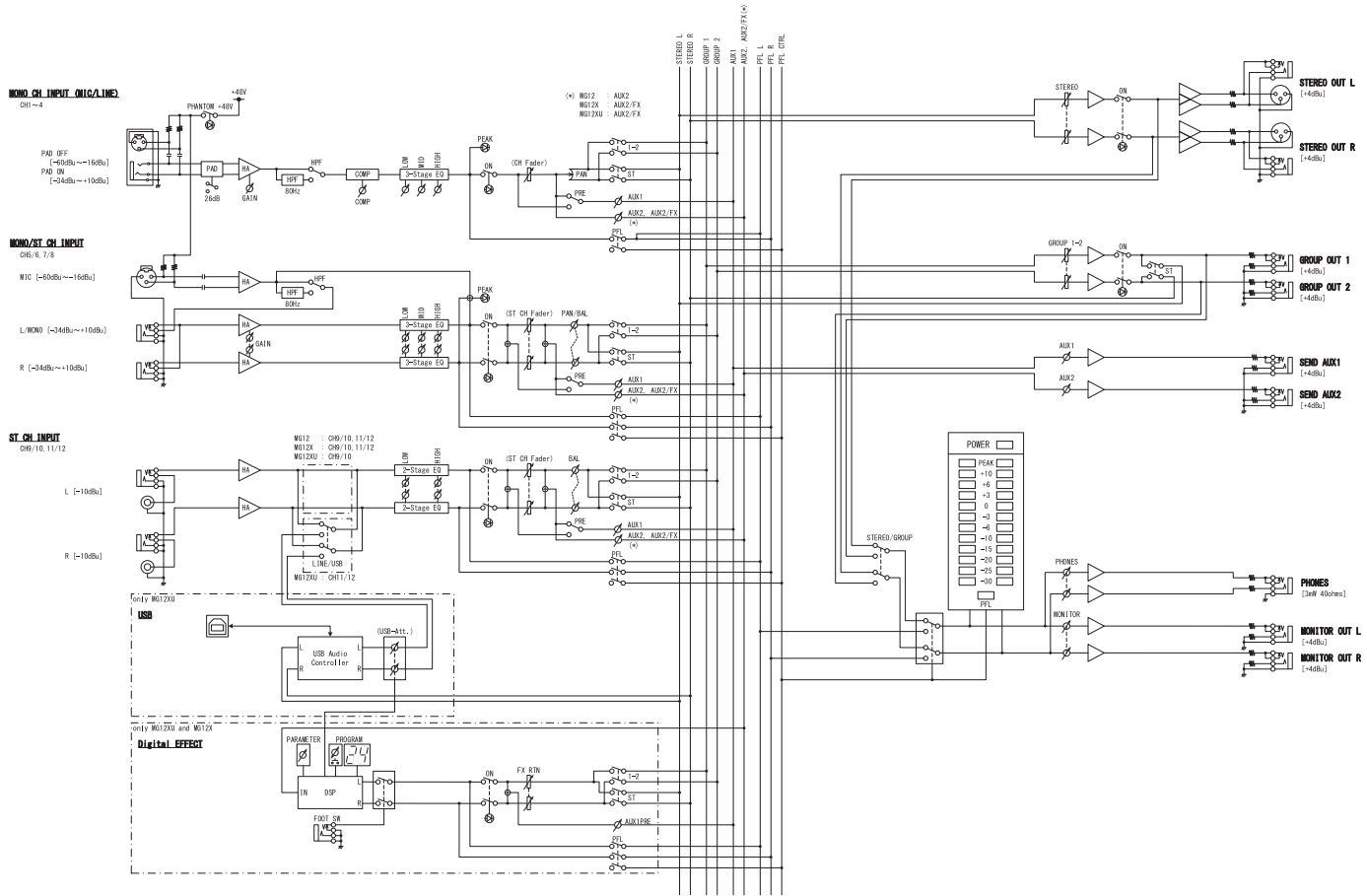

Block Diagram: MG12XUK ※ファンタム電源はXLR入力端子にのみDC+48Vが供給されます。

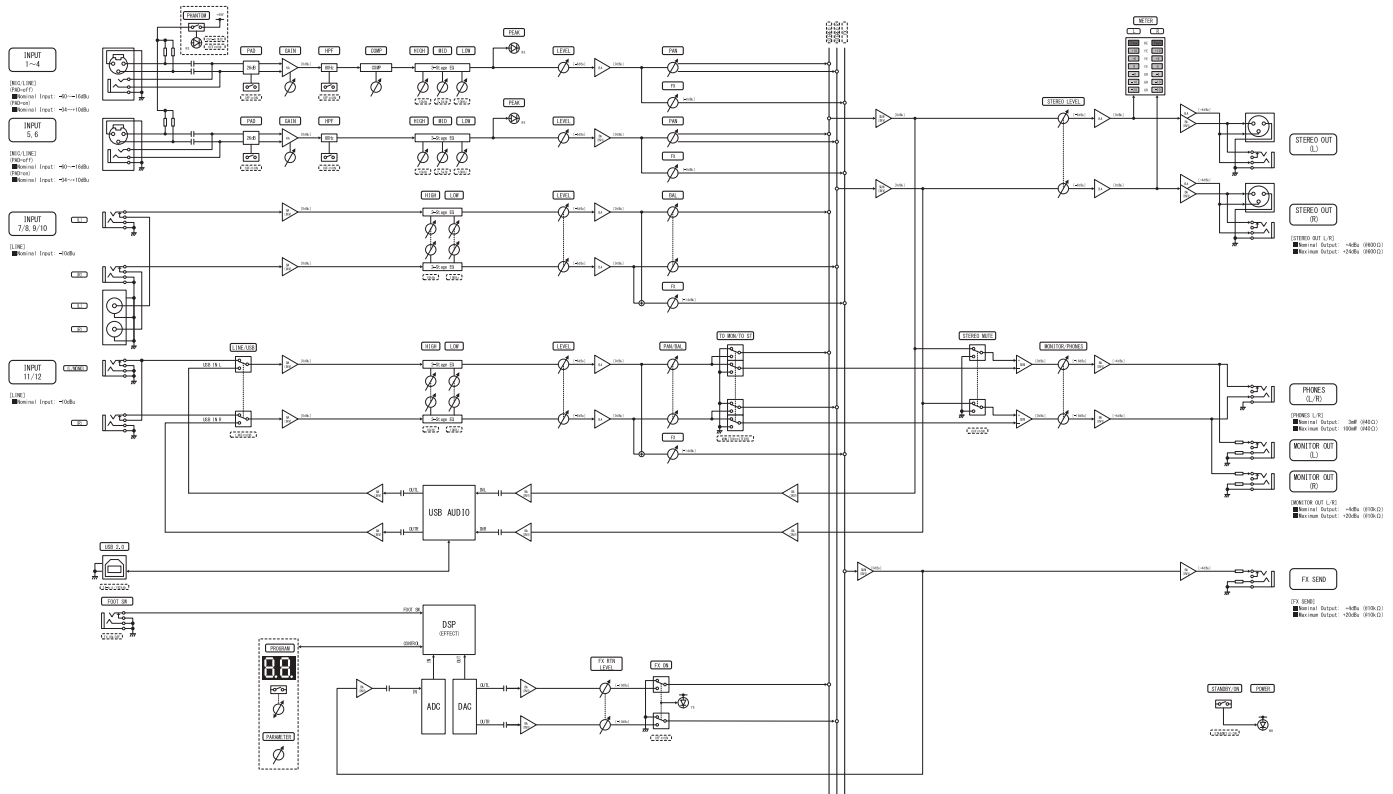

Block Diagram: MG10XU, MG10X, MG10 ※ファンタム電源はXLR入力端子にのみDC+48Vが供給されます。

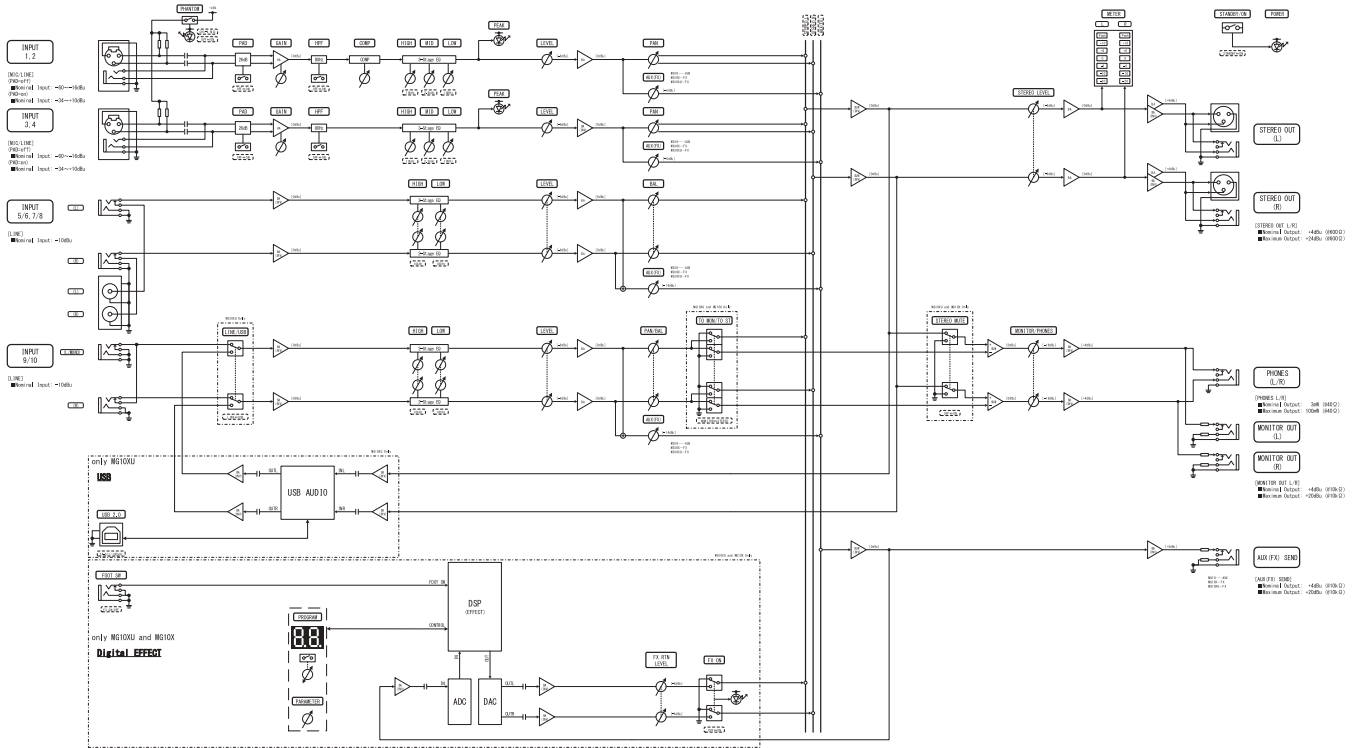

Block Diagram: MG10XUF ※ファンタム電源はXLR入力端子にのみDC+48Vが供給されます。

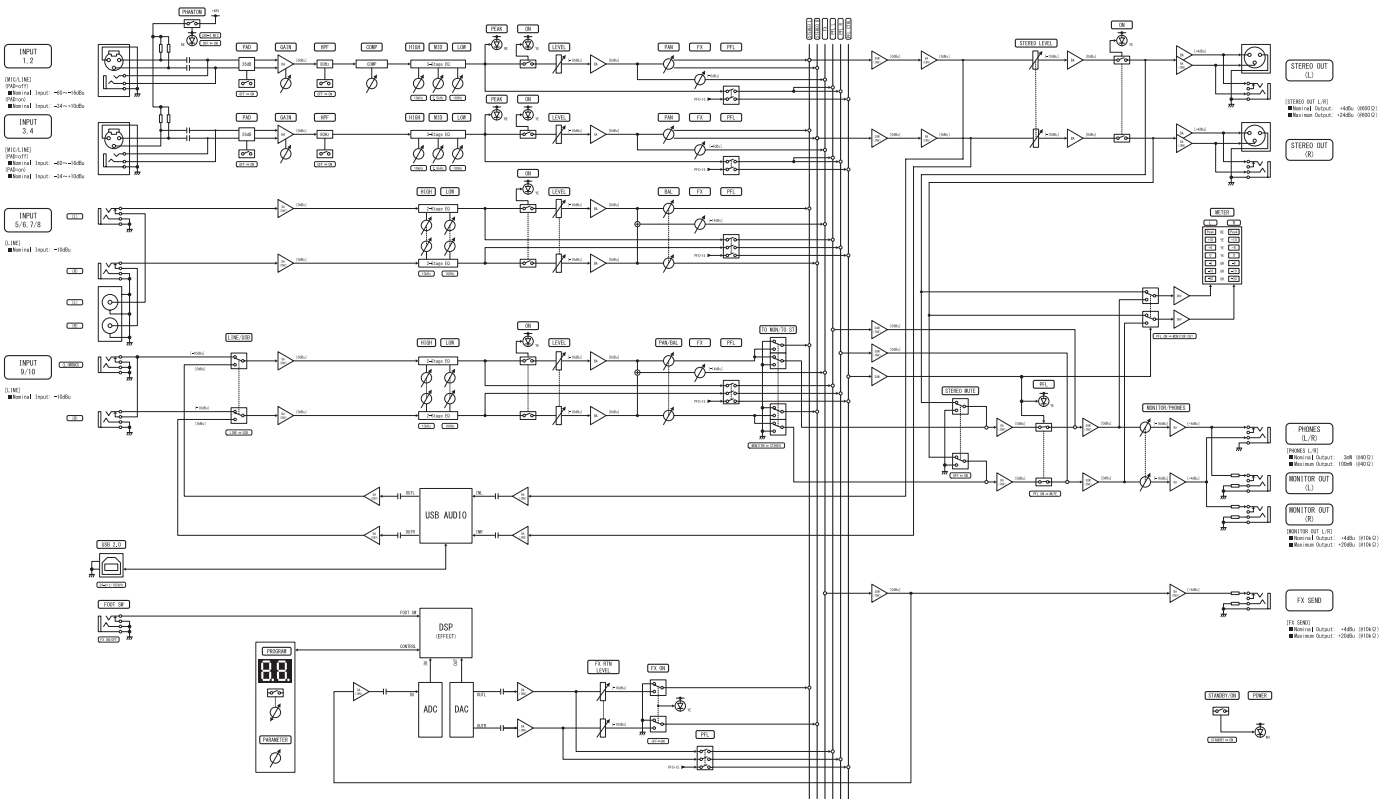

Block Diagram: MG06X, MG06 ※ファンタム電源はXLR入力端子にのみDC+48Vが供給されます。

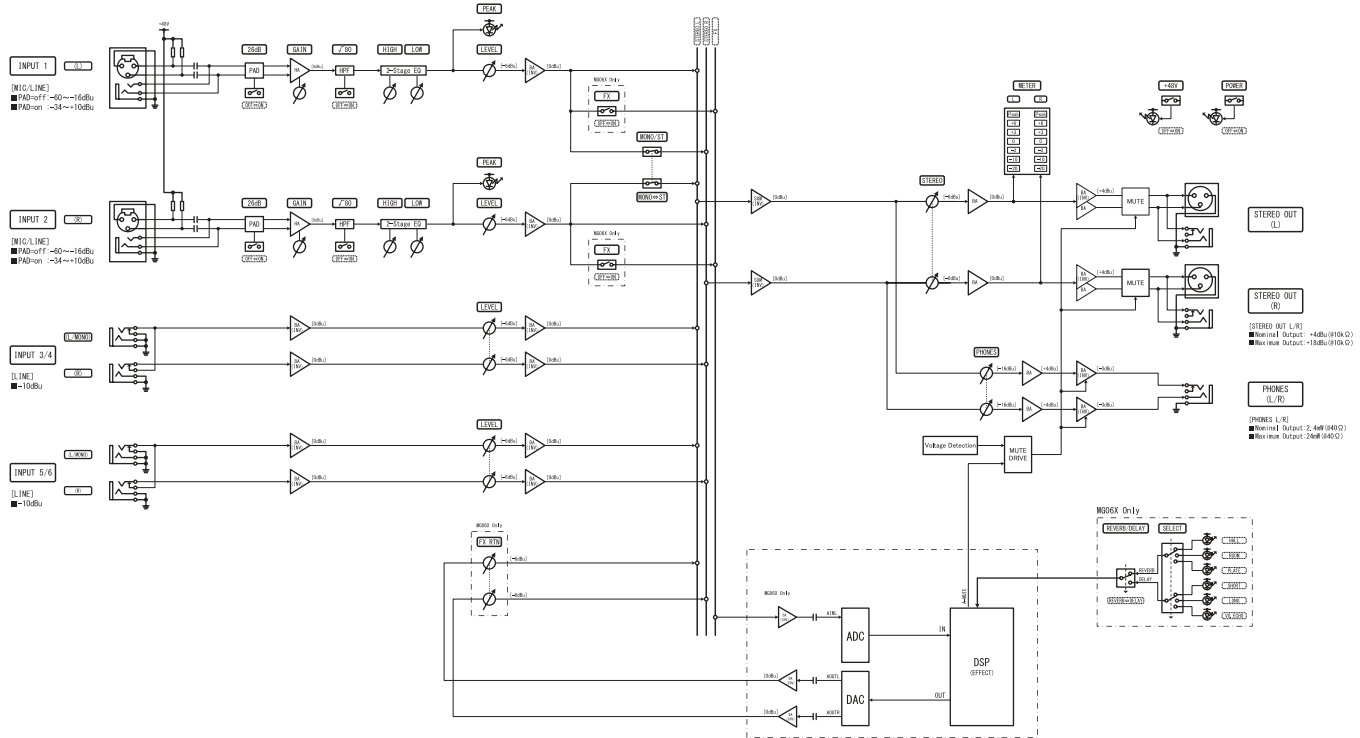

Block Diagram: EMX7 ※ファンタム電源はXLR入力端子にのみDC+48Vが供給されます。

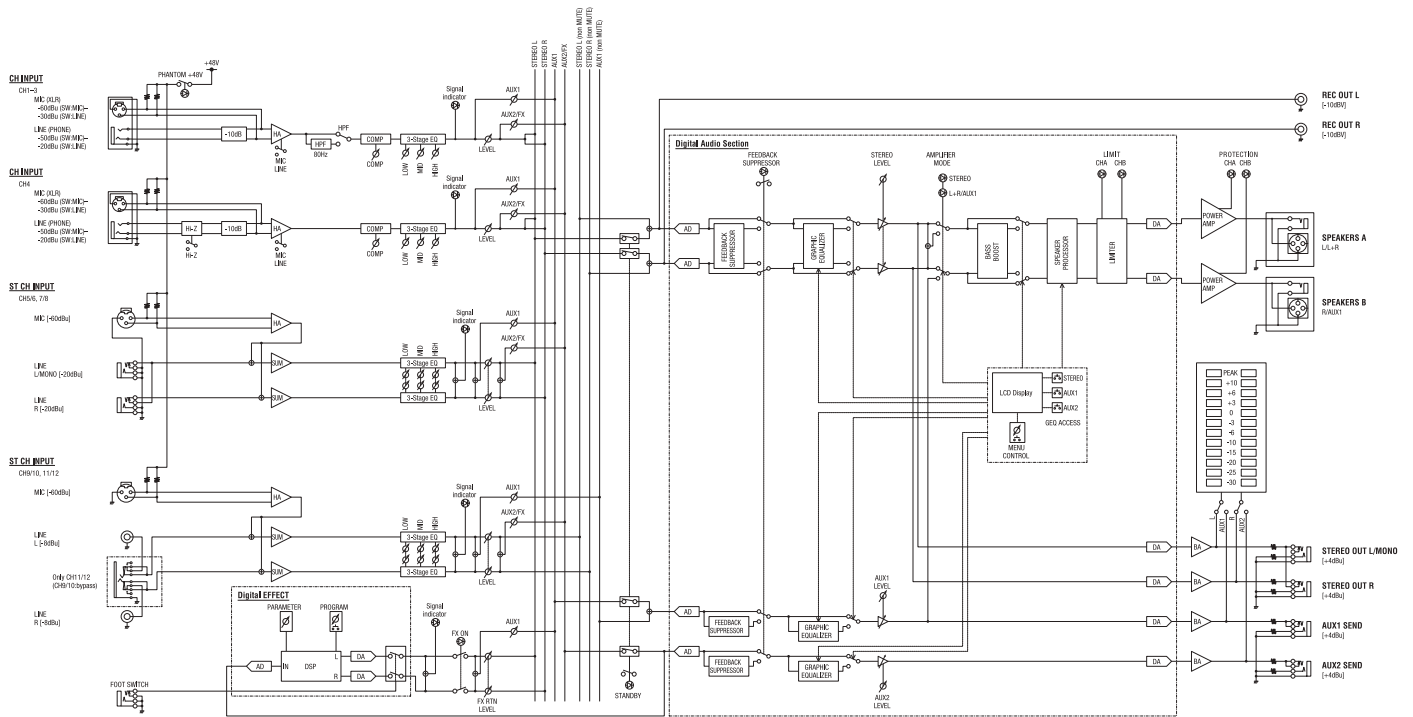

Block Diagram: EMX5

※ファンタム電源はXLR入力端子にのみDC+48Vが供給されます。

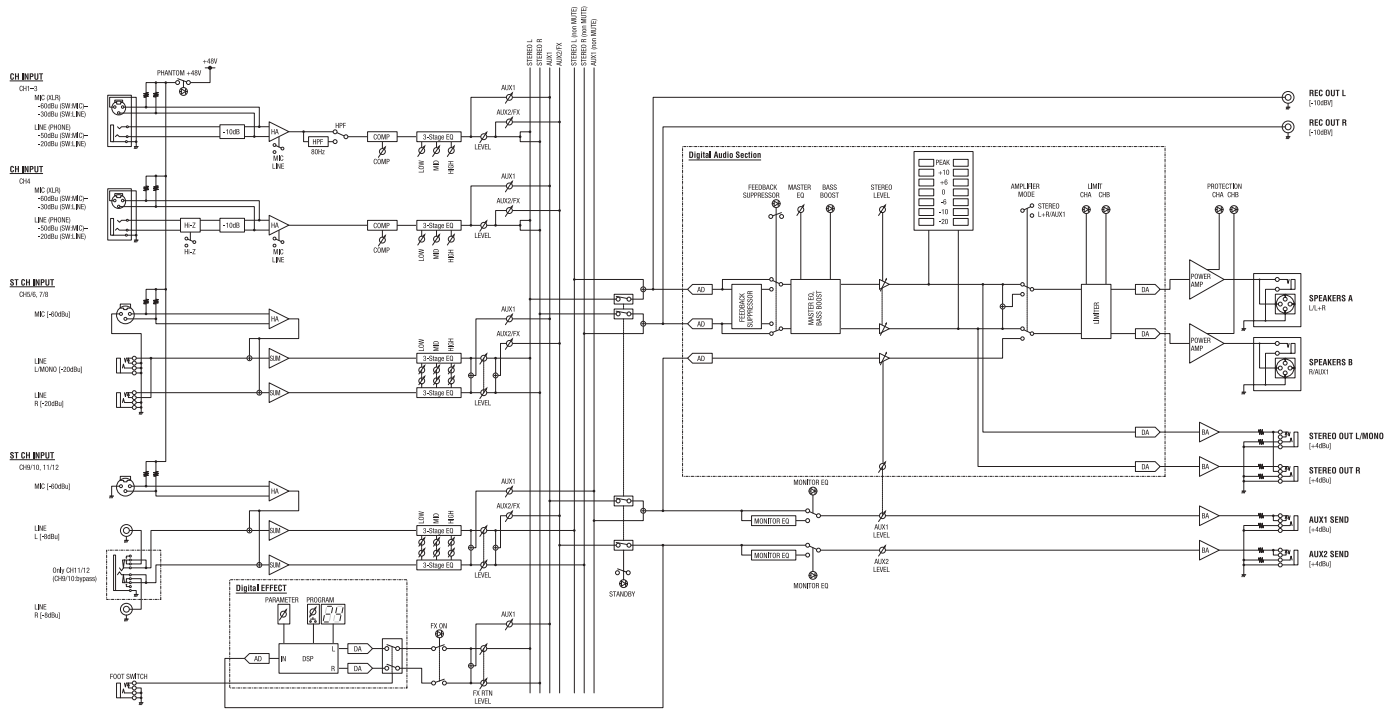

Block Diagram: STAGEPAS 1K mkII

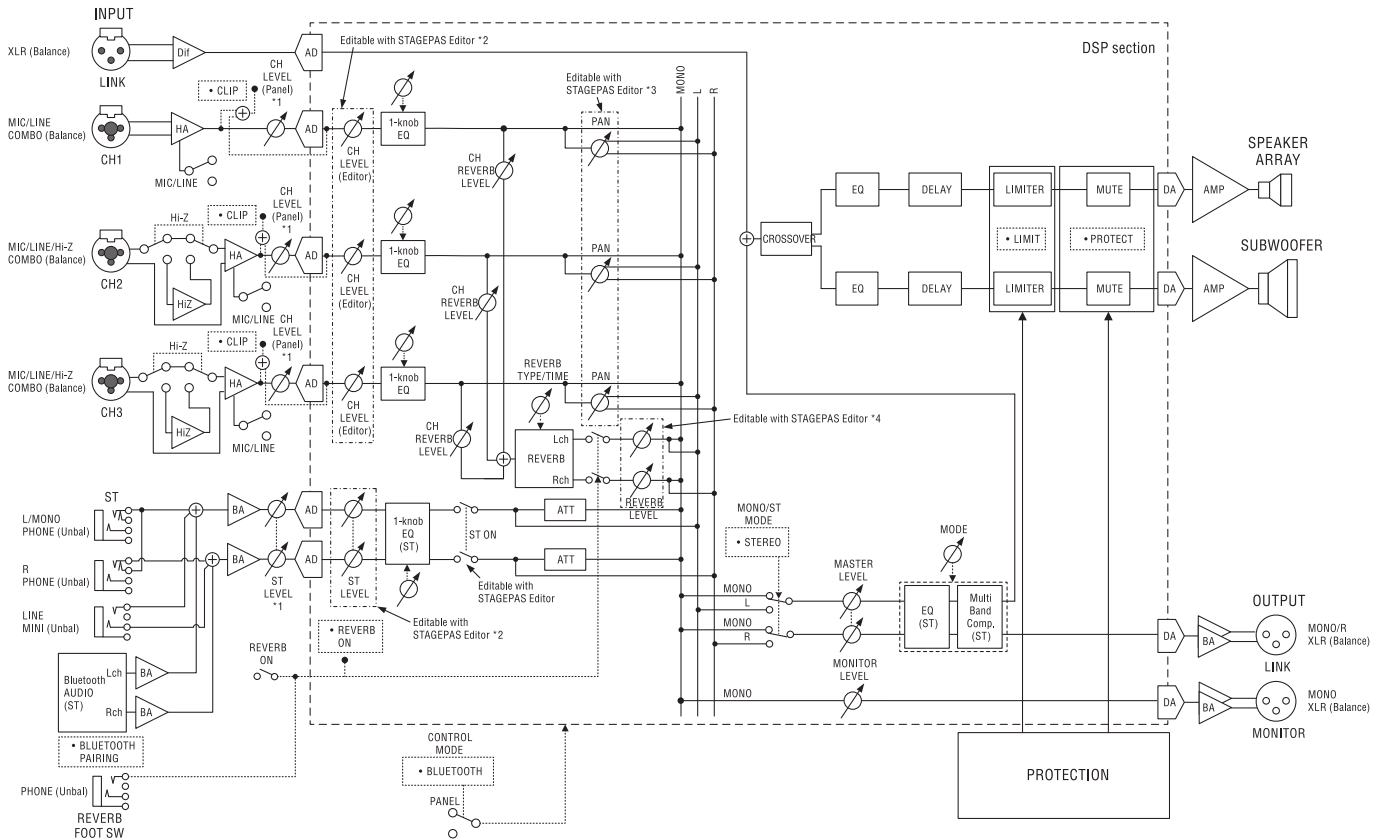

- *1 As for "All CH LEVEL" Volume (CH1-CH3 LEVEL, ST LEVEL), nominal level: Center Q tick position
- *2 At the "Control panel mode", CH LEVEL settings are fixed at 0 dB position.
- *3 At the "Control panel mode", PAN settings are fixed at center position.
- *4 At the "Control panel mode", REVERB LEVEL settings are fixed at -3 dB position.

Block Diagram: STAGEPAS 600BT, STAGEPAS 400BT

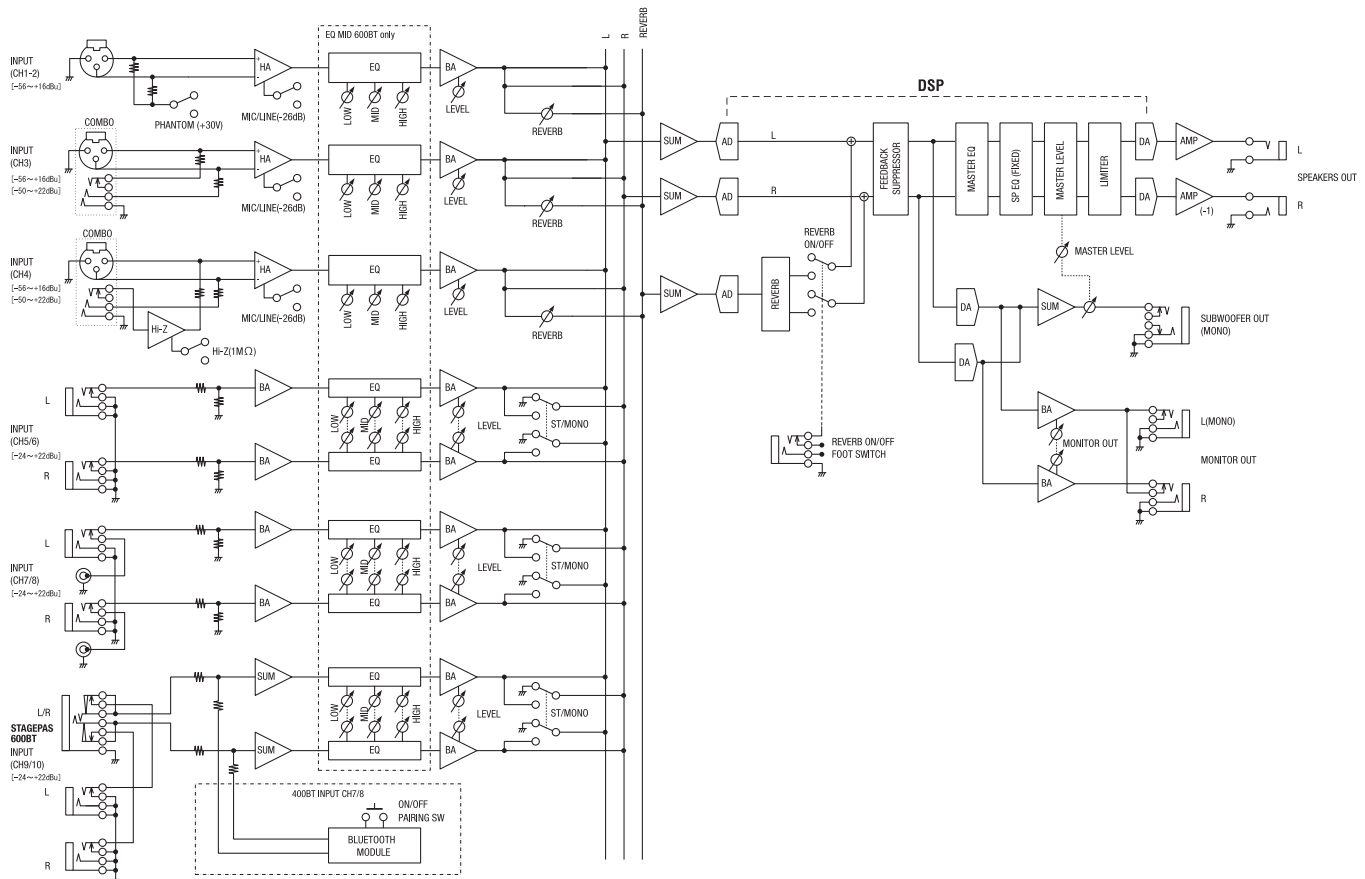

Block Diagram: STAGEPAS 200

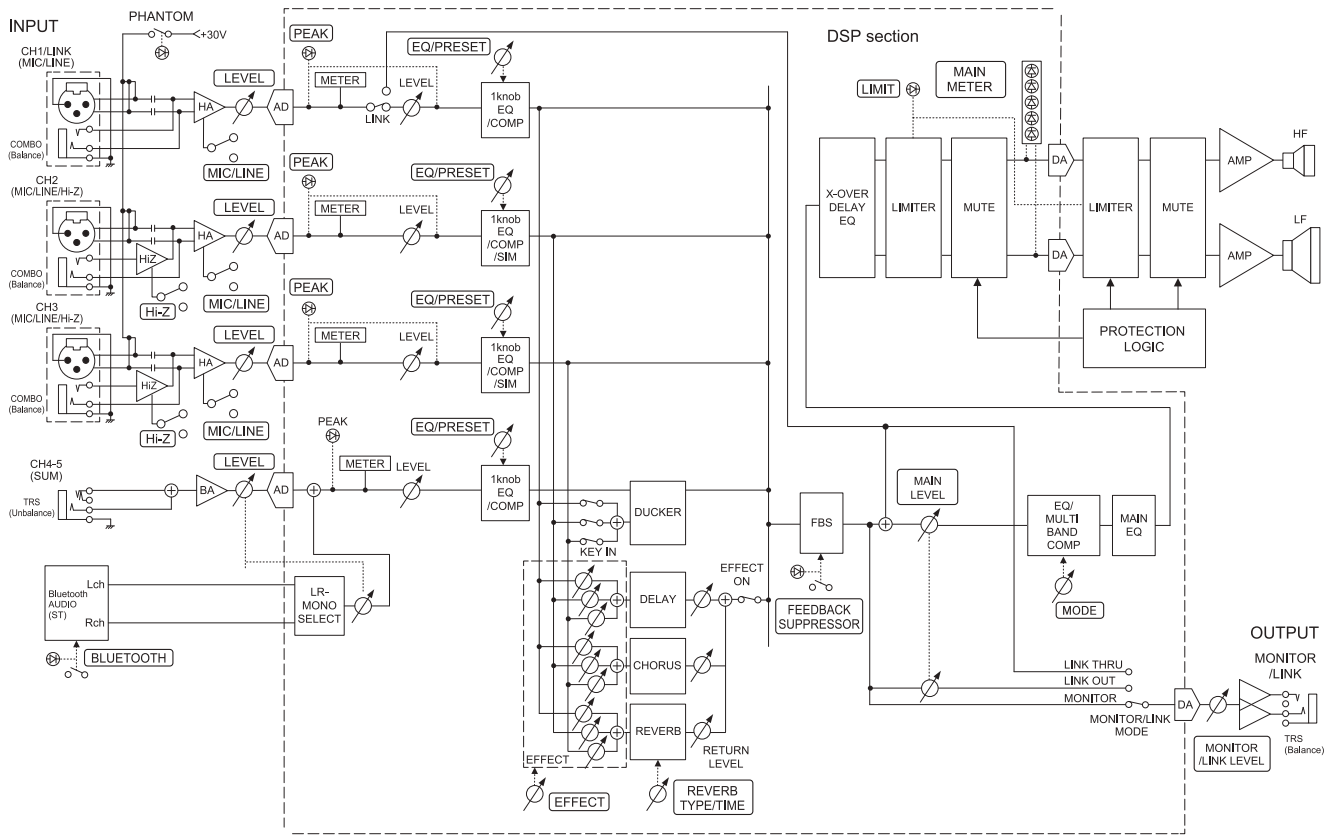

で囲ってある機能は、本体パネルで操作できます、それ以外はアプリのみで監視が可能です。

Block Diagram: STAGEPAS 100

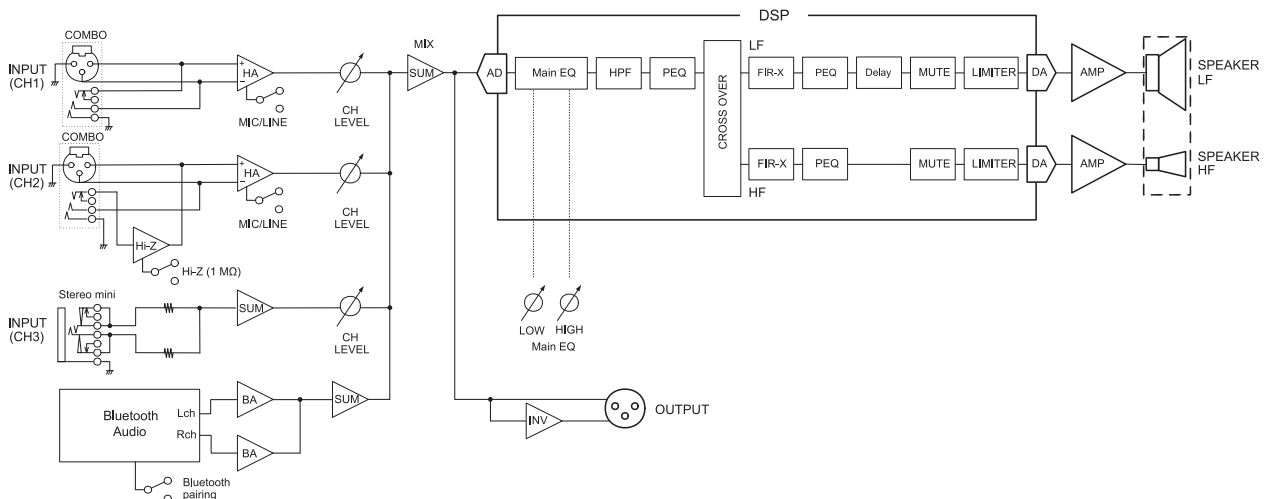

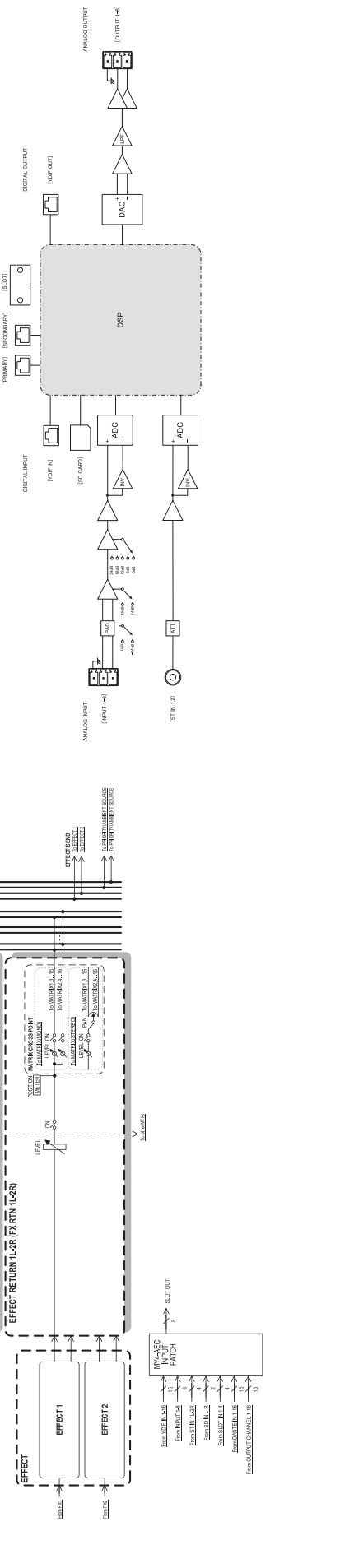
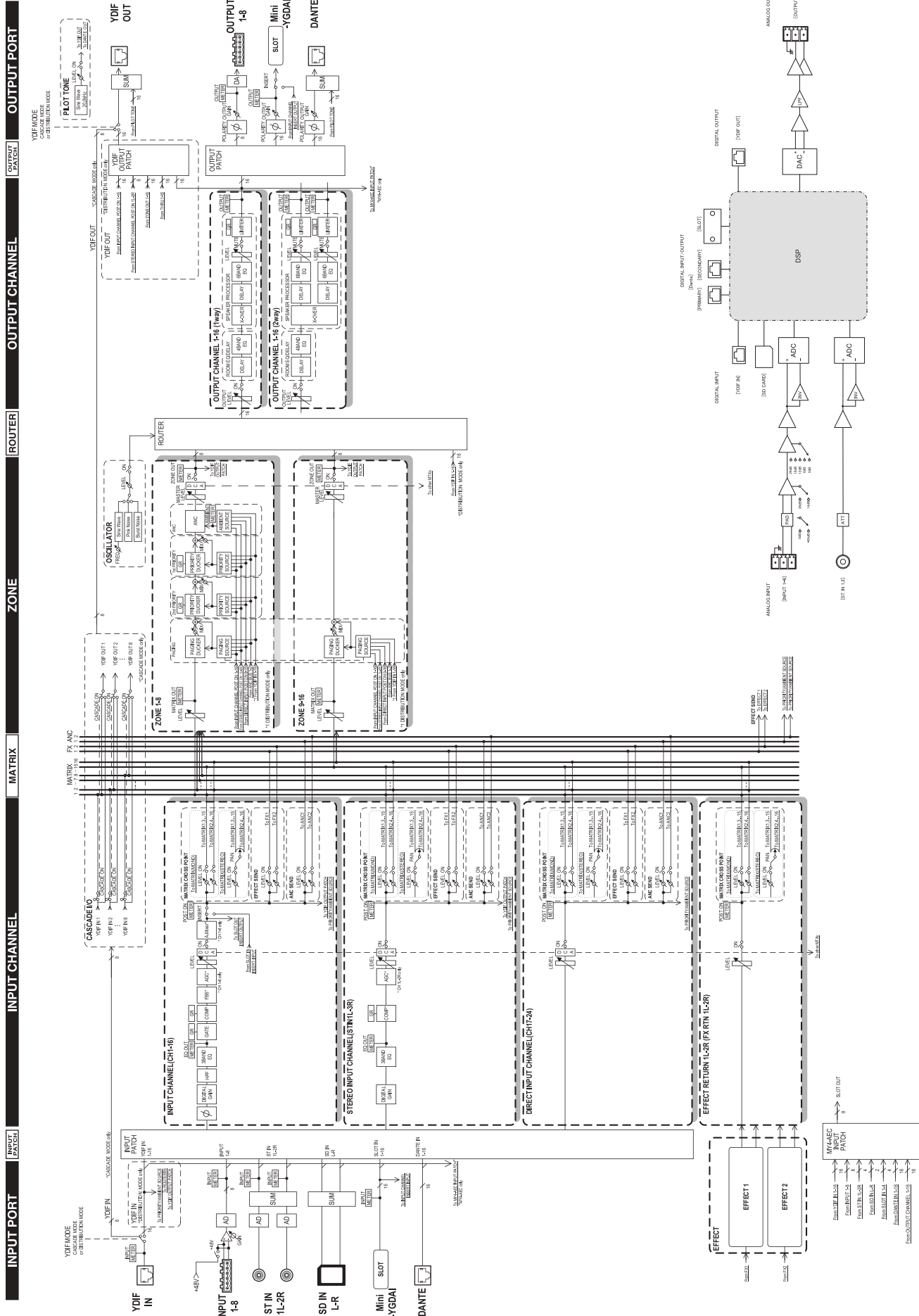

Block Diagram: MTX3

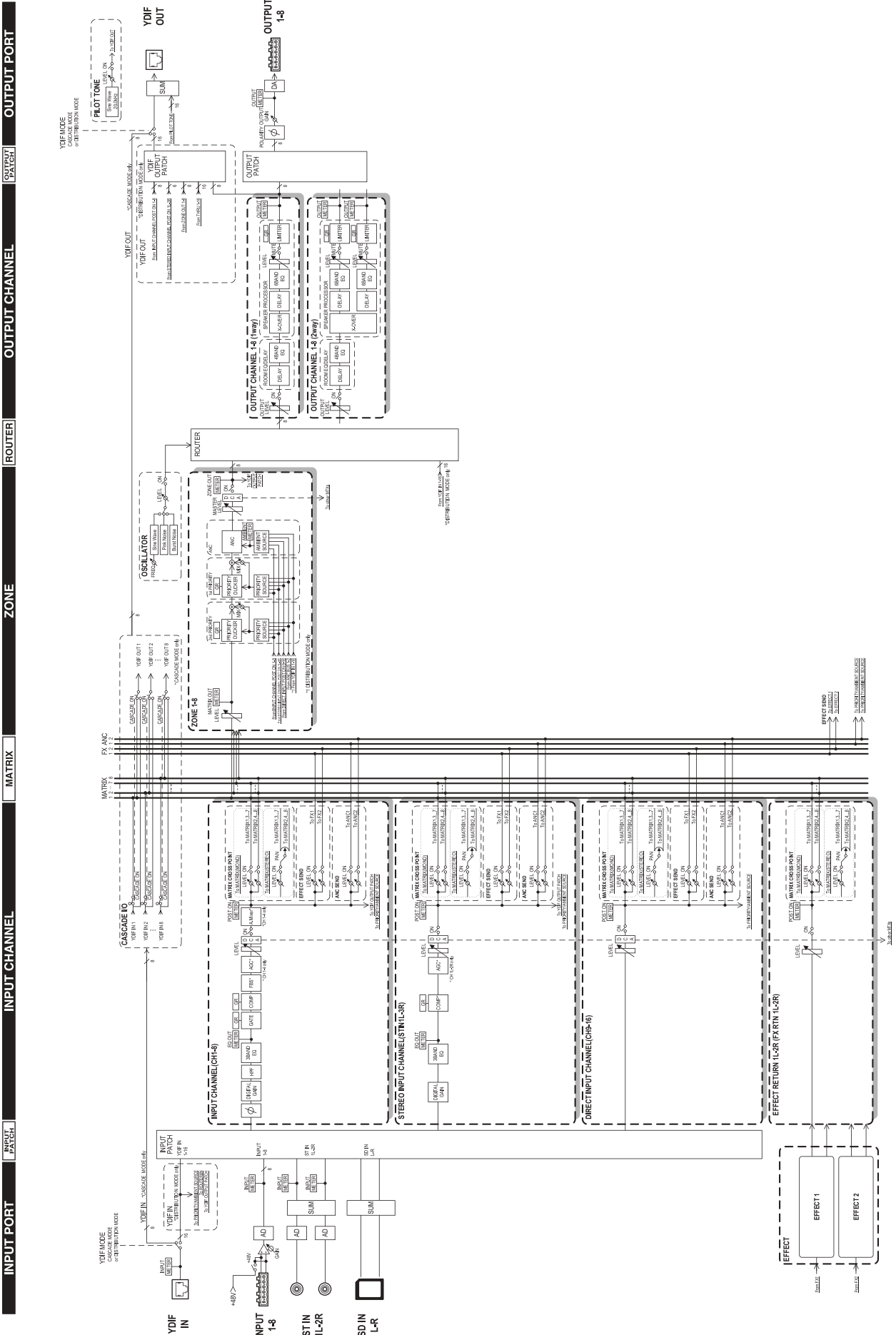

Block Diagram: PC-D/DI Series

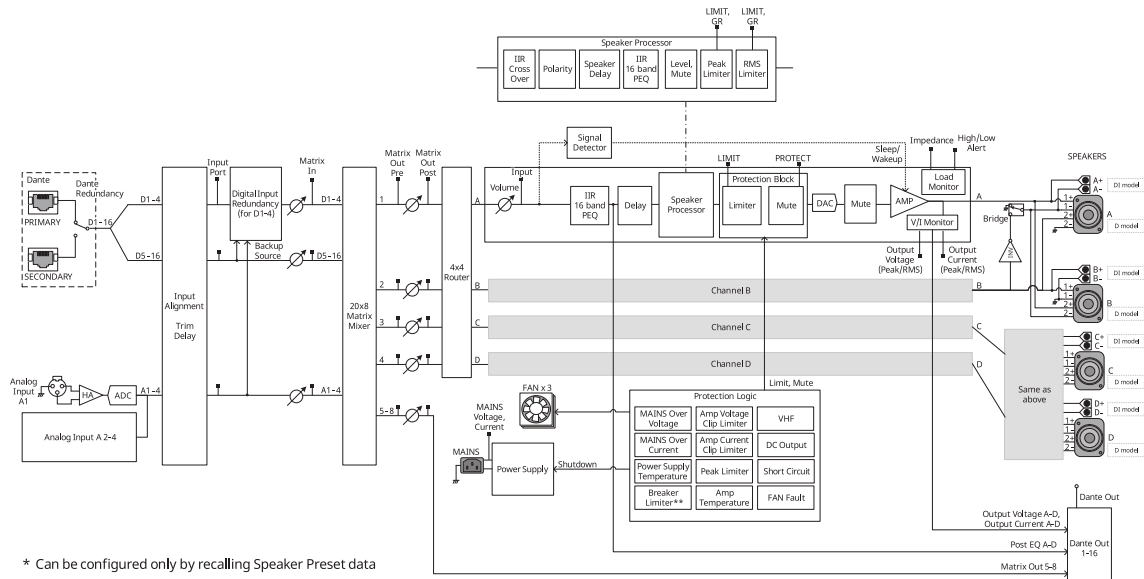

Block Diagram: PX Series

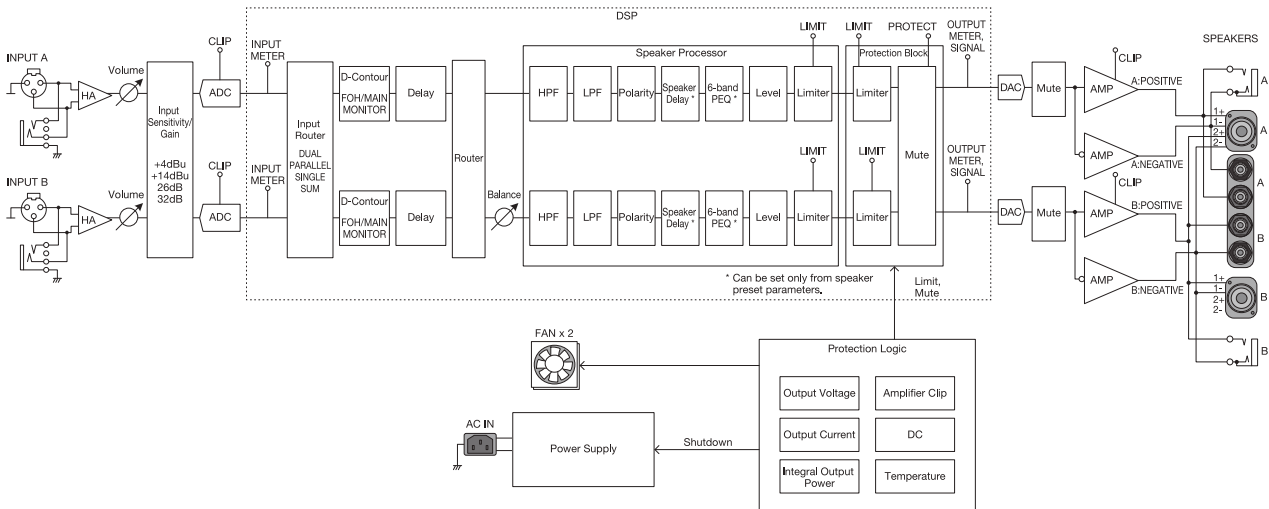

Block Diagram: MA2120/PA2120

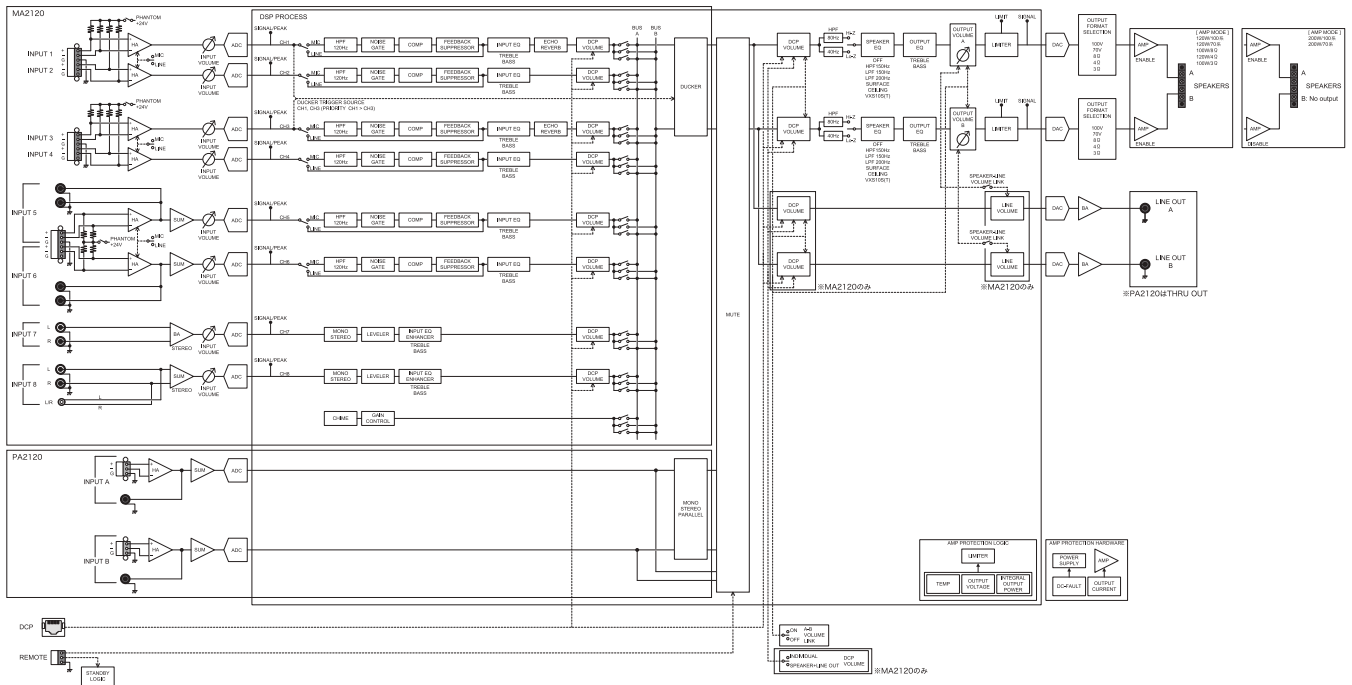

Block Diagram: MA2030a/PA2030a

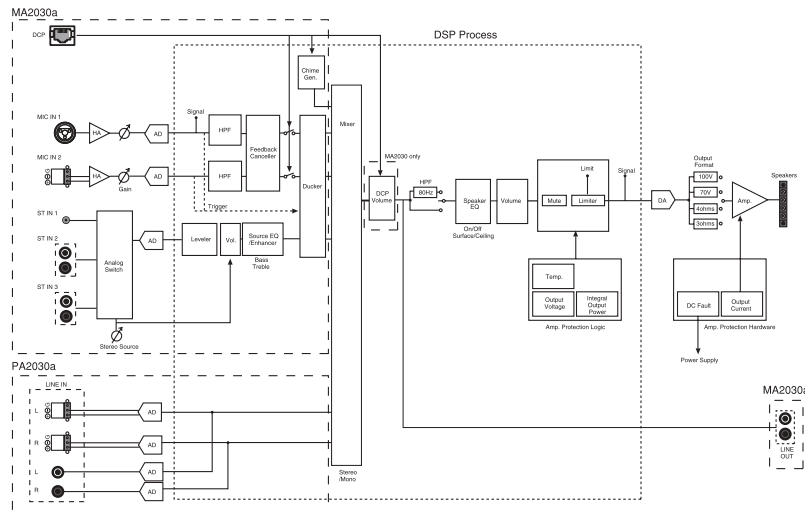

Block Diagram: DZR Series

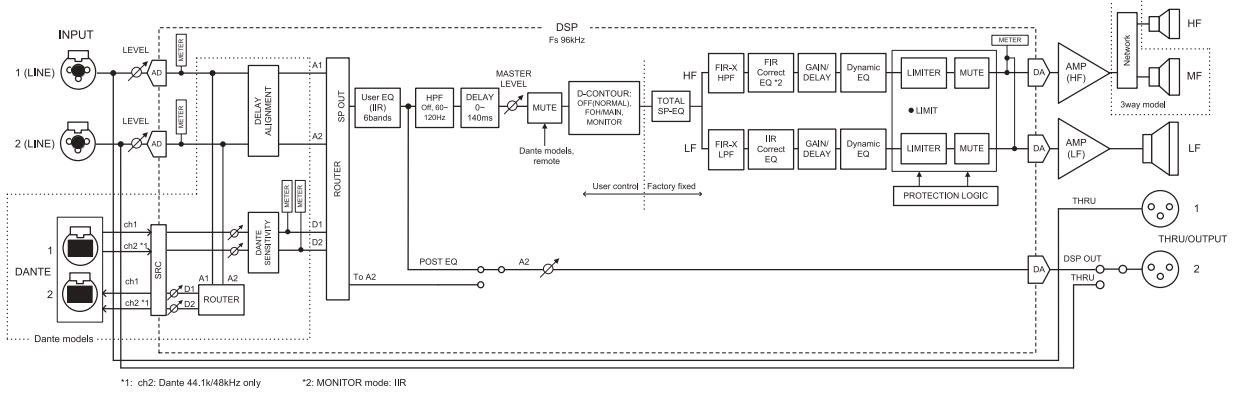

Block Diagram: DXRmkII Series

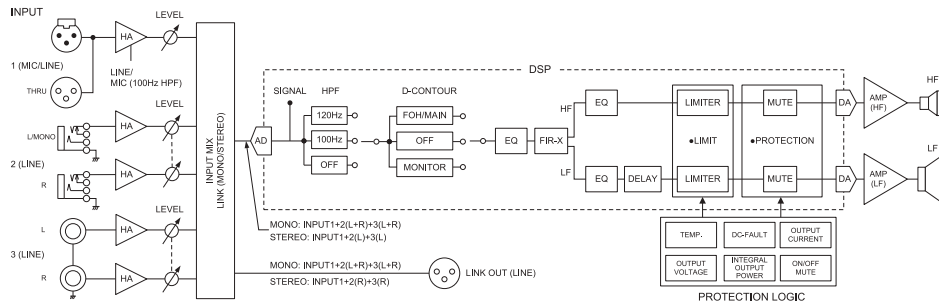

Block Diagram: DHR Series/DBR Series

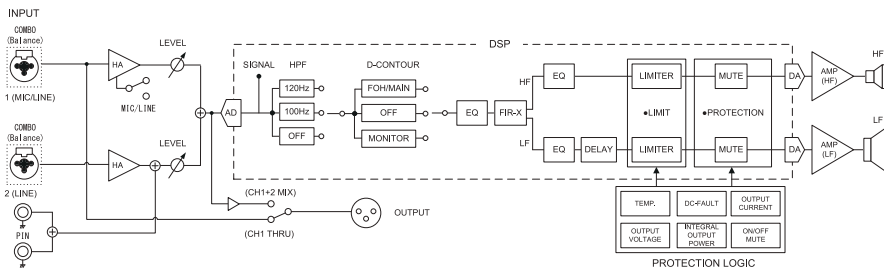

Block Diagram: DXL1K

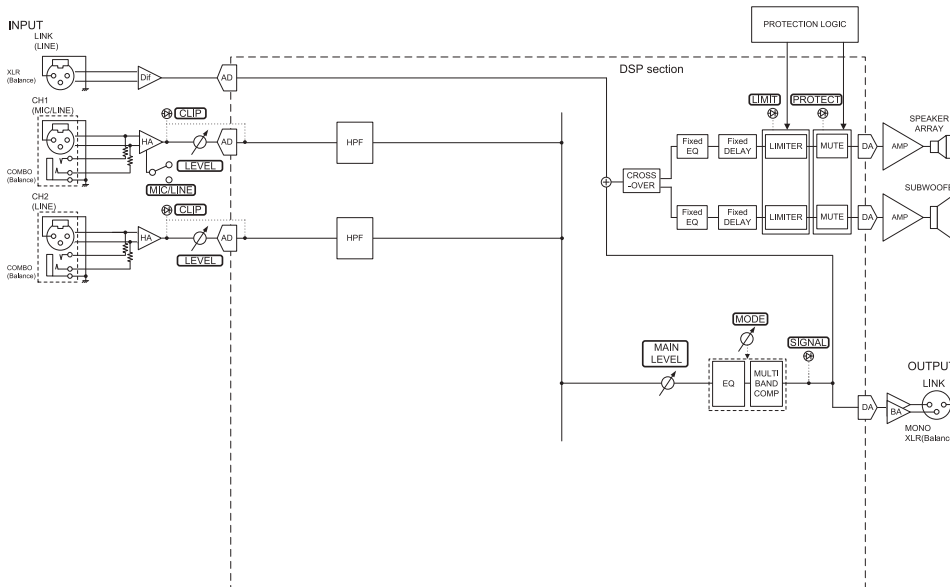

Block Diagram: DXS XLF Series

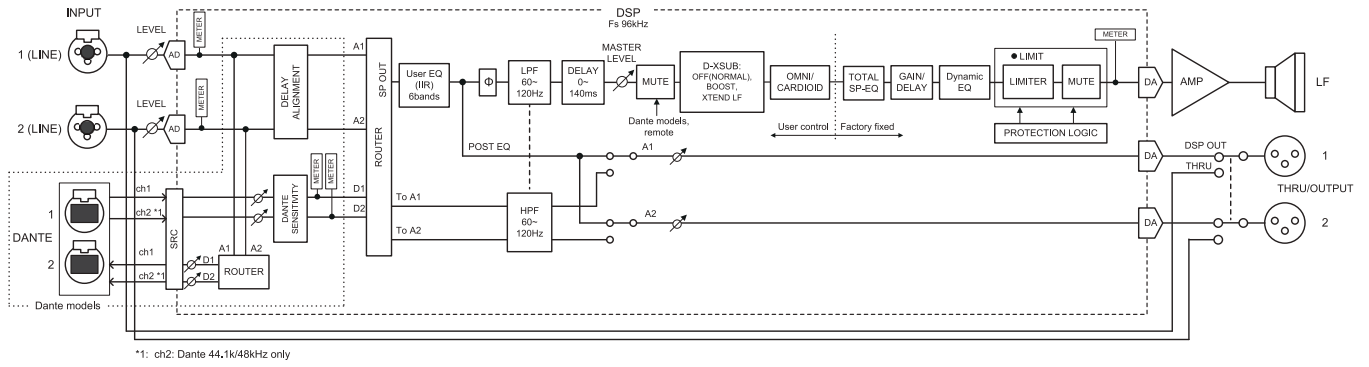

Block Diagram: DXS18/DXS15mkII/DXS12mkII

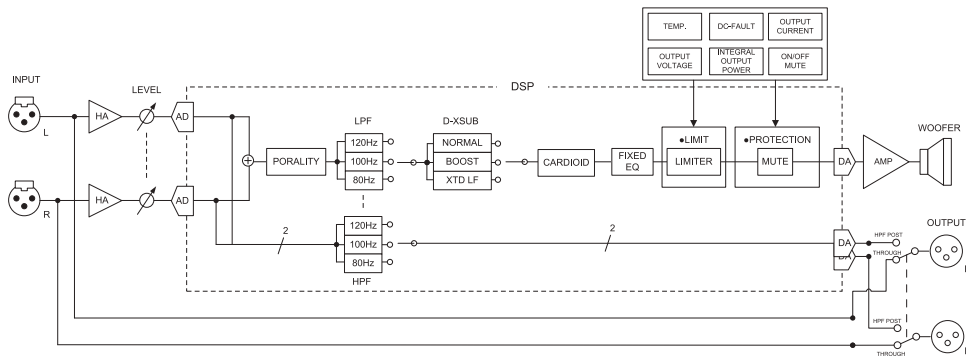

Block Diagram: CZR Series, Passive mode (Factory setting)

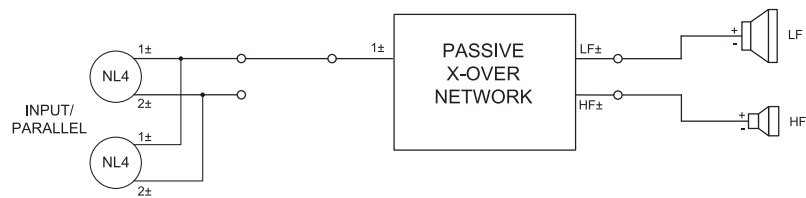

Block Diagram: CZR Series, Bi-amp mode (Selectable)

