



MUSIC SYNTHESIZER

MODX MS

MODX M7

MODX MS

Operation Manual

About this document

Information

- The illustrations and LCD screens as shown in this Operation Manual are for instructional purposes only.
- Unless indicated otherwise, the illustrations and displays as shown in this Operation Manual are based on the MODX M6 (in English).
- Windows is a registered trademark of the U.S. Microsoft Corporation in the U.S.A and other countries.
- Lightning and Mac are trademarks of Apple Inc. registered in the U.S.A. and other countries.
- MIDI is a registered trademark of the Association of Musical Electronics Industry (AMEI).
- The MIDI 2.0 logos ( **MIDI**) are trademarks or registered trademarks of the Association of Musical Electronics Industry (AMEI) and THE MIDI MANUFACTURERS ASSOCIATION INCORPORATED (MMA).
- The company names and product names in this manual are the trademarks or registered trademarks of their respective companies.

Indications in this document

Model name

MODX M6, MODX M7, and MODX M8 are collectively referred to as "MODX M."

Others

Attribute	Description
NOTICE	Indicates that malfunction, failure, or data loss may occur.
NOTE	Indicates supplemental information.
[]	Button or terminal name printed on the product

Contents

About this document.	2	6. Screens and parameters	71
1. How the MODX M Works.	4	Navigation bar	71
What is the MODX M?	4	Performance Screens	73
Tone generator block	5	Common Edit Screens	153
Internal memory	8	Part Edit (AWM2) Part Common Edit Screens	195
2. Setting up for Live Performance	10	Part Edit (AWM2) Element Edit Screens	239
Selecting a Performance	11	Drum Part Edit (AWM2) Part Common Edit Screens	268
Using overall functions for the entire Performance	16	Drum Part Edit (AWM2) Key Edit screen	279
Editing the settings	19	Part Edit (FM-X) Part Common Edit Screens	286
Saving edited settings	36	Part Edit (FM-X) Operator Edit Screens	303
Creating a Live Set	37	Part Edit (AN-X) Part Common Edit Screens	310
Selecting Performances from a Live Set	41	Part Edit (AN-X) Oscillator Edit Screens	336
Playing the keyboard	42	Part Edit (AN-X) Noise Edit Screens	342
3. Recording and Playback.	43	Category Search Screens	343
Terminology	43	Live Set Screens	356
Recording and playing back patterns	44	Utility Screens	361
Recording and playing back songs	47	Screens shown by pressing specific buttons	387
Recording audio and playing back audio files	50	7. Other information	400
4. Managing Back Ups	52	Effect types	400
Available file formats	52	Effect parameters	404
The USB flash drive will be formatted	54	Shortcuts and special operations	424
Saving settings to a USB flash drive	55	Message List	426
Loading settings from a USB flash drive	57	When there's a problem	431
5. Connecting external MIDI instruments	58		
Connecting a microphone or audio device	58		
Connecting to a Computer or External MIDI Device	62		

1. How the MODX M Works

What is the MODX M?

Block diagram and data flow

This instrument consists of eight main functional blocks: Controller, Motion Sequencer, Tone Generator, Effects, Sequencer, Arpeggio, Envelope Follower, and A/D Input.

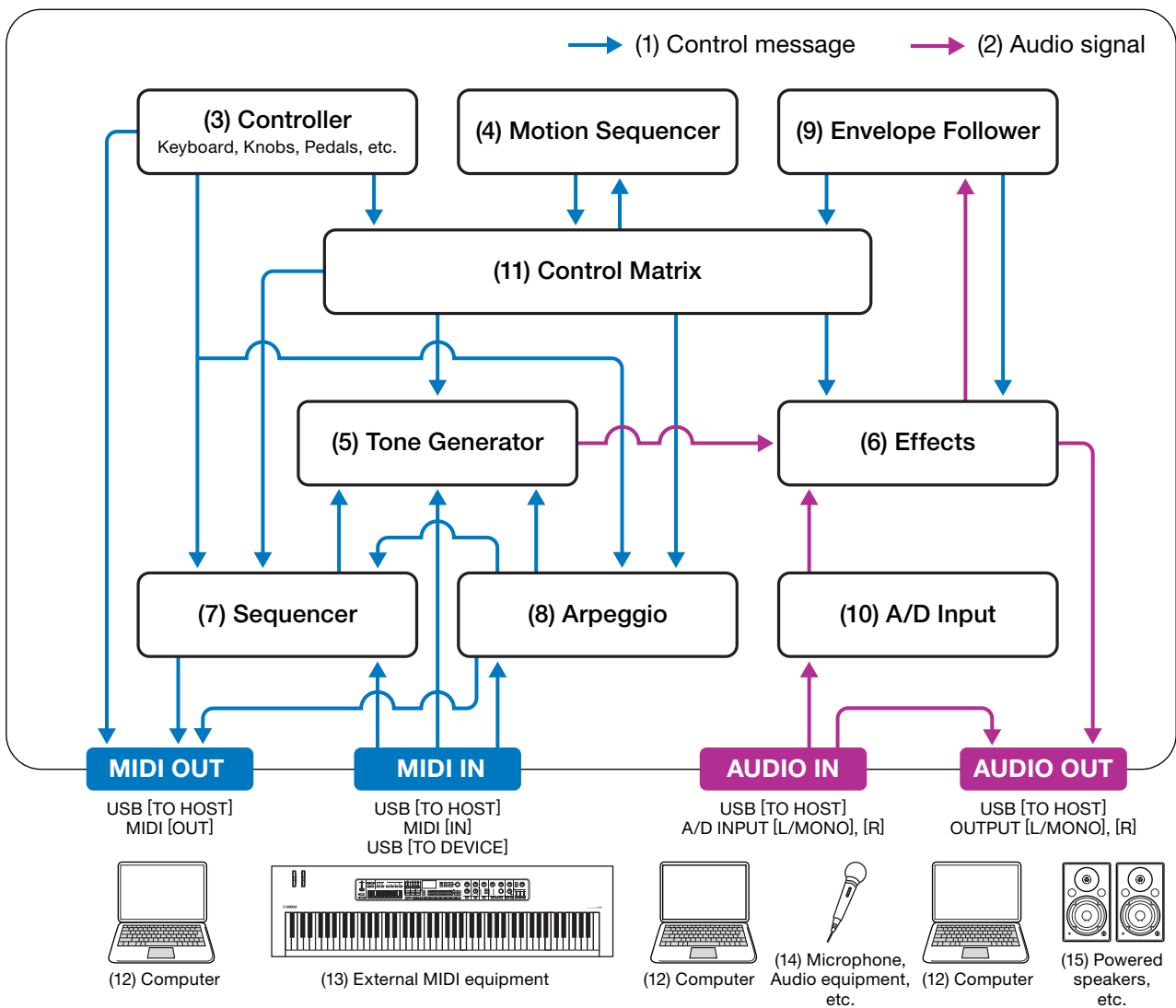

- (1) Control message
- (2) Audio signal
- (3) Controller
- (4) Motion Sequencer
- (5) Tone Generator
- (6) Effects

- (7) Sequencer
- (8) Arpeggio
- (9) Envelope Follower
- (10) A/D Input
- (11) Control Matrix
- (12) Computer

- (13) External MIDI equipment
- (14) Microphone, audio equipment, etc.
- (15) Powered speakers, etc.

Tone generator block

The tone generator block is equipped with a hybrid sound engine combining three synthesis systems.

AWM2 sound engine

The AWM2 sound engine features waveforms containing sampled wave data you can assign to each element, and then modify the sound by using Filters and EGs (envelope generators).

Normal Part

The Normal Part uses up to 128 elements to generate a wide range of rich sounds that help you create expressive sounds. The "raw" waveforms sampled from acoustic instruments are processed to be compatible with various different types of music, enabling the realistic reproduction of piano, wind instruments, and so on. You can also try creating new sounds using functions such as Filters and EGs.

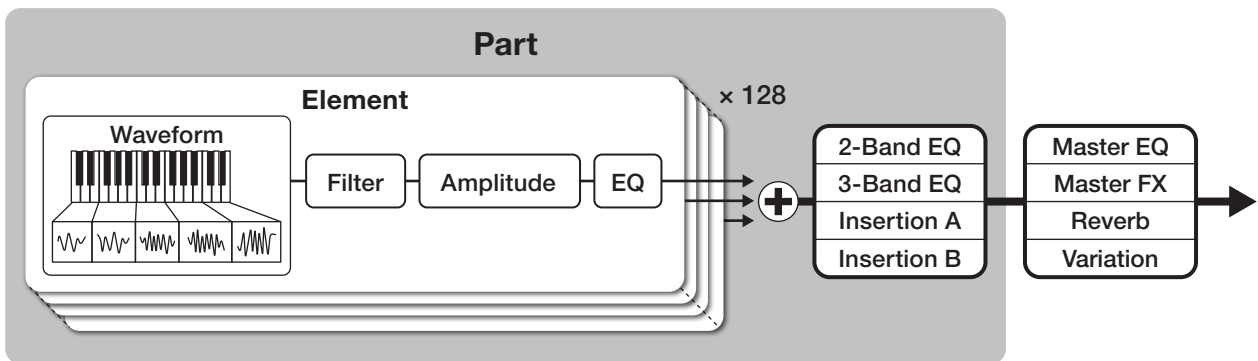

Drum Part

For the Drum Part, you can use up to 73 drum keys to assign the waveforms of percussion sounds to each key on the keyboard to create a desired drum kit.

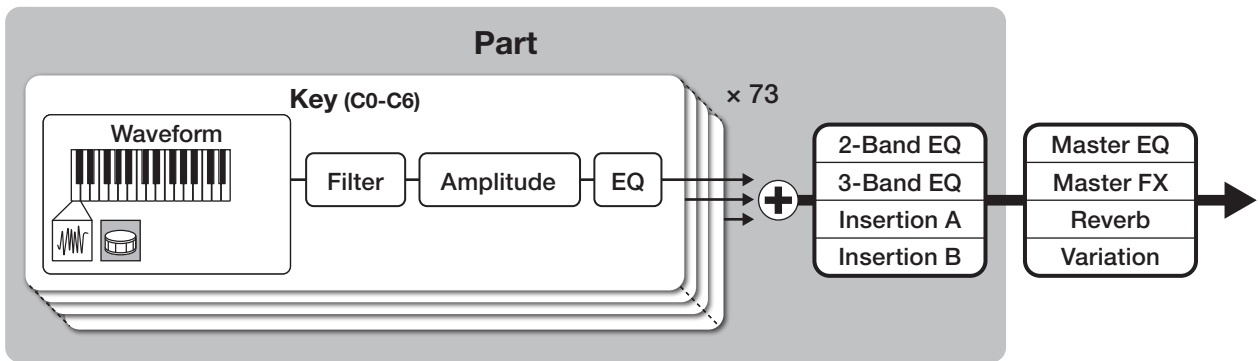

Individual drum sounds (different for each key) (C0 to C6)

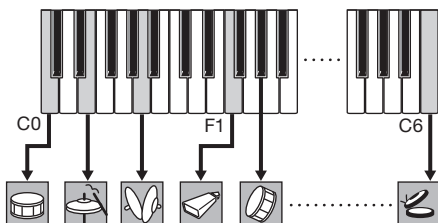

FM-X sound engine

The FM-X sound engine produces sounds with complex harmonics by frequency modulating (FM) eight waveform generators called "operators."

The arrangement of the eight operators is called an "algorithm," and there are 88 different patterns available. An operator has two roles: "carrier" and "modulator."

A modulator modulates the operator it is connected to, and sound is ultimately output from the carrier. It also has a "feedback" function that allows the operator to modulate the sound itself.

The harmonic structure of the operator's waveform can also be controlled with parameters, allowing you to apply the same high-quality filters, effects, EQ, etc. as the AWM2 sound engine to create expressive sounds that are difficult to create with conventional FM sound engines.

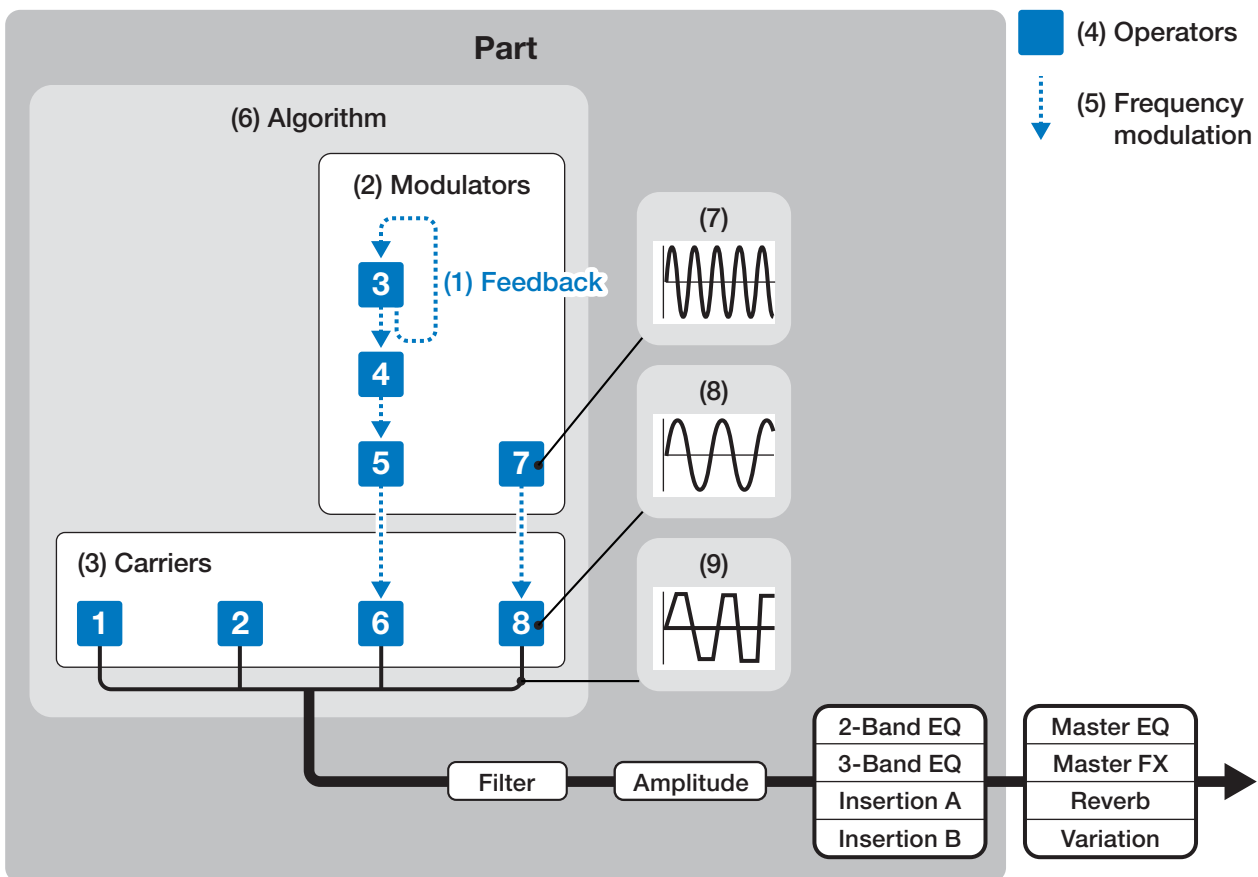

- (1) Feedback
- (2) Modulator
- (3) Carrier
- (4) Operator
- (5) Frequency Modulation

- (6) Algorithm
- (7) Modulator wave
- (8) Carrier wave
- (9) Modulated wave

AN-X sound engine

The AN-X sound engine is a virtual analog sound engine that fully digitally reproduces the behavior and characteristics of analog synthesizers. It is a new-generation AN sound engine that combines elements of tradition and innovation, and can express a wide range of sounds from realistic vintage sounds to edgy, extreme sounds.

The AN-X sound engine consists of three oscillators and one noise generator. Each oscillator is equipped with waveform control functions such as Pulse Width, OSC Self Sync, and Wave Shaper, allowing for great freedom in sound creation. In addition, Oscillator 3 (OSC 3) can modulate Oscillator 1 (OSC 1) and Oscillator 2 (OSC 2) using FM or ring modulation, and the output destination of each oscillator can be set to before or after Filter1 or Filter2.

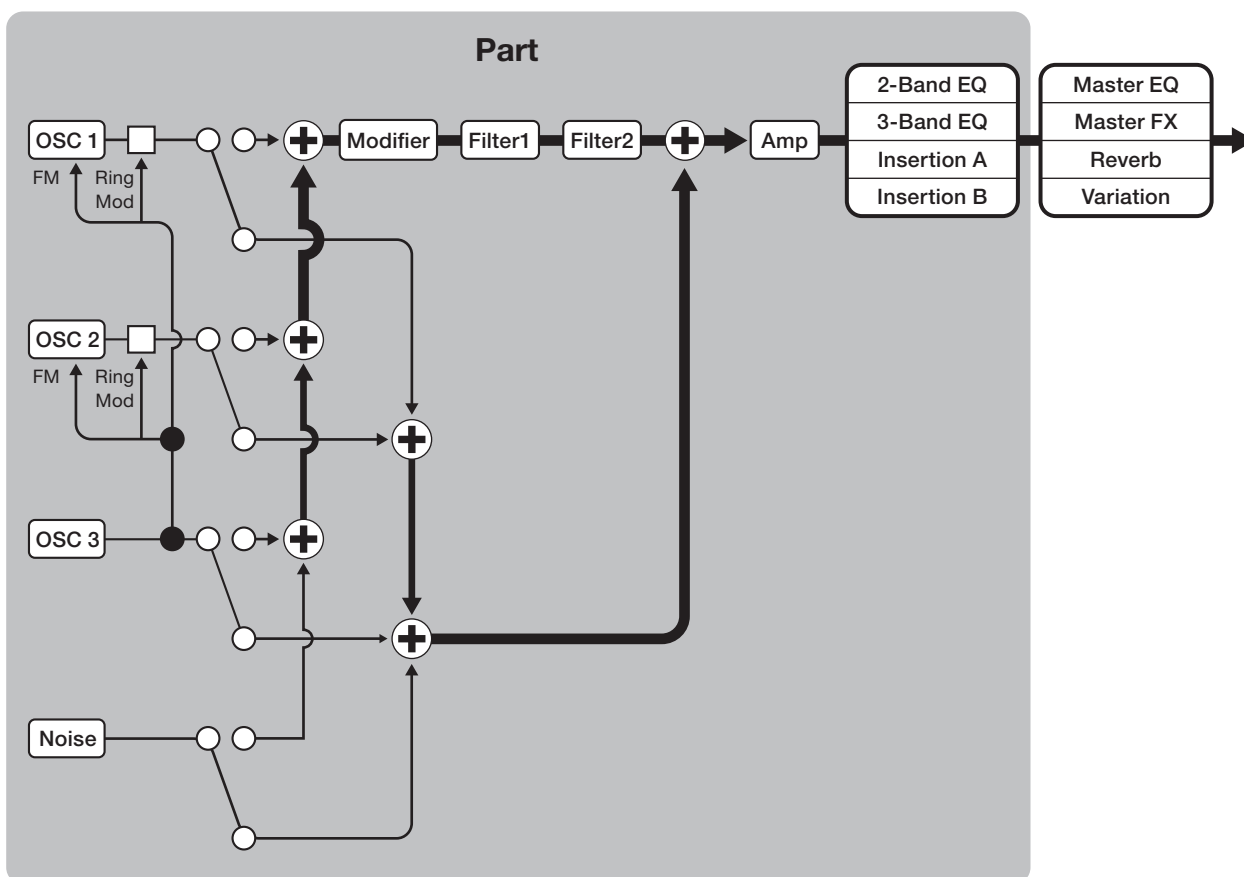

Internal memory

The internal memory of this instrument holds the saved Performances, Live Sets, Songs, and other settings. This chart shows the data flow between the internal memory and the external device.

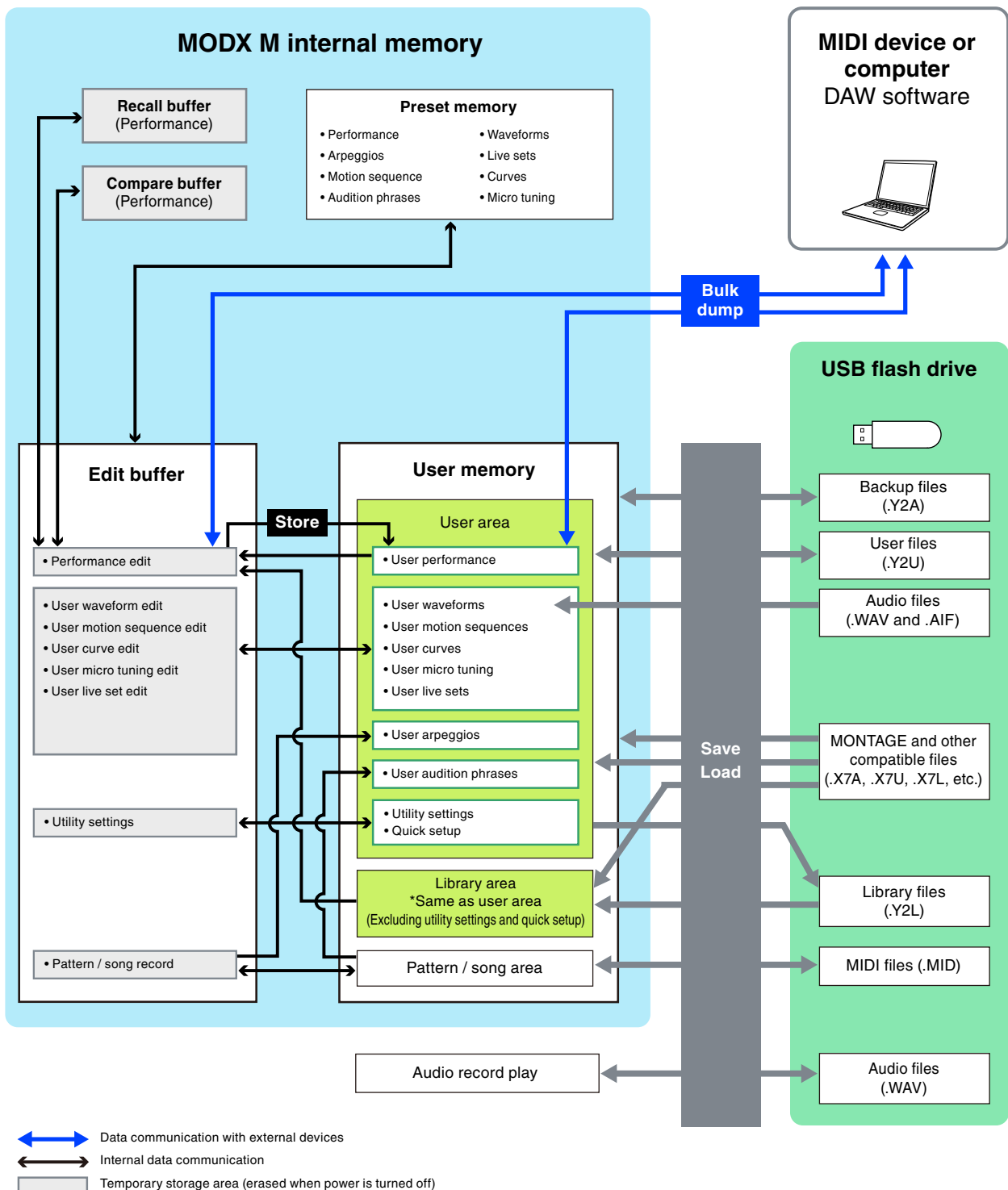

Preset memory

Contains the Preset Performances, Preset Arpeggios, Preset Audition Phrases, and other settings. You cannot overwrite the data in the Preset memory since it is read-only.

Edit buffer

The Edit buffer is the work area for editing Performances, Live Sets, Songs, and other settings.

This work area allows both reading and writing, and the contents within this work area are erased when the instrument is turned off.

Edited data must be saved to User memory before switching Performances or turning the instrument off (however, data other than Performances and Motion Sequences is saved automatically).

User memory

The User memory has two areas: User and Library.

User area

The User area holds the stored Performances and Motion Sequences, and other settings for the entire instrument, such as Utility settings and other User data edited in the Edit buffer.

When a User Performance is edited, you can store it as a new Performance or overwrite the existing Performance.

Library area

The Library area allows up to 24 library files (.Y2L) to be loaded from the USB flash drive. The settings saved in the Library area cannot be edited. To edit the settings in the Library area, send the data to the Edit buffer by selecting a Performance stored in the Library area or loading a Motion Sequence from the Library area. After editing, the data will be stored in the User area.

The User memory is used for reading and writing, and the data within this area will be retained after the instrument is turned off.

Recall buffer and Compare buffer

The Recall buffer and Compare buffer are areas used for temporarily saving the settings you are editing.

Recall buffer

The Recall buffer is used as a backup for the Edit buffer.

If you accidentally changed to a different Performance without first storing the setting, you can use the Recall function to restore the temporarily saved settings from the Recall buffer to the Edit buffer.

Compare buffer

The Compare buffer is the area for keeping settings before making edits. By using the Compare function, you can bring the settings temporarily saved in the Compare buffer to compare the edited and unedited sounds.

These buffers are for reading and writing data, but the settings will be lost when the instrument is turned off.

2. Setting up for Live Performance

Shown below is a general workflow guide for this instrument.

Selecting a Performance

Select from the Live Set screen or from the Performance screen (Category Search screen).



Editing the settings



Saving edited settings



Creating a Live Set



Selecting a Live Set



Playing the Keyboard

Selecting a Performance

Selecting on the Live Set screen

1. Press the [LIVE SET] button.

The Live Set screen will open.



2. Tap to select the Performance you want from the displayed list.

Selecting on the Category Search screen

The Category Search function allows you to search through Performances, Parts, Rhythm Patterns, Arpeggios, and Waveforms to find ones you would like to use. To search for a Performance, press the [CATEGORY] button with the Performance screen open to open the Performance Category Search screen.

Even while the Category Search screen is displayed, you can switch parts and mute using the buttons on the top panel.

NOTE

You can also select a Performance by moving the cursor to the Performance name on the Home screen and using the Data dial, [INC/YES] button, or [DEC/NO] button.

Screen description

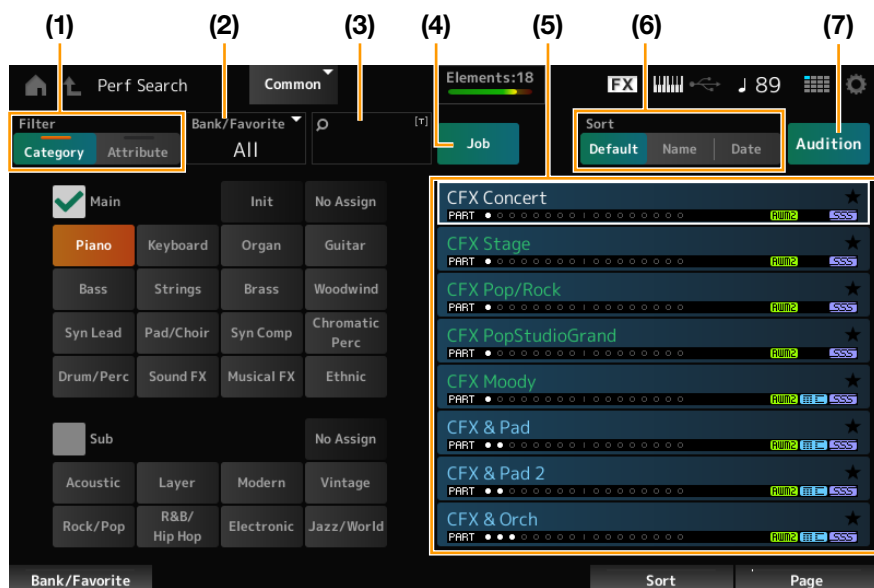

(1) Filter

You can use the filter to search through the list of Performances.

- **Category**

You can select one each from Main and Sub.

- **Attribute**

Select an attribute or combinations of attributes. The filter will vary depending on the combination.

Filter:

Exact match	AWM2, FM-X, AN-X
AND condition	MC, SSS, Smart Morph
OR condition	Single, Multi MOTIF XF, MONTAGE, MODX M OS Vx.x (x.x is the OS version number)

NOTE

“MONTAGE” includes MODX and MODX+.

(2) Bank

(3) Search by keyword

(4) Job

(5) List of Performances

The Performances that correspond to the selected Category and Attribute are displayed.

Text color	Description
White	Currently selected Performance
Green	Single-Part Performance
Blue	Multi-Part Performance

(6) Changing the sort order

(7) Audition

Procedure

1. Press the [CATEGORY] button.

The Performance Category Search screen appears.

This screen can also be opened by selecting Category Search from the context menu for the Performance Name.



2. Use the filter as needed.

Search the Performances by switching filters, banks, and sorting.

3. Select from the list.

Select from the list of Performances displayed on the right side of the screen.

Use the Data dial, [INC/YES] button, [DEC/NO] button, or up and down buttons to make your selection.

You can also use the Display knob to scroll through the screen without changing the currently selected Performance.

4. Close the screen.

Press the [ENTER] button, [EXIT] button or [PERFORMANCE (HOME)] button on the top panel, or tap the [HOME] (HOME) icon or [↵] (EXIT) icon on the screen.

NOTE

You can use the Part Category Search function if you wish to change one of the Parts in a Multi-Part Performance (a Performance that has more than one Part). Select the Part you wish to change, then press the [CATEGORY] button while holding down the [SHIFT] button to display the Part Category Search screen.

Selecting an Initialized Performance or a Single-Part Performance

Initialized Performance

Set Bank/Favorite to either All or Preset.

Set the filter to Category and select Init.

Single-Part Performance

Set the filter to Attribute and select Single.

Playing back an audition phrase

By playing back the audition phrase, you can check the Performance. You can also hear how the sound of the Performance changes by manipulating the controller during playback.

1. Press the [AUDITION] button on the top panel or tap Audition on the Category Search screen.

The Audition phrase of the current Performance will be played back.

If you switch Performances during playback, the phrase from the new Performance will be played back.

NOTE

If the [AUDITION] button is turned off, the audition function is not available for the selected Performance, and nothing happens when you press it.

2. To stop the playback of the audition phrase, press the [AUDITION] button on the top panel once more, or tap the Audition button on the Category Search screen.

Using overall functions for the entire Performance

There are other functions for adjusting the balance between Parts within the Performance or for quickly switching to different groups of settings that have been registered to the buttons in advance.

Mixing

The Mixing function allows you to adjust the balance between Parts.

You can check the settings for each Part, such as Pan, Volume, and EQ, and adjust the parameters.

Screen description

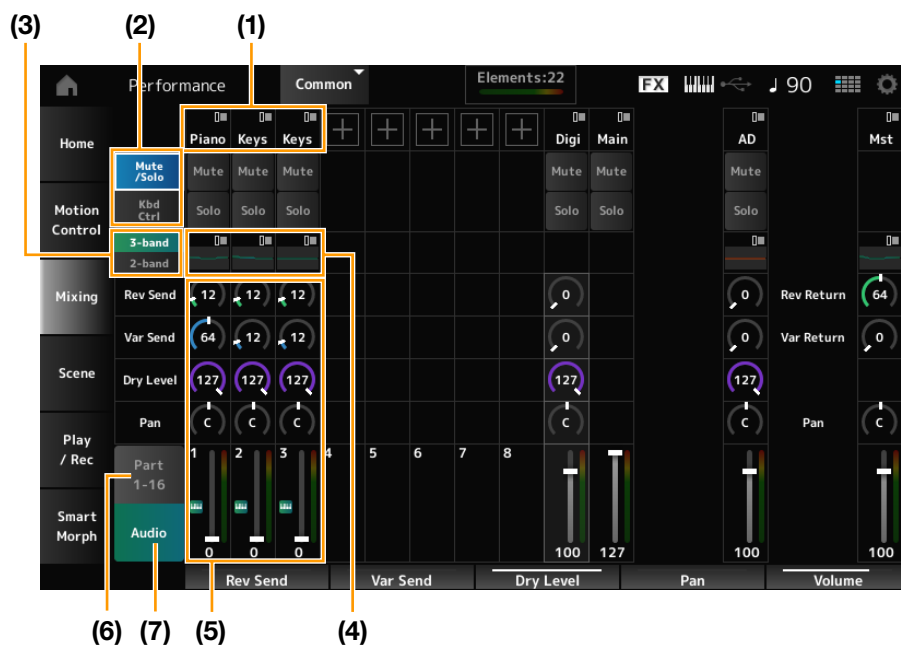

(1) Main category for each Part

(2) Switching views for Solo, Mute, and Kbd Ctrl

(3) Switching between 3-band EQ and 2-band EQ

(4) EQ settings for each Part

(5) Parameters for each Part

(6) Switching to 16-part view

(7) Switching to Audio Part view (Parts 9 to 16 hidden)

You can set the following audio parameters for an Audio Part.

- AD part: Audio input from the A/D INPUT jacks
- Digital part: Audio input from the USB [TO HOST] terminal

* Refers to the audio set to Digital L/R in audio channels

Procedure

1. Press the [PERFORMANCE (HOME)] button and tap Mixing.

The Mixing screen appears.

2. Select a Parameter.

Select a Parameter by using the PART buttons or cursor buttons, or tap the icons and buttons on the screen.

3. Change the value by using the Data dial or relevant Display knob.

NOTE

If you need to fine-adjust the value, press the [EDIT/↶] button while the Mixing screen is shown on the display to open the Edit screen.

Scene

The Scene is a “snapshot” of various settings, such as Arpeggio type, Motion Sequence type, and Part parameters. By registering different Scenes to each of the eight SCENE buttons, you can use the SCENE buttons to recall different settings instantly.

This would be convenient, for example, when you wish to change only the Arpeggio and Motion Sequence types, without changing the Performance, to follow the progression of a song, or to bring out a different aspect of a Performance.

Screen description

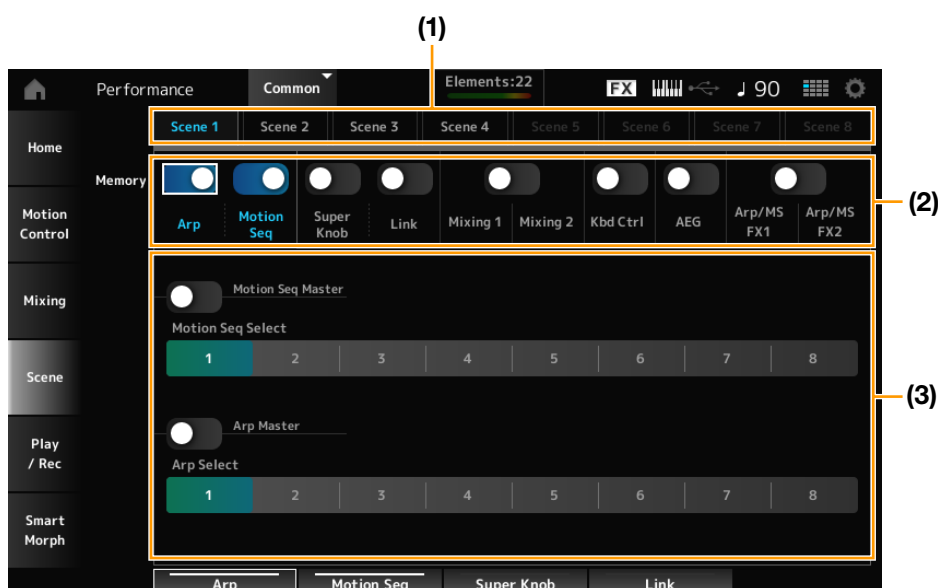

(1) Scene tab

(2) Memorize switch

(3) Settings for the tab

When the Memorize switch is On, the parameters for the function appear on the screen.

Procedure

1. Press the [PERFORMANCE (HOME)] button and tap Scene.

The Scene screen appears.

2. Set up Scene 1–8.

The functions to which Memorize Switch (Memory) has been set to On will be registered to the selected SCENE button.

The newly set Scene now becomes active when you press the appropriate SCENE button.

3. Press the [STORE] button to save the Performance.

NOTICE

Make sure to save (store) the Scene settings you have just edited before changing to a different Performance or turning off the instrument. Without performing the Store operation, the Scene settings will be lost.

NOTE

If a Parameter that can be registered to the SCENE button has already been assigned to a knob or slider, operate that. You can then register the settings to a button by holding down the [SHIFT] button and pressing one of the SCENE buttons. After that, press the [STORE] button to save the Scene settings to the Performance.

Editing the settings

Using Split and Layer

What is Split?

This setting divides the entire keyboard into multiple groups and assigns a Part to each group. On this instrument, you can specify the split point and set the key range for each group.

What is Layer?

This setting allow you to combine multiple Parts on top of each other and play them simultaneously. By assigning two or more Parts to the same group, you can play a combination of multiple tones.

Split Job Screen

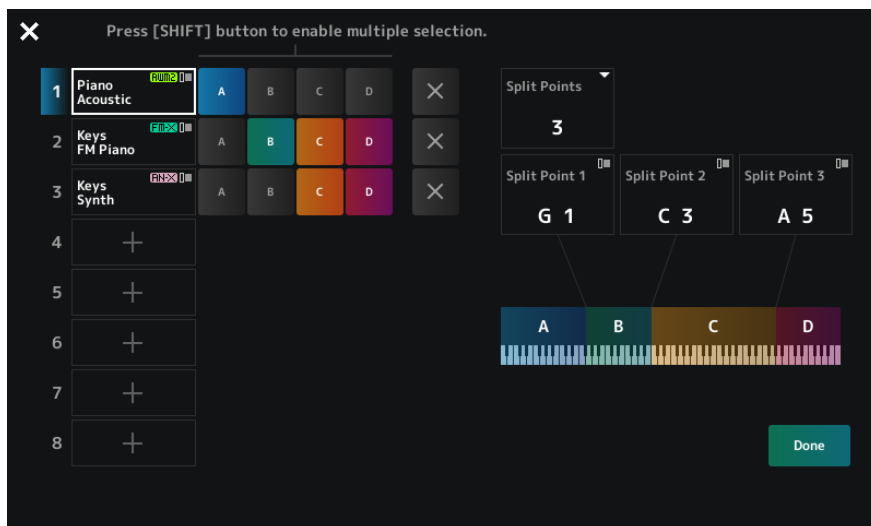

For a description of each item on the screen, refer to Split Job.

Split setting procedure

1. Press the [SPLIT] button.

The Split Job screen for the Performance appears.

2. By tapping the items on the screen to specify the number and position for the Split Point, you can set the key range for each group.

Tap the group buttons while holding down the [SHIFT] button to assign a single Part to multiple groups.

3. Press the [EXIT] button or tap Done on the screen to confirm the settings.

Tapping [x] (Close) on the upper left cancels the setup.

Note range setting procedure

1. Hold down the [SHIFT] button and press the [SPLIT] button.

The Part - Note view is shown on the Performance screen.

2. Use the keyboard or Data dial to change the note range for each Part.

Procedure for editing

1. Select a Performance.
2. On the Performance screen, move the cursor to the desired Performance name or Part you want to edit.
3. Press the [EDIT/↶] button or tap Edit in the context menu.
The Common Edit screen will appear when the cursor is on the Performance name.
The Part Edit screen for the sound engine will appear when the cursor is on the Part.

NOTE

You can change the Parameter to be edited by opening the Common Edit screen on the Edit screen and selecting the desired item from the Navigation bar.

4. Select a tab on the first and the second rows to open the screen.
Changing the settings in each tab from the top to the bottom is recommended.

Example: Normal Part (AWM2)



5. Edit the settings by changing the parameters shown on the right of the tabs.
6. Continue editing the parameters on different tabs if necessary.
The target for editing will be shown on the navigation bar.
Select Common for editing the settings for the entire Performance.
Select Part Common for editing the settings for the entire Part.
If you wish to go into detailed settings, select one of the following: Element 1–128, Operator 1–8, Oscillator 1–3, Noise, and C0–C6.



7. When you've finished editing, press the [STORE] button to save the Performance.

Using the Navigation screen

1. Press the [NAVIGATION] button.

The NAVIGATION screen appears.

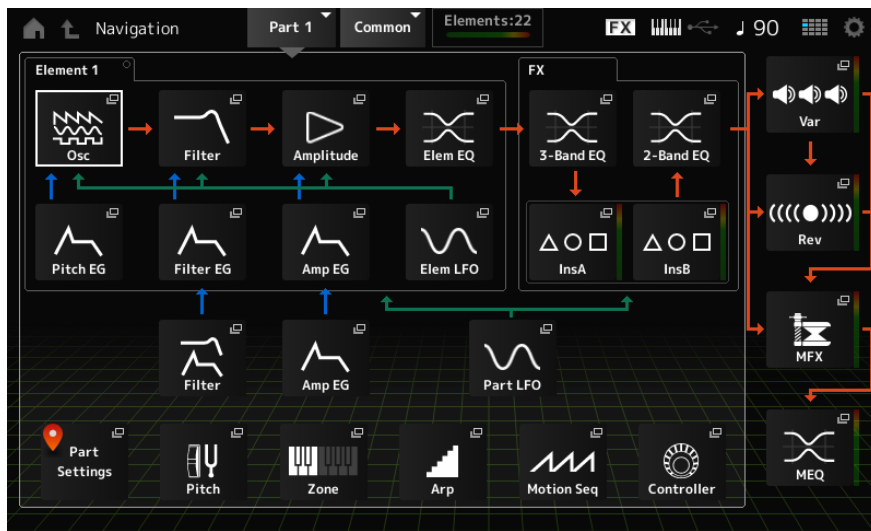

Pressing the [NAVIGATION] button during editing calls up the current location icon (📍).

2. Select the item for editing.

Select Part Common for editing the settings for the entire Part.

If you wish to go into detailed settings, select one of the following: Element 1–128, Operator 1–8, Oscillator 1–3, Noise, and C0–C6.

3. Select the icon for the Parameter you want to edit.

Use the cursor buttons to move the cursor, and press the [ENTER] button. Or, tap the icon on the screen.

4. Select the icon for the setting you want to edit.

5. Change the parameters shown on the screen.

6. Save the Performance.

Creating tonal changes

For creating tonal changes, you can use Oscillators, filters, EGs (or Envelope Generators), LFOs (or Low-Frequency Oscillators), and effects. By changing those parameters, you can change the brightness, resonance, or other timbral qualities of the sound.

The detailed settings vary depending on the sound engine, but the common settings are as follows:

Oscillators (Osc)	Creates a waveform
Pitch (Pitch)	Controls the pitch
Filters (Filter)	Controls the cutoff frequency
EG	Determines how the sound changes over time
LFO	Determines the cyclical change of the sound
Motion Sequencer	Creates complex changes to the sound over time
Effects (Effects)	Processes the sound

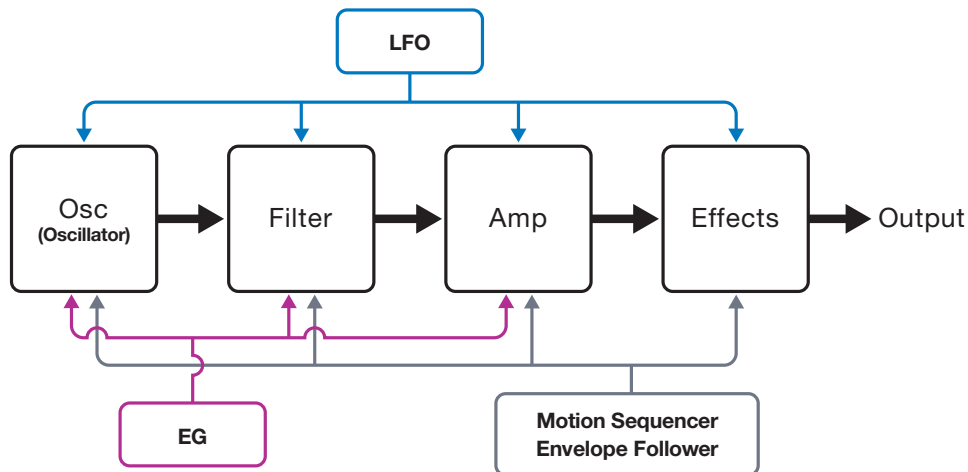

Effect configuration

System Effect

This effect is applied to all Parts of the Performance.

The System Effect include two types: Variation and Reverb. You can also add Reverb to the Variation's output sound (Variation to Reverb).

Insertion Effect

This effect is applied to each Part.

Master Effect

This effect is applied to the overall sound at the final output.

Part EQ

A 3-band and 2-band equalizer that is applied to each Part.

The Part EQ can be applied before or after the Insertion Effect.

Master EQ

A 5-band equalizer that is applied to the overall sound at the final output.

Effect connections and settings

Connect as shown in the diagram below and set up each one using methods (1) to (4).

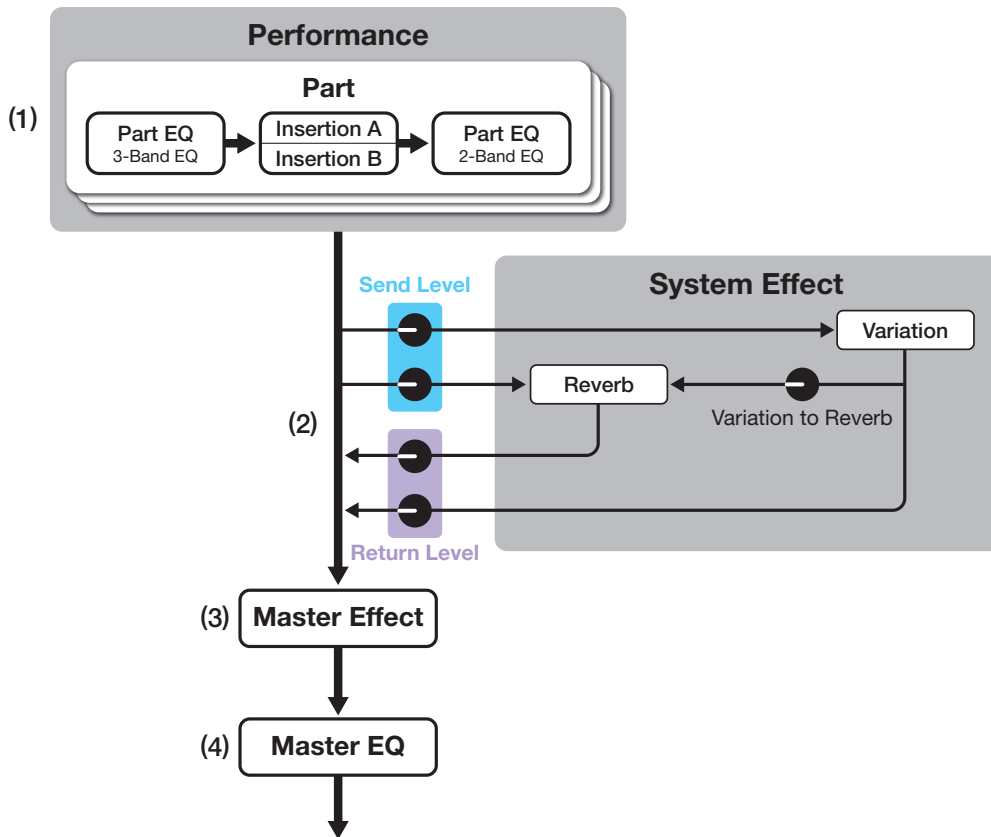

(1) Setting the Part EQ and Insertion Effect

[PERFORMANCE (HOME)] → Part selection → [EDIT/↺] → Effect → Routing

[PERFORMANCE (HOME)] → Part selection → [EDIT/↺] → Effect → Ins A

[PERFORMANCE (HOME)] → Part selection → [EDIT/↺] → Effect → Ins B

[PERFORMANCE (HOME)] → Part selection → [EDIT/↺] → Effect → 3-band EQ

[PERFORMANCE (HOME)] → Part selection → [EDIT/↺] → Effect → 2-band EQ

(2) Setting the Variation and Reverb

[PERFORMANCE (HOME)] → Part selection → [EDIT/↺] → Effect → Routing

[PERFORMANCE (HOME)] → Common selection → [EDIT/↺] → Effect → Variation

[PERFORMANCE (HOME)] → Common selection → [EDIT/↺] → Effect → Reverb

(3) Setting the Master Effect

[PERFORMANCE (HOME)] → Common selection → [EDIT/↺] → Effect → Master FX

(4) Setting the Master EQ

[PERFORMANCE (HOME)] → Common selection → [EDIT/↺] → Effect → Master EQ

NOTE

Set the effect for the audio input signal from the A/D INPUT jacks as follows: [PERFORMANCE (HOME)] → Common selection → [EDIT/↺] → Audio In.

For information on the effect category and effect types, refer to the Effect types. For information on the effect parameters, refer to the Effect parameters.

For information on the Preset program for each effect type, refer to the Data List.

Changing the Effect settings

By pressing the [NAVIGATION] button while holding down the [SHIFT] button, the FX Overview screen will appear, and you can see an overview of the effect settings. Tap the buttons on the effect names such as Ins A and Var to open the Edit screen.

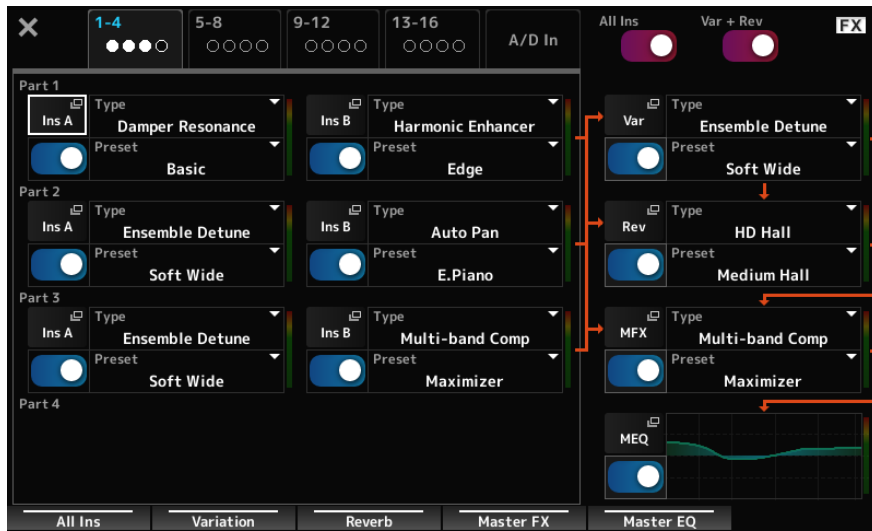

Using Arpeggio

Arpeggio is a function that automatically plays rhythm patterns and chord backings simply by pressing keys. It not only provides inspiration and full rhythmic passages in your live performances, but it gives you fully formed instrumental backing parts of various music genres for ease in creating songs.

Features of the Arpeggio function of this instrument

This instrument allows you to set up to eight Arpeggio types for each Part, and play back Arpeggios for eight Parts simultaneously.

You can also set the range of keys used for Arpeggio playback (Note Limit) and the upper and lower limits of key pressure (Velocity Limit).

The Arpeggio function lets you play Accent Phrases (the sequence phrase played only when the keyboard is played at a higher velocity than the specified value) or effect sounds such as guitar fret noises using the Random SFX function. You can search for preset Arpeggios containing these sounds on the Arp Category Search screen. Specifying Accent (Accent Phrase) or Random SFX in Attribute will narrow down the Arpeggios that match.

Turning Arpeggio on and off

To turn the Arpeggio function on or off, press the [ARP] button on the top panel.

Changing Arpeggio by using the knobs

Select ARP/MSEQ with the [QUICK EDIT] button and use Knobs 1 and 2 to change the way the Arpeggio sounds. Modify the sound by turning the knobs and listening to the Arpeggio playback. For details on the effects of Knobs 1 and 2, refer to Arp/MS → Arp Common on the Common Edit screen.

Changing the way Arpeggio playback is turned on or off

You can freely change the Arpeggio playback method from a setting that plays only while you hold down the key to a setting that continues playing even after you lift your finger from the key, etc. Follow the steps below to change this setting:

Hold

[EDIT/↶] button → Part selection → Common → Arpeggio → Common

Trigger Mode

[EDIT/↶] button → Part selection → Common → Arpeggio → Advanced

Setting	Hold	Trigger Mode
Played back only while a key is being pressed	Off	Gate
Playback continues after the finger is lifted off from the key	On	Gate
Playback is turned on or off each time the key is pressed	Regardless of whether On/Off	Toggle

NOTE

When Arp Master and Arp Part are on, turn the [KEYBOARD HOLD] button on the top panel on to achieve the same effect as when Hold is On.

Using Motion Control

The Motion Control function lets you create Motion (rhythmic and dynamic sound changes) in real time, so you can find completely new ways of expression.

This function allows you to make the settings in advance so that you can change the parameters without actually operating the pedals or wheels.

This lets you create dramatic and powerful expressive changes that follow the beat of your music.

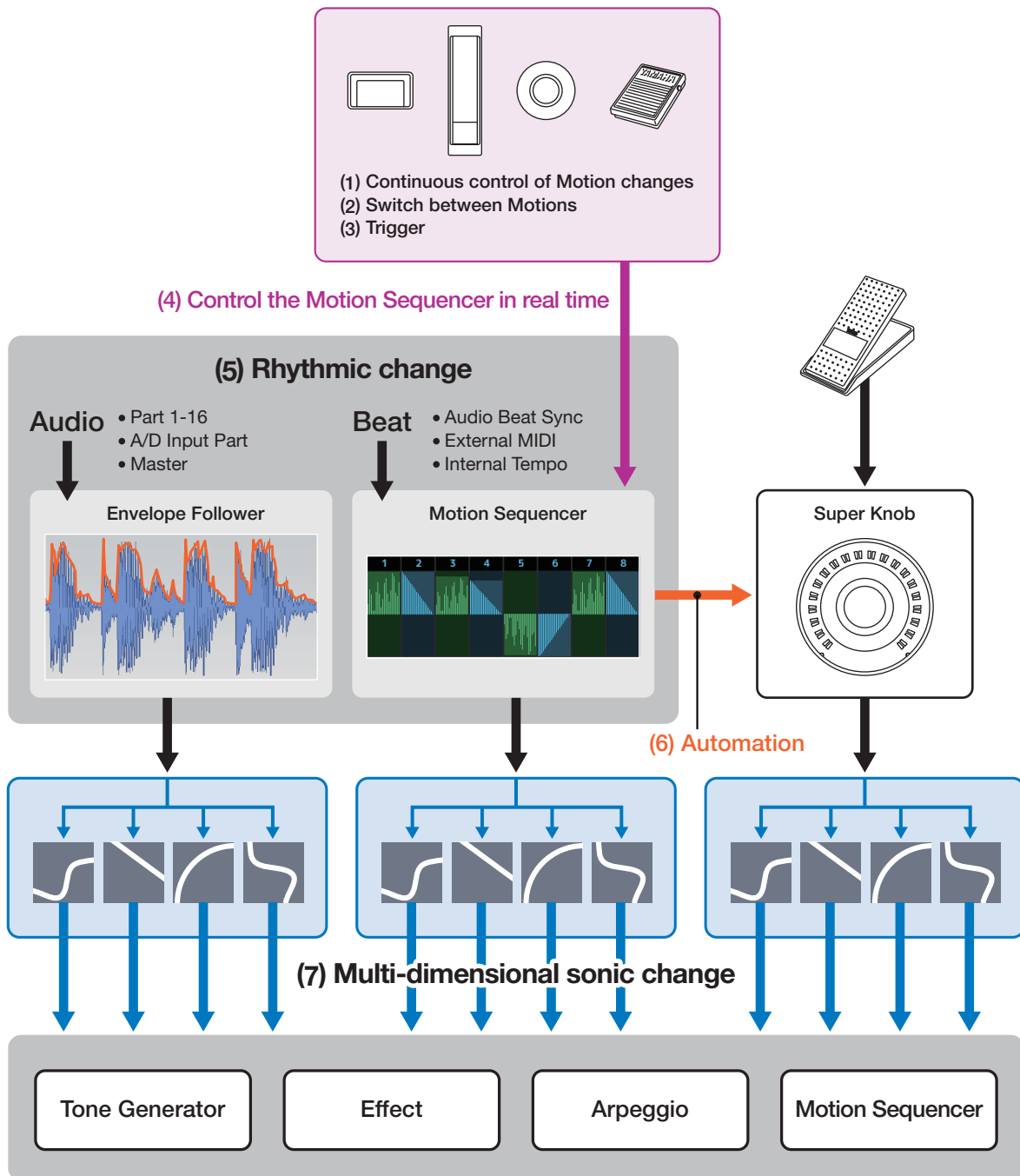

(1) Continuous control of Motion changes

(2) Switch between Motions

(3) Trigger

(4) Control the Motion Sequencer in real time

(5) Rhythmic change

(6) Automation

(7) Multi-dimensional sonic change

Setting Motion Control

Motion Control can be set by setting the Source for the Controller as well as the Destination and Parameter from the Control Assign screen.

How to open the Control Assign screen

[PERFORMANCE (HOME)] → Tap Common → [EDIT/⟳] → Control → Control Assign

[PERFORMANCE (HOME)] → Select Part → [EDIT/⟳] → Mod/Control → Control Assign

Setting to Super Knob

Set the Display Filter to SuperKnob, and select the Source (AsgnKnob 1–8), Destination, etc.

Setting to Motion Sequence

For Motion Sequence, set the Source to a Motion Sequence Lane from 1 to 4.

Setting to Envelope Follower

Set the Source to EnvFollow.

Customizing the Super Knob settings

By using the Super Knob, you can simultaneously control the Assign 1–8 values that are assigned to Knobs 1 to 8 that are common to all Parts.

By combining the Super Knob and the Motion Sequencer, you can achieve more complex sound changes.

Controlling the Super Knob from the pedals

You can control the Super Knob from the separately sold Foot controller (FC7) connected to this instrument.

1. Connect the Foot Controller (FC7) to the FOOT CONTROLLER jack ([1] or [2]).
2. Open the screen from: [PERFORMANCE (HOME)] → [EDIT/⟳] → Control → Control Number.
3. Select SuperKnob for Foot Ctrl1 or Foot Ctrl2, depending on the jack you have connected the Foot Controller (FC7) to.

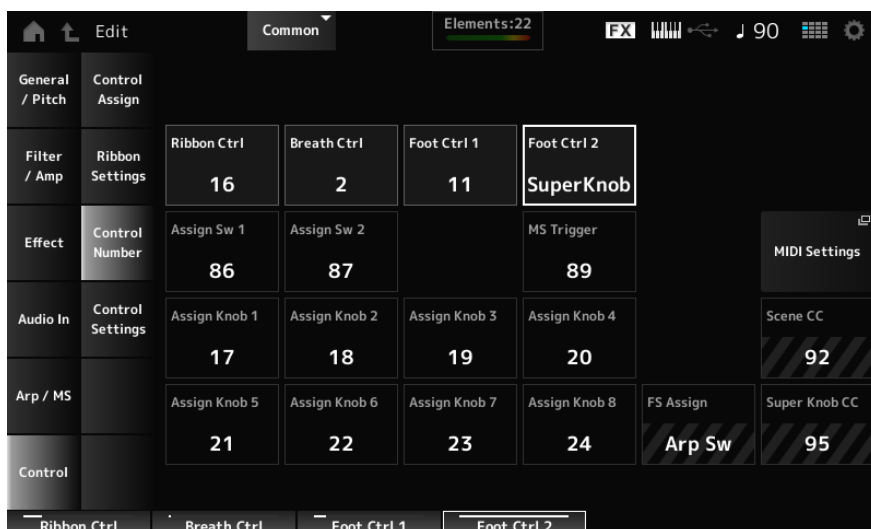

4. Close the screen to finish the setup.

An example of a Super Knob setting

The Super Knob settings can be customized.

You can set two or three fixed values for using the Super Knob for morphing sounds. With three fixed values, you can set the median value.

An example of morphing using three fixed values

Here, we will explain how to add morphing effects to the layered sound made with three Preset Performances (acoustic piano, pad sound, and electric piano). Additionally, we'll explain how to add a morphing effect while keeping the original settings for these Performances.

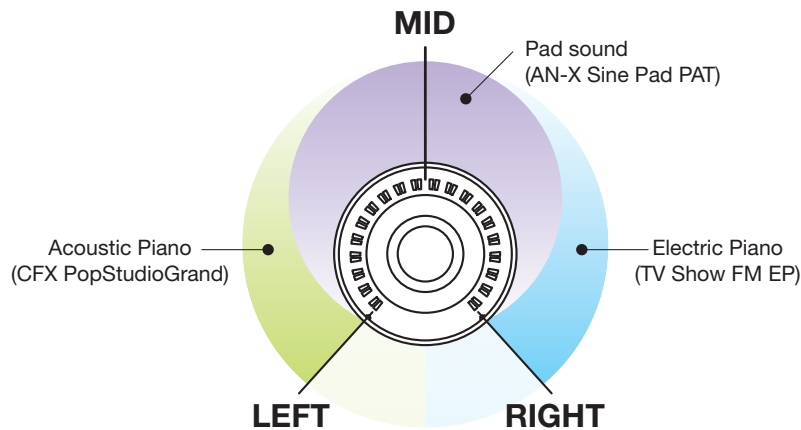

1. Select sounds for Parts 1 to 3.

1-1. Press the [CATEGORY] button and select CFX PopStudioGrand.

1-2. From the Home screen, tap the [+] icon for Part 2 to open the Part Category Search screen and select AN-X Sine Pad PAT.

1-3. From the Home screen, tap the [+] icon for Part 3 to open the Part Category Search screen and select TV Show FM EP.

2. Set the parameters for Part 1.

2-1. Select Part 1.

2-2. Press the [CONTROL ASSIGN] button while holding down the [SHIFT] button to open the Control View screen.

2-3. Turn the Super Knob to open the Control Assign screen.

2-4. Go to Page 2 and tap the [+] icon to add Destination 10.

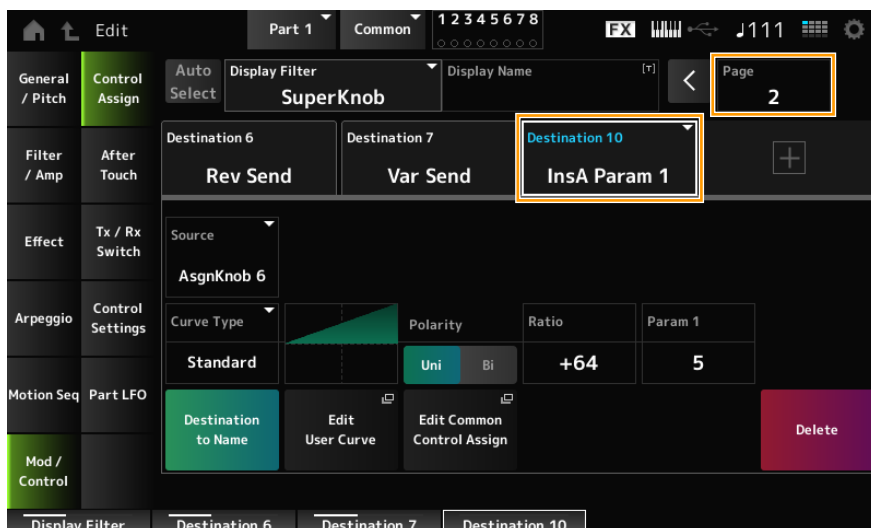

2-5. Tap the Destination 10 tab and select Volume from Part Param.

2-6. Set Polarity (Curve Polarity) to Bi and set Ratio (Curve Ratio) to +127.

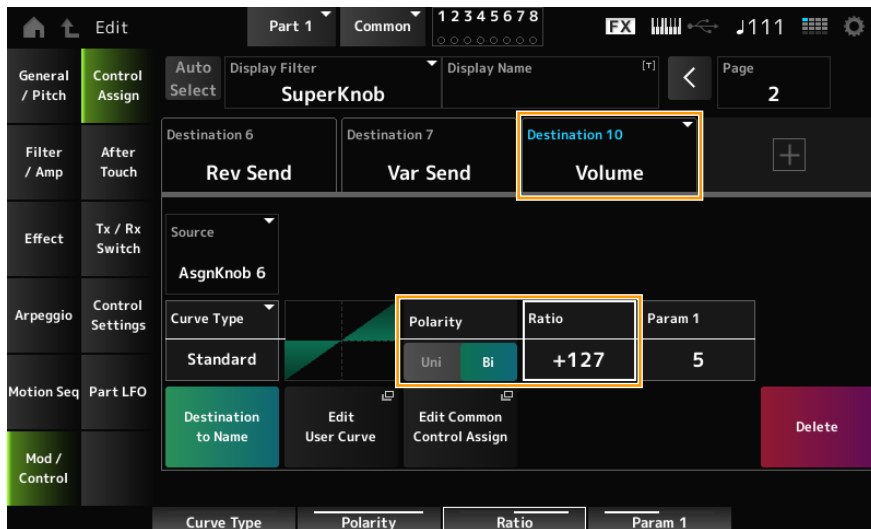

3. Set the parameters for Part 2.

3-1. Select Part 2.

3-2. Press the [CONTROL ASSIGN] button while holding down the [SHIFT] button and then turn the Super Knob. The Part 2 Control Assign screen will open.

3-3. Tap the [+] icon to add Destination 8.

3-4. Tap the Destination 8 tab and select Volume from Part Param.

3-5. Set Polarity (Curve Polarity) to Bi and set Ratio (Curve Ratio) to +127.

4. Set the parameters for Part 3.

4-1. Select Part 3.

4-2. Press the [CONTROL ASSIGN] button while holding down the [SHIFT] button and then turn the Super Knob. The Part 3 Control Assign screen will open.

4-3. Tap the [+] icon to add Destination 8.

4-4. Tap the Destination 8 tab and select Volume from Part Param.

4-5. Set Polarity (Curve Polarity) to Bi and set Ratio (Curve Ratio) to +127.

5. Check to make sure that the parameters for Parts 1 to 3 are set to Common Assignable Knob.

5-1. Press the [COMMON] button.

5-2. Press the [CONTROL ASSIGN] button while holding down the [SHIFT] button and then turn the Super Knob. The Common Control Assign screen will open.

5-3. Tap each of the Destination 6 to 8 tabs to check that the Source is set to AsgnKnob 6 to 8 respectively, and the Destination Parameter is set to Part 1 to 3 Volume.

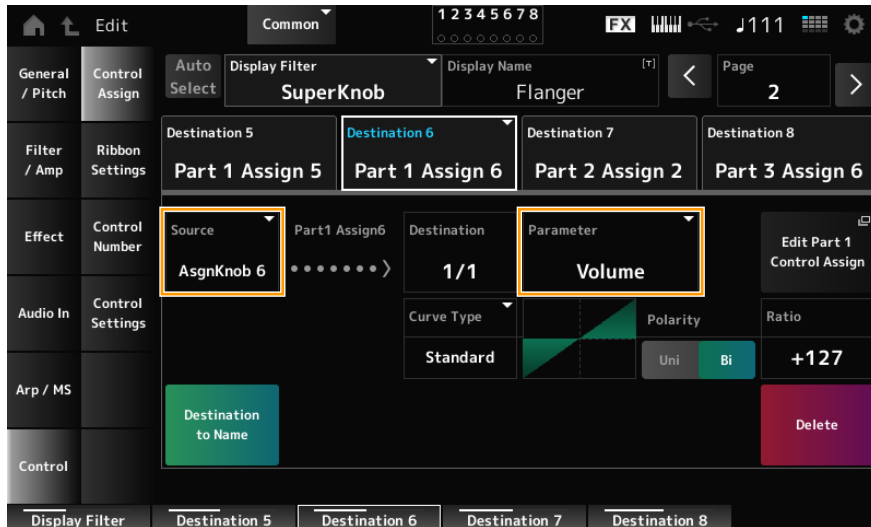

6. Set the LEFT position on the Super Knob.

This makes the settings for the Super Knob when turned all the way to the left.

6-1. Press the KNOB POSITION [LEFT] button.

6-2. Make sure that the COMMON is selected for Part select and then press the [ASSIGN] button. Make sure that the Knobs are set to 5 to 8.

6-3. To set only the CFX PopStudioGrand on Part 1 to sound, turn Knob 6 (Assign6) all the way to the right (to the maximum value) and Knob 7 (Assign7) and Knob 8 (Assign8) all the way to the left (to the minimum value).

6-4. Save the settings by simultaneously holding down the [SHIFT] button and pressing the KNOB POSITION [LEFT] button.

7. Set the RIGHT position on the Super Knob.

This makes the settings for the Super Knob when turned all the way to the right.

7-1. Press the KNOB POSITION [RIGHT] button.

7-2. To set only the TV Show FM EP on Part 3 to sound, turn Knob 8 (Assign8) all the way to the right (to the maximum value) and Knob 6 (Assign6) and Knob 7 (Assign7) all the way to the left (to the minimum value).

7-3. Save the settings by simultaneously holding down the [SHIFT] button and pressing the KNOB POSITION [RIGHT] button.

8. Set the MID position on the Super Knob.

Enable the MID position and then turn the Super Knob to set the value for the middle position.

- 8-1. Press the [NAVIGATION] button to open the NAVIGATION screen.
- 8-2. Tap on Super Knob and open the screen for the Super Knob settings.
- 8-3. Set the value 512 for the Mid Position.

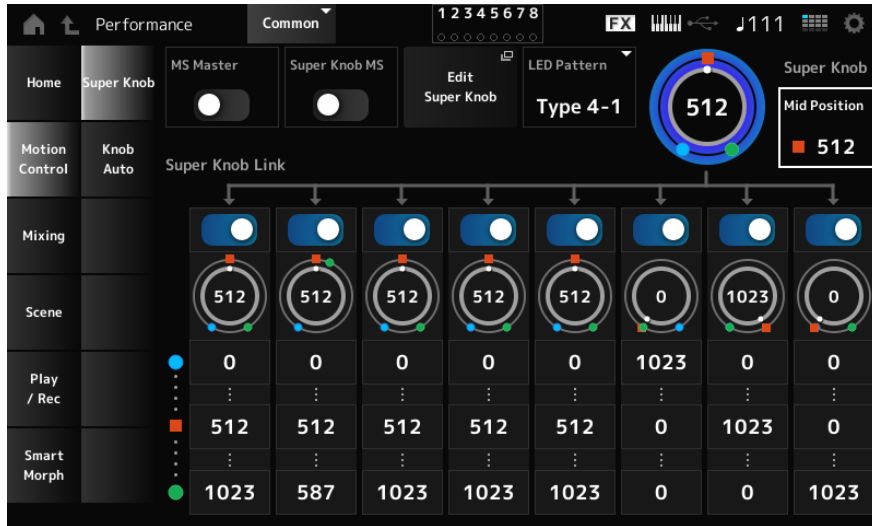

- 8-4. Press the KNOB POSITION [MID] button.
- 8-5. To set only the AN-X Sine Pad PAT on Part 2 to sound, turn Knob 7 (Assign7) all the way to the right (to the maximum value) and Knob 6 (Assign6) and Knob 8 (Assign8) all the way to the left (to the minimum value).
- 8-6. Save the settings by simultaneously holding down the [SHIFT] button and pressing the KNOB POSITION [MID] button.

The main setting is now complete.

9. Make fine adjustments.

Adjust the Curve Type, Ratio, and Param for each Part, and LEFT, RIGHT, and MID for the KNOB POSITION if desired.

Using Motion Sequencer

The Motion Sequencer function lets you create sound changes by controlling parameter times according to a sequence you create in advance. It allows you to set up rhythmical changes that are in sync with the Performance tempo, Arpeggio, or the rhythms input from the connecting device and to control such changes interactively and in real-time according to the progression of the song.

You can use up to four lanes in one Part, or up to eight lanes in an entire Performance. You can set up to eight sequence patterns per lane. As with Arpeggios, you can set the Velocity Limit and sequence playback method, the number of steps, etc. for playing back the sequence.

How to set the parameters for each lane:

[PERFORMANCE (HOME)] → Part selection → [EDIT/⟳] → Motion Seq → Lane

Turning Motion Sequencer on or off

To turn Motion Sequencer on or off, press the [MSEQ] button on the top panel.

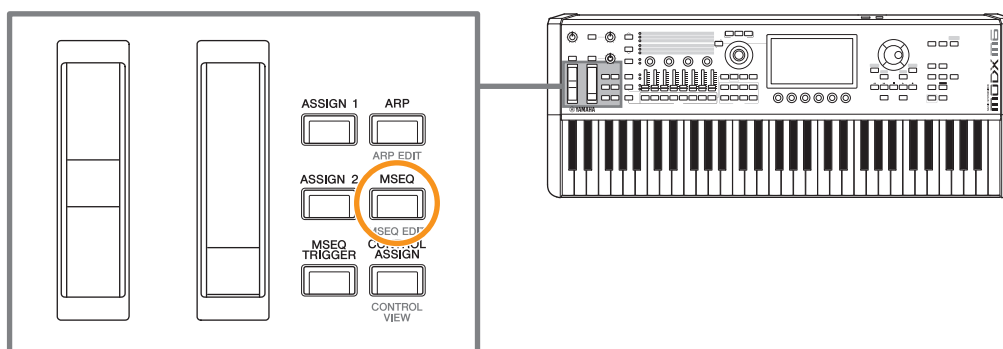

Changing Motion Sequencer by using the knobs

Select ARP/MSEQ with the [QUICK EDIT] button to use Knobs 3 and 4 to change Motion Sequencer. Modify the Motion Sequencer settings by turning the knobs and listening to the Motion Sequencer playback. For details on the effects of Knobs 3 and 4, refer to Arp/MS → MS Common on the Common Edit screen.

Changing the way Motion Sequence is triggered

The way Motion Sequencer is triggered can be set with the LaneSw and Trigger parameters.

LaneSw, Trigger

[PERFORMANCE (HOME)] → Part selection → [EDIT/⟳] → Motion Seq → Lane

Setting	Lane Sw	Trigger	Sync
Plays back the Motion Sequencer when you press a key	On	Off	-
Plays back the Motion Sequencer when you press the [MSEQ TRIGGER] button	On	On	Other than Arp

Editing the Motion Sequencer

Motion Sequence is comprised of up to 16 steps.

Tap Edit Sequence to open the Motion Sequence settings screen, and edit each step.

Using the Envelope Follower

Envelope Follower is the function that extracts the envelope of the waveform from the audio input and is used as a controller for creating changes in the sound. It allows the output of Parts and the output from the external device connected to the A/D INPUT jacks.

For example, you can use the Envelope Follower of one Part assigned a Rhythm Pattern as a source to add Variation to another Part. It is useful, for example, when you wish to set ducking (lowering the volume of a Part while a certain other Part is being played).

Each Envelope Follower has its own input source, such as EnvFollow 1 for Part 1, EnvFollow 2 for Part 2, and EnvFollow AD for the Audio Part. The output from each Envelope Follower can be changed by selecting a different Source from the Control Assign screen.

For example, you can set up the Envelope Follower for Part 1 (EnvFollow 1) to create changes in Part 2. How the sound is modified by the output from each Envelope follower can be set from the Control Assign screen.

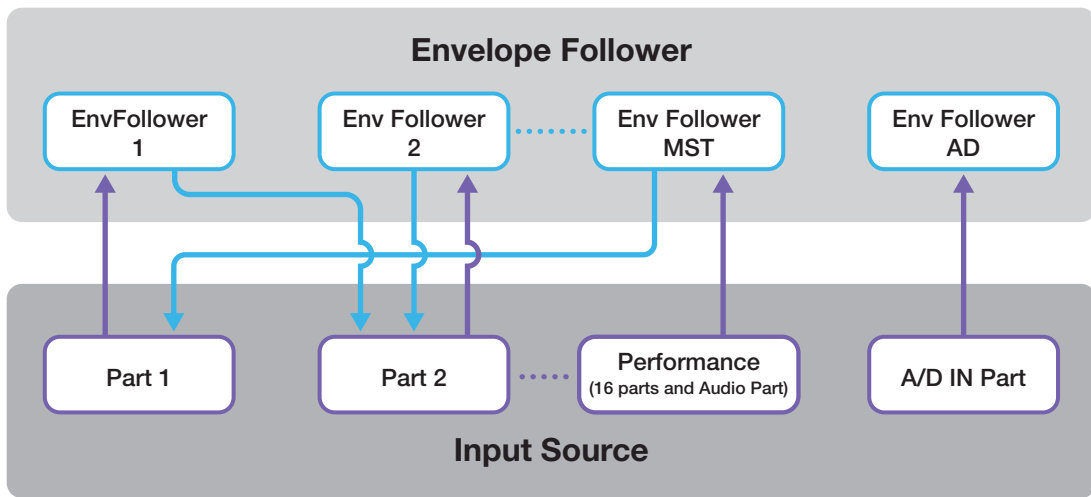

← (1) Input signal to Envelope Follower (Fixed)
 ← (2) Output signal from Envelope Follower (The Destination can be changed)

(1) Input signal to Envelope Follower

(2) Output signal from Envelope Follower

Settings for the Envelope Follower:

[PERFORMANCE (HOME)] → Common selection → [EDIT/⏏] → Effect → Routing → Envelope Follower (EnvFollow MST)

[PERFORMANCE (HOME)] → Common selection → [EDIT/⏏] → Audio In → Routing → Envelope Follower (EnvFollow AD)

[PERFORMANCE (HOME)] → Part selection → [EDIT/⏏] → Effect → Routing → Envelope Follower (EnvFollow 1–16)



Setting the Envelope Follower from the Rhythm Pattern screen

You can set the Envelope Follower on the Rhythm Pattern screen. This way, you can quickly access the Envelope Follower parameters often used for the Rhythm Patterns.

1. Press the [SONG/PATTERN] button while holding down the [SHIFT] button to open the Rhythm Pattern screen.

2. Select a drum sound from the list shown on the right side of the screen.

3. Tap Envelope Follower and turn the switch on.

You can play the keyboard to hear the effect of the Envelope Follower.

4. Adjust the settings.

Setting example

- Polarity (Curve Polarity): Bi
- Ratio (Curve Ratio): -63
- Gain (Envelope Follower Gain): -12.0 dB

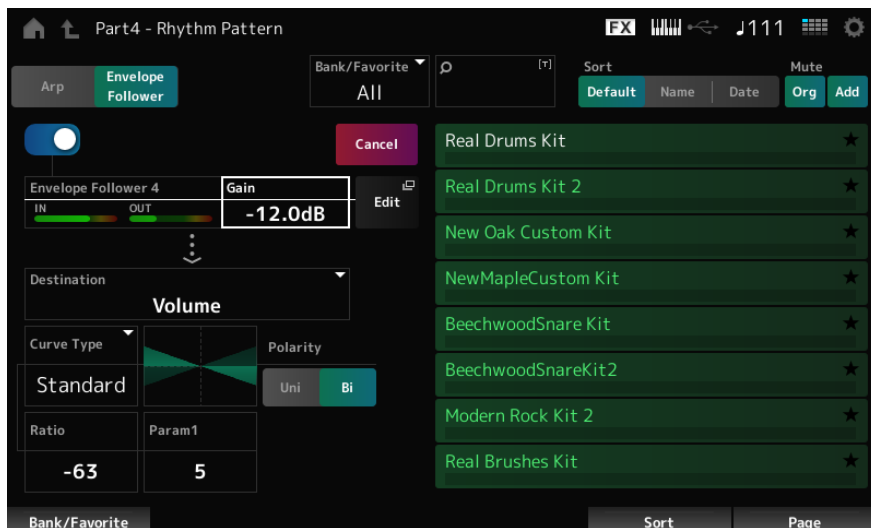

5. For finer adjustments, tap Edit on the screen.

The Envelope Follower Edit screen will open.

NOTE

- You can select a new kit or Arpeggio type for the Rhythm Pattern by simultaneously holding down the [SHIFT] button and pressing the [SONG/PATTERN] button to go back to the Rhythm Pattern screen.
- The Envelope Follower settings are retained after selecting a new kit or Arpeggio for the Rhythm Pattern.

Using Smart Morph

Smart Morph is a function that morphs FM-X Parts or AN-X Parts using machine learning. This allows you to create a new sound for Part 1 from multiple FM-X Parts or AN-X Parts to play on the keyboard.

Features of Smart Morph

The Smart Morph function analyzes each sound assigned to Parts 9 to 16 and plots one dot per Part on the map. Each dot on the map represents a sound, and the distance between dots shows the similarities of these sounds.

Creating a new part (Learn)

The Learn feature automatically generates sounds to fill in the gaps between dots on the map. When you tap the dot on the map, the sound for that dot will be selected for Part 1. You can find a new place you like from the map and save its settings to create a new part.

By dragging the dot on the map while playing the keyboard, or by moving the Super Knob with the movements of two to eight dots assigned beforehand, you can create completely new sounds.

Saving edited settings

After editing, save the Performance you have created in the internal memory. Saving the settings to internal memory is referred to as the “Store” operation.

NOTICE

- When you select a different Performance or turn off the instrument without first storing the Performance, you will lose the settings you are editing.
- The existing Performances on the User Bank will be lost when you overwrite them. When you save Performances you have edited, make sure not to overwrite existing Performances. Important settings you’ve made should be saved to a USB flash drive (Save). For the Save operation, see “Saving settings to a USB flash drive as a backup file (Save).”

How to store a Performance

1. Press the [STORE] button.

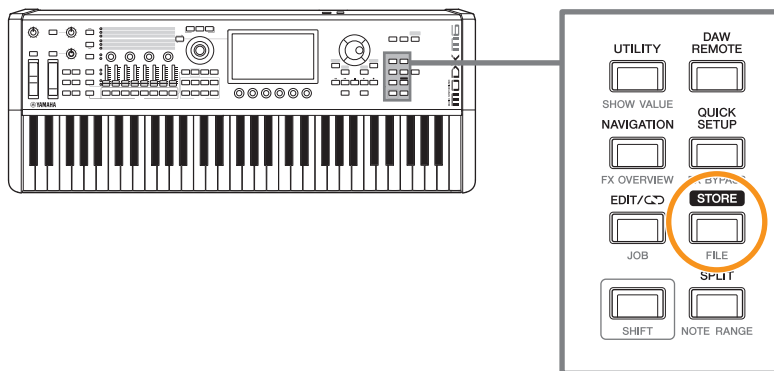

- If you are saving a new Performance, Store As New Performance will be displayed.
- If the Performance has already been stored, Overwrite Current Perf. and Store As New Performance will be displayed.

2. To store as a new Performance, tap Store As New Performance.

If you want to overwrite a Performance that has already been stored, tap Overwrite Current Perf. and then tap Store (YES).

3. Type in the Performance name on the Keyboard screen.

Use the keyboard shown on the Main display. You can use up to 20 alphanumeric characters.

4. Tap Done when you have finished entering the name.

When the Store operation is complete, the Performance screen will be shown on the display.

Creating a Live Set

The Live Set function is a convenient way to change among different Performances as you play songs on a setlist, for example.

On this instrument, you can create a Live Set simply by registering your favorite Performance to each slot.

Registering a Performance to the slot

You can register a Performance to the Live Set by following the procedure below.

NOTICE

- Store the Performance you have just edited before registering the Performance to the Live Set. However, when you register to the Live Set and select Store As New Perf. and Register or Overwrite Current Perf. and Register, you do not need to store the Performance in advance.
- When you select a different Performance or turn off the instrument without first storing the Performance, you will lose the edited settings you have made.

1. Select a Performance from the Performance screen.

Make sure the [LIVE SET] button is lit or semi-lit.

2. Simultaneously hold down the [SHIFT] button and press the [LIVE SET] button.

The Live Set Register screen appears.

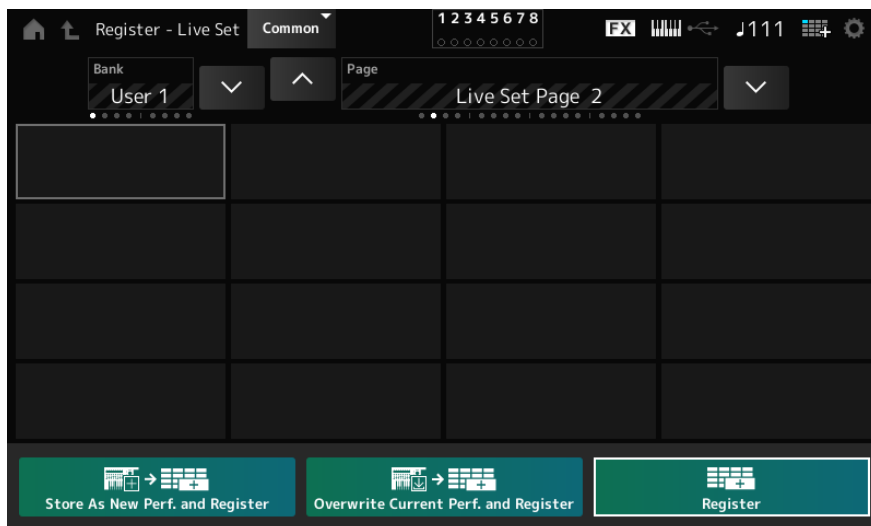

3. Tap the slot you want to register to select it.

4. Select one of the available store operations and press the [ENTER] button, or simply tap your selection on the screen.

Storage method	Description
Store As New Perf. and Register	Stores as a new Performance and registers
Overwrite Current Perf. and Register	Overwrites the current Performance and registers
Register	Registers

Change the Performance name as needed. Confirm the changes to register the Performance in the slot.

NOTE

If you want to register a new Performance before an already registered slot, follow the steps below.

1. Simultaneously hold down the [SHIFT] button and tap the slot. A cursor will appear in front of the slot.
2. While holding down the [SHIFT] button, select the storage method and press the [ENTER] button or tap the screen. At this time, the Performance registered in the last slot (bottom right) of the Live Set page will be deleted.

Exchanging Performances registered to slots

You can exchange the contents of slots.

1. Open the screen from: [LIVE SET] (or Live Set icon) → User Bank selection → [EDIT/↔].

The Live Set Edit screen appears.

When the Live Set page on the Preset bank or the Library bank is open, the Live Set Edit screen will not appear.

2. Tap Job on the screen.

The Jobscreen will appear at the bottom of the screen.

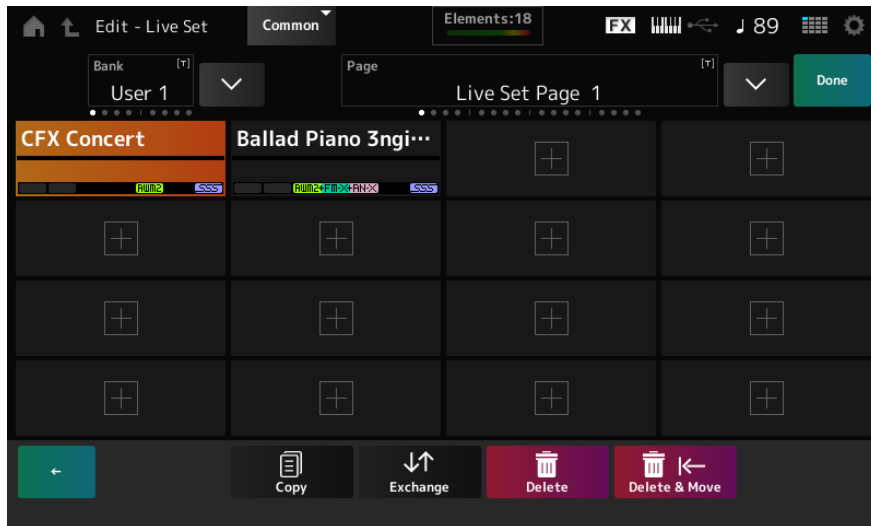

3. Tap the slot you wish to move the Performance from, and then tap Exchange.

The Jobscreen will appear at the bottom of the screen.

4. Tap the slot you wish to move the Performance to.

The Performances of the two slots will be exchanged.

5. Once the exchange is complete, tap Done.

NOTE

If you wish to copy or exchange the entire Bank or the entire Page, with the Live Set screen displayed, simultaneously hold down the [SHIFT] button and press the [EDIT/↔] button. Then the dialog box will appear.

Registering a Pattern, Song, or Audio file to the slot

You can also add Patterns, Songs, or Audio files to Live Set slots. This way, you can select a slot for playing back a desired Pattern, Song, or Audio file, and then play the Performance on the keyboard along with it.

1. Open the screen from: [LIVE SET] (or Live Set icon) → User Bank selection → [EDIT/↶].

The Live Set Edit screen appears.

When the Live Set page on the Preset bank or the Library bank is open, the Live Set Edit screen will not appear.

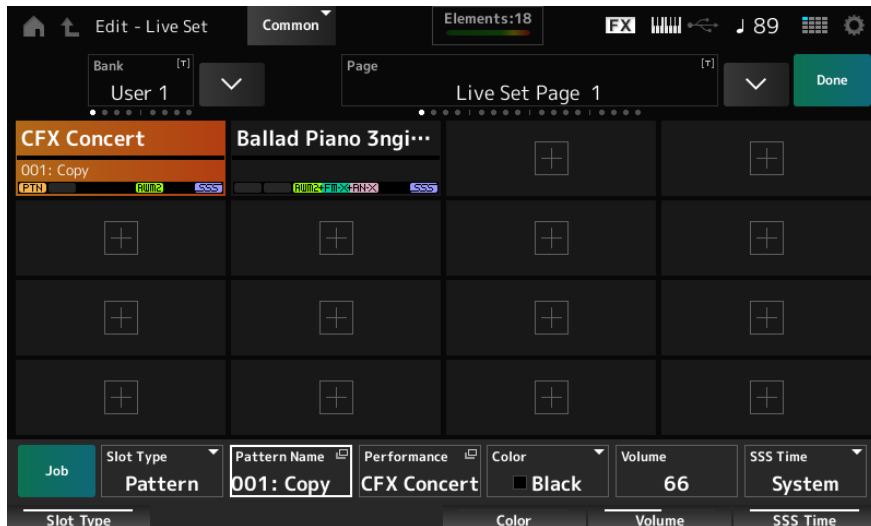

2. Select a slot or tap [+] on the screen.

3. Select the slot you want to register from Slot Type.

Slot Type	Type
Perform	Performance
Song	Songs
Audio	Audio file
Pattern	Patterns

4. Tap Pattern Name, Audio Name, etc. to open the Load screen.

5. Select the desired pattern or file to register to the slot.

6. Once the settings are complete, tap Done.

NOTE

You can also register a Pattern or Song to the Live Set by pressing the [SHIFT] and [LIVE SET] buttons on the Pattern screen or Song screen.

Exchanging slots with the foot switch

You can select a different Live Set slot by using a separately sold foot switch, such as the FC4A or FC5. Follow the procedure below.

1. Connect a foot switch (FC4A or FC5) to the FOOT SWITCH [ASSIGNABLE] jack.

2. Open the screen as follows: [UTILITY] → Settings → MIDI I/O.

The MIDI I/O screen appears.

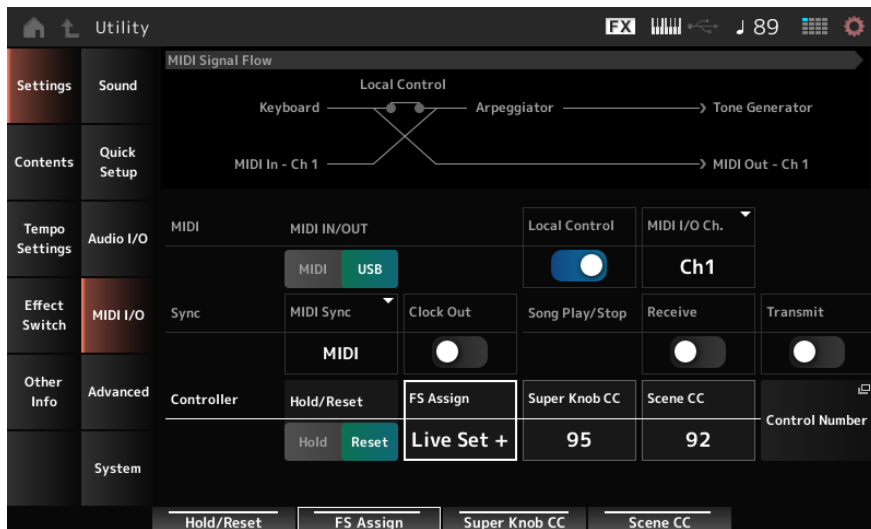

3. Set FS Assign to either Live Set+ or Live Set-.

With Live Set+, you can select the next Live Set slot in forward order.

With Live Set-, you can select the next Live Set slot in reverse order.

Selecting Performances from a Live Set

Select Performances for a setlist from the Live Set screen.

1. Press the [LIVE SET] button to open the screen.

The Live Set screen appears.

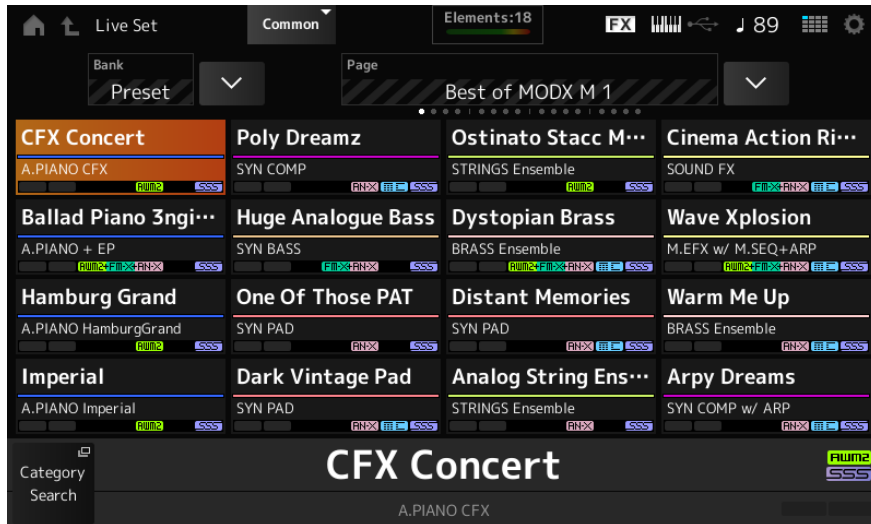

2. Switch between Bank and Page as needed.

3. Tap a slot to select it.

The Performance for the setlist will be selected.

Playing the keyboard

Make sure to select a Performance from the Live Set before playing the keyboard.

If desired, you can also play back a specific Pattern, Song, or Audio file (registered to a Live Set slot) along with your keyboard performance.

Playing back a Pattern, Song, or Audio file registered to a Live Set slot

You can play the keyboard along with the Pattern, Song, or Audio file registered to the slot.

NOTE

While the Song or Pattern is being played back, you cannot change the Performance or select a different slot. If you attempt to change them, an error message will appear.

1. Select a slot on the Live Set screen.

2. Press the [▶] (Play) button.

The Pattern, Song, or Audio file registered to the selected slot will then play back.

NOTE

While the Pattern, Song, or Audio file is played back, pressing the [▶] (Play) button shows the same screen as the Pattern screen, Song screen, or Audio screen.

3. Press the [■] (Stop) button to stop playback.

3. Recording and Playback

You can use this instrument to record and play back Patterns, Songs, and Audio files.

Patterns and Songs are recorded in the storage area within the instrument, while Audio files are recorded to a connected USB flash drive.

Terminology

Patterns

Patterns are comprised of MIDI sequence data, containing short phrases recorded as MIDI events. They can be played back in a loop or used with the Scene function. This instrument can hold up to 128 Patterns within the memory area.

Songs

Songs are comprised of MIDI sequence data, containing information on the operation of the keyboard and other controllers recorded as MIDI events. This instrument can hold up to 128 Songs within the memory area.

Tracks

Tracks are separate storage locations for recording the keyboard performance. A track holds the information for one Part. A maximum of 16 tracks are available on this instrument, so you can use up to 16 Parts for recording and playing back.

Recording and playing back patterns

Record a melody on a track.

Recording a Pattern

1. Select the desired sound for recording on Track 1.
2. Press the [SONG/PATTERN] button and tap Pattern.

The Pattern screen appears.

NOTE

You can also open the same screen from the [PERFORMANCE (HOME)] button → Play/Rec → Pattern.

3. Change the scene length (Length), tempo (Tempo), and other settings as needed.
4. Press one of the [SCENE] buttons to select the desired Scene for recording.
5. Press the [●] (Record) button.

Recording will be set to standby.

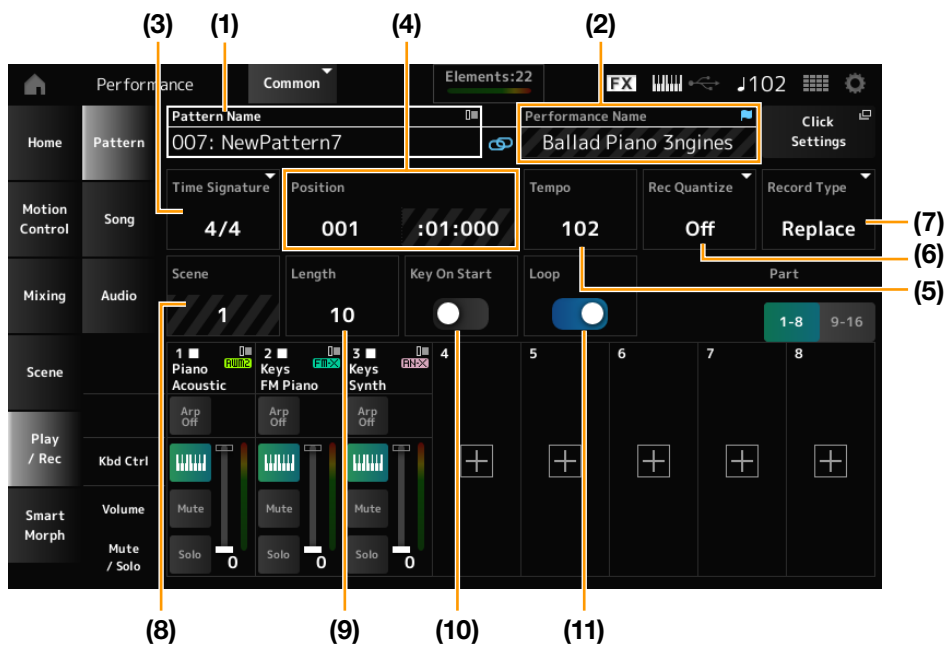

- | | |
|--|--|
| (1) Pattern name | (8) Scene |
| (2) Name of the Performance currently selected | (9) Length of the pattern |
| (3) Time signature | (10) Turning on or off the function to start recording at key-on |
| (4) Position for starting playback and recording | (11) Turning the loop setting on or off |
| (5) Tempo | |
| (6) Quantize | |
| (7) Switching recording types (not shown when recording a new pattern) | |

6. Press the [▶] (Play) button to start recording.

7. Play the keyboard.

When Loop is on, the phrase you play while recording will be played back in a loop, allowing you to record it onto another track while maintaining the recording status.

NOTE

When you press the [●] (Record) button during recording, it will flash and Rehearsal mode is enabled. In this mode, you can temporarily disable recording on a track while continuing to play back. This is useful when you want to try out a sound. Pressing the [●] (Record) button again while in Rehearsal mode will return you to Recording mode.

8. Select the desired sound for Track 2, and play the keyboard along with the phrase you recorded on Track 1.

9. Record other tracks as needed.

Songs and Patterns are stored automatically when recorded.

If you want to change the tempo or tone of a song or pattern after recording and then store it, tap Store Pattern&Perf Settings (or Store Song&Perf Settings for a song) to store it.

NOTE

If you have edited the Performance parameters, you will also need to store the Performance.

Canceling the last recording action (Undo, Redo)

Undo cancels the last recording action and deletes what has been just recorded.

Redo restores the recording that has been canceled by Undo.

Undo Media Record (does not appear when there are no recordings)

Tapping this cancels the last recording action and restores the recording to its original state.



Redo Media Record (does not appear until Undo has been done)

Tapping this restores the recording to its state before Undo.

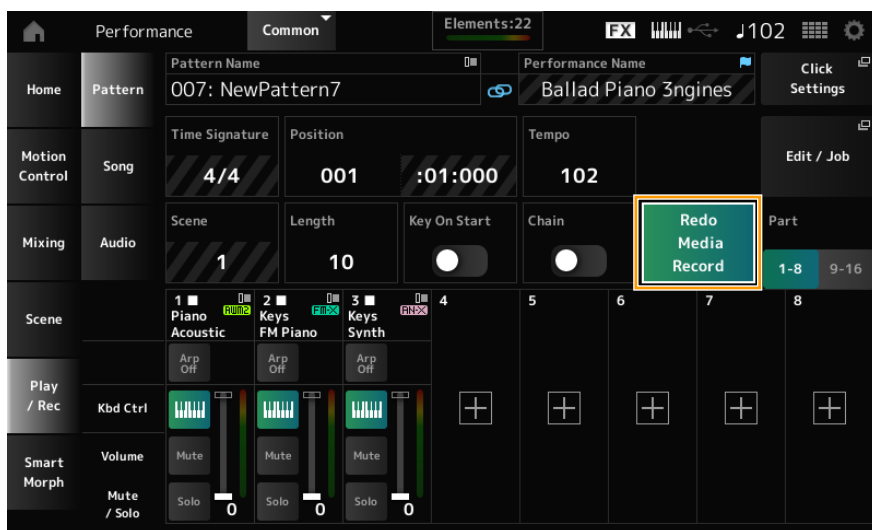

Playing back the Pattern

To play back the recorded Pattern, use the Sequencer Transport buttons.

You can use the SCENE buttons to select a Scene for playback.

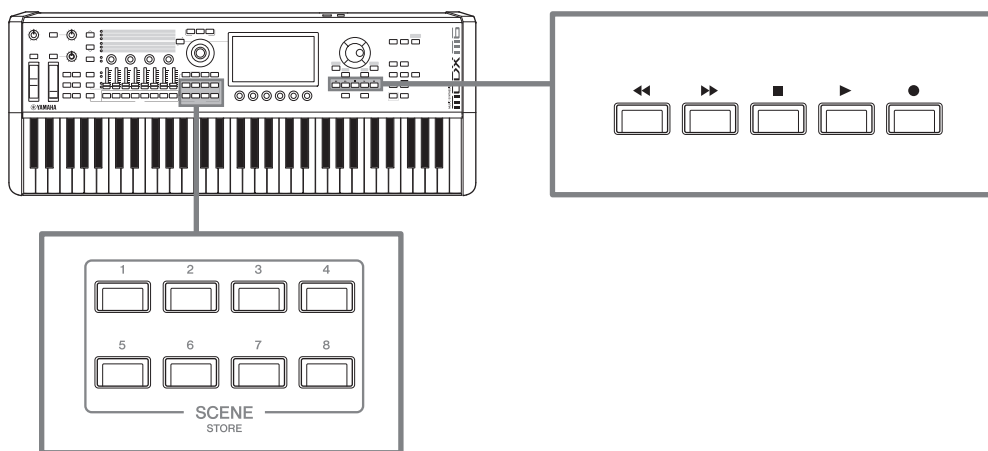

Recording and playing back songs

Recording a Song

Not only the keyboard performance, but also the operations of the controllers and knobs are recorded to a track as MIDI data.

When you play the keyboard or operate a controller, the parts with the Keyboard Control Switch On will be recorded. For the knob operations, Control Change and Parameter Change messages will also be recorded. For more information on Control Change, refer to the Data List.

NOTE

- When Arp Rec is On, only the result of the Arpeggio playback is recorded.
- When Arp Rec is Off, data of the entire keyboard performance is recorded, enabling you to change the Arpeggio patterns later.

1. Select a Performance.

2. Press the [SONG/PATTERN] button to open the Play/Rec screen and select the Song tab, and then press the [●] (Record) button.

The [●] (Record) button flashes, and recording is set to standby.

NOTE

Recording can also be set to standby by opening the screen from: [PERFORMANCE (HOME)] → Play/Rec → Song and pressing the [●] (Record) button.

3. Change the Time Signature and Rec Quantize as needed.

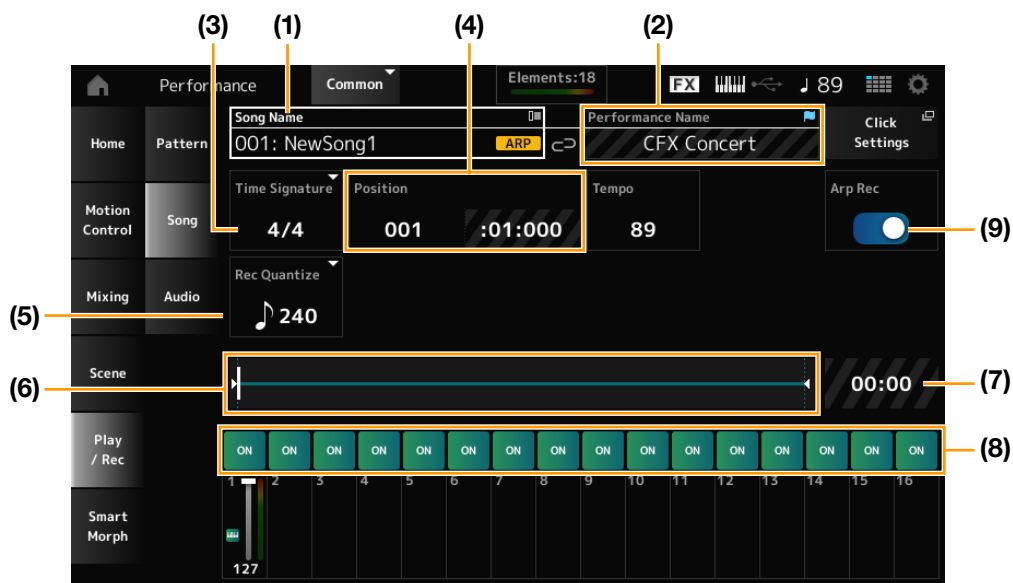

(1) Song name

(2) Name of the Performance currently selected

(3) Time signature

(4) Position for starting playback and recording

(5) Quantize

(6) The total length of the sequence and the current position for playback

(7) Time for the entire sequence

(8) Setting the track on or off for playback

(9) Turning Arpeggio recording on or off (only for a new recording)

4. When the preparation is complete, press the [▶] (Play) button to start recording.

If the Click Settings is set, the Precount starts when you press the [▶] (Play) button. Start playing the keyboard after the precount.

5. When the keyboard performance is finished, press the [■] (Stop) button to stop recording.

Recording some parts again (Punch-in / Punch-out recording)

There are three types of recording (Record Type) available on this instrument: Replace, Overdub, and Punch.

- **Replace:** overwrites the existing data.
- **Overdub:** adds a layer to the existing sound on the track.
- **Punch:** overwrites the specified section of the existing data.

If you wish to rerecord a specified section, you can set up the Punch-in / Punch-out parameters for the Punch recording. When you start the Punch recording, the recorded Song will be played back from the beginning. When the playback reaches the measure set for Punch-in, the recording starts automatically. The recording ends automatically when it reaches the measure set for Punch-out, and the rest of the recorded Song will be played back to the end. For example, if you wish to rerecord measures 3 to 5 of an eight-measure Song, follow the instructions shown below.

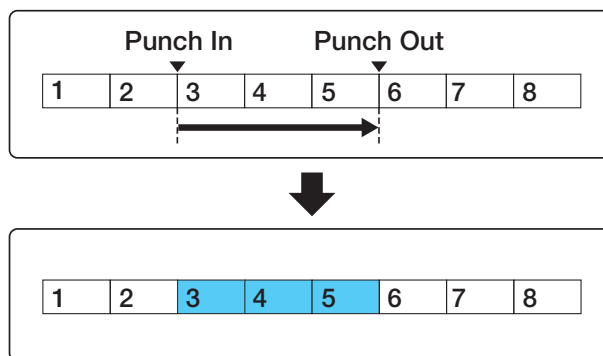

For the above Punch-in / Punch-out recording, set up the following parameters in the Record Setup screen.

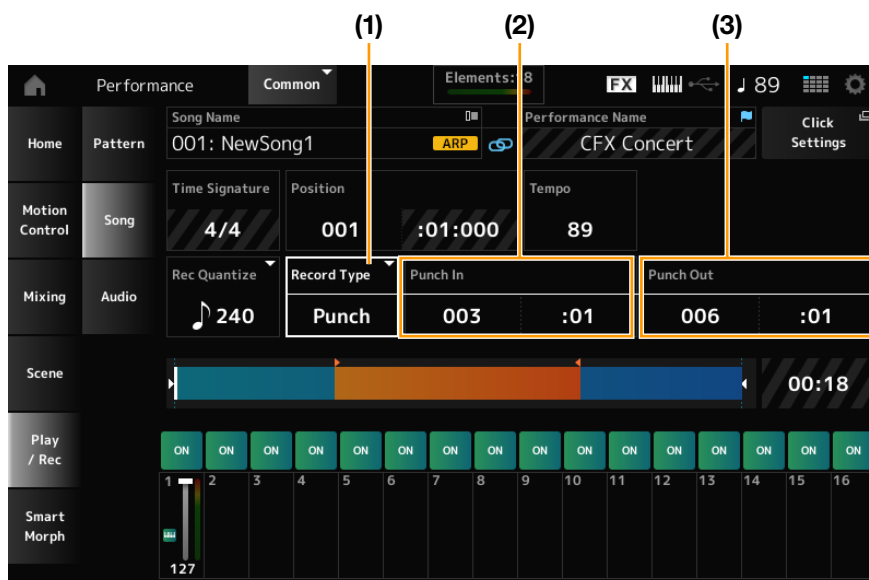

(1) Record Type = Punch

(2) Punch In (Measure and beat to start rerecording) = 003:01

Starting from the measure and beat specified here, the sound of the corresponding track will be turned off and your keyboard performance will be recorded.

(3) Punch Out (Measure and beat to end rerecording) = 006:01

Starting from the measure and beat specified here, the track will be played back.

Canceling the last recording action (Undo, Redo)

Undo cancels the last recording action and deletes what has been just recorded.

Redo restores the recording that has been canceled by Undo.

Undo Media Record (does not appear when there are no recordings)

Tap to see the confirmation screen. Continue(YES) cancels the last recording action and restores the recorder to its original state.

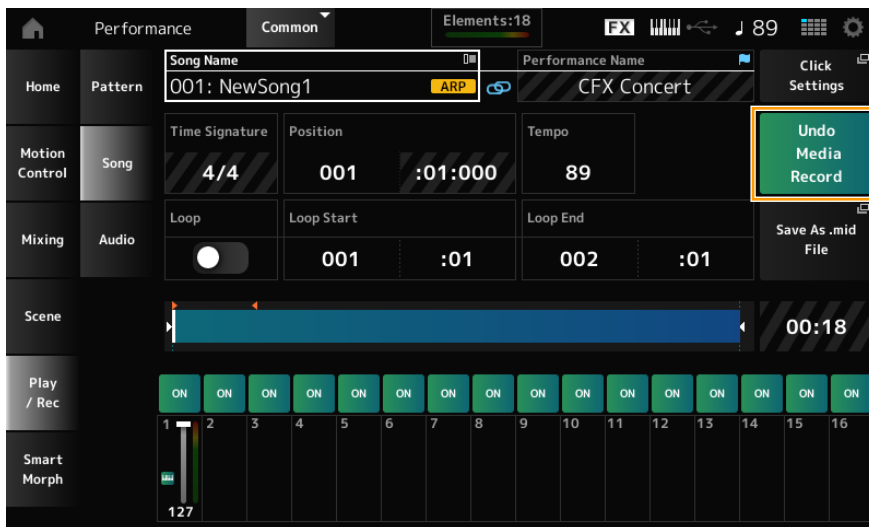

Redo Media Record (does not appear until Undo has been done)

Tap to see the confirmation screen. Continue(YES) restores the recording to its state before Undo.

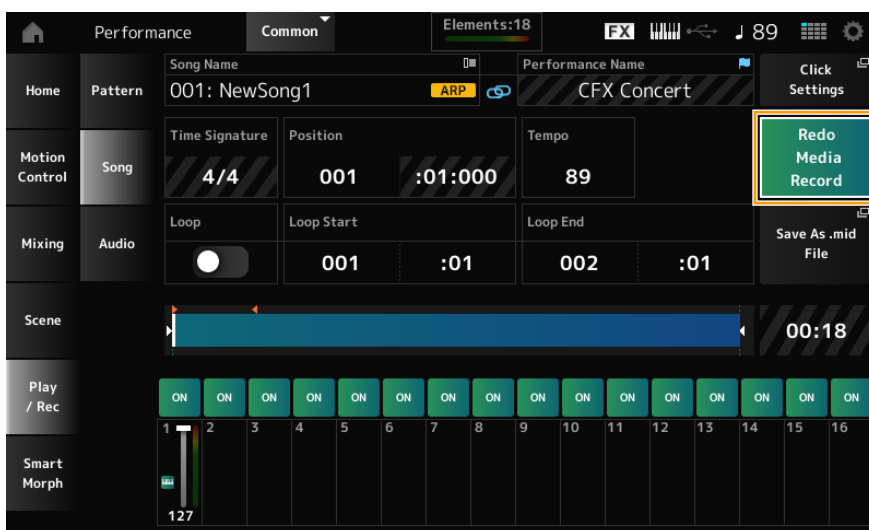

Playing back the Song

To check the recorded Song, use the Sequencer Transport buttons.

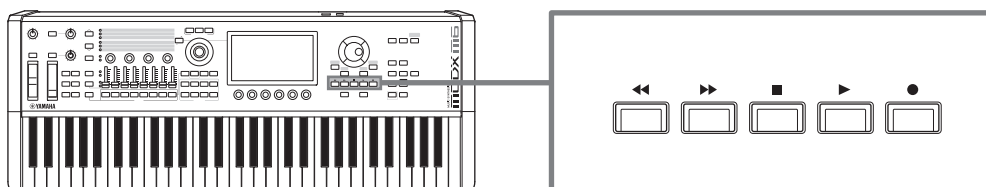

Recording audio and playing back audio files

Recording audio

You can use this instrument to record and playback Audio files in stereo (44.1 kHz, 24-bit wav). The recording level is fixed, and it is possible to record continuously for up to 74 minutes (assuming that the USB storage device has sufficient free memory).

1. Connect a USB flash drive to the USB [TO DEVICE] terminal of the instrument.

2. Opens the screen from: [PERFORMANCE (HOME)] → Play/Rec → Audio.

The audio recording screen appears.

3. Press the [●] (Record) button.

The [●] (Record) button flashes, and recording is set to standby.



(1) Position for recording

(2) The total length of the audio file and the current position for recording

(3) Available recording time

(4) Level meter

(5) Trigger Level

4. Sets the Trigger Level.

If you set the Trigger Level to manual, recording will begin whenever you press the [▶] (Play) button.

Alternatively, if you set the Trigger Level to a value between 1 and 127, recording will begin automatically after you have pressed the [▶] (Play) button and then whenever playback volume exceeds that level.

The set Trigger Level will be indicated by a blue line in the level meter (4). For best results, set this parameter as low as possible to capture the entire signal, but not so low as to record unwanted noise.

5. Press the [▶] (Play) button.

If you have set the Trigger Level to manual, recording will begin immediately right after you press the [▶] (Play) button. While recording, the [●] (Record) button will light in red, and the [▶] (Play) button will light in green.

If you have set a value between 1 and 127 as the Trigger Level, the recording will begin automatically whenever the playback volume exceeds that level.

6. Play the keyboard.
7. When you have finished playing, press the [■] (Stop) button.
The recorded audio file will be saved to the USB flash drive.

Playing an audio file

As described below, this instrument can play audio files (44.1 kHz, 24-bit or 16-bit .wav in stereo) from a USB flash drive. You can also play a Performance on the keyboard while playing back the audio file.

1. Connect a USB flash drive to the USB [TO DEVICE] terminal of the instrument.
2. Opens the screen from: [PERFORMANCE (HOME)] → Play/Rec → Audio.
3. Tap Audio Name (1), then tap Load in the context menu.
4. Select the desired source USB flash drive and folder that contains the settings.
5. Select the desired .wav file on the USB flash drive to load.

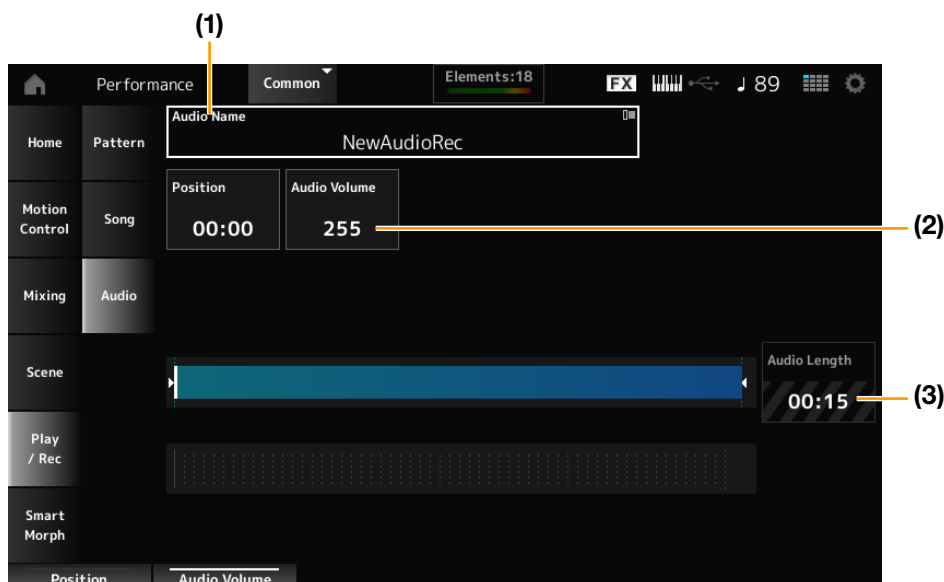

- (1) Audio name
- (2) Volume for playback
- (3) Audio length

6. Press the [▶] (Play) button.
The audio file will play back.
7. Move the cursor to Audio Volume (2), and then adjust the playback volume by using the Data dial.
8. Press the [■] (Stop) button to stop playback.

4. Managing Back Ups

You can save backups of the Performances, Live sets, and the Utility settings you have created and saved (stored) on the instrument to a USB flash drive, as well as load settings from backup files from the USB flash drive to this instrument.

This section covers how to save all settings in the User memory to a USB flash drive and how to load your settings back to the instrument.

The performance settings created on this device can also be backed up using Soundmondo (a sound management and sharing service).

Soundmondo: <https://www.yamaha.com/2/soundmondo>

Available file formats

Saving to USB flash drive

Formats common to MONTAGE M and MODX M

- Backup file (.Y2A)
Everything in User memory (including the User area, Library area, Songs, and Patterns)
- User files (.Y2U)
Everything in the User area of User memory (including the Utility settings and Quick Setups)
- Library files (.Y2L)
User area in User memory (Excluding utility settings and quick setup. Live Set is 1 bank only)

If the file size is larger than approximately 2 GB, the file will be divided in two. Split files will have different file extensions.

- Backup files (.Y2B)
- User files (.Y2W)
- Library files (.Y2M)

Generic file formats

- Patterns and Songs (.MID)
Patterns and Songs saved to User memory

Loading from a USB flash drive

Files saved on the MONTAGE M and MODX M (.Y2A, .Y2U, .Y2L, .MID)

Generic file formats

- Audio files (.WAV and .AIF)
Files used as User Waveforms
- MIDI files (.MID)
Files used as Patterns and Songs

File formats used for older models

- MONTAGE (.X7A, .X7U, .X7L)
- MODX, MODX+ (.X8A, .X8U, .X8L)
- MOTIF XF (.X3A, .X3V, .X3G, .X3W)
- MOTIF XS (.X0A, .X0V, .X0G, .X0W)
- MOXF (.X6A, .X6V, .X6G, .X6W)

NOTE

If the backup file saved on the MONTAGE M exceeds the capacity of the MODX M's user waveform memory, that file cannot be loaded.

The USB flash drive will be formatted.

We recommend formatting the USB flash drive on the instrument. USB flash drives formatted on other devices may not work properly with this instrument.

NOTICE

Formatting a USB flash drive will erase all data stored on it. Please make sure that there is no necessary data on the card before formatting.

Formatting Procedure

1. Connect a USB flash drive to the USB [TO DEVICE] terminal of the instrument.
2. Open the screen by going to [UTILITY] → Contents → Load.
You can open the same screen by simultaneously holding down the [SHIFT] button and pressing the [STORE] button.
3. Tap Job in the upper right corner of the screen, then tap the connected USB flash drive.

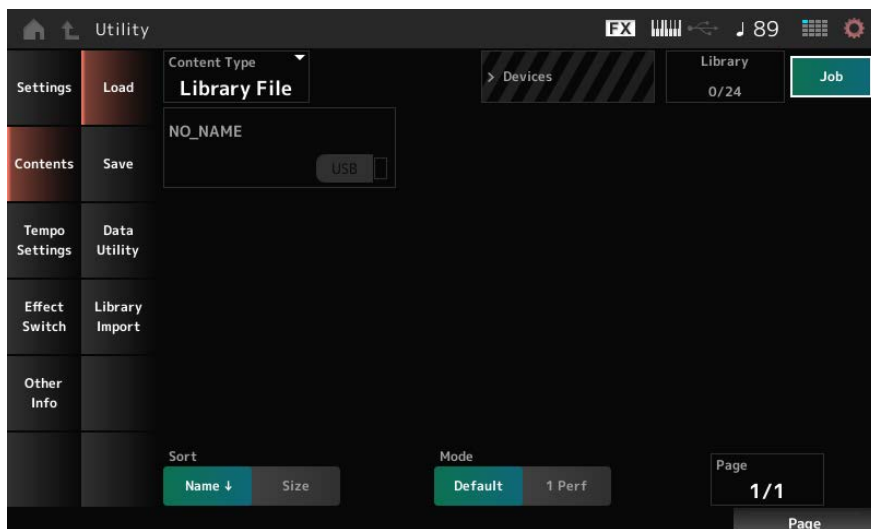

4. Tap Format in the context menu.

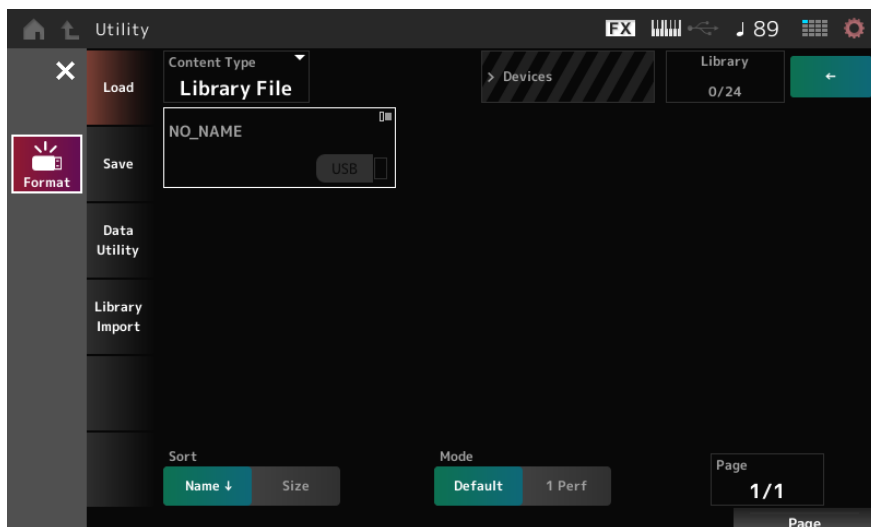

5. Tap Format(YES).
Formatting is complete.

Saving settings to a USB flash drive

1. Connect a USB flash drive to the USB [TO DEVICE] terminal of the instrument.
2. Open the screen by going to [UTILITY] → Contents → Save.
You can open the same screen by simultaneously holding down the [SHIFT] button and pressing the [STORE] button, and then selecting the Save tab.
3. Under Content Type, select Backup File.

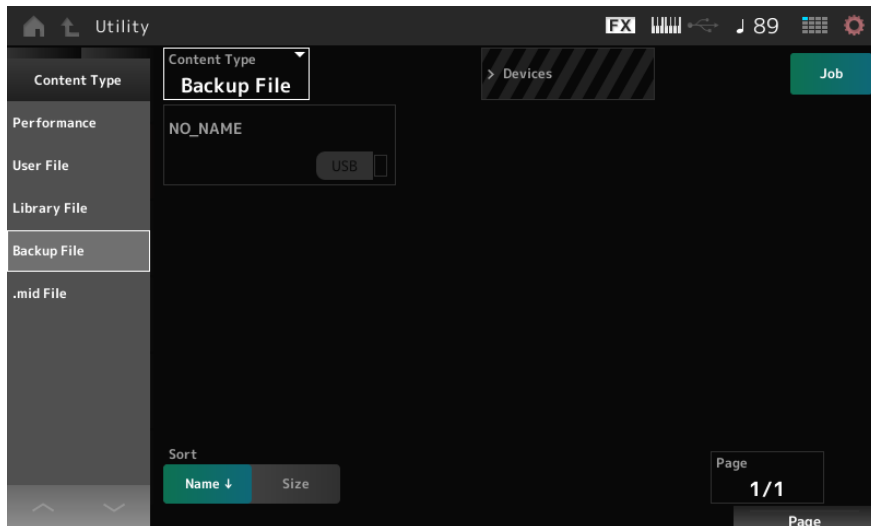

4. Select the USB flash drive and desired folder for saving the file.

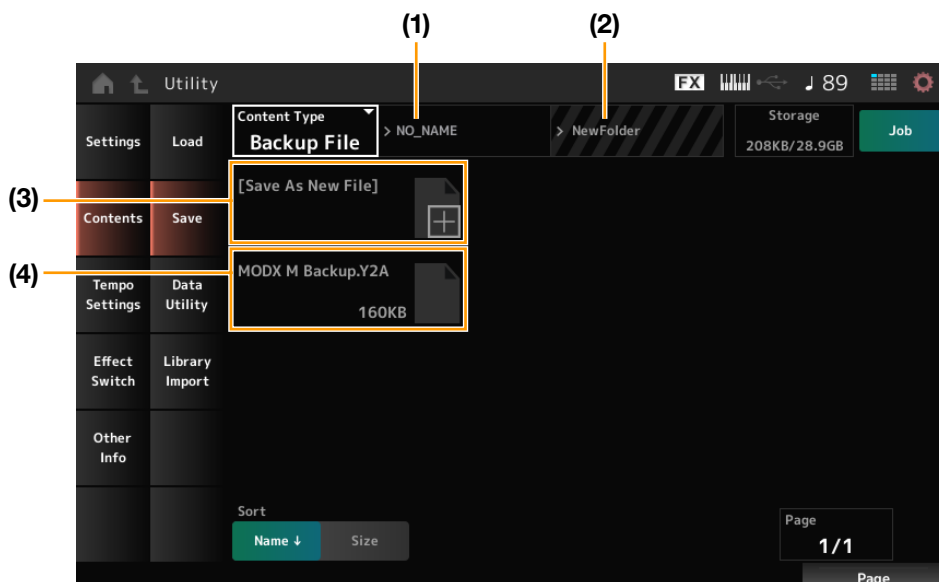

- (1) Parent folder name
- (2) Name of the destination folder currently selected in the USB flash drive
- (3) Save to
- (4) List of files already saved in the folder

5. Tap [+] for Save As New File.

This calls up the screen for entering names.

NOTE

To overwrite the existing file, confirm the process by tapping the file name on the screen. Tap Save(YES) to save the file.

6. Enter the file name you wish to use.

For specific information on how to enter file names, refer to the Quick Guide.

7. Tap Done to finish entering the name.

The backup file will then be saved to the USB flash drive.

Loading settings from a USB flash drive

NOTICE

When settings are loaded, the existing settings on the instrument will be overwritten and lost. Important settings you want to keep should be saved to a USB flash drive (Save) before loading the settings.

1. Connect a USB flash drive to the USB [TO DEVICE] terminal of the instrument.
2. Open the screen by going to [UTILITY] → Contents → Load.
You can open the same screen by simultaneously holding down the [SHIFT] button and pressing the [STORE] button.
3. Under Content Type, select Backup File.
4. Select the desired source USB flash drive and folder that contains the settings.
5. Select the desired file on the USB flash drive to load.

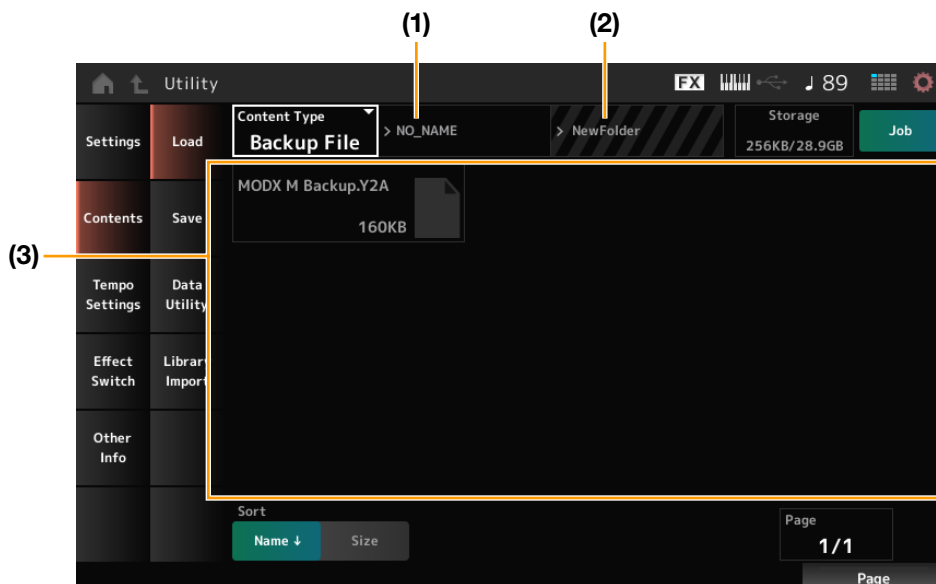

- (1) Parent folder name
- (2) Name of desired folder currently selected in the USB flash drive
- (3) List of files already saved in the folder

5. Connecting external MIDI instruments

Connecting a microphone or audio device

This device allows you to connect audio devices such as microphones and CD players, as well as electronic musical instruments such as synthesizers, to the A/D INPUT terminal and play the input audio as an audio input part (A/D INPUT part).

As with other parts, you can set Volume, Pan, Effects, etc. The audio input part is mixed with other parts and output as the sound of this instrument.

Connecting microphones and audio devices

1. Make sure to turn off this instrument and set the A/D INPUT [GAIN] knob to the minimum value.
2. Connect the external device to the A/D INPUT jack(s) on the rear panel.

■ When connecting a microphone

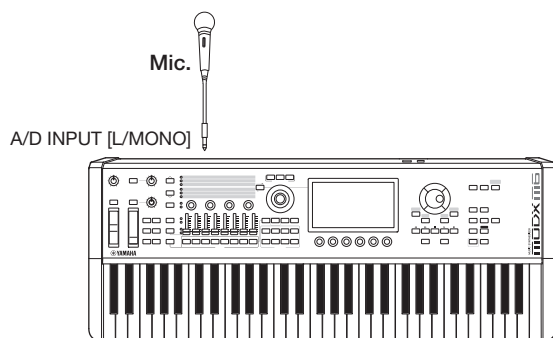

NOTE

Make sure to use a dynamic microphone. Condenser microphones cannot be used.

■ When connecting audio devices, electronic musical instruments, etc.

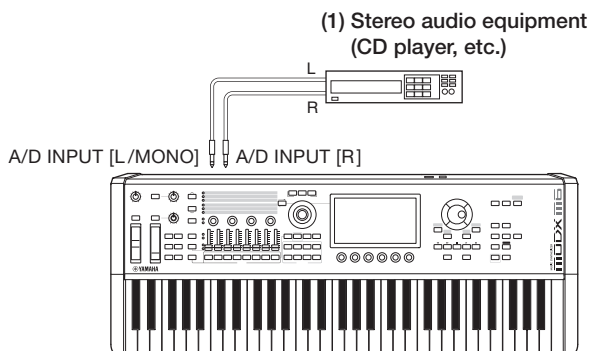

(1) Stereo audio device (CD player, etc.)

3. Turn on the connected device, and then turn on this instrument.
4. Open the screen by going to [UTILITY] → Settings → Audio I/O.

5. Select the A/D Input setting for the device connected to the A/D INPUT jack(s).

Set to Mic when a microphone or any device with a low output level is connected. Set to Line when an audio device, electronic instrument, or any device with a high input level is connected.

6. Press the [A/D INPUT] button.

The button lights up and the input from the audio equipment connected to this instrument is enabled.

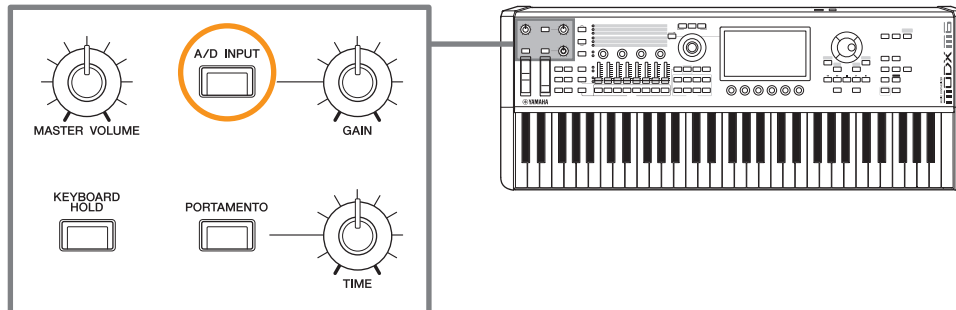

7. Listen to the sound from the external device connected to the MODX M and turn the A/D INPUT [GAIN] knob to adjust the gain.

8. Press the [PERFORMANCE (HOME)] button and select the Performance you wish to use with the external device connected to the MODX M.

9. Play the keyboard while singing into the microphone or playing audio with the audio device.

Adjust the A/D INPUT volume on the Control sliders.

Using the Vocoder

This instrument is equipped with a Vocoder. The Vocoder is an effect that processes the sound of the internal sound engine of this device using the characteristics of the voice input from the microphone. If you play the keyboard while speaking into the microphone, the sound of the instrument will change to sound like a robot voice.

This mechanism is based on the principle of how humans make sounds. The sound produced by the vocal cords resonates in the mouth and nose. The mouth and nose act like filters that enhance certain frequencies, creating formants (peaks at specific frequencies) in the sound.

The Vocoder effect applies this principle by extracting the filter characteristics of the voice input from the microphone and reproducing the formants with multiple bandpass filters. By passing the sound of musical instruments through it, a robot voice effect is created.

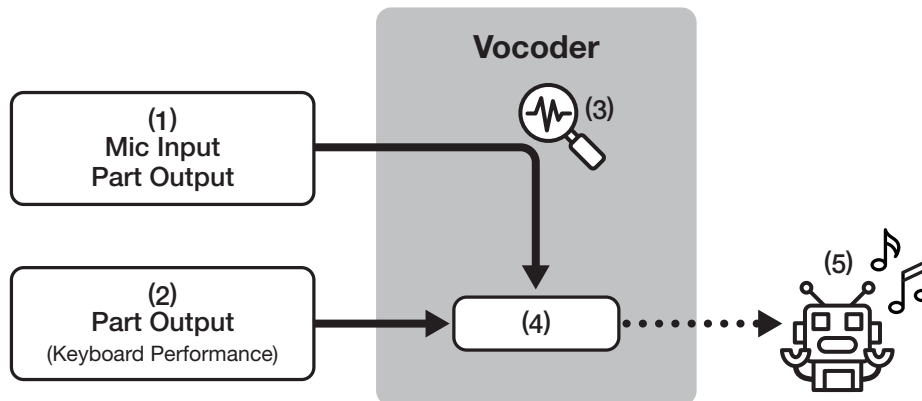

- (1) Mic Input or Part Output
- (2) Part Output (instrument output)
- (3) Extracting voice characteristics
- (4) Reproducing formants with filters
- (5) Robot-like voice

To use the Vocoder, connect the microphone, set the A/D Input settings in the Utility screen, and adjust the gain. Finally, select a Performance that uses the Vocoder effect, as shown below.

1. On the Performance screen, press the [CATEGORY] button.
2. Tap the button(s) on the screen to select the Pad/Choir category.

3. Tap the search box on the Category Search screen, and enter "Vocoder".

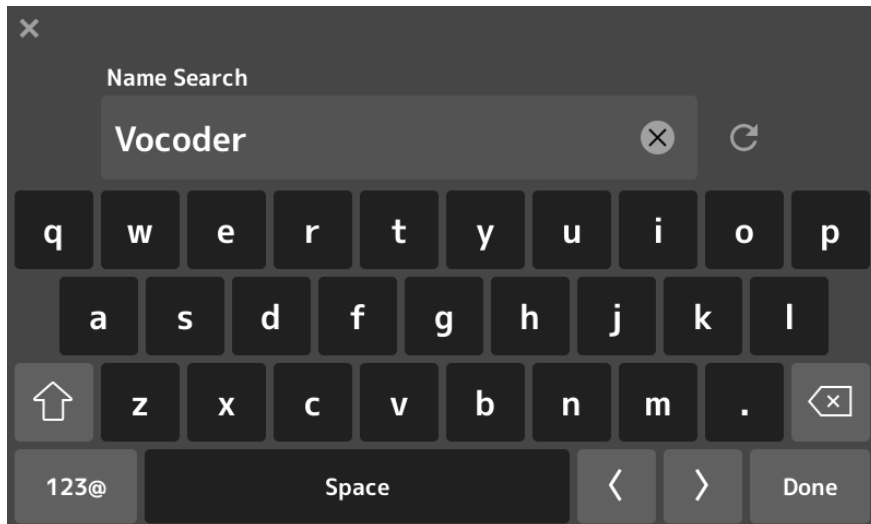

4. Set Filter to Attribute and select Single.

A list of Performances for Vocoder effects will be shown.

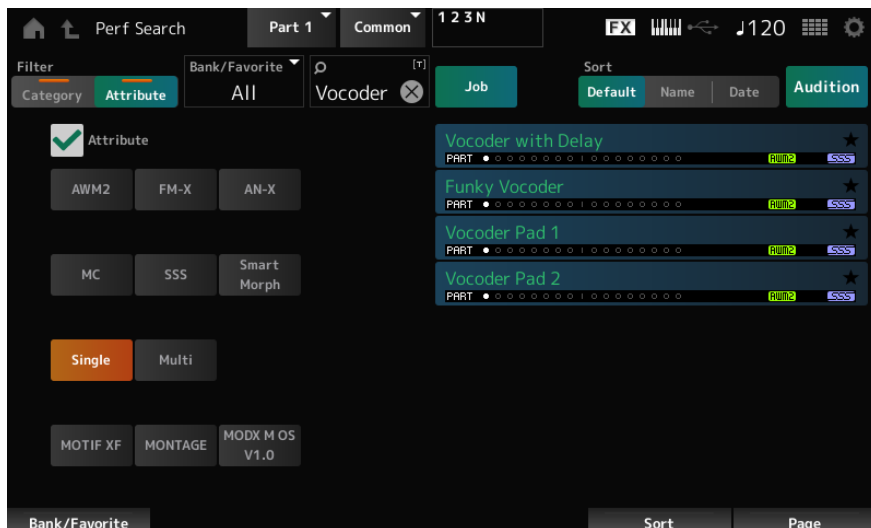

5. Select the desired Performance and press the [ENTER] button to confirm.

Connecting to a Computer or External MIDI Device

The USB and MIDI terminals on the rear panel are used for connecting to a computer and external MIDI devices. You can use these terminals to send Program Change messages to external MIDI devices when you change the Performance.

The Zone function is useful for setting up external MIDI devices.

Setting up the Zone function

The Zone function enables control of multiple external devices from the keyboard on this instrument.

You can set up to eight zones for each performance.

For example, you can use this function to switch between the internal sound engine and connected external sound engines by velocity or note range.

1. Press the [PERFORMANCE (HOME)] button to open the Performance screen.
2. Select a part, then open the screen by selecting [EDIT/COPY] → General/Pitch → Zone Settings.

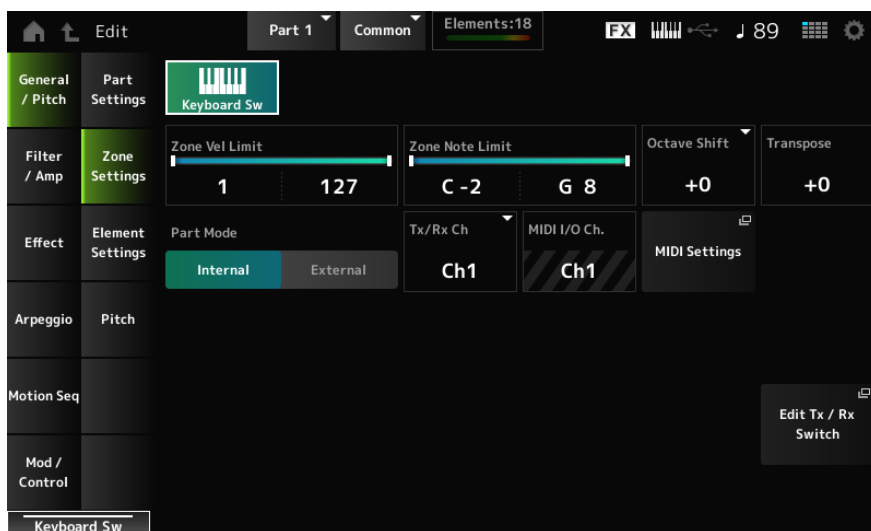

3. Check the Part Mode settings.

Select Internal to play the sound from the sound engine, and External to play the sound from the external sound engine.

NOTE

You can toggle between Part Mode Internal and External by quickly pressing the PART button twice when the [PART SELECT] button is on.

4. If necessary, set the parameters for Tx/Rx Ch (Transmit-Receive Channel) and Note Limit.
5. Press the [STORE] button to save the Performance.

Connecting and setting up a computer

By connecting your computer to this instrument, you can use a DAW or sequencer software on the computer to create your own music.

The acronym DAW (digital audio workstation) refers to music software for recording, editing, and mixing audio and MIDI. Typical DAW software includes Cubase, Logic, Pro Tools, and Live.

Connecting a computer and setting up

By connecting a computer to the USB [TO HOST] terminal, you can send and receive audio signals and MIDI messages. An AB-type USB cable and the driver for sending and receiving audio and MIDI are required for the connection.

In Windows you must install the Yamaha Steinberg USB Driver. On a Mac, it works with only the generic driver included in the OS, so no driver installation is required.

How to Install the Yamaha Steinberg USB Driver

1. Download the latest driver from the URL shown below.

<https://download.yamaha.com/>

NOTE

- Information on the system requirements is also available at the above URL.
- The Yamaha Steinberg USB Driver may be updated without prior notice for improvement purposes. For more details and the latest information, please check the URL above.

2. Unzip the downloaded file and install the Yamaha Steinberg USB Driver on your computer.

For instructions on how to install the driver, refer to the Installation Guide included in the downloaded file.

When connecting this instrument to a computer, use a USB cable to connect the USB [TO HOST] terminal to the computer's USB terminal as shown in the diagram below.

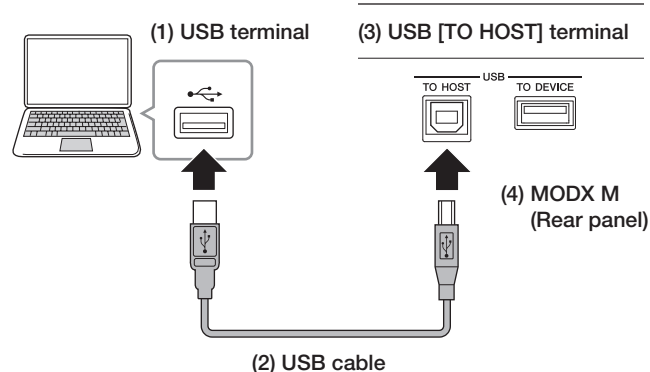

- (1) USB terminal
- (2) USB cable
- (3) USB [TO HOST] terminal
- (4) Rear panel of this instrument

Setting up for sending and receiving audio and MIDI

Connect the computer with a USB cable, and then set the parameters for handling audio and MIDI through the USB connection.

- **Audio**

Can be used by simply connecting the USB cable. And, if necessary, change settings such as sampling frequency and gain.

- **MIDI**

Connect the cable and then set the parameters for transmitting and receiving. Please follow the steps below to set it up. Open the screen from the [UTILITY] → Settings → MIDI I/O → MIDI IN/OUT and select USB. Set this instrument to enable the transmission and reception of MIDI through the USB [TO HOST] terminal.

About audio channels

For the output of audio signals, you can use the USB [TO HOST] terminal and the OUTPUT jacks. The audio signal output to the USB [TO HOST] terminal is up to 10 channels (5 stereo channels) at a sampling frequency of 44.1 kHz.

To select which signal to output to a specific channel, open the screen from the [PERFORMANCE (HOME)] → Part selection → [EDIT/⟳] → General/Pitch → Part Settings, and select the appropriate Part Output.

For the input of audio signals, you can use the USB [TO HOST] terminal and A/D INPUT jacks.

Audio signals coming in through the USB [TO HOST] terminal can contain up to 4 channels (or 2 stereo channels), and the output levels for Digital In L/R and Main L/R are set on the Mixing screen or Performance Edit screen, and are output to the OUTPUT terminals.

In addition, the audio signal from the A/D INPUT terminal is sent to the A/D input section of this instrument on up to two channels (one stereo channel).

MIDI channels and MIDI ports

MIDI has 16 channels, but for large song data, 16 channels may be insufficient.

Therefore, the concept of MIDI ports exists to handle data with more than 16 channels. Each MIDI port can handle 16 channels.

- One MIDI cable can transmit data for one port (16 channels) at a time.
- However, a single USB cable is capable of handling MIDI data for up to 8 ports (or $16 \times 8 = 128$ channels) simultaneously.

On this instrument, the determined ports are provided for the USB terminals, as shown below.

Port 1: Port for handling the sound engine section of this instrument

Make sure to set to Port 1 on the external MIDI device or the computer, if you wish the sound engine to be played on the external MIDI device or the computer.

Port 2: Dedicated for using the DAW remote control.

Port 3: Dedicated for receiving MIDI messages from a MIDI device and sending them to another MIDI device for MIDI Thru.

- MIDI port 3 data received by the USB [TO HOST] terminal is passed through the MIDI [OUT] terminal.
- MIDI data received by the MIDI [IN] terminal is passed through the USB [TO HOST] terminal as MIDI port 3 data.

For sending MIDI messages between the instrument and the computer through the USB cable, you need to select the appropriate MIDI Port as well as the MIDI channel. Set the Port settings on the external device suitable for the situation.

Using the MIDI 2.0 functions

This instrument supports MIDI 2.0 functionality. By connecting this instrument to a computer that meets the MIDI 2.0 operational requirements, you can use data of higher resolution than that of any MIDI 1.0 instrument. For more information about MIDI 2.0, see the MIDI 2.0 site (<https://www.yamaha.com/2/midi-2-0/>).

For details on the supported MIDI 2.0 messages, refer to the Data List.

<https://download.yamaha.com/>

To use the MIDI 2.0 functionality, first access the setting from [UTILITY] → Settings → Advance → USB Driver Mode and set Legacy Mode to Off, then connect a computer that meets the MIDI 2.0 operating requirements.

About music production using the computer

By connecting this instrument and the computer, you can use the DAW software as in the examples shown below.

- Using the DAW software on the computer to record your keyboard performance in MIDI or audio
- Using the tone generator block to play back the Song recorded on the DAW software

These instructions assume that the instrument and the computer are already connected. Shown below are some examples of using the DAW software and this instrument.

MIDI recording of your keyboard performance on the DAW

This shows how to record your keyboard performance on the DAW as MIDI data.

Settings on this instrument

1. Open the screen by going to [UTILITY] → Settings → Quick Setup.
2. Select MIDI Rec on DAW.

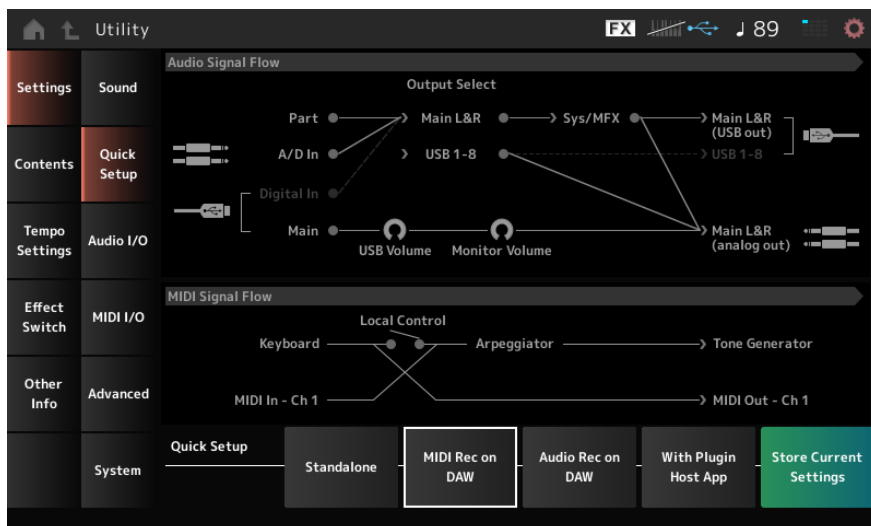

3. Press the [EXIT] button to close the Quick Setup screen, or press the [PERFORMANCE (HOME)] button to open the Performance screen and select the Performance you want to record.

The setting on the DAW software

1. Enable MIDI Thru.

MIDI Thru is a setting used for sending MIDI messages from the built-in keyboard to the computer and back to the Tone generator block of the instrument according to the settings on the recording tracks.

As shown below, for example, the MIDI data entered from this instrument is sent to Channel 1. If MIDI Thru is set to ON on the computer, then the MIDI data is sent to Channel 3 from the computer to play the sound engine at Channel 3. By using this setup, you can record the keyboard performance while listening to the same sound as the final output.

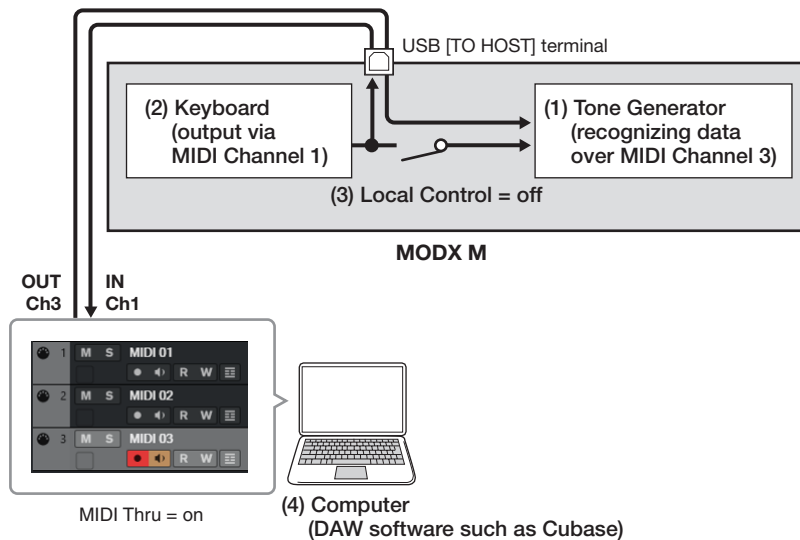

- (1) Tone generator block (recognizing data over MIDI Channel 3)
- (2) Keyboard (Ch1)
- (3) Local Control = OFF
- (4) Computer (DAW software such as Cubase)

2. Record the instrument performance on the DAW.

Using the sound engine to play back Songs on the DAW

This shows how to use the DAW software as a Multi-timbral sound generator.

It allows you to use the high-quality MIDI sound generator without placing too much load on your computer's CPU.

Settings on this instrument

1. Select a Performance.

After selecting a Performance, you may find it helpful to use the Mixing screen from: the [PERFORMANCE (HOME)] → Mixing to mix Part 1 to 16.

From the [UTILITY] → Effect Switch screen, set Kbd Ctrl Lock to ON to set the Tx/Rx Ch. of each Part to enable the reception of messages.

The setting on the DAW software

1. With the tracks you wish to use for playing the sound engine, set the MIDI output to Port 1 on this instrument.

2. Enter the MIDI data for each track.

The sound engine corresponding to each track's MIDI channel is set on the Mixing screen of this instrument.

Using Expanded Softsynth Plugin for MONTAGE M/MODX M

Expanded Softsynth Plugin for MONTAGE M/MODX M is a software synthesizer with the same sound engine system as the hardware MONTAGE M and MODX M.

Since this software works in sync with the hardware MONTAGE M or MODX M, the same sounds can be seamlessly integrated into your music production (where software is most convenient for a DAW), and into your live performance (where the actual instrument is used onstage). This lets you use either version of the MONTAGE M or MODX M, depending on your personal preferences and specific application.

For more information on the installation and activation of the ESP, access the MODX M Welcome page from the Expanded Softsynth Plugin for MONTAGE M/MODX M Download Information leaflet included with the instrument.

ESP Manual can be downloaded from the website below.

<https://download.yamaha.com/>

Using the DAW Remote function

The DAW Remote function allows you to control the DAW software from the controllers on the top panel of this instrument. This function can only be used when the instrument is connected to a computer with a USB cable. It cannot be used when connected with a MIDI cable.

Settings on this instrument

1. Use an AB-type USB cable to connect a computer to the USB [TO HOST] terminal of the instrument.
2. Select the DAW software from: [DAW REMOTE] → Settings → DAW.

The setting on the DAW software

This section explains how to set up the DAW software.

Depending on the version of your DAW software, the setup procedure may be different or the setup itself may not be possible. For details, please refer to the relevant owner's manual for the DAW software you are using.

NOTE

Once the connection between the computer and this instrument is lost, the DAW software may not recognize this instrument even after reconnection. If this happens, restart the DAW after the reconnection.

• Cubase

1. Device/Studio → Device Settings.../Studio Setup... to open the dialog box.
2. Select MIDI → MIDI Port settings, and uncheck All MIDI Input for Port 2 of MODX M-2 or MODX M.
3. Press the [-] button on the upper left corner of the dialog, and then select Mackie Control from the list.
4. Select Remote Devices → Mackie Control.
5. Set the MIDI Input and MIDI Output to MODX M-2 or MODX M Port2.
6. (Optional) Assign desired functions to F1–F8 of User Commands.

• Logic Pro

1. Select Logic Pro X → Preferences → Advanced → and check Show [Advanced Tools].
2. Logic Pro X → Control Surfaces → Setup... to open the dialog box.
3. From New → Install..., select Mackie Designs from Mackie Control.
4. Set the Output Port and the Input Port of Mackie Control to MODX M Port2.
5. (Optional) From Logic Pro X → Control Surface → Controller Assignments... set the Zone to Control Surface: Mackie Control, then assign functions to Control F1–F8.

- **Pro Tools**

1. Setup → Peripherals... to open the dialog box.
2. Select the MIDI Controllers tab.
3. Set the Type to HUI and the Receive From and Send To to the predefined ones (Predefined) MODX M-2 or MODX M, Port2.

- **Live**

1. Live → Preferences... to open the dialog box.
2. Select the Link/MIDI tab.
3. Select MackieControl for the Control Surface.
4. Set the MIDI Input and MIDI Output to MODX M-2 or MODX M Port2.
5. (Optional) Assign desired functions to F1–F8 by setting the operation of MIDI Note F#2–C#3 in the MIDI Map Assign Mode.

Connecting a smart device

You connect a smart device such as a smartphone and a tablet to this instrument.

Smart device apps that are compatible with this instrument provide many more convenient and enjoyable ways to use this musical instrument.

For more information on the apps and supported devices, refer to the Yamaha website.

For details on how to connect, search for "Smart Device Connection Manual" on the Yamaha website.

To use audio communication with an iOS device, please prepare the following adapters according to the type of connector/terminal.

- Lightning Terminals: Lightning to USB 3 Camera Adapter
- USB Type-C port: USB-C Digital AV Multiport Adapter

When connecting a smart device, on the instrument go to [UTILITY] → Settings → USB Driver Mode and set it to Generic.

Connecting External MIDI Instruments

Using USB cables and standard MIDI cables (that are commercially available), you can connect an external MIDI instrument to this instrument.

You can play an external MIDI instrument from the built-in keyboard, or play the tone generator block from an external MIDI keyboard or sequencer.

NOTE

You can use either the USB [TO DEVICE] terminal or the MIDI terminal to connect the external MIDI device.

Connecting an external MIDI device to MIDI terminals

When using MIDI terminals, connect an external MIDI device with MIDI cables, and then select MIDI from [UTILITY] → Settings → MIDI I/O.

Controlling an external MIDI sound engine with this instrument

You can play sounds from an external MIDI sound engine using the keyboard on this instrument or by song playback. To play the sounds from the internal sound engine and external MIDI sound engine separately, use the Zone function. Make sure to match the MIDI Transmit Channel of the external MIDI device with the MIDI Receive Channel of the instrument.

Setting the MIDI receive channel for this instrument

The MIDI output channel on this instrument should be set to a different value, depending on whether there are any Parts with Part Mode set to External.

- **If Part Mode does not have any External Parts**

Parts with Common or Keyboard Control Switch set to ON: MIDI I/O Ch.

Parts with Keyboard Control Switch set to OFF: Tx/Rx Ch.

- **If Part Mode does have External Parts**

Parts with Common or Keyboard Control Switch set to ON: Tx Ch. for which the Part Mode is set to External and Keyboard Control Switch is set to ON

Parts with Keyboard Control Switch set to OFF: Part Mode is set to External and other Part's Tx Ch.

*Any Parts with Part Mode set to Internal will not transmit MIDI messages.

Setting the receive channel for an external MIDI sound engine

Please refer to the instruction manual for the external MIDI sound engine.

When you wish to play the sound only from the external sound engine, lower the volume on this instrument, or set Local Control to OFF from [UTILITY] → Settings → MIDI I/O.

Playing the sounds of this instrument with an external MIDI keyboard

You can use the keys on an external MIDI keyboard to play this instrument's Performances and change Performances. Make sure to match the MIDI Transmit Channel of the external MIDI device with the MIDI Receive Channel of the MODX M.

Setting the MIDI receive channel for this instrument

Parts with Keyboard Control Switch set to ON: MIDI I/O Ch.

Parts with Keyboard Control Switch set to OFF: Tx/Rx Ch.

* If the Part Mode is set to External, the Part will not receive MIDI messages from the external device.

Setting the transmit channel for an external MIDI keyboard

Please refer to the Owner's Manual for your external MIDI keyboard.

Connecting a USB MIDI keyboard to the USB [TO DEVICE] terminal

By connecting a USB MIDI keyboard to the USB [TO DEVICE] terminal, you can use the connected keyboard just like the built-in keyboard, depending on the functions of the connected USB MIDI keyboard.

NOTICE

- The rating of the USB [TO DEVICE] terminal is a maximum of 5 V/500 mA. Do not connect USB devices having a rating above this, since this can cause damage to the instrument itself.
- Use an AB-type USB cable of less than 3 meters.

Compatible MIDI devices

- USB class-compliant MIDI devices
USB MIDI keyboard, etc.
- Yamaha MIDI devices that have been tested for compatibility
CP88, CP73, MODX, MODX+, MONTAGE, MOTIF XF, MOXF, MX, reface, YC, MONTAGE M, SEQTRAK

Special notes concerning MIDI communication

MIDI communication with a device connected via the USB [TO DEVICE] terminal follows special rules for allowing the device to behave like a built-in keyboard.

- MIDI communication is one-way only (sent from the external MIDI device and received by this instrument).
- All MIDI data is received regardless of the MIDI IN/OUT and MIDI I/O Ch. settings.
- For Parts with Keyboard Control Switch set to ON, data received on all corresponding channels is shared.
(For example, when Keyboard Control Switch for Parts 1 to 3 is set to ON, data received from any of channels 1 to 3 will be delivered to all Parts 1 to 3.)
- Each Part with Keyboard Control Switch set to OFF receives the data of only the corresponding channel for the Part.

6. Screens and parameters

Navigation bar

This chapter explains the Navigation bar, which is always displayed on the screen.



(1) HOME icon

This has the same function as the [PERFORMANCE (HOME)] button on the top panel. Tap to display the Performance screen (HOME).

(2) EXIT icon

This has the same function as the [EXIT] button on the top panel. Tap to return to the screen one level higher.

(3) INFORMATION area

This area displays information such as the currently selected screen name, part, element, operator, oscillator, and drum key.

Tap ▼ to switch parts, elements, operators, oscillators, and drum keys.

• Normal Part

When a Normal Part is selected, the status of the elements, operators and oscillators is displayed on the right side of this area.

When muted, an M icon appears below the number.

	<p>Element (AWM2) When an element is sounding, the ● below the number lights up to ○. When dividing elements according to velocity, you can check which element is being played.</p>
	<p>The total number of set elements The indicator shows the volume of the element being played</p>
	<p>Operator (FM-X)</p>
	<p>Oscillator (AN-X)</p>

• Drum Part

When a Drum Part is selected, the status of the drum key is displayed on the right side of this area.

	<p>The total number of set drum keys The indicator shows the volume of the drum part being played</p>
--	---

(4) VIEW icon



This function allows you to select the view on the Performance screen. Tap to display the view list on the Performance screen.

(5) EFFECT icon

Tap to display the Effect Switch screen. When the Insertion Effect, System Effect, or Master Effect is turned Off, the indicator turns off.

(6) QUICK SETUP icon

Tap to display the MIDI I/O screen.

	Displays on or off for Local Control On when the icon is on, Off when it is off.
	Displayed when MIDI IN/OUT is set to MIDI
	Displayed when MIDI IN/OUT is set to USB

(7) TEMPO SETTINGS icon

Displays the tempo of the currently selected Performance. Tap to display the Tempo Settings screen.

(8) LIVE SET icon

Tap to display the Live Set screen.

The currently selected slot is displayed in blue.

(9) UTILITY icon

Tap to display the most recently opened Utility screen.

Performance Screens

The Performance screen lets you select a Performance for playing on the keyboard or modify the Performance settings to customize the Performance.

HOME

Operation

Press the [PERFORMANCE (HOME)] button

Tap the HOME icon (🏠)

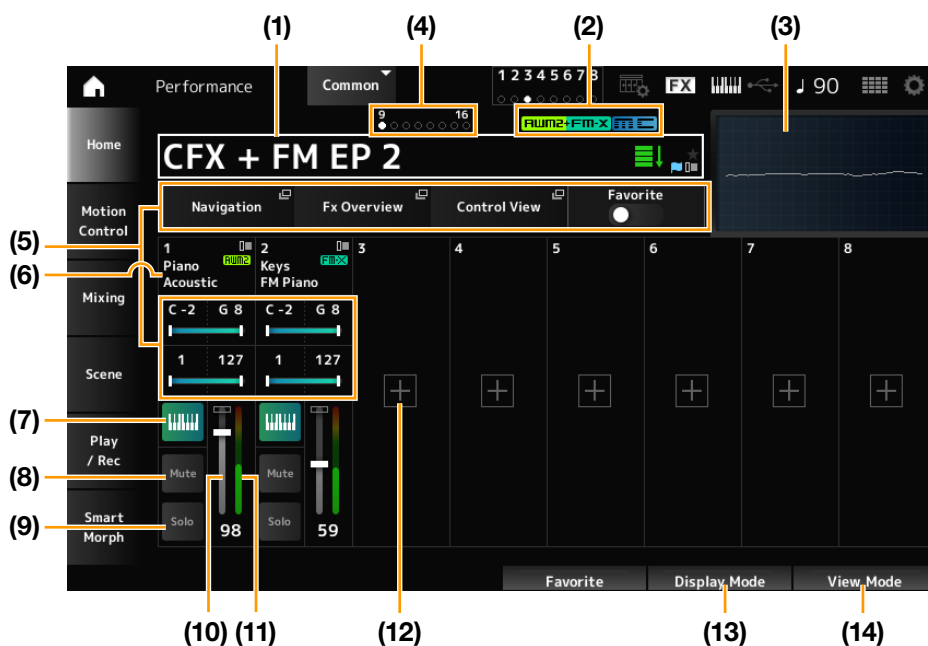

(1) Performance Name

Shows the name of the selected Performance. Tap to display the context menu for Category Search, Edit, Recall, etc.

You can switch Performances using the Data dial, the [INC/YES] button, and the [DEC/NO] button. There are two ways to switch.

- **Default** (📄) Switches in the order of the Performance list on the Performance Category Search screen.
- **Live Set** (🎹) Switches in the order of the Live Set slots.

You can set the switching method from [UTILITY] → Settings → System → Perf Inc/Dec.

You can check the status of the Performance with the flags.

- **Favorite Flag** (★) A ★ will be shown when you turn on the Favorite switch. It will also be displayed on the Performance Category Search screen.
- **Edit Flag** (🔵) The blue flag will be shown when you change a parameter in the Performance. The Edit flag will be turned off when you save the settings with the [STORE] button.

(2) Performance Flag

The Performance flags are displayed.

Attribute	Description
AWM2	A Performance consisting only of AWM2 sound engine parts
FM-X (1 color)	A Performance consisting only of FM-X sound engine parts
FM-X (2 colors)	Performances using an FM-X Part containing the Smart Morph information
AN-X (1 color)	Performances using the AN-X sound engine
AN-X (2 colors)	A Performance using an AN-X Part containing the Smart Morph information
MC	Performances featuring Motion Control
SSS	A Performance that supports Seamless Sound Switching

* Performances that combine multiple sound engine types are indicated with the “+” sign.

(3) Oscilloscope

The Main L&R output is displayed as a waveform.

(4) Part Indicator

When the cursor is on either Performance Name or Parts 1 to 8, the status for Parts 9 to 16 will be shown.

When the cursor is on Parts 9 to 16, the status for Parts 1 to 8 will be shown.

Nothing will be shown when Parts 9 to 16 are not used.

(5) View area for various parameters

Different parameters will be shown in this view area depending on the Display Mode.

(6) Part Name

Part Type and Category, or Part Name will be shown.

Tap to display the context menu for Category Search, Edit, Copy, and Property.

When a Part other than Part 1 is selected and the sound is already set for that Part, the context menu for Category Search, Edit, Copy, and Delete is displayed.

(7) Keyboard Control Switch

You can set which Parts will play simultaneously by turning each Part's Keyboard Control Switch on or off.

If the Part is set to Common or the Keyboard Control Switch for the Part is set to On, you can simultaneously play Parts having the Keyboard Control Switch set to On.

If the Keyboard Control Switch for the Part is set to Off, when you play the keyboard with that Part selected, those sounds will be played.

Settings: Off, On

(8) Part Mute

Switches Part Mute on or off.

Settings: Off, On

(9) Part Solo

Switches Part Solo on or off.

Settings: Off, On

(10) Part Volume

Sets the volume of the Part.

Settings: 0–127

(11) Part Level Meter

Shows the audio output level for the Part.

(12) [+] (Add)

Tap to display the Part Category Search screen or Performance Merge screen, which allows you to add a Part.

(13) Changing the Display Mode

(14) Changing the View Mode

Changing the Display Mode

When you change the Display Mode, different parameters will be shown in the view area of the Home screen. You can select a different Display Mode by moving the corresponding display knob.

■ Range



Navigation

The Navigation screen will open.

Fx Overview

The FX Overview screen will open.

Control View

The Control View screen will open.

Favorite

Turns the Favorite switch on or off.

Settings: Off, On

Note Limit

Sets the note range (the lowest and the highest notes) for the Part.

When the first note specified is higher than the second (for example, C5 to C4), the notes in the ranges C-2 to C4 and C5 to G8 will be played.

Settings: C-2-G8

Velocity Limit

Sets the velocity range for the Part.

Settings: 1-127

■ FX/Pan



Var Return

Sets the output level (Return Level) of the signals processed by the Variation Effect.

Settings: 0–127

Rev Return

Sets the output level (Return Level) of the signals processed by the Reverb Effect.

Settings: 0–127

Pan

Adjusts the Pan position (stereo position) of the currently selected Performance.

Settings: L63–C (center)–R63

Volume

Adjusts the volume of the currently selected Performance.

Settings: 0–127

Var (Part Variation Send)

Sets the level of the signals sent to the Part Variation Effect.

Settings: 0–127

Rev (Part Reverb Send)

Sets the level of the signals sent to the Part Reverb Effect.

Settings: 0–127

Dry (Part Dry Level)

Sets the dry level (or the level of the signals not processed by the System Effect) of the Part.

Settings: 0–127

Pan (Part Pan)

Adjusts the Pan position (in the stereo field) for the Part.

Settings: L63–C (center)–R63

■ Arp/MS/Porta



Arp Select

Selects the Arpeggio.

Settings: 1–8

MS Select

Changes the Motion Sequence selection.

Settings: 1–8

Portamento Switch

Sets Portamento on or off for Parts having the Portamento Part Sw set to On.

This switch is linked to the [PORTAMENTO] button on the top panel.

Settings: Off, On

Portamento Time

Sets the time length (or speed) for the pitch transition of Portamento for the Part.

This is the offset value for the Part's Portamento Time (the value adjusted relative to the reference).

Settings: –64–+0–+63

Arp On/Off (Arpeggio Part Switch)

Sets the Arpeggio on or off for the Part.

When both Arpeggio and Arpeggio Hold are On, Arp Hold On will be displayed.

When the Arpeggio is set to On, you can switch Arp Hold On or Off by simultaneously holding down the [SHIFT] button and tapping the Arp On/Off button on the screen.

Settings: Off, On

MS On/Off (Motion Sequencer Part Switch)

Sets Motion Sequencer for the Part on or off.

Settings: Off, On

Prt On/Off (Portamento Part Switch)

Sets Portamento for the Part on or off.

Settings: Off, On

Time (Portamento Part Time)

Sets the time length of the pitch transition for the Portamento of the Part.

Settings: 0–127

■ Mode/Transpose



MIDI I/O Ch.

Sets the MIDI channel for input and output of the Common and the Part with the Keyboard Control Switch to be set to On.
Settings: Ch1–Ch16

Octave Shift (Keyboard Octave Shift)

Shifts the pitch of the keys in octaves.
It is linked to the OCTAVE buttons on the top panel.
Settings: –3–+0–+3

Transpose (Keyboard Transpose)

Shifts the pitch of the keys in semitones.
Settings: –11semi to +0semi to +11semi

NOTE

If the pitch exceeds the range (C-2 to G8) that the sound source section of the unit can play, a note one octave higher (or lower) will be output.

Int/Ext (Part Mode)

Set whether to use the built-in sound source of the instrument (Int) or an external sound source (Ext).
Settings: Int, Ext

Ch (Tx/Rx Ch)

Sets the channel for transmitting and receiving MIDI messages for the Zone when Part Mode is set to Internal and the Keyboard Control Switch is set to Off.
Settings: Ch1–Ch16, Off

Ch (Transmit Ch)

Sets the channel for transmitting and receiving MIDI messages for the Zone when Part Mode is set to External.
Settings: Ch1–Ch16

Oct (Zone Octave)

Shifts the pitch of the zone in octaves.
Settings: –3–+0 (standard)–+3

Trans (Zone Transpose)

Shifts the pitch of the zone in semitones.
Settings: –11–+0 (standard)–+11

■ Filter



Cutoff (Cutoff Frequency)

Changes the sound by setting the cutoff frequency of the filter.

When the Low Pass Filter is selected, larger values here result in a brighter sound, and smaller values result in a darker sound.

This is specified as an offset value to the filter cutoff frequency for the Part.

Settings: -64+0+63

Resonance

Adds special characteristics to the sound by adjusting the signal level near the cutoff frequency.

This is specified as an offset value to the filter resonance for the Part.

Settings: -64+0+63

FEG Depth

Sets the depth range for the cutoff frequency change controlled by the FEG.

This is specified as an offset value to the Part's FEG Depth.

Settings: -64+0+63

Cut (Part Cutoff Frequency)

Changes the sound by setting the cutoff frequency of the Part's filter.

When the Low Pass Filter is selected, larger values here result in a brighter sound, and smaller values result in a darker sound.

This is specified as an offset value to the filter cutoff frequency set on the Filter Type screen.

Settings: -64+0+63

Res (Part Resonance)

Adds special characteristics to the sound by adjusting the signal level near the Part's cutoff frequency.

This is specified as an offset value to the filter resonance set on the Filter Type screen.

Settings: -64+0+63

FEG (Part FEG Depth)

Adjusts the range of the cutoff frequency change controlled by the FEG setting in the Filter Type screen.

When it is set to 0, the settings in the Filter Type screen will be used as is.

Settings: -64+0+63

Changing the View Mode

You can access more detailed information from the Home screen by using View Mode.

You can select a different View Mode by moving the corresponding display knob.

When the cursor is on the Performance Name, pressing the [PERFORMANCE (HOME)] button also changes the view.

■ Part Info

• Element Sw/Level

Displayed when the currently selected Part is a Normal Part (AWM2).

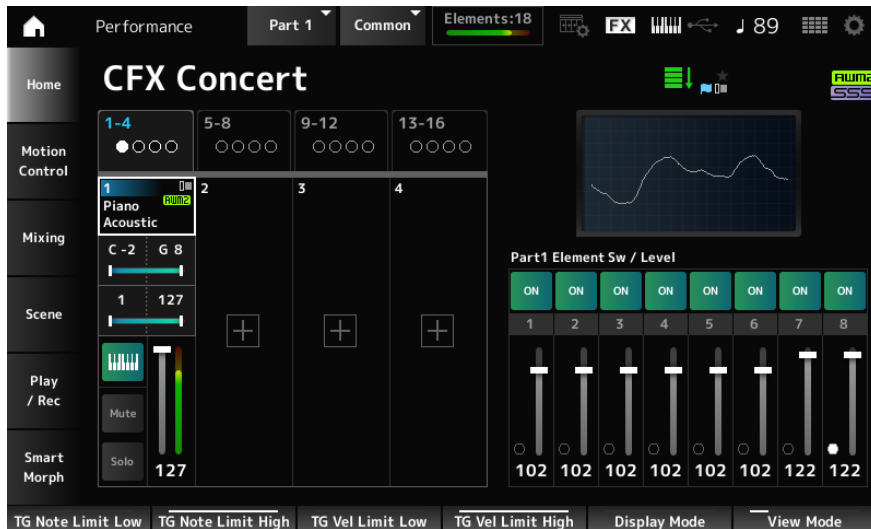

Element Sw (Element Switch)

Switches the Element On or Off.

Settings: Off, On

Element Level

Sets the output level for the Element.

Settings: 0–127

• Drum Key

Displayed when the currently selected Part is a Drum Part.



Drum Key Level

Sets the output level for the Drum Key.

Settings: 0–127

- **Algorithm**

Displayed when the currently selected Part is a Normal Part (FM-X).

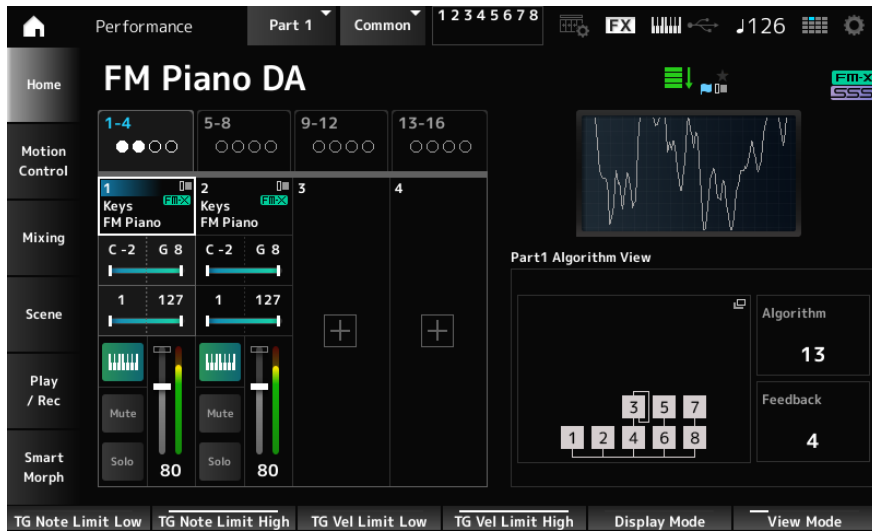

Algorithm (Algorithm Number)

Changes the Algorithm.

Tapping the Algorithm image calls up the Algorithm Search screen.

Settings: Refer to the Data List

Feedback (Feedback Level)

Set the degree (level) of feedback (modulating the modulator itself using the output waveform of the carrier modulated by the modulator).

Settings: 0–7

- **Virtual Analog**

Displayed when the currently selected Part is a Normal Part (AN-X).

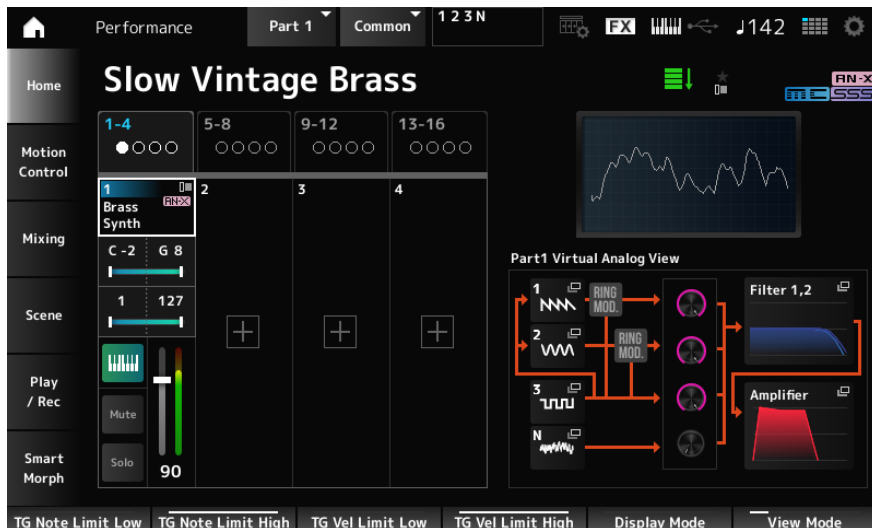

1–3 (Oscillator 1–3)

Opens the OSC/Tune screen for Part Edit (AN-X).

N (Noise)

Opens the Noise screen for Part Edit (AN-X).

Oscillator Level

Sets the output level for the Oscillator.

Settings: 0–511

Noise Level

Sets the noise level.

Settings: 0–511

Filter 1, 2

Opens the Filter Type screen for Part Edit (AN-X).

Amplifier

Opens the Amp EG screen for Part Edit (AN-X).

■ Smart Morph

The Smart Morph map is displayed.

However, the map will not be shown when there is no Smart Morph information.

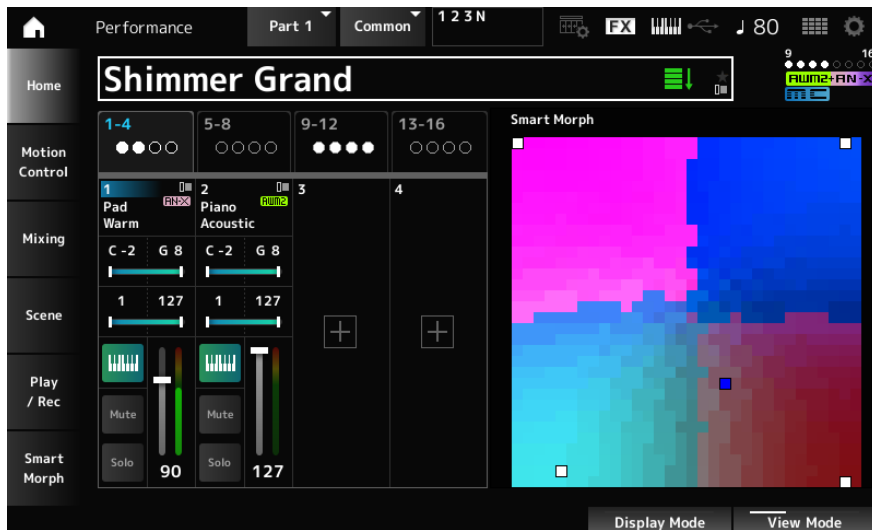

■ Motion Seq

Shows the lane set in the View Lane of the currently selected Part.

However, it will not be displayed if the set lane is Off.

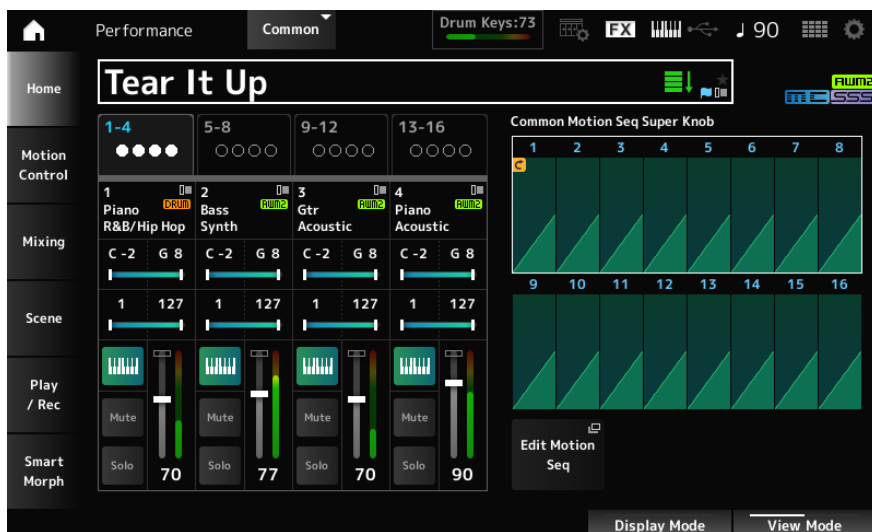

■ Velocity - Note

The Velocity - Note view is displayed.

This is convenient for setting velocity splits when using multiple Parts.

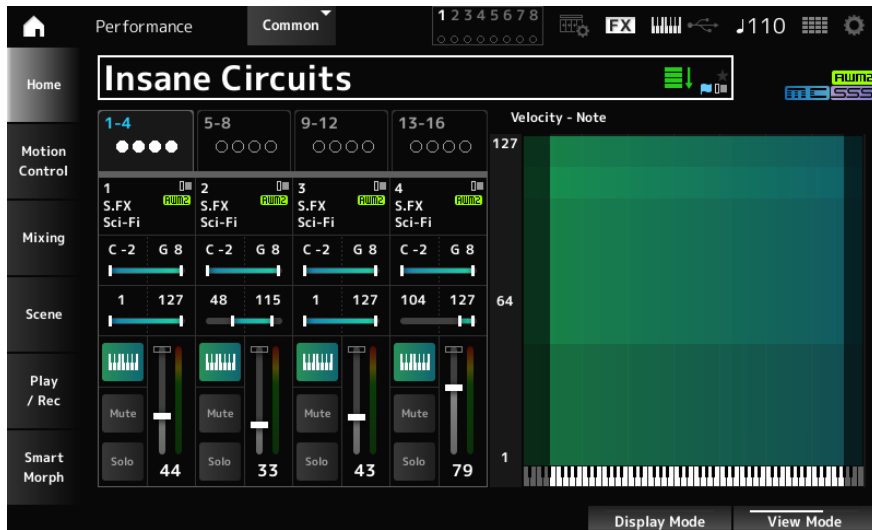

■ Part - Note

The Part - Note view is displayed.

Shown when the View Mode is set to Part Info and the selected Part is Common.



■ Ribbon

Shown when the View Mode is Ribbon.

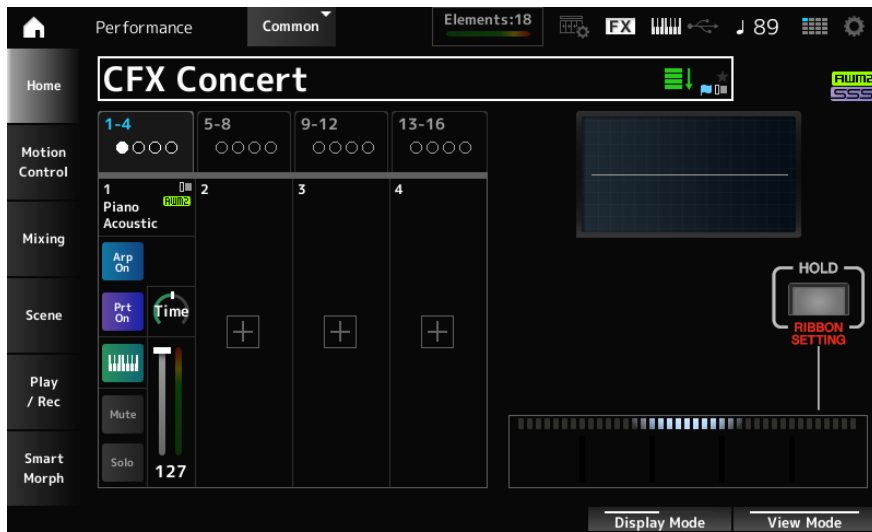

Motion Control

On the Motion Control screen, you can set the Motion Control settings applied to the entire Performance.

Super Knob

On the Super Knob screen, you can set the values for controlling the Super Knob.

You can set a link between the Super knob and each of the assignable knobs.

Operation

[PERFORMANCE (HOME)] → Motion Control → Super Knob

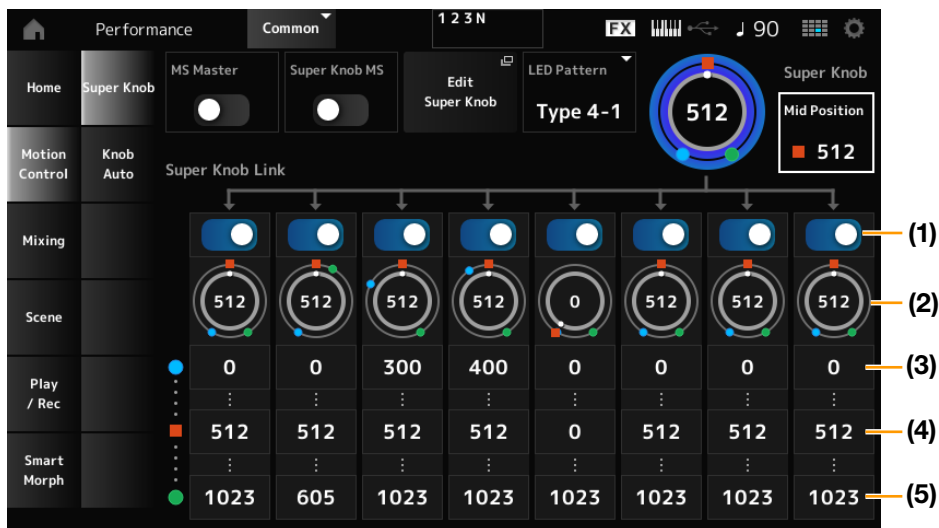

(1) Super Knob Link

(2) Assignable Knob 1–8 Value

(3) Assignable Knob 1–8 Value Left

(4) Assignable Knob 1–8 Value Mid

(5) Assignable Knob 1–8 Value Right

MS Master (Motion Sequencer Master Switch)

Sets the Motion Sequencer for the entire Performance on or off.

This switch is linked to the [MSEQ] buttons on the top panel.

Settings: Off, On

Super Knob MS (Super Knob Motion Sequencer Switch)

Sets the Motion Sequencer used for the Super Knob on or off.

Settings: Off, On

Edit Super Knob

The Common Edit Control Assign screen will open. You can set the parameters to be controlled by the Super Knob.

LED Pattern

Sets the lighting pattern of the Super knob.

Settings: Off, Type 1, Type 2-1, Type 2-2, Type 3-1, Type 3-2, Type 4-1, Type 4-2, Type 5-1, Type 5-2, Type 6, Type 7-1, Type 7-2, Type 8-1, Type 8-2, Type 9, Type 10, Type 11, Type 1B, Type 2-1B, Type 2-2B, Type 3-1B, Type 3-2B, Type 4-1B, Type 4-2B, Type 5-1B, Type 5-2B, Type 6B, Type 7-1B, Type 7-2B, Type 8-1B, Type 8-2B, Type 9B, Type 10B, Type 11B, Rotary 1, Rotary 2, Rotary 3, Rotary 4, Rotary 5, Rotary 6, Rotary 7, Rotary 8, Rotary 9, Rotary 10

Super Knob (Super Knob Value)

Sets the Super Knob value.

Settings: 0–1023

Mid Position (Super Knob Mid Position)

Set the Mid value for the Super Knob.

Settings: Off, 1–1022

Super Knob Link

Sets the corresponding knob to link to the Super Knob.

When these switches are set to Off, the operation of the Super Knob will not affect the parameter of the knob.

Settings: Off, On

Assignable Knob 1 – 8 Value

Shows the current values for the Assignable knobs (Knobs 1–8).

Settings: 0–1023

Assignable Knob 1 – 8 Value Left

Shows the value of the assignable knobs (Knobs 1–8) when the Super Knob Value is set to 0 (or the Super Knob is turned all the way to the left).

Settings: 0–1023

Assignable Knob 1 – 8 Value Mid

Shows the value of the assignable knobs (Knobs 1–8) when the Super Knob Value is set to Mid Position.

This parameter is not available when the Mid Position is Off.

Settings: 0–1023

Assignable Knob 1 – 8 Value Right

Shows the value of the assignable knobs (Knobs 1–8) when the Super Knob Value is set to 1023 (or the Super Knob is turned all the way to the right).

Settings: 0–1023

NOTE

- When you set Value Left to a smaller value and Value Right to a larger value, Knobs 1–8 will move in the same direction as the Super Knob.
- When you set Value Right to a smaller value and Value Left to a larger value, Knobs 1–8 will move in the opposite direction to the Super Knob.

Knob Auto

In the Knob Auto screen, you can set the Motion Sequencer for the Super Knob (Super Knob Motion Sequencer). You can set the Motion Sequencer to automatically control the Super Knob value.

Only one Lane can be used by the Super Knob.

NOTE

Up to eight Lanes can be used at the same time for the entire Performance. However, the Lane used for the Knob Auto screen is not included in the eight referred to here.

Operation

[PERFORMANCE (HOME)] → Motion Control → Knob Auto

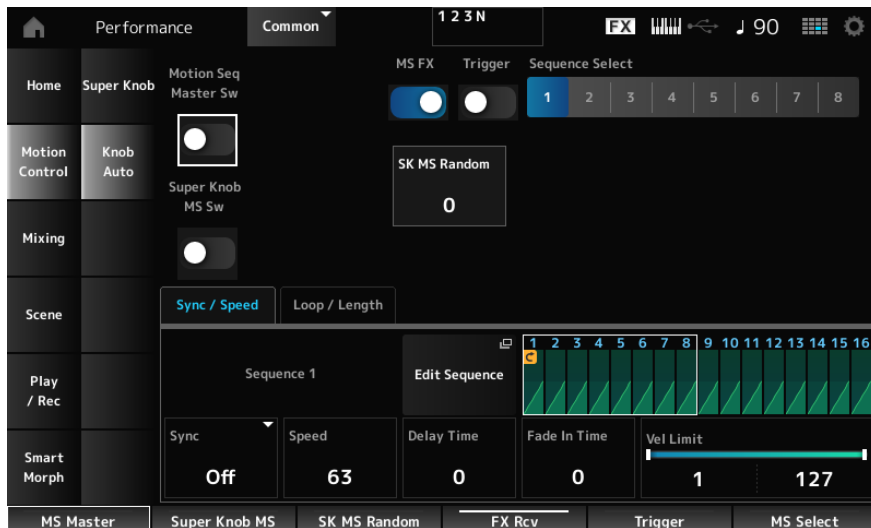

Motion Seq Master Sw (Motion Sequencer Master Switch)

Sets the Motion Sequencer for the entire Performance on or off.

This switch is linked to the [MSEQ] buttons on the top panel.

Settings: Off, On

Super Knob MS Sw (Super Knob Motion Sequencer Switch)

Sets the Super Knob Motion Sequencer on or off.

Settings: Off, On

MS FX (Super Knob Motion Sequencer FX Receive)

Sets Knobs to be affected by the operation of the Super Knob.

Settings: Off, On

Trigger (Super Knob Motion Sequencer Trigger Receive)

Sets to receive the signals from the [MSEQ TRIGGER] button.

When set to On, the Motion Sequence will not be played back unless you press the [MSEQ TRIGGER] button.

Settings: Off, On

Sequence Select (Motion Sequence Select)

Changes the Motion Sequence type selection.

Settings: 1–8

SK MS Random (Super Knob Motion Sequencer Randomness)

Sets randomness of the changes in the Step value of the sequence.

Settings: 0–127

Edit Sequence

The Super Knob Motion Sequence Edit screen will open.

■ Sync/Speed Tabs

Sync (Super Knob Motion Sequencer Sync)

Selects the speed and the timing for the playback of the Super Knob Motion Sequence.

Settings: Off, Tempo, Beat

Off: Plays back the Super Knob Motion Sequencer alone

Tempo: Plays back at the Performance tempo.

Beat: Plays back in sync with the beat.

• When Sync is set to Off

Speed (Super Knob Motion Sequencer Speed)

Sets the playback speed for the Motion Sequence.

Settings: 0–127

Delay Time (Super Knob Motion Sequencer Lane Key On Delay Time Length)

Sets the delay time for starting the playback of the Motion Sequence.

Settings: 0–127

Fade In Time (Super Knob Motion Sequencer Lane Fade In Time Length)

Sets the time for the Motion Sequence to reach maximum amplitude.

Settings: 0–127

• When Sync is set to something other than Off

Unit (Super Knob Motion Sequencer Unit Multiply)

Sets the percentage for stretching or compressing the Super Knob Motion Sequencer playback time.

Settings: 50%–6400%, Common

200%: The playback time is doubled, and the tempo is halved

100%: The playback time is kept unchanged

50%: The playback time is halved, and the tempo is doubled

Common: The value set in the Unit common to all Parts is applied

Delay Steps (Super Knob Motion Sequencer Lane Key On Delay Step Length)

Sets the delay time for starting the playback of the Motion Sequence.

Settings: 0–32

Fade In Steps (Super Knob Motion Sequencer Lane Fade In Step Length)

Sets the time to reach the maximum amplitude for the Motion Sequence.

Settings: 0–32

Vel Limit (Super Knob Motion Sequencer Velocity Limit)

Sets the velocity range (lowest and highest values) for playing back the Motion Sequence.

Settings: 1–127

■ Loop/Length Tabs

Key On Reset (Super Knob Motion Sequencer Key On Reset)

Resets the Motion Sequence playback when you press any key on the keyboard.

This parameter is not available when the Trigger is On.

Settings: Off, Each-On, 1st-On

Each-On: Each time you play any note, playback starts from the beginning

1st-On: Playback starts from the beginning at the first note you play. When the second note is played while the first note is held, playback will not be reset.

Loop (Super Knob Motion Sequencer Loop)

Sets the Motion Sequence to loop playback (in repeats) or one-shot playback.

Settings: Off, On

Loop Start (Super Knob Motion Sequencer Loop Start)

Specifies the starting point for the loop playback of the Motion Sequence.

Settings: 1–16 (should be below the Length setting)

Length (Super Knob Motion Sequence Length)

Sets the Motion Sequence length.

Settings: 1–16 (should be above the Loop Start setting)

MS Grid (Super Knob Motion Sequence Grid)

Sets the length of a step in the Motion Sequence.

Settings: 60, 80, 120, 160, 240, 320, 480

■ Super Knob Motion Sequence Edit

The setting screen for the Super Knob Motion Sequencer.

You can create a sequence of up to 16 steps.

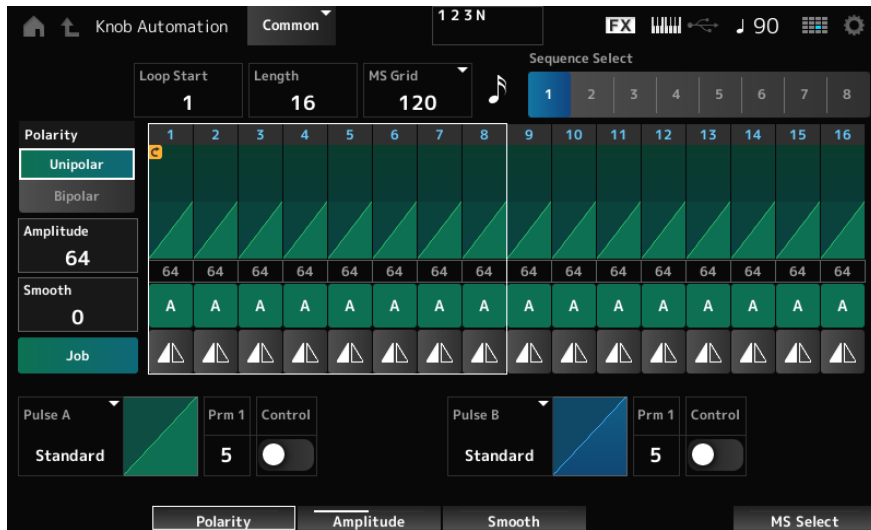

Loop Start (Super Knob Motion Sequencer Loop Start)

Specifies the starting point for the loop playback of the Motion Sequence.

Settings: 1–16 (should be below the Length setting)

Length (Super Knob Motion Sequence Length)

Sets the Motion Sequence length.

Settings: 1–16 (should be above the Loop Start setting)

MS Grid (Super Knob Motion Sequence Grid)

Sets the length of a step in the Motion Sequence.

Settings: 60, 80, 120, 160, 240, 320, 480

Sequence Select (Motion Sequence Select)

Changes the Motion Sequence type selection.

Settings: 1–8

Polarity (Super Knob Motion Sequence Polarity)

Sets the polarity of the Motion Sequence.

Settings: Unipolar, Bipolar

Unipolar: Only positive values are used for the parameter change

Bipolar: Both positive and negative values are used for the parameter change

Amplitude (Super Knob Motion Sequence Amplitude)

Sets the degree of changes in the Motion Sequence.

Settings: 0–127

Smooth (Super Knob Motion Sequence Smoothness)

Sets the smoothness of the changes in the Motion Sequence over time.

Settings: 0–127

Job

Calls up the Job menu.

- **Store Sequence**
Saves (stores) the edited Motion Sequence.
- **Load Sequence**
Loads the Motion Sequence.
- **Copy Sequence**
Copies the Motion Sequence.

Super Knob Motion Sequence Step Value

Sets the value for each step in the Motion Sequence.

You can use Control sliders 1 to 8 to change the values for Steps 1 to 8 and Steps 9 to 16, depending on the cursor position.

Settings: 0–127

Super Knob Motion Sequence Step Type

Sets the type and direction of each step in the Motion Sequence.

Settings: A, B, Reverse A, Reverse B

Pulse A (Super Knob Motion Sequence Step Curve Type A)

Pulse B (Super Knob Motion Sequence Step Curve Type B)

Selects a parameter change curve for Pulse A and Pulse B.

Use the Super Knob Motion Sequence Step Type to select which of the curve types to use for each step.

The vertical axis represents the time while the horizontal axis represents the step value.

Settings: (When a preset bank is selected) Standard, Sigmoid, Threshold, Bell, Dogleg, FM, AM, M, Discrete Saw, Smooth Saw, Triangle, Square, Trapezoid, Tilt Sine, Bounce, Resonance, Sequence, Hold, Harmonic, Steps

(When a user bank is selected) Init Curve 1–32

(When loading a Library file) Curve within Library 1–24

Edit User Curve

Displayed when Init Curve is selected for Pulse A and Pulse B.

The User Curve Edit screen will open.

Prm 1 (Super Knob Motion Sequence Step Curve Parameter 1)

Prm 2 (Super Knob Motion Sequence Step Curve Parameter 2)

Adjusts the shape of the step curve in the Motion Sequence. Also, the range for the parameter value differs depending on the Curve Type.

This setting is not available depending on the Curve Type.

Control (Super Knob Motion Sequence Step Curve Shape Control Switch)

Enables or disables the use of the knobs for controlling the step curve shape of the Motion Sequence.

Shown only when MS FX (Super Knob Motion Sequencer FX Receive) is set to On.

This setting is not available depending on the Curve Type.

Settings: Off, On

■ User Curve Edit

This is the setting screen for the User Curve.

You can create an 8-point Linear curve or an 8-step curve.

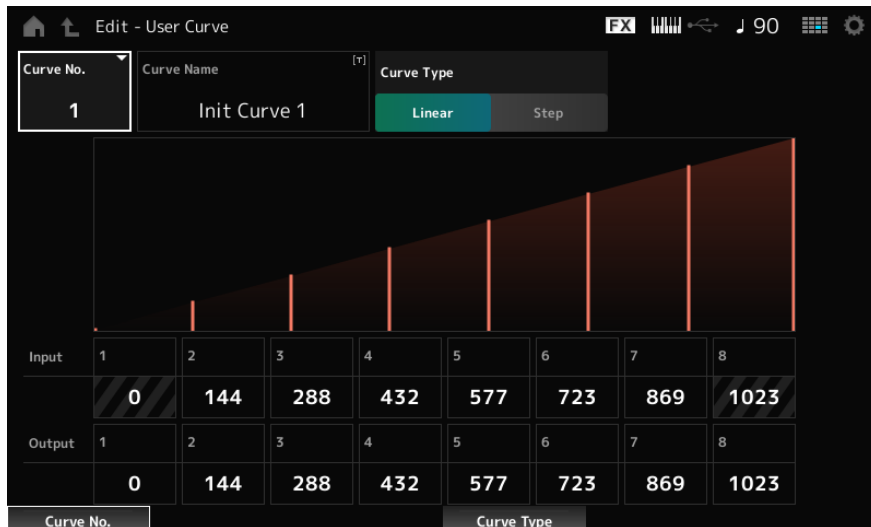

Curve No. (Curve Number)

Indicates the current curve number.

Settings: 1–32

Curve Name

You can save the curve you are editing under a new name. You can use up to 20 alphanumeric characters.

Curve Type

Sets the Curve type.

Settings: Linear, Step

Input

Sets the input level for the curve.

Input 1 is fixed to the value 0. Input 8 is fixed to the value of 1023 when the Curve Type is set to Linear.

Settings: 0–1023

Output

Sets the output level for the curve.

Settings: 0–1023

Mixing

On the Mixing screen, you can change the mix by adjusting the volume of each Part and make effect settings. The settings in the Mixing screen are saved (stored) in the Performance.

Operation

[PERFORMANCE (HOME)] → Mixing



Part 1–16 (Part 1–16 Switch)

Audio (Audio Switch)

Changes the view.

Settings: Part 1–16, Audio (Part 1–8, Audio Part, Master)

■ Part 1–16 view

Sets the mix for Parts 1 to 16.

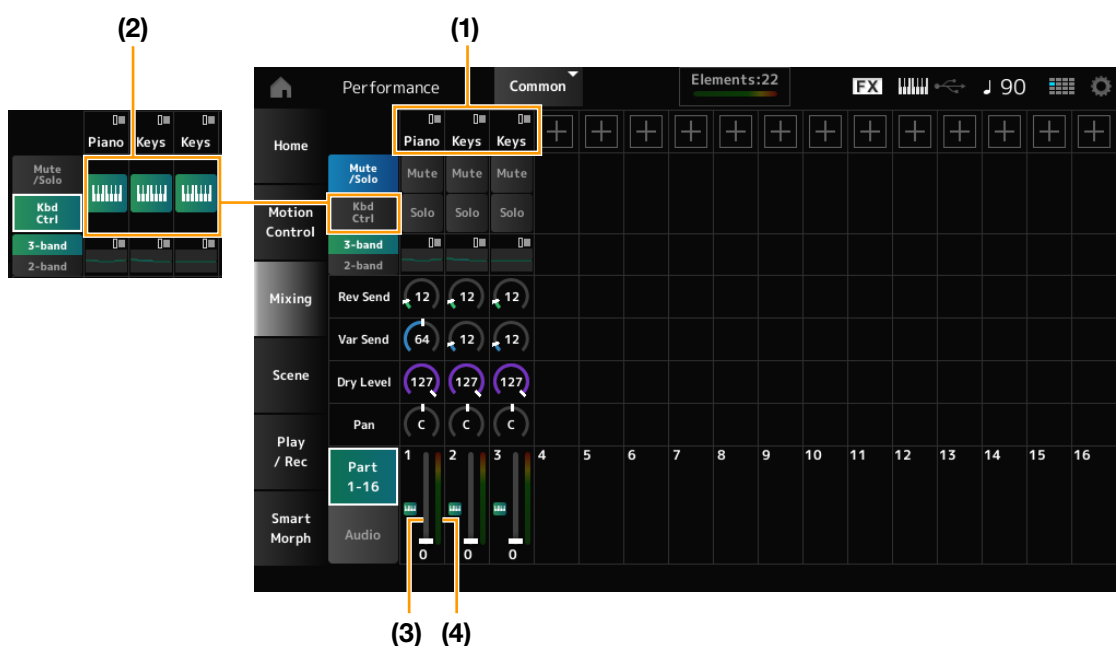

(1) Part Category

(2) Keyboard Control

(3) Volume

(4) Part Level Meter

Part Category

The Main category of the selected Part is shown.

Tap to display the context menu for Category Search, Edit, Property, etc.

When a Part other than Part 1 is selected and the sound is already set for that Part, the context menu for Category Search, Edit, Copy, and Delete is displayed. Tap [+] to add a Part.

Settings: Refer to the Data List

Mute/Solo Switch

Kbd Ctrl Switch

Switches between the Mute/Solo view and Keyboard Control view.

Mute (Part Mute)

Solo (Part Solo)

Switches Mute and Solo for the Part on or off.

Settings: Off, On

Keyboard Control

Switches Keyboard Control on or off.

For Parts 9 to 16, the buttons will not be shown since Keyboard Control cannot be set to On for those Parts.

Settings: Off, On

3-band (3-band EQ Switch)

2-band (2-band EQ Switch)

Switches between the 2-band EQ view and 3-band EQ view of Parts 1 to 16.

Settings: 3-band, 2-band

EQ (Equalizer)

Shows the EQ setting either in 3-band or 2-band views.

Tapping on the area calls up the context menu of Part EQ.

Rev Send (Reverb Send)

Sets the level of the signals sent from Parts 1 to 16 to the Reverb Effect.

Settings: 0–127

Var Send (Variation Send)

Sets the level of the signals sent from Parts 1 to 16 to the Variation Effect.

Settings: 0–127

Dry Level

Sets the dry level (or the level of the signals not processed by the System Effect) of Parts 1 to 16.

Settings: 0–127

Pan

Adjusts the Pan position (in the stereo field) for Parts 1 to 16.

Settings: L63–C (center)–R63

Volume

Sets the volume for Parts 1 to 16.

Settings: 0–127

Part Level Meter

Shows the level for Parts 1 to 16.

■ Audio view

Sets the mix for the Audio Part.

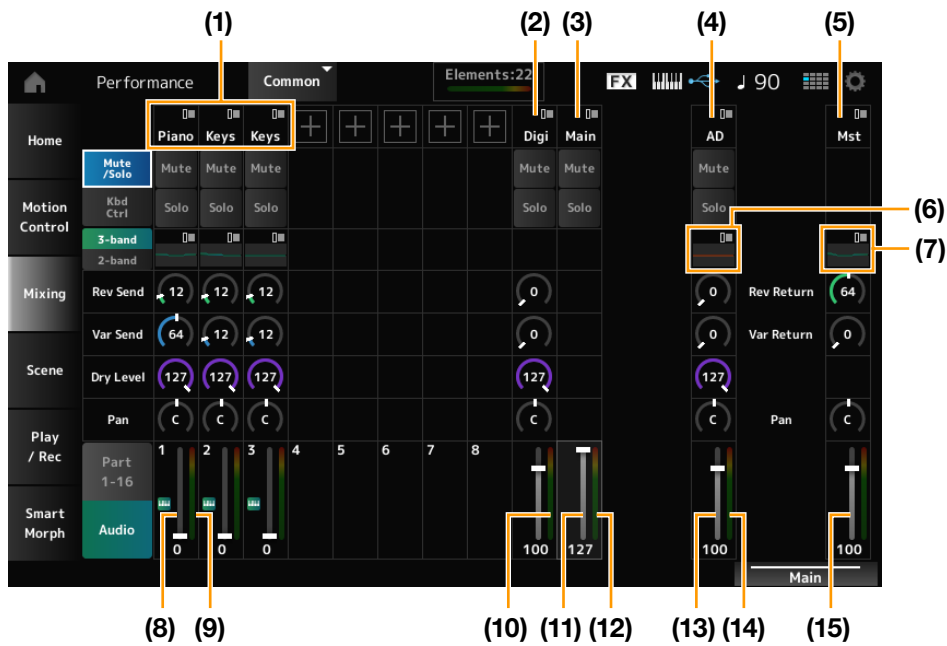

(1) Part Category

(6) A/D Part EQ

(11) USB Main Monitor Volume

(2) Digi (Digital Part)

(7) Master EQ

(12) Main (USB Main Monitor Level Meter)

(3) Main (USB Main Part)

(8) Digital Part Volume

(4) AD (A/D Part)

(9) Part Level Meter

(13) A/D Part Volume

(5) Mst (Master)

(10) Digi (Digital Part Level Meter)

(14) AD (A/D Part Level Meter)

(15) Performance Volume

Part Category

The Main category of the selected Part is shown.

Tap to display the context menu for Category Search, Edit, Property, etc.

When a Part other than Part 1 is selected and the sound is already set for that Part, the context menu for Category Search, Edit, Copy, and Delete is displayed. Tap [+] to add a Part.

Settings: Refer to the Data List

Digi (Digital Part)

Main (USB Main Part)

AD (A/D Part)

Mst (Master)

Tap to display the context menu for Edit, etc.

Mute/Solo Switch

Kbd Ctrl Switch

Switches between the Mute/Solo view and Keyboard Control view.

Mute (Part Mute)**Solo (Part Solo)**

Switches Mute and Solo for the Part on or off.

Settings: Off, On

A/D Part EQ

Tapping on the area calls up the context menu of Part EQ.

Digital Part Reverb Send**A/D Part Reverb Send**

Sets the level of the signals sent from the A/D Part or Digital Part to the Reverb Effect.

Settings: 0–127

Digital Part Variation Send**A/D Part Variation Send**

Sets the level of the signals sent from the A/D Part or Digital Part to the Variation Effect.

Settings: 0–127

Digital Part Dry Level**A/D Part Dry Level**

Sets the dry level (or the level of the signals without the System Effect) of the Digital Part or A/D Part.

Settings: 0–127

Digital Part Pan**A/D Part Pan**

Adjusts the Pan position (in the stereo field) of the Digital Part or A/D Part.

Settings: L63–C (center)–R63

Digital Part Volume**A/D Part Volume****USB Main Monitor Volume**

Sets the volume for the Audio Part.

Settings: 0–127

Master EQ

Shows the 5-band parametric EQ.

Tapping on the area calls up the context menu for Master EQ Edit.

Rev Return (Reverb Return)**Var Return (Variation Return)**

Sets the output level (Return Level) of the signals processed by the Reverb or Variation Effect.

Settings: 0–127

Rev Send (Reverb Send)

Sets the level of the signals sent to the Reverb Effect.

Settings: 0–127

Var Send (Variation Send)

Sets the level of the signals sent to the Variation Effect.

Settings: 0–127

Pan (Performance Pan)

Sets the Pan position (in the stereo field) of the Performance.

This parameter value offsets the Pan setting for each Part.

Settings: L63–C (center)–R63

Performance Volume

Sets the volume for the Performance.

Settings: 0–127

Part Level Meter

Digi (Digital Part Level Meter)

Main (USB Main Monitor Level Meter)

AD (A/D Part Level Meter)

Shows the level of Parts 1 to 8 and Audio Part.

Scene

On the Scene screen, you can register the settings for the Arpeggio type, Motion Sequence type, and Part parameters to each of the SCENE buttons.

On this screen, set the appropriate Memory (Memory Switch) On, and edit the desired parameter values so that you can save the settings to the Scene.

NOTE

The Scene function can be set from a screen other than Scene. You can change the assigned Scene parameters by moving the corresponding knobs and sliders and registering the settings by simultaneously holding down the [SHIFT] button and pressing the desired SCENE button.

Operation

[PERFORMANCE (HOME)] → Scene

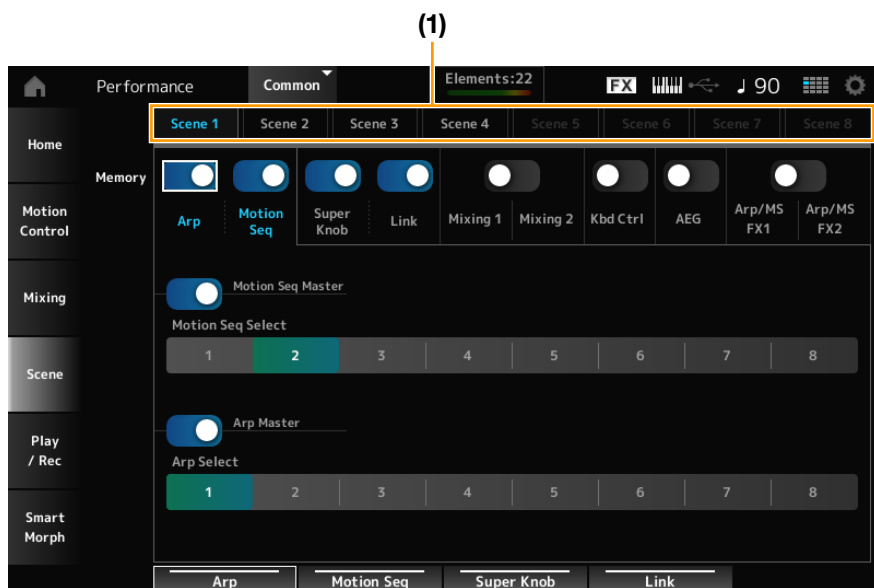

(1) Scene Select

Scene Select

Select a Scene tab to register the settings.

The Scene1 to Scene8 tabs are linked to the SCENE buttons on the top panel.

Settings: 1–8

Memory (Memory Switch)

Selects each of the parameter values such as Arpeggio, Motion Sequencer, Super knob, Super knob link, Mixing, Keyboard Control, Amplitude EG, and Arp/MS FX to register to the Scene.

When these switches are set to Off, the parameter values will not be shown on the display even when the corresponding tabs are selected.

Settings: Off, On

Part 1–16 / Common

Switches the view between Part1-16 and Common.

Shown on the Mixing 1, Mixing 2, Kbd Ctrl, AEG, Arp/MS FX1, and Arp/MS FX2 tabs.

Offset (Scene Mixing / AEG Value Mode Switch)

By setting Offset to Off, some Scene parameters can be finely-adjusted.

Shown on the Mixing 1, Mixing 2, and AEG tabs.

Settings: Off (Absolute), On (Offset)

When the Memory Switch for Arp and Motion Seq are set to On

Motion Seq Master (Motion Sequencer Master Switch)

Sets the Motion Sequencer on or off for the entire Performance.

Settings: Off, On

Motion Seq Select (Motion Sequence Select)

Changes the Motion Sequence Selection.

Settings: 1–8

Arp Master (Arpeggio Master Switch)

Sets the Arpeggio on or off for the entire Performance.

Settings: Off, On

Arp Select (Arpeggio Select)

Changes the Arpeggio selection.

Settings: 1–8

When the Memory Switch for Super Knob and Link are set to On



Super Knob (Super Knob Value)

Sets the Super Knob value.

Settings: 0–1023

Super Knob Link

Sets the link between the Super Knob and Assignable Knob 1–8 on or off.

When this switch is set to Off, operation of the Super Knob will not affect the parameters of the Assignable Knob.

Settings: Off, On

When the Memory Switch for Mixing 1 and Mixing 2 are set to On

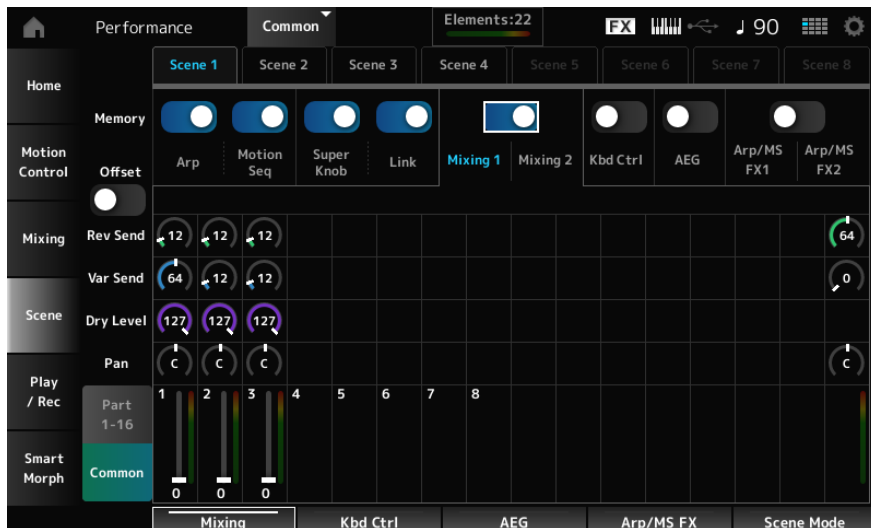

■ Mixing 1

Part 1–16 View: Scene parameters for Part 1–16 are shown.

Common View: Scene parameters for Part 1–8 and Common are shown.

Common parameters are applied to the entire Performance.

• Part 1–16 View

Rev Send (Reverb Send)

Sets the Reverb Send for each Part.

Settings: 0–127

Var Send (Variation Send)

Sets the Variation Send for each Part.

Settings: 0–127

Dry Level

Sets the Dry Level of each Part.

Settings: 0–127

Pan

Adjusts the Pan position (in the stereo field) for each Part.

Settings: L63–C (center)–R63

Volume (Part Volume)

Sets the Volume for each Part.

Settings: 0–127

• Common View

Rev Return (Reverb Return)

Sets the Reverb Return.

Settings: 0–127

Var Return (Variation Return)

Sets the Variation Return.

Settings: 0–127

Pan (Performance Pan)

Adjusts the Pan position (in the stereo field) of the Performance.

Settings: L63–C (center)–R63

■ Mixing 2

• Part 1-16 View

When Offset is set to On

Cutoff (Filter Cutoff Frequency)

Sets the cutoff frequency for each Part.

Settings: -64--+0--+63

Res (Filter Resonance/Width)

Sets the filter resonance or filter width for each Part.

Settings: -64--+0--+63

FEG Depth

Sets the FEG depth for each Part.

Settings: -64--+0--+63

When Offset is set to Off

By setting Offset to Off, some Scene parameters can be finely-adjusted.

Cutoff

Settings: (AN-X, FM-X): 0-1023

Res

Settings: (AN-X): 0-255

Settings: (FM-X): 0-127

FEG Depth

Settings: (AN-X): -9600--+0--+9600

Settings: (FM-X): -64--+0--+63

NOTE

It is recommended to set Offset to On when you wish to use both Smart Morph and Scene.

Mute (Part Mute)

Switches Mute for the Part on or off.

Settings: Off, On

Volume (Part Volume)

Sets the volume for the Part.

Settings: 0-127

• Common View

Cutoff (Cutoff Frequency)

Sets the offset value for the cutoff frequency of the Part.

Settings: -64--+0--+63

Res (Filter Resonance/Width)

Sets the offset value for the filter resonance or filter width of the Part.

Settings: -64--+0--+63

FEG Depth

This is specified as an offset value to the Part FEG Depth.

Settings: -64--+0--+63

When the Kbd Ctrl Memory Switch is set to On

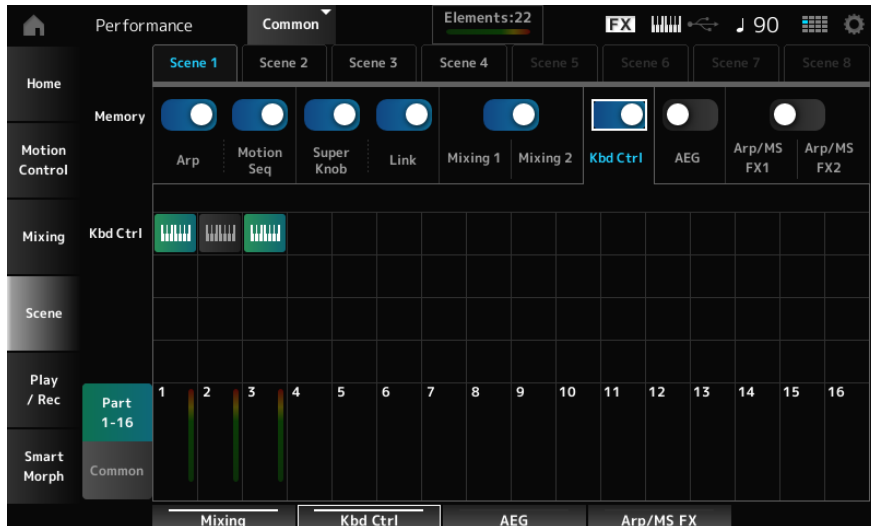

Kbd Ctrl (Part Keyboard Control Switch)

Switches Keyboard Control for the Part on or off.

When Keyboard Control for the Part is set to Off, no sound will be produced when you play the keyboard.

Settings: Off (gray), On (green)

When the AEG Memory Switch is set to On

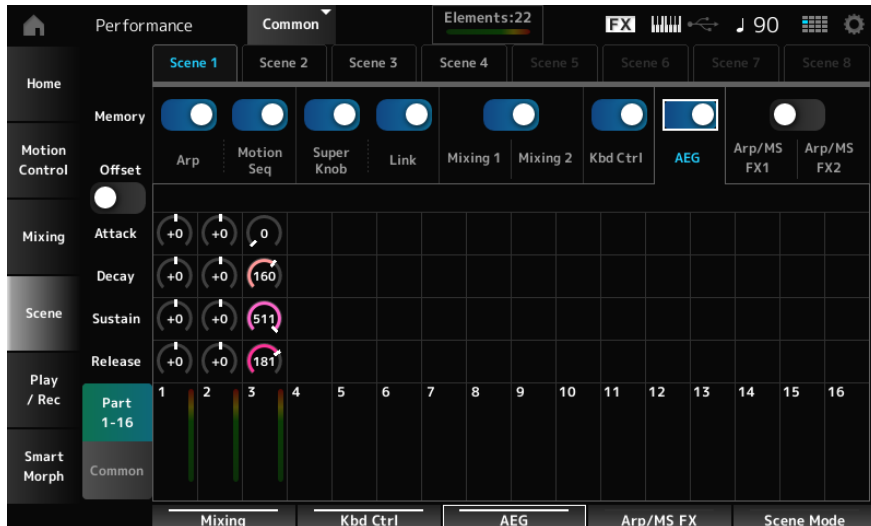

• Part 1-16 View

When Offset is set to On

Attack (AEG Attack Time)

Sets the AEG attack time for the Part.

Settings: -64--+0--+63

Decay (AEG Decay Time)

Sets the AEG decay time for the Part.

Settings: -64--+0--+63

Sustain (AEG Sustain Level)

Sets the AEG sustain level for the Part.

Settings: -64--+0--+63

Release (AEG Release Time)

Sets the AEG release time for the Part.

Settings: -64--+0--+63

When Offset is set to Off

By setting Offset to Off, some Scene parameters can be finely-adjusted.

Attack

Settings: (AN-X): 0-255

Decay

Settings: (AN-X): 0-255

Sustain

Settings: (AN-X): 0-511

Release

Settings: (AN-X): 0-255

• Common View

Attack

Sets the offset value to Attack (AEG Attack Time) for the Part.

Settings: -64--+0--+63

Decay

Sets the offset value to Decay (AEG Decay Time) for the Part.

Settings: -64--+0--+63

Sustain

Sets the offset value to Sustain (AEG Sustain Level) for the Part.

Settings: -64--+0--+63

Release

Sets the offset value to Release (AEG Release Time) for the Part.

Settings: -64--+0--+63

When the Memory Switch for Arp/MS FX 1 and Arp/MS FX 2 are set to On

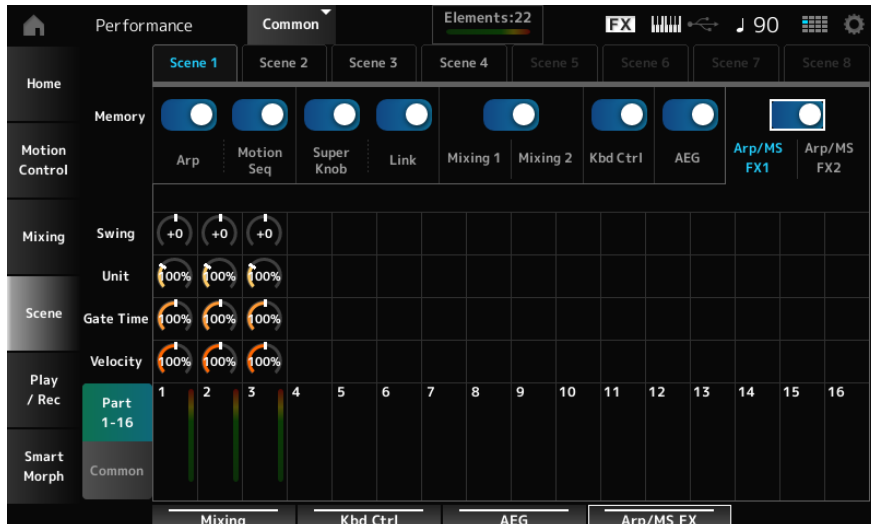

■ Arp/MS FX 1

• Part 1-16 View

Swing

Sets the swing value of the Arpeggio or Motion Sequencer for each Part.

Settings: -120+0+120

Unit (Part Unit Multiply)

Sets the percentage for stretching or compressing the playback time of the Arpeggio or Motion Sequencer for each Part.

Settings: 50%–400%, Common

200%: The playback time is doubled, and the tempo is halved

100%: The playback time is kept unchanged

50%: The playback time is halved, and the tempo is doubled

Common: The value set in the Unit (Common Unit Multiply) common to all Parts is applied

Gate Time (Arp Gate Time Rate)

Sets the Arpeggio gate time rate for each Part.

Settings: 0%–200%

Velocity (Arp Velocity Rate)

Sets the Arpeggio velocity rate for each Part.

Settings: 0%–200%

• Common View

Swing

Sets the offset value to Swing for each Part.

Settings: -120+0+120

Unit (Common Unit Multiply)

Sets the Unit Multiply for all Parts.

Settings: 50%–400%

200%: The playback time is doubled, and the tempo is halved

100%: The playback time is kept unchanged

50%: The playback time is halved, and the tempo is doubled

Gate Time (Arp Gate Time Rate)

Sets the offset value to Arpeggio Gate Time Rate for each Part.

Settings: -100+0+100

Velocity (Arp Velocity Rate)

Sets the offset value to Arpeggio Velocity Rate for each Part.

Settings: -100+0+100

■ **Arp/MS FX 2**

• **Part 1-16 View**

Amp (Motion Sequencer Amplitude Part Offset)

Sets the offset value to Motion Sequencer Amplitude for each Part.

Settings: -127--+0--+127

Shape (Motion Sequencer Pulse Shape Part Offset)

Sets the offset value to Motion Sequencer Pulse Shape for each Part.

Settings: -100--+0--+100

Smooth (Motion Sequencer Smoothness Part Offset)

Sets the offset value to Motion Sequencer Smoothness for each Part.

Settings: -127--+0--+127

Random (Motion Sequencer Randomness)

Sets the offset value to Motion Sequencer Randomness for each Part.

Settings: 0-127

• **Common View**

Amp (Motion Sequencer Amplitude Performance Offset)

Sets the offset value to Motion Sequencer Amplitude for all Parts.

Settings: -127--+0--+127

Shape (Motion Sequencer Pulse Shape Performance Offset)

Sets the offset value to Motion Sequencer Pulse Shape for all Parts.

Settings: -100--+0--+100

Smooth (Motion Sequencer Smoothness Performance Offset)

Sets the offset value to Motion Sequencer Smoothness for all Parts.

Settings: -127--+0--+127

Random (Motion Sequencer Randomness Performance Offset)

Sets the offset value to Motion Sequencer Randomness for all Parts.

Settings: -127--+0--+127

Play/Rec

On the Play/Rec screen, you can record Patterns and Songs to the Internal memory of this instrument, and Audio to a USB flash drive, and play back your recordings.

Pattern

■ Playback and playback standby

Operation

[SONG/PATTERN] button → Pattern

[PERFORMANCE (HOME)] → Play/Rec → Pattern

[▶] (Play) button → Pattern

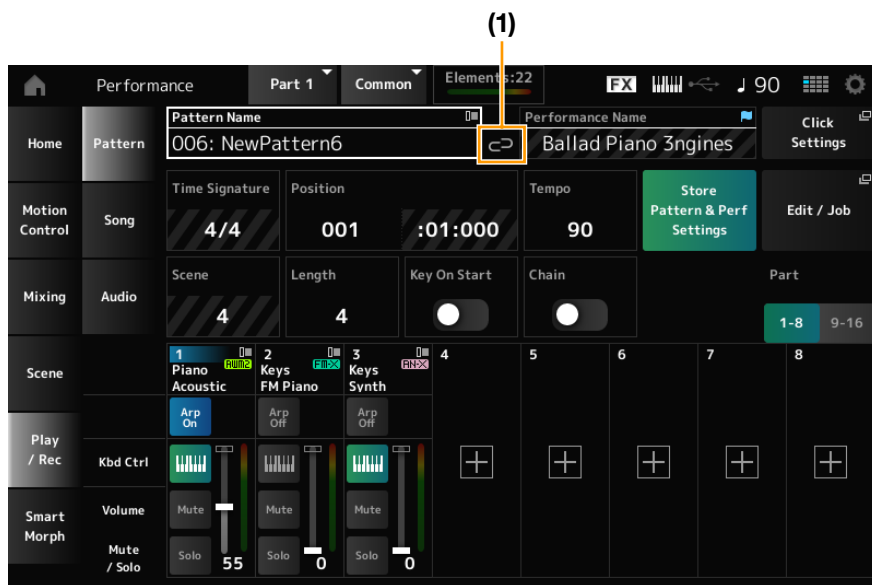

(1) Link Icon

Pattern Name

Shows the name of the selected Pattern.

Tap to display the context menu for Load, Rename, and New Pattern.

You can select a Pattern by using the [INC/YES] and [DEC/NO] buttons when the cursor is on the Pattern Name.

Link Icon

The Link Icon is shown if the Performance used for recording the Pattern and the selected Performance are the same. If not, a broken Link Icon will be shown.

Performance Name

Shows the name of the selected Performance.

NOTE

The blue flag will be shown at the top right of the Performance Name when you change a parameter in the Performance.

Click Settings

Opens the Tempo Settings screen.

Time Signature

Shows the meter for the Pattern.

Position

Sets the position for starting playback and recording, as well as the current playback position.

The number shown on the left is the measure, and the numbers shown on the right are the beats and ticks.

Tempo

Sets the tempo for Pattern playback.

Settings: 5–300

Store Pattern & Perf Settings (Store Pattern and Performance Settings)

Saves the link between the edited Patterns and the Performance used.

NOTE

If you have edited the Performance parameters, you will also need to store the Performance.

Edit/Job

Opens the screen for Pattern edit and jobs. By using the Pattern function, you can register a sequence for each Scene.

Scene

Shows the selected Scene number.

This switch is linked to the SCENE buttons on the top panel.

Length (Section Length)

Sets the sequence length of the selected Scene.

Settings: 1–256

Key On Start

Sets the Pattern to start recording or playback the moment you press a key on the keyboard.

Settings: Off, On

Chain

Enables chain playback.

Settings: Off, On

Undo ***

Cancels the previous action and returns to the previous state.

This button becomes available when one or more Jobs have been used after a sequence has been recorded.

Redo ***

Restores the action canceled using Undo. This button is only active after Undo *** has been used.

Part 1–8**Part 9–16**

Switches between Part views

■ Recording standby

Operation

[SONG/PATTERN] button → Pattern → [●] (Record) button

[PERFORMANCE (HOME)] → Play/Rec → Pattern → [●] (Record) button

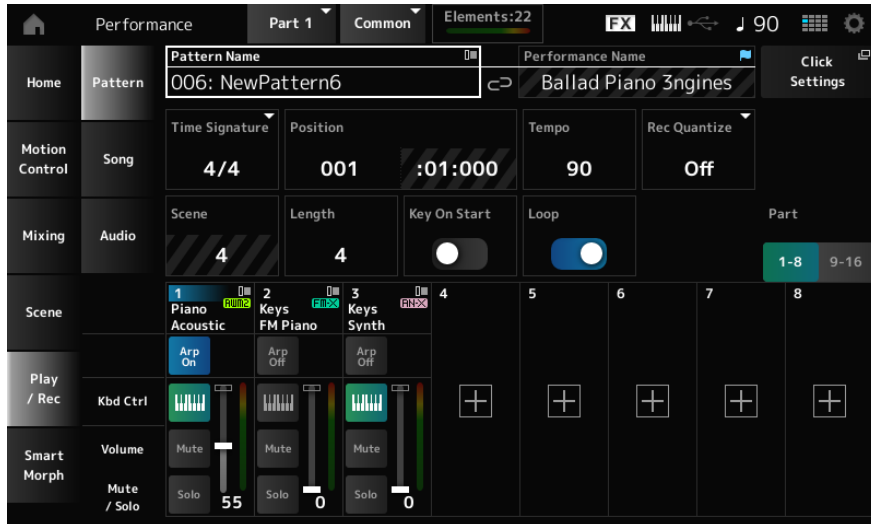

Time Signature

Sets the meter of the Scene.

Settings: 1/16–16/16, 1/8–16/8, 1/4–8/4

Rec Quantize (Record Quantize)

Quantize is a function that corrects the recorded notes to be on the exact fraction of the beat (in note values).

Settings: Off, 60 (thirty-second note), 80 (sixteenth note triplet), 120 (sixteenth note), 160 (eighth note triplet), 240 (eighth note), 320 (quarter note triplet), 480 (quarter note)

Loop

When set to On, Pattern recording continues in a loop.

Settings: Off, On

NOTE

Pressing the [●] (Record) button during Song recording sets the recorder to Rehearsal mode and makes the [●] (Record) button flash. In Rehearsal mode, playback of the Pattern continues but recording is temporarily paused, making it useful for practicing. You can return to Recording mode by pressing the [●] button again.

■ Recording

Operation

[SONG/PATTERN] button → Pattern → [●] (Record) button → [▶] (Play) button

[PERFORMANCE (HOME)] → Play/Rec → Pattern → [●] (Record) button → [▶] (Play) button

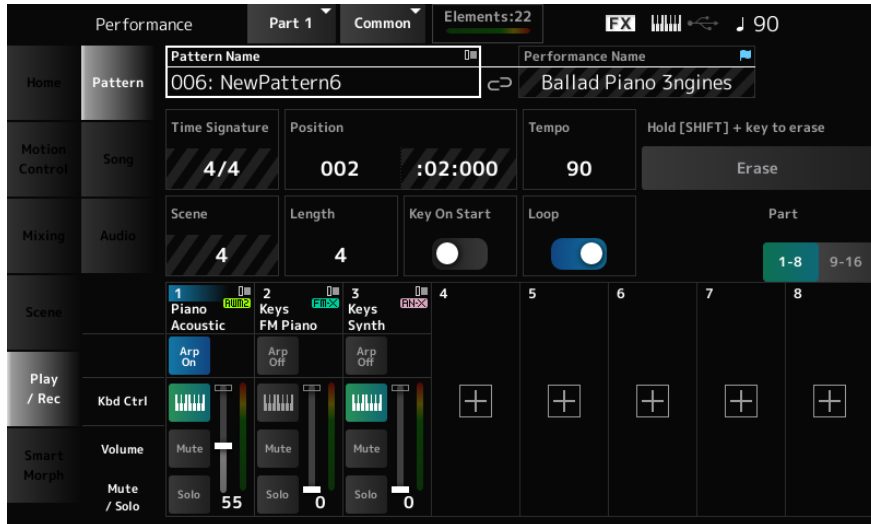

Hold [SHIFT] + key to erase

Erase

You can delete specific note events by holding down the [SHIFT] button and pressing the key corresponding to the note you wish to delete.

Alternately, you can tap on the Erase button on the screen to turn on the function, and then press the corresponding key on the keyboard to delete the note event.

■ Overdub recording

When you operate a controller during overdub recording, you can delete the existing events of that controller and record the operation as new events.

Operation

[PERFORMANCE (HOME)] → Play/Rec → Pattern → (with the Song already recorded) → [●] (Record) button → Tap Record Type → Select Overdub from the menu → [▶] (Play) button



Record Type

Selects from Replace or Overdub recording.

Settings: Replace, Overdub

Pattern Edit Overview

Operation

[▶] (Play) button → Pattern → [EDIT/↺↻] → Overview

[PERFORMANCE (HOME)] → Play/Rec → Pattern → Edit/Job → Overview

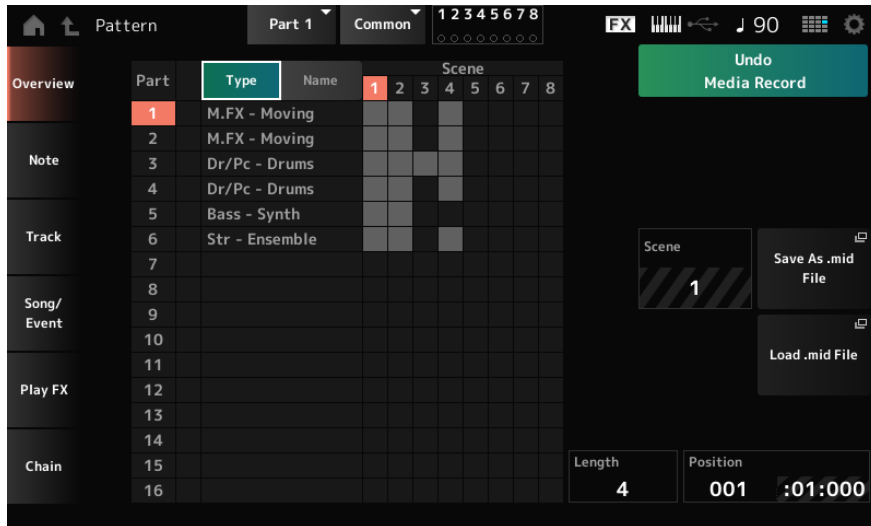

Type

Tap this button to see the Main and Sub categories of the Part. It also changes the list shown on the Play/Rec screen.

Name

Tap to see the Part Name. It also changes the list shown on the Play/Rec screen.

Part Mute Icon

Part Solo Icon

Shows the status of mute and solo settings for the Part.

Undo ***

Cancels the previous action and returns to the previous state.

This button becomes available when one or more Jobs have been used after a sequence has been recorded. Common operations for all tabs on the Pattern Edit screen.

Redo ***

Restores the recording that has been canceled by Undo. This button is only active after Undo *** has been used. Common operations for all tabs on the Pattern Edit screen.

Scene

Shows the selected Scene number.

Save As .mid File

Opens the Save screen. You can save the sequence of the selected Scene as a MIDI file.

Load .mid File

Opens the Load screen for loading a MIDI file.

After you have selected a MIDI file, select a Pattern and Scene in the load location.

Length

Sets the sequence length of the selected Scene.

Position

Shows the current position for the Scene playback, and lets you specify the playback position.

Settings: 001–256

Pattern Edit Note

■ Quantize

Quantization is the process of adjusting the timing of note events by moving them closer to the nearest exact beat. You can use this feature, for example, to improve the timing of a Pattern you have recorded in real time.

Operation

[▶] (Play) button → Pattern → [EDIT/↺] → Note → Quantize

[PERFORMANCE (HOME)] → Play/Rec → Pattern → Edit/Job → Note → Quantize

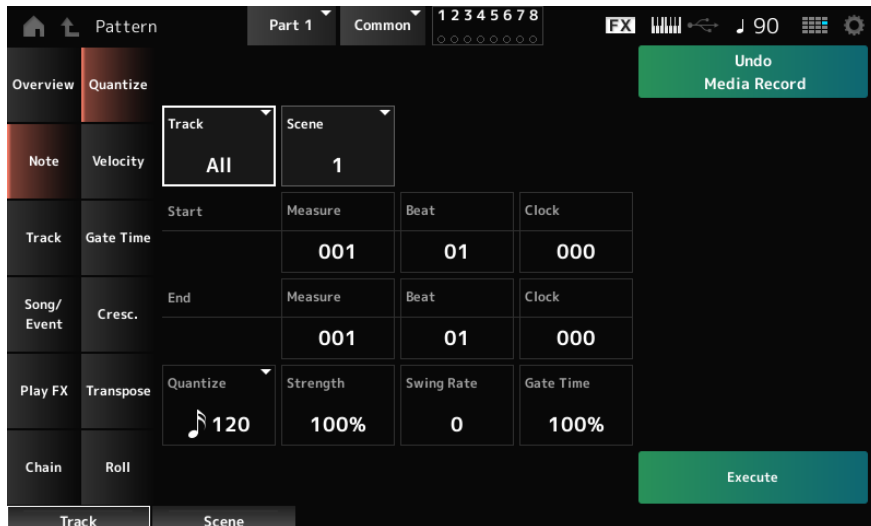

Track

Specifies the track for the job.

Settings: All, 1–16

Scene

Specifies the Scene for the job.

Settings: 1–8

Start Measure

Specifies the starting measure position for the job.

Settings: 001–257

Start Beat

Specifies the starting beat position for the job.

Settings: Depends on the Time Signature setting

Start Clock

Specifies the starting clock position for the job.

Settings: Depends on the Time Signature setting

End Measure

Specifies the ending measure position for the job.

Settings: 001–257

End Beat

Specifies the ending beat position for the job.

Settings: Depends on the Time Signature setting

End Clock

Specifies the ending clock position for the job.

Settings: Depends on the Time Signature setting

Quantize

Sets the quantization resolution (or a note to be used as a base for the quantization).

Settings: Thirty-second note, sixteenth note triplet, sixteenth note, eighth note triplet, eighth note, quarter note triplet, quarter note, sixteenth note + sixteenth note triplet, eighth note + eighth note triplet

Strength

Sets the “magnetic strength” of the quantization.

When this parameter is set to 100%, all notes will move to the position specified in Quantize while a setting of 0% results in no quantization.

Settings: 0%–100%

Swing Rate

Changes the timing of the even-numbered beats (backbeats) counted from the value specified in Quantize to add a swing feel to the rhythms.

Settings: Depends on the Quantize (quantization resolution) setting.

When Quantize is set to quarter note, eighth note, sixteenth note, or thirty-second note: 0 to half the grid

When Quantize is set to quarter note triplet, eighth note triplet, or sixteenth note triplet: 0 to half the grid

When Quantize is set to eighth note + eighth note triplet, or sixteenth note + sixteenth note triplet: 0 to half the triplet grid

Gate Time

Changes the gate time (or the actual time for the note to be played) of the even-numbered beats (backbeats) counted from the value specified in Quantize to add a swing feel to the rhythms.

Settings: 0%–200%

Execute

Carries out the selected Job to the MIDI sequence. Common operations for all tabs on the Pattern Edit screen.

■ Velocity

Changes the sound strength (velocity) of the notes in the specified range.

NOTE

Velocity is modified using the following formula

$$\text{Adjusted Velocity} = (\text{Original Velocity} \times \text{Rate}) + \text{Offset}$$

If the result is 0 or less, the value is set to 1. If the result is higher than 128, the value is set to 127.

Operation

[▶] (Play) button → Pattern → [EDIT/↺] → Note → Velocity

[PERFORMANCE (HOME)] → Play/Rec → Pattern → Edit/Job → Note → Velocity

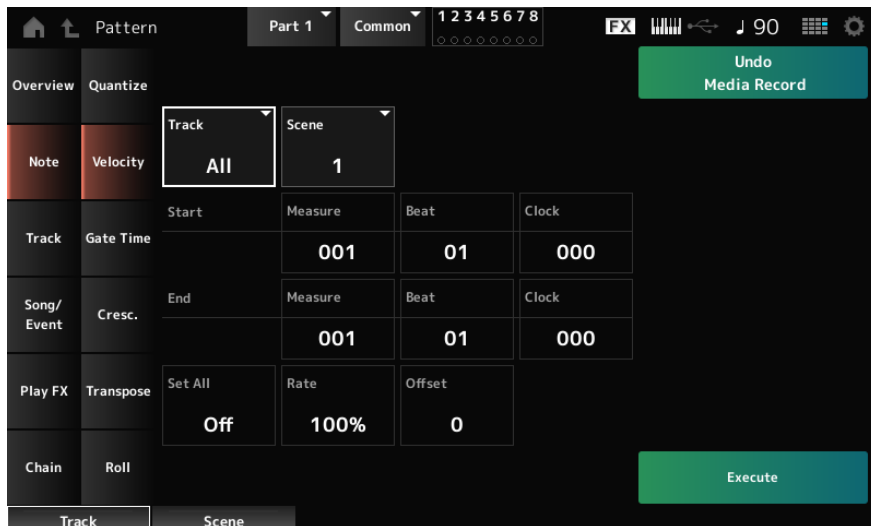

Set All

Sets the velocity of all notes in the selected section.

When set to Off, Set All will not work.

When set to anything other than Off, Rate and Offset will be disabled.

Settings: Off, 001–127

Rate

Sets the percentage for changing the velocity.

When set to 99% or lower, the velocity will be slower. When set to 101% or higher, the velocity will be faster. At 100% the velocity will be kept unchanged.

This parameter cannot be changed when Set All is set to anything other than Off.

Settings: 0%–200%

Offset

Sets the value to add to or subtract from the original Velocity value.

When set to –1 or smaller, the velocity will be slower. When set to +1 or larger, the velocity will be faster. When set to 0, the velocity will be kept unchanged.

This parameter cannot be changed when Set All is set to anything other than Off.

Settings: –127–0–+127

■ Gate Time

Changes the sound time (gate time) of the notes in the specified range.

NOTE

Gate time is modified using the following formula

Adjusted Gate Time = (Original Gate Time × Rate) + Offset

If the result is 0 or lower, the value is set to 1.

Operation

[▶] (Play) button → Pattern → [EDIT/↺] → Note → Gate Time

[PERFORMANCE (HOME)] → Play/Rec → Pattern → Edit/Job → Note → Gate Time

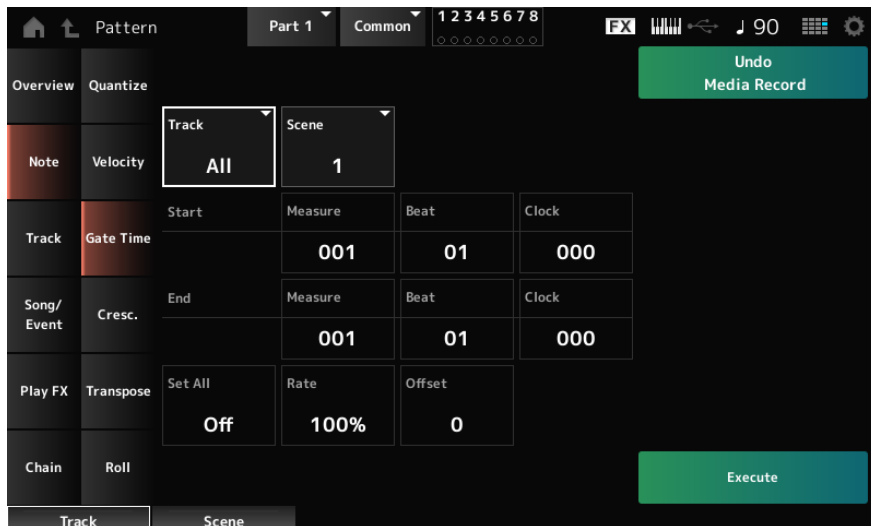

This is the same as Pattern Edit Note → Velocity, except that the Set All setting values are different.

Set All

Settings: Off, 001–9999

■ Cresc. (Crescendo)

Applies a gradual increase (crescendo) or decrease (deceleration) of the velocity of notes in the specified range

Operation

[▶] (Play) button → Pattern → [EDIT/↺↻] → Note → Cresc.

[PERFORMANCE (HOME)] → Play/Rec → Pattern → Edit/Job → Note → Cresc.

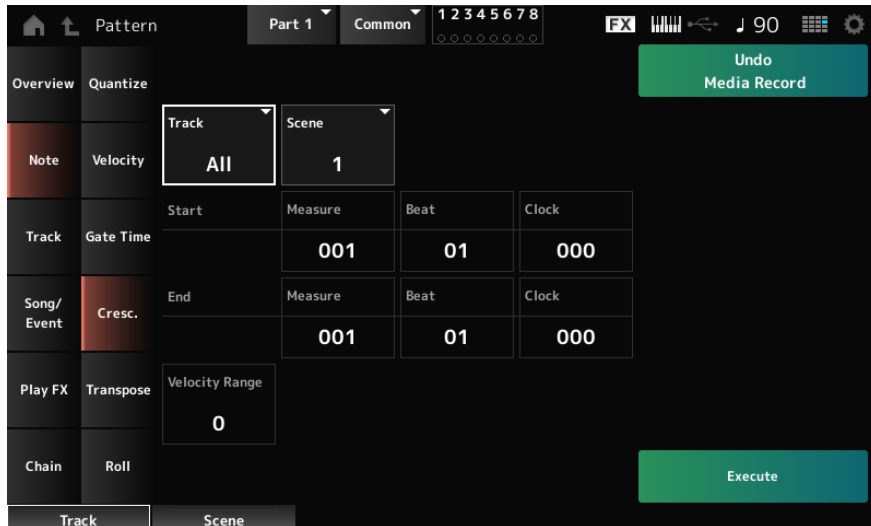

Velocity Range

Sets the intensity of the crescendo or deceleration.

Within the specified range, gradually increases or decreases the intermediate velocities so that the final velocity becomes the "Initial velocity value + Velocity Range value" based on the initial velocity. If the final velocity is 0 or lower, the final velocity is set to 1, and if it is 128 or higher, it is set to 127.

A positive value produces a crescendo, and a negative value produces a deceleration.

At 0, there is no velocity change.

Settings: -127-0-+127

■ Transpose

This Job lets you change the key or pitch of the notes in the specified range.

NOTE

When transposed, notes set in the range beyond C-2 to G8 are automatically moved to fit within C-2 to G8.

Operation

[▶] (Play) button → Pattern → [EDIT/↺] → Note → Transpose

[PERFORMANCE (HOME)] → Play/Rec → Pattern → Edit/Job → Note → Transpose

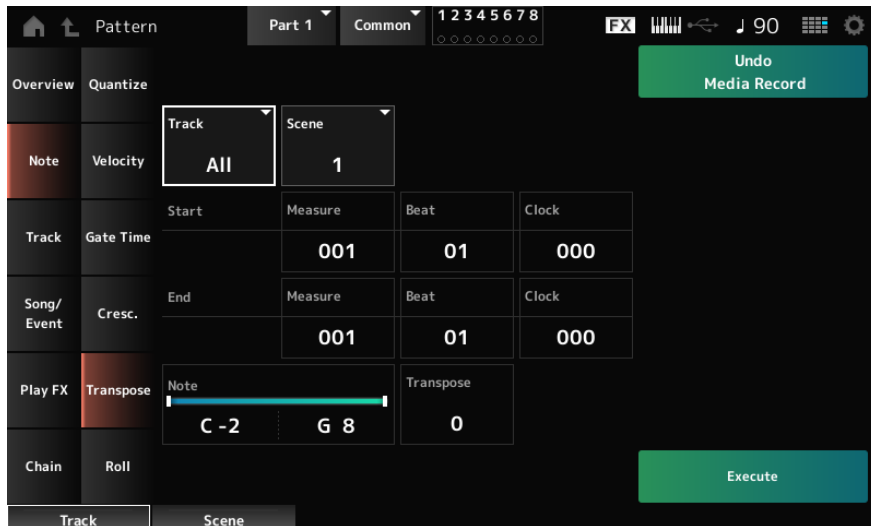

Note

Specifies the range of keys (notes) for transposing.

Tap to open the context menu and then set the Keyboard to On so that you can use the keys on the keyboard.

Settings: C-2-G8

Transpose

Sets the range of notes to shift in semitones.

A setting of +12 transposes up one octave, while a setting of -12 transposes down an octave. The value 0 produces no change.

Settings: -127-0-+127

■ Roll

This Job creates a series of repeated notes (like a drum roll) over the specified range.

Operation

[▶] (Play) button → Pattern → [EDIT/↺↻] → Note → Roll

[PERFORMANCE (HOME)] → Play/Rec → Pattern → Edit/Job → Note → Roll

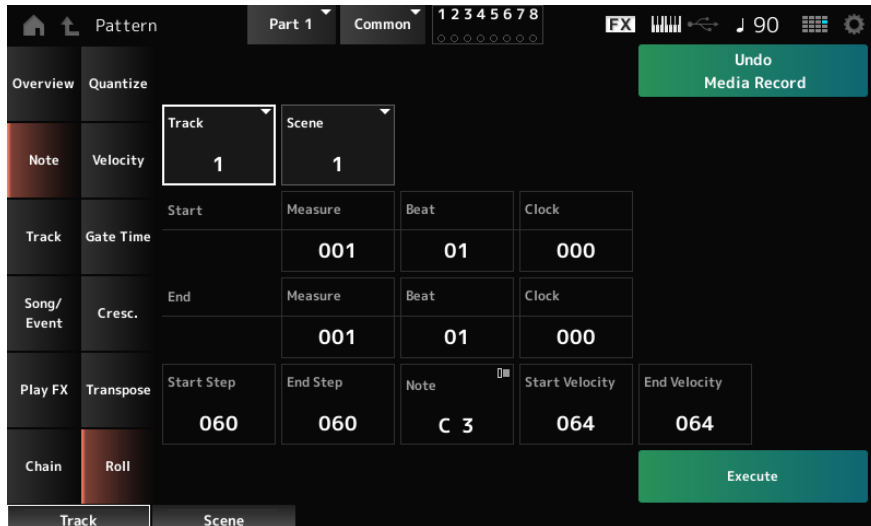

Track

Settings: 1–16

Start Step

Sets the size of the step (i.e., the number of clocks) between each note in the roll.

By setting a smaller value, you can play faster rolls. The clock specified here is for the beginning of the range.

Settings: 015–999

End Step

Sets the size of the step (i.e., the number of clocks) between each note in the roll.

By setting a smaller value, you can play faster rolls. The clock specified here is for the end of the range.

Settings: 015–999

Note

Sets the notes for rolls.

Tap to open the context menu and then set the Keyboard to On so that you can use the keys to set notes.

Settings: C–2–G8

Start Velocity

Sets the velocity for the strength of rolls. The velocity specified here is for the beginning of the range.

Settings: 001–127

End Velocity

Sets the velocity for the strength of rolls. The velocity specified here is for the end of the range.

Settings: 001–127

NOTE

By setting both Start Velocity and End Velocity, you can create crescendo or decrescendo for the rolls.

Pattern Edit Track

■ Copy/Exchange

This Job copies data from a specified source track to the specified destination track or exchanges data between two specified tracks.

Operation

[▶] (Play) button → Pattern → [EDIT/↺] → Track → Copy/Exchange

[PERFORMANCE (HOME)] → Play/Rec → Pattern → Edit/Job → Track → Copy/Exchange

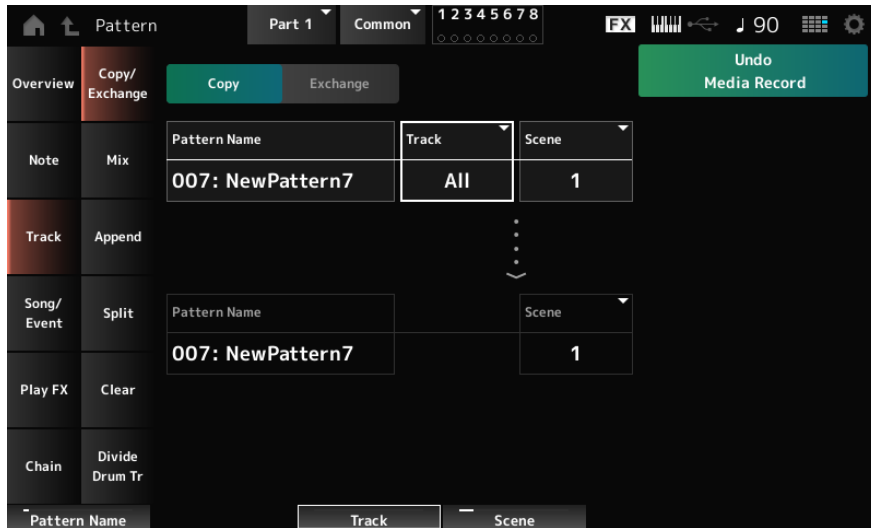

Copy

Copies data from the specified track to another track.

NOTICE

When Copy Track is carried out, the existing data on the destination track will be overwritten and lost.

Exchange

Exchanges data between two tracks.

Pattern Name *Source

Specifies the Pattern to copy from.

Track *Source

Specifies the track to copy from.

Settings: All, 1–16

Scene *Source

Specifies the Scene to copy from.

Settings: All, 1–8

Pattern Name *Destination

Specifies the Pattern to copy to.

Track *Destination

Specifies the track to copy to.

This parameter is not available when Source is set to All.

Settings: 1–16

Scene *Destination

Specifies the Scene to copy to.

This parameter is not available when Source is set to All.

Settings: 1–8

Copy Track

Executes a copy action.

NOTE

When Copy Track is carried out with the Track and Scene set to All, the Chain data will also be copied.

Exchange Track

Executes an exchange.

NOTE

When Exchange Track is carried out with the Track and Scene set to All, the Chain data will also be copied.

■ Mix

Mixes (merges) the data from the specified track A and track B and places the result in track B.

Operation

[▶] (Play) button → Pattern → [EDIT/↺↻] → Track → Mix

[PERFORMANCE (HOME)] → Play/Rec → Pattern → Edit/Job → Track → Mix

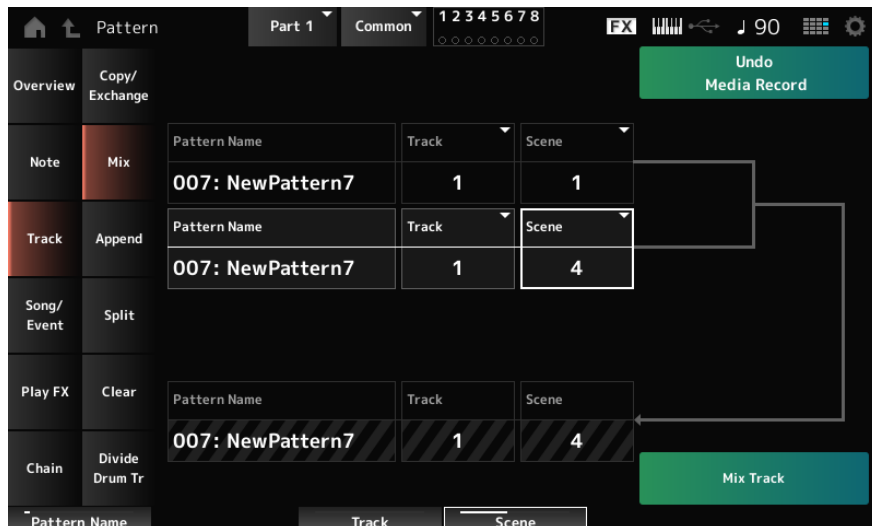

Pattern Name *Source A

Specifies the first Pattern to mix.

Track *Source A

Specifies the track for the job.

Settings: 1–16

Scene *Source A

Specifies the Scene for the job.

Settings: All, 1–8

Pattern Name *Source B

Specifies the first Pattern to mix.

Track *Source B

Specifies the track for the job.

Settings: 1–16

Scene *Source B

Specifies the Scene for the job.

This parameter is not available when Source A is set to All.

Settings: 1–8

Pattern Name *Destination B

Shows the name of the Pattern to mix to.

Track *Destination B

Shows the track number for the job.

Scene *Destination B

Shows the Scene number for the job.

This parameter is not available when Source A is set to All.

Mix Track

Executes a mix action.

■ Append

Adds the data in the specified track to the end of another track.

Operation

[▶] (Play) button → Pattern → [EDIT/↺↻] → Track → Append

[PERFORMANCE (HOME)] → Play/Rec → Pattern → Edit/Job → Track → Append

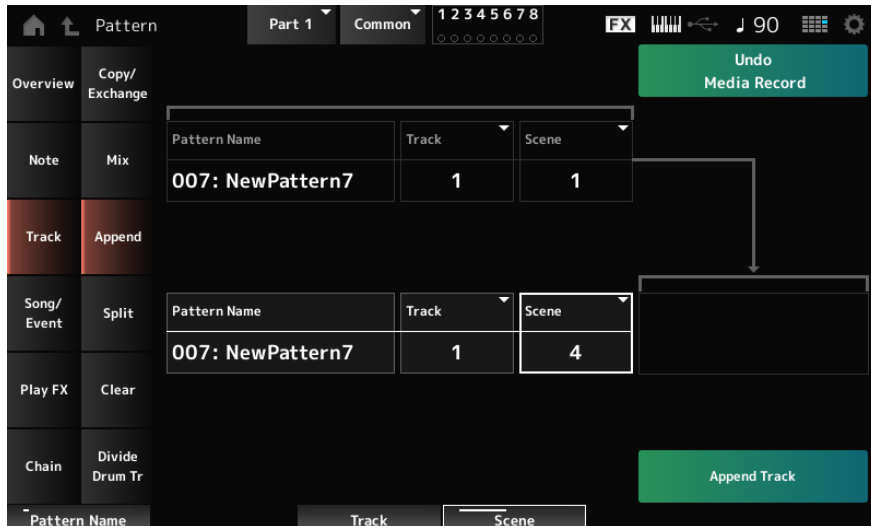

Pattern Name *Source

Specifies the Pattern to add from.

Track *Source

Sets the target track for the job.

Settings: All, 1–16

Scene *Source

Specifies the Scene for the job.

Settings: 1–8

Pattern Name *Destination

Specifies the Pattern to add to.

Track *Destination

Sets the target track for the job.

This parameter is not available when Source is set to All.

Settings: 1–16

Scene *Destination

Specifies the Scene for the job.

Settings: 1–8

Append Track

Executes an append action.

■ Split

Splits the data of the specified track at the specified measure and moves the second half to another specified track.

Operation

[▶] (Play) button → Pattern → [EDIT/↺↻] → Track → Split

[PERFORMANCE (HOME)] → Play/Rec → Pattern → Edit/Job → Track → Split

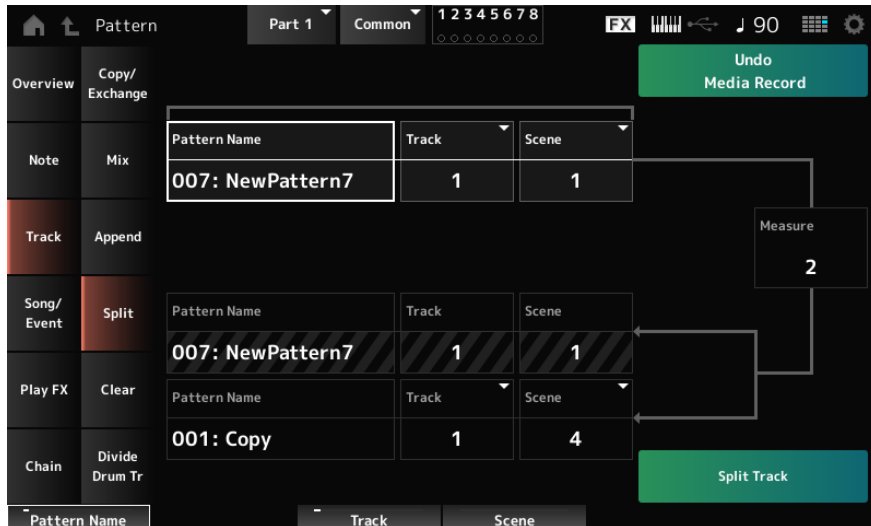

Pattern Name *Source

Specifies the Pattern to split.

Track *Source

Sets the target track for the job.

Settings: All, 1–16

Scene *Source

Sets the target scene for the job.

Settings: 1–8

Measure *Source

Specifies the measure at which the data is to be split.

Settings: 2–256

Pattern Name

Shows the Pattern to split into.

Track

Shows the track for the job.

Scene

Shows the Scene for the job.

Pattern Name *Destination

Specifies the Pattern to which the split data is to be sent.

Track *Destination

Sets the target track for the job.

This parameter is not available when Source is set to All.

Settings: 1–16

Scene *Destination

Sets the target scene for the job.

Settings: 1–8

Split Track

Executes a split action.

■ Clear

Deletes data of the specified track.

Operation

[▶] (Play) button → Pattern → [EDIT/↺↻] → Track → Clear

[PERFORMANCE (HOME)] → Play/Rec → Pattern → Edit/Job → Track → Clear

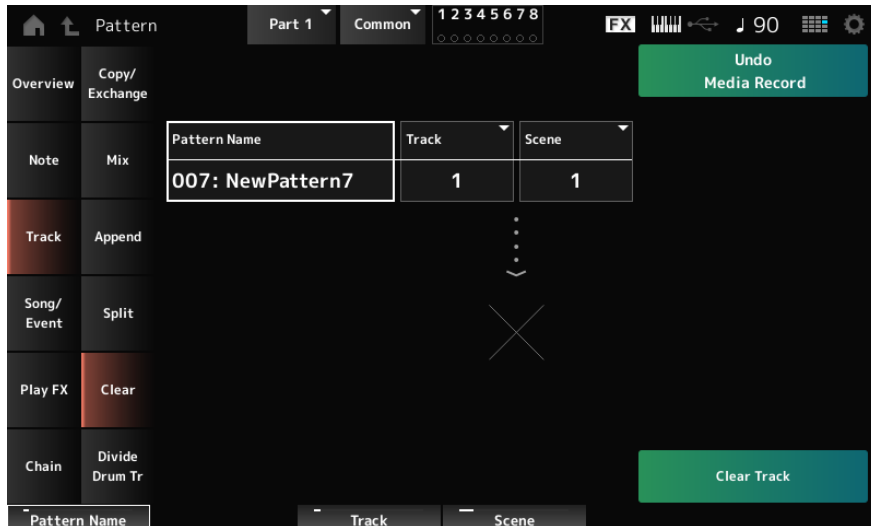

Pattern Name

Specifies the pattern to delete.

Track

Specifies the track for the job.

Settings: All, 1–16

Scene

Specifies the Scene for the job.

Settings: All, 1–8

Clear Track

Executes a clear action.

NOTE

When Clear Track is carried out with the Track and Scene set to All, the Chain data will also be deleted.

■ Divide Drum Tr (Divide Drum Track)

Takes the recorded drums from the specified track and assigns each Instrument (individual percussion instrument in the drum set) to Tracks 9 to 16.

NOTE

When there is existing data on Tracks 9 to 16 and Parts 9 to 16, carrying out the Divide Drum Track operation will overwrite the existing data. Undo and Redo cannot be used with this operation.

Operation

[▶] (Play) button → Pattern → [EDIT/↺] → Track → Divide Drum Tr

[PERFORMANCE (HOME)] → Play/Rec → Pattern → Edit/Job → Track → Divide Drum Tr

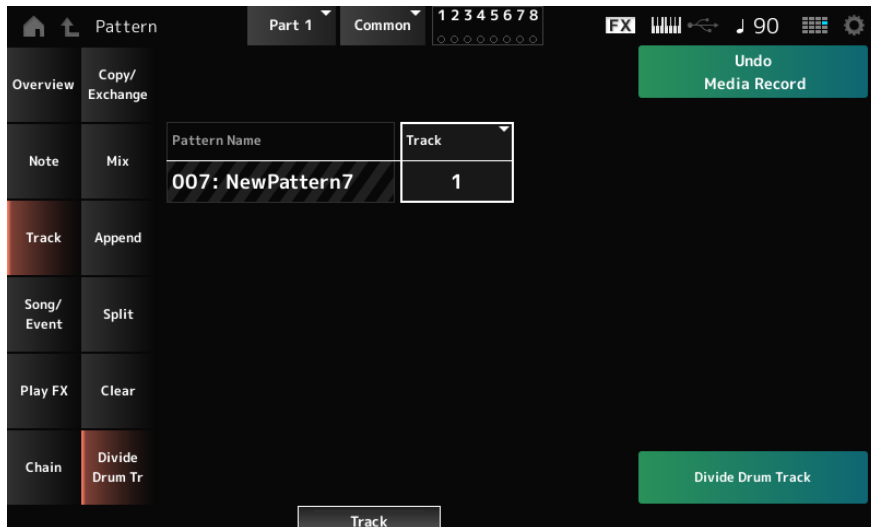

Pattern Name

Sets the target pattern for the job.

Track

Sets the target track for the job.

Settings: 1–16

Divide Drum Track

Executes a drum track divide action.

Pattern Edit Song/Event

■ Get Phrase

Copies a specific section of the Song to the specified track.

NOTICE

The data at the copy destination will be overwritten and lost.

Operation

[▶] (Play) button → Pattern → [EDIT/↺↻] → Song/Event → Get Phrase

[PERFORMANCE (HOME)] → Play/Rec → Pattern → Edit/Job → Song/Event → Get Phrase

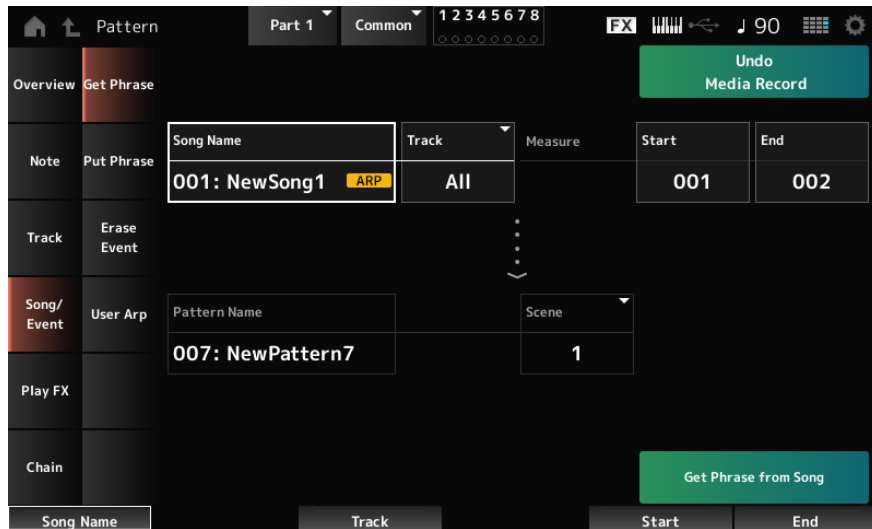

Song Name

Specifies the Song to copy from.

Track *Source

Sets the target track for the job.

Settings: All, 1–16

Start Measure

Sets the target starting measure for the job.

Settings: 001–998

End Measure

Sets the target ending measure for the job.

Settings: 002–999

Pattern Name

Specifies the Pattern to copy to.

Track *Destination

Specifies the track to copy to.

This parameter is not available when Source is set to All.

Settings: 1–16

Scene

Specifies the Scene to copy to.

Settings: 1–8

Get Phrase from Song

Copies a phrase.

■ Put Phrase

Copies the specified measures of the specified Pattern track to the specified Song track.

NOTE

The copied data will be merged into the existing data on the destination track.

Operation

[▶] (Play) button → Pattern → [EDIT/↺] → Song/Event → Put Phrase

[PERFORMANCE (HOME)] → Play/Rec → Pattern → Edit/Job → Song/Event → Put Phrase

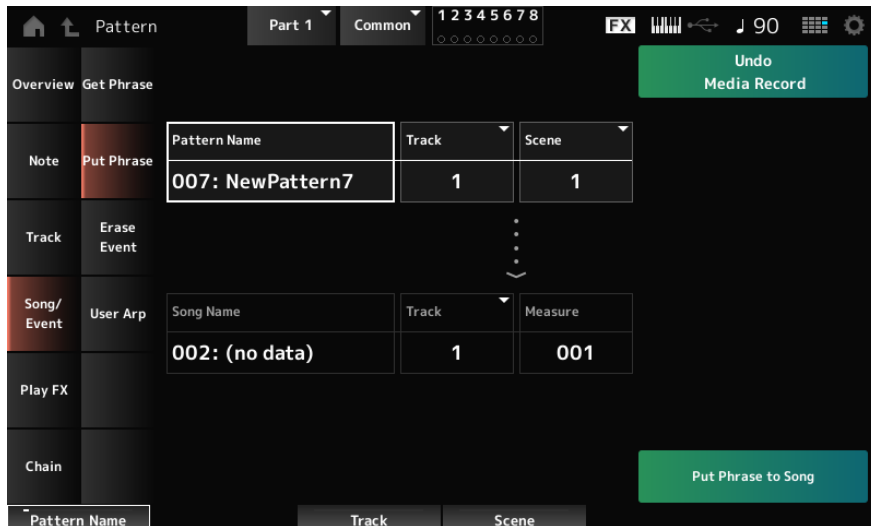

Pattern Name

Specifies the Pattern to copy from.

Track *Source

Sets the target track for the job.

Settings: 1–16

Scene

Sets the target scene for the job.

Settings: 1–8

Song Name

Specifies the Song to copy to.

Track *Destination

Sets the target track for the job.

Settings: 1–16

Measure

Specifies the measure to copy to.

Settings: 001–999

Put Phrase to Song

Copies a phrase.

■ Erase Event

Erases the event.

Operation

[▶] (Play) button → Pattern → [EDIT/↺] → Song/Event → Erase Event

[PERFORMANCE (HOME)] → Play/Rec → Pattern → Edit/Job → Song/Event → Erase Event

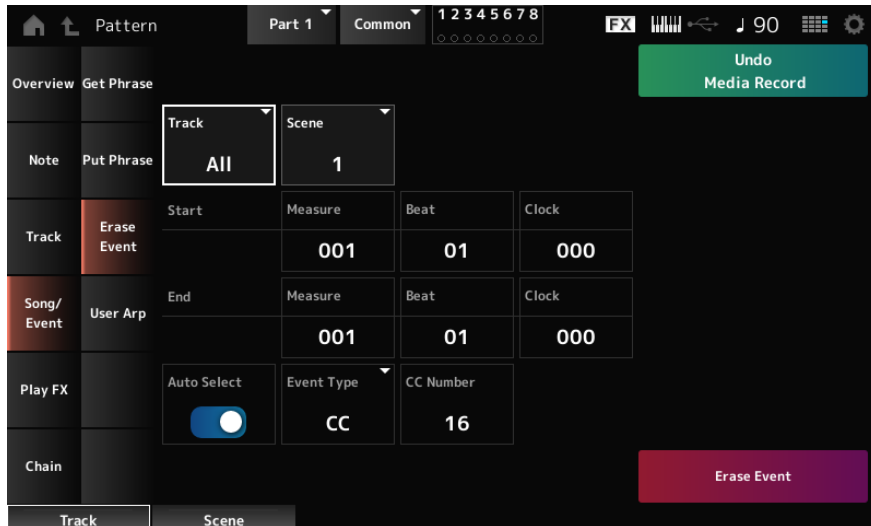

Many of the parameters are the same as Pattern Edit Note → Quantize.

Auto Select

Switches the Auto Select setting of the Event Type on or off.

When this is set to On, you can simply move the controller whose data you wish to erase, and the corresponding controller's event will automatically be set for Event Type.

Settings: Off, On

Event Type

Specifies the type of event you wish to erase.

Settings: Note, Poly, CC, NRPN, RPN, PC, AfterTouch, PitchBend, Superknob, SysEx, All

CC Number

Displayed when the Event Type is set to CC. Specify the Control Change number of the event to erase.

Settings: All, 1–127

Erase Event

Executes the event deletion.

■ User Arp (User Arpeggio)

Registers the data in the specified measures of the Scene as a User Arpeggio.

Operation

[▶] (Play) button → Pattern → [EDIT/↺] → Song/Event → User Arp

[PERFORMANCE (HOME)] → Play/Rec → Pattern → Edit/Job → Song/Event → User Arp

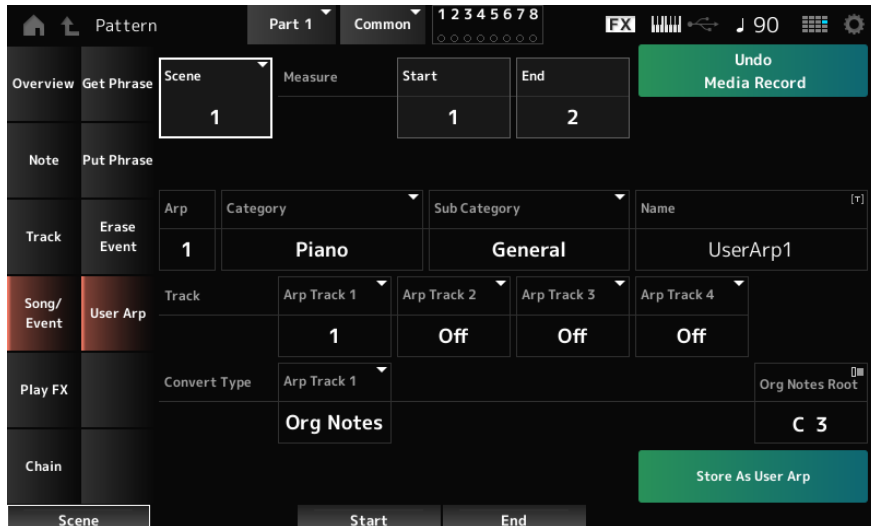

Scene

Specifies the Scene for the job.

Settings: 1–8

Start Measure

Specifies the starting measure position for the job.

Settings: 1–256

End Measure

Specifies the ending measure position for the job.

Settings: 2–257

Arp (Arp Number)

Sets the Arpeggio Number of the User Arpeggio for conversion.

Initially, the next unused number will be set.

Keep in mind that if you change this to a number already being used, the Arpeggio will be overwritten, meaning that you will lose the existing User Arpeggio for that number.

Settings: 1–256

Category (Arpeggio Category)

Sub Category (Arpeggio Sub Category)

Sets the Main and Sub categories of the converted Arpeggio.

Settings: Refer to the Data List

Name (Arpeggio Name)

Give the User Arpeggio a name. You can use up to 20 alphanumeric characters.

Track

Sets the track number to convert from for each Arpeggio track.

Settings: Off, 1–16

Convert Type

Select the method for converting MIDI sequence data recorded in the track into an arpeggio.

You can use a different Convert Type for each Arpeggio track.

Settings: Normal, Fixed, Org Notes

Normal: The Arpeggio is played back at the same octave as the recorded MIDI Sequence.

Fixed: The recorded MIDI sequence is played back the same way no matter how you play the keyboard.

Org Notes: Basically the same as Fixed, but the MIDI sequence changes according to the chords you play on the keyboard

Org Notes Root

Sets the root note when the Convert Type of any track is set to Org Notes.

This parameter is not available when no track is set to Org Notes.

Settings: C–2–G8

Store As User Arp (Store As User Arpeggio)

Converts the Pattern to a User Arpeggio using the settings on the screen.

This parameter is not available when all Track are set to Off.

Pattern Edit Play FX (Play Effects)

Applies effects to the MIDI sequence during Pattern playback. Sets the range and level of the effect for each parameter of the specified track.

Operation

[▶] (Play) button → Pattern → [EDIT/↺] → Play FX

[PERFORMANCE (HOME)] → Play/Rec → Pattern → Edit/Job → Play FX



■ Common

Track

Specifies the track to be normalized.

Settings: All, 1–16

Scene

Specifies the Scene to be normalized.

Settings: All, 1–8

Normalize Play FX

Fixes the effect specified in Play FX to the MIDI data.

Length

Sets the sequence length of the selected Scene.

Position

Shows the current position for the Scene playback, and lets you specify the playback position.

Settings: 001–256

■ Play FX1

Controls Qntz Value, Qntz Str, Swing Vel, Swing Gate, and Swing Rate.

Qntz Value (Quantize Value)

Sets the quantization resolution (or a note to be used as a base for the quantization).

Settings: Off, 60 (thirty-second note), 80 (sixteenth note triplet), 120 (sixteenth note), 160 (eighth note triplet), 240 (eighth note), 320 (quarter note triplet), 480 (quarter note)

Qntz Str (Quantize Strength)

Sets the “magnetic strength” of the quantization.

When this parameter is set to 100%, all notes will move to the position specified in Qntz Value (Quantize Value) while a setting of 0% results in no quantization.

Settings: 0%–100%

Swing Vel (Swing Velocity Rate)

Changes the velocity of the even-numbered beats (backbeats) counted from the value specified in Qntz Value (Quantize Value) to add a swing feel to the rhythms. This parameter is not available when Qntz Value (Quantize Value) is set to Off.

Settings: 0%–200%

Swing Gate (Swing Gate Time Rate)

Changes the gate time (or the actual time for the note to be played) of the even-numbered beats (backbeats) counted from the value specified in Qntz Value (Quantize Value) to add a swing feel to the rhythms. This parameter is not available when Qntz Value (Quantize Value) is set to Off.

Settings: 0%–200%

Swing Rate (Swing Offset)

Changes the timing of the even-numbered beats (backbeats) counted from the value specified in Qntz Value (Quantize Value) to add a swing feel to the rhythms. This parameter is not available when Qntz Value (Quantize Value) is set to Off.

Settings: 0 to half of Qntz Value (Quantize Value)

■ Play FX2

Controls Note Shift, Clock Shift, Gate Time, Velocity Rate, and Velocity Offset.



Note Shift

Adjusts the pitch in semitones.

Settings: -99+0+99

Clock Shift

Shifts the timing of the notes back or forward in clock increments.

Settings: -120+0+120

Gate Time

Changes the gate time (the actual time for the sound of the note to be generated) of the note events.

Settings: 0%–200%

Velocity Rate

Changes the velocity by the specified percentage.

Settings: 0%–200%

Velocity Offset

Increases or decreases velocity by the specified value.

Settings: -99+0+99

Pattern Edit Chain

This Job chains Scenes for playback.

Operation

[▶] (Play) button → Pattern → [EDIT/↺↻] → Chain

[PERFORMANCE (HOME)] → Play/Rec → Pattern → Edit/Job → Chain



Chain

Enables chain playback.

Settings: Off, On

Measure

Specifies the starting measure position for Scene playback.

Settings: 001–999

Scene

Sets the Scene to play back at the specified Measure.

Settings: 1–8, End

Page

When there are more than eight rows for the list of Measure and Scene, the up or down arrow will be shown.

Convert to Song

Saves the chain as a Song.

Length

Shows the length of the entire sequence.

Position

Shows the current position of chain playback, and lets you specify the playback position.

Settings: 001–999

Song

In the Song screen, you can record your keyboard performance in MIDI Song, and play back the Song. The data of both the keyboard performance and the operation of controllers and knobs is recorded to the MIDI track. You can also select Arpeggio playback to be recorded to the Song.

■ Playback and playback standby

Operation

[SONG/PATTERN] button → Song

[PERFORMANCE (HOME)] → Play/Rec → Song

[▶] (Play) button → Song

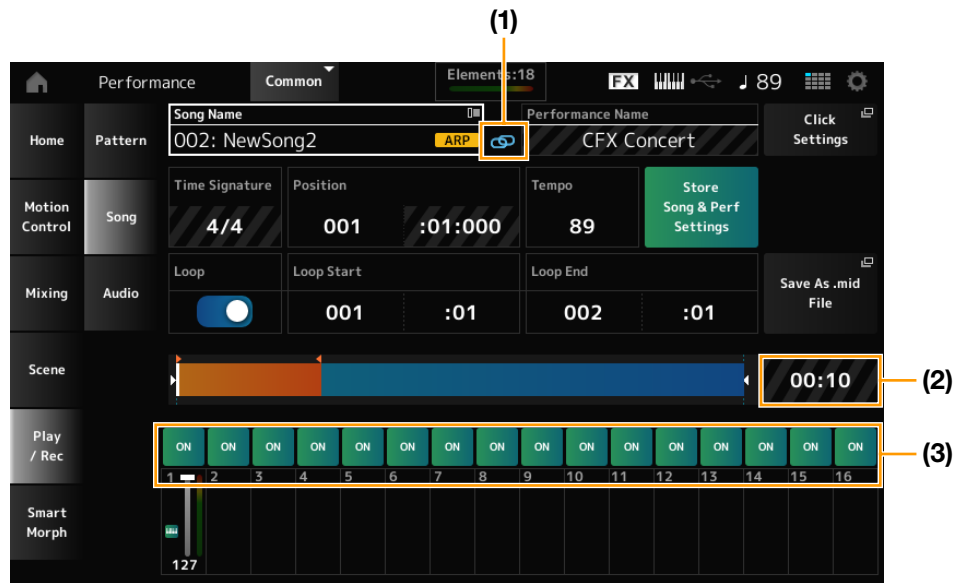

(1) Link Icon

(2) Song Length

(3) Track Play Switch

Song Name

Shows the name of the selected Song.

Tap to display the context menu for Load, Rename, New Song, and User Arp.

You can select a Song by using the [INC/YES] and [DEC/NO] buttons when the cursor is on the Song Name.

Performance Name

Shows the name of the selected Performance.

NOTE

The blue flag will be shown at the top right of the Performance Name when you change a parameter in the Performance.

Link Icon

The Link Icon is shown if the Performance used for recording the Song and the selected Performance are the same. If not, a broken Link Icon will be shown.

Click Settings

This calls up the Tempo Settings screen.

Time Signature

Shows the meter for the Pattern.

Position

Sets the position for starting playback and recording, as well as the current playback position.
The number shown on the left is the measure, and the numbers shown on the right are the beats and ticks.

Tempo

Sets the tempo for Song playback.

Settings: 5–300

Loop

Sets Loop playback on or off.

When set to On, the playback of a section between the Loop Start and Loop End points will be repeated.

Settings: Off, On

Loop Start**Loop End**

Sets the section for Loop playback. The number shown on the left is the measure, and the number shown on the right is the beat. This parameter is not available when Loop is set to Off.

Store Song & Perf Settings (Store Song and Performance Settings)

Saves the link between the edited Songs and the Performance used.

NOTE

If you have edited the Performance parameters, you will also need to store the Performance.

Save As .mid File

Pressing this button calls up the Save screen, allowing you to save the Song as a file.

Not available in the following situations.

- For a new recording (when there is no Song)
- During playback
- When recording standby is enabled
- During recording

Song Length

Shows the length of the entire sequence.

Track Play Switch

Turns playback of each track on or off.

Settings: Off, On

■ Recording and recording standby

Operation

[SONG/PATTERN] button → Song → [●] (Record) button

[PERFORMANCE (HOME)] → Play/Rec → Song → [●] (Record) button

New recording



When something has already been recorded



Time Signature

Shows the meter for the Song.

Settings: 1/16–16/16, 1/8–16/8, 1/4–8/4

Rec Quantize

Quantize is a function that corrects the recorded notes to be on the exact fraction of the beat (in note values).

Settings: Off, 60 (thirty-second note), 80 (sixteenth note triplet), 120 (sixteenth note), 160 (eighth note triplet), 240 (eighth note), 320 (quarter note triplet), 480 (quarter note)

Record Type

Selects a record type for the tracks already recorded.

This parameter is not available for a new recording.

Settings: Replace, Overdub, Punch

Replace: Overwrite and record in real-time. The existing data will be lost

Overdub: Overdub and record in real-time. The existing data will not be lost

Punch: Re-record a section and record in real-time. This overwrites the existing data of a specified section

Punch In

Sets the Punch in point (specific measure and beat at which to start re-recording).

This parameter is available only when Record Type is set to Punch.

Punch Out

Sets the Punch out point (specific measure and beat at which to end re-recording).

This parameter is available only when Record Type is set to Punch.

Arp Rec

When set to On, the results of Arpeggio playback are recorded. When set to Off, only the keyboard performance is recorded.

This parameter can be set for recording a new Song. The setting cannot be changed after the recording.

To add something to the Song recorded with Arp Rec set to Off, only Replace can be used for Record Type.

Settings: Off, On

NOTE

With the Song with Arp Rec set to Off, you can select a different Arpeggio for playback by changing the Arpeggio selection in the Performance.

Undo Media Record

Cancels the previous action and returns to the previous state.

This button becomes available when one or more Jobs have been used after a sequence has been recorded.

Redo Media Record

Restores the recording that has been canceled by Undo Media Record. Enabled when Undo Media Record was used.

Put Track to Arpeggio

Converts the selected Song to a User Arpeggio.

Up to 16 different notes can be converted. (All notes with the same Note Number are counted as one.)

Make sure to use only up to 16 notes for a Song if you wish to convert it to a User Arpeggio, especially when you use multiple tracks.

Operation

[SONG/PATTERN] button → Tap on Play/Rec → Song → Song Name to open the context menu → User Arp

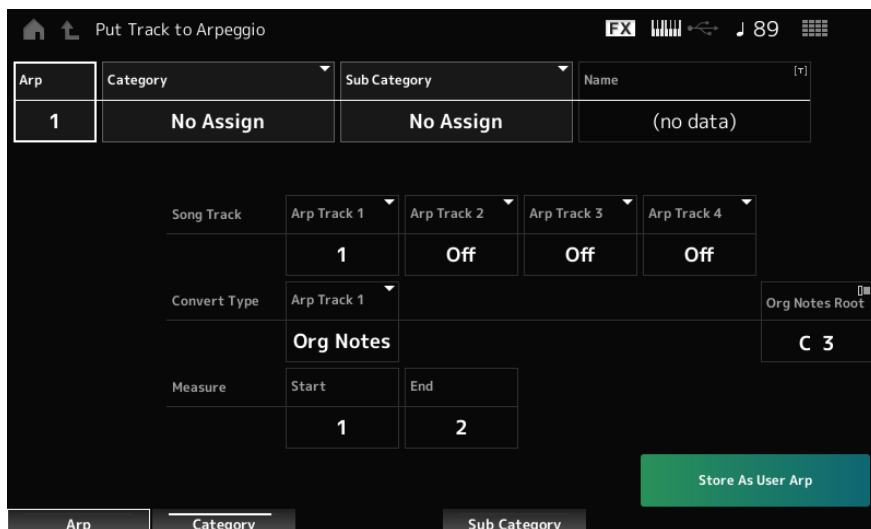

Arp (Arpeggio Number)

Sets the Arpeggio Number of the User Arpeggio for conversion.

Initially, the next unused number will be set.

Keep in mind that if you change this to a number already being used, the Arpeggio will be overwritten, meaning that you will lose the existing User Arpeggio for that number.

Settings: 1–256

Category (Arpeggio Category)

Sub Category (Arpeggio Sub Category)

Sets the Main and Sub categories of the converted Arpeggio.

Settings: Refer to the Data List

Name (Arpeggio Name)

Sets the Arpeggio Name. You can use up to 20 alphanumeric characters.

Song Track

Sets the track number of the Song to convert from for each Arpeggio track.

Settings: Off, 1–16

Convert Type

Selects how to convert the MIDI sequence recorded in the Song to the Arpeggio from three different settings.

You can use a different Convert Type for each Arpeggio track.

Settings: Normal, Fixed, Org Notes

Normal: The Arpeggio is played back at the same octave as the recorded MIDI Sequence

Fixed: The recorded MIDI sequence is played back the same way no matter how you play the keyboard.

Org Notes: Basically the same as Fixed, but the playback of the MIDI sequence changes according to the chords you play on the keyboard

Org Notes Root (Original Notes Root)

Sets the root note when the Convert Type of any track is set to Org Notes.

This parameter is not available when no track is set to Org Notes.

Settings: C–2–G8

Start Measure

Sets the starting measure for the conversion.

Settings: 1–998

End Measure

Sets the ending measure for the conversion.

Settings: 2–999

Store As User Arp

Converts the Song to a User Arpeggio with the settings specified on this screen.

This button is disabled when all tracks are set to Off.

Audio

On the Audio screen, you can record your keyboard performance as an audio file .wav (44.1-kHz, 24-bit stereo) to the USB flash drive. The maximum recording time is 74 minutes, or up to the capacity of the recording device.

■ Playback and playback standby

Operation

[SONG/PATTERN] button → Audio

[PERFORMANCE (HOME)] → Play/Rec → Audio

[▶] (Play) button → Audio

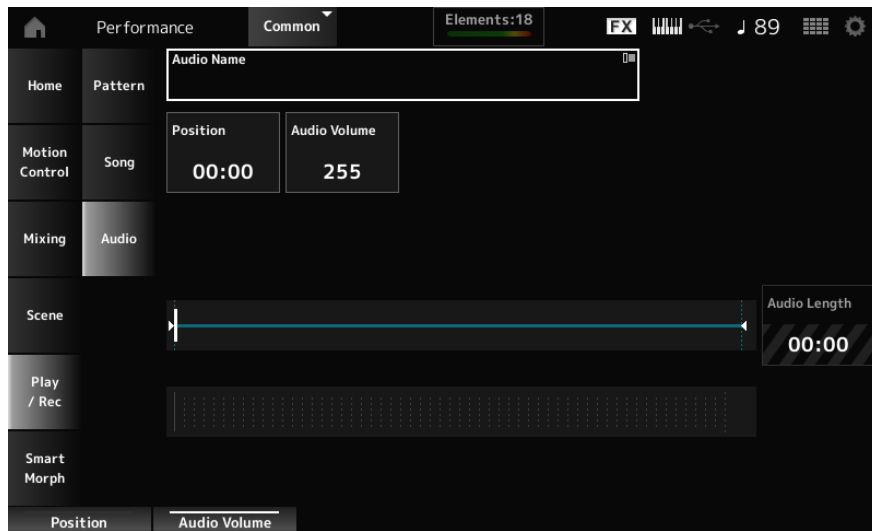

Audio Name

Shows the name of the selected Audio file.
Tap to display the context menu for Load.

Position

Sets the position for starting playback, as well as the current playback position.

Audio Volume

Sets the position for starting playback. This parameter is not available during recording.
Settings: 0–255

Audio Length

Shows the total length of the audio file.

Level meter

Shows the audio input and output level.

■ Recording and recording standby

Operation

[PERFORMANCE (HOME)] → Play/Rec → Audio → [●] (Record) button

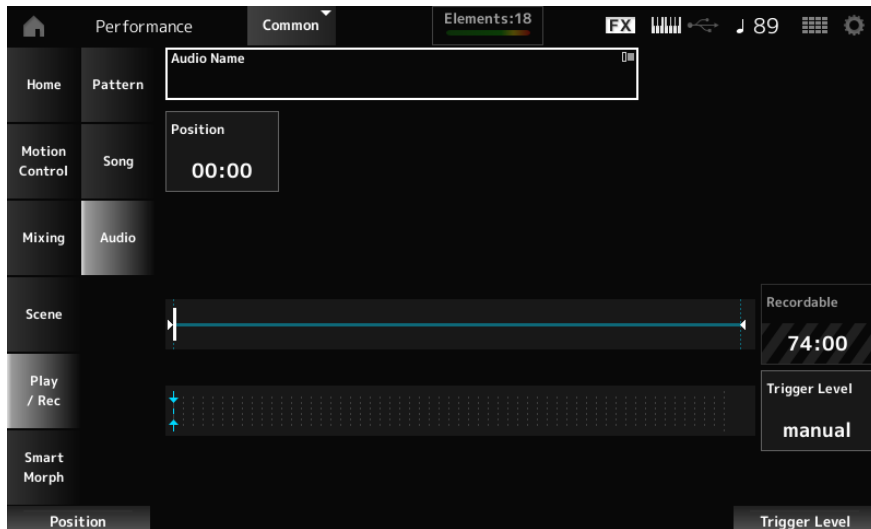

Recordable (Audio Recordable Time)

Shows the recordable time for audio. This parameter is shown only while recording standby is enabled.

Trigger Level

Selects how to start recording. This parameter is shown only while recording standby is enabled.

Settings: manual, 1–127

manual: Press the [▶] (Play) button to start recording

1–127: After pressing the [▶] (Play) button, recording will start when a signal exceeding the set value is input. The level set here will be indicated by blue triangles in the level meter

NOTE

For best results, set Trigger Level as low as possible to capture the entire signal, but not so low as to record unwanted noise.

Smart Morph

Play

Tap on the Smart Morph map, and create changes in the FM-X sound or AN-X sound on Part 1.

Operation

[PERFORMANCE (HOME)] → Smart Morph → Play

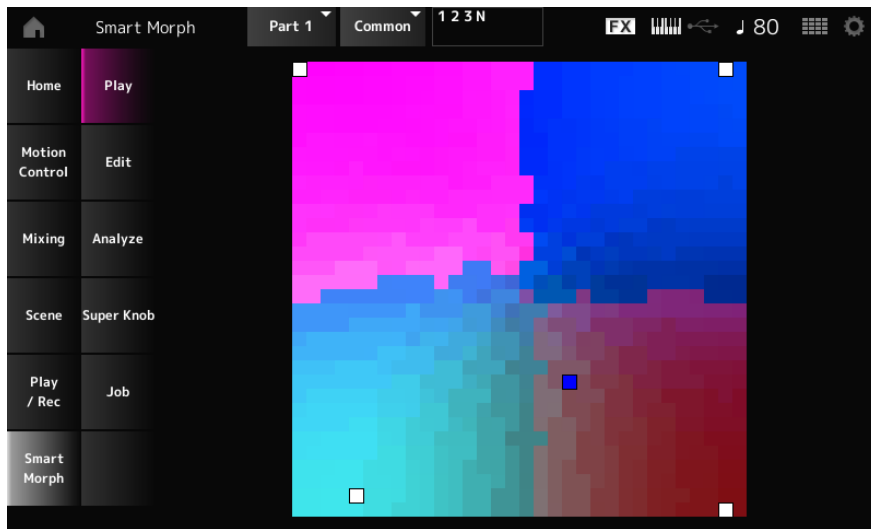

Edit

Operation

[PERFORMANCE (HOME)] → Smart Morph → Edit

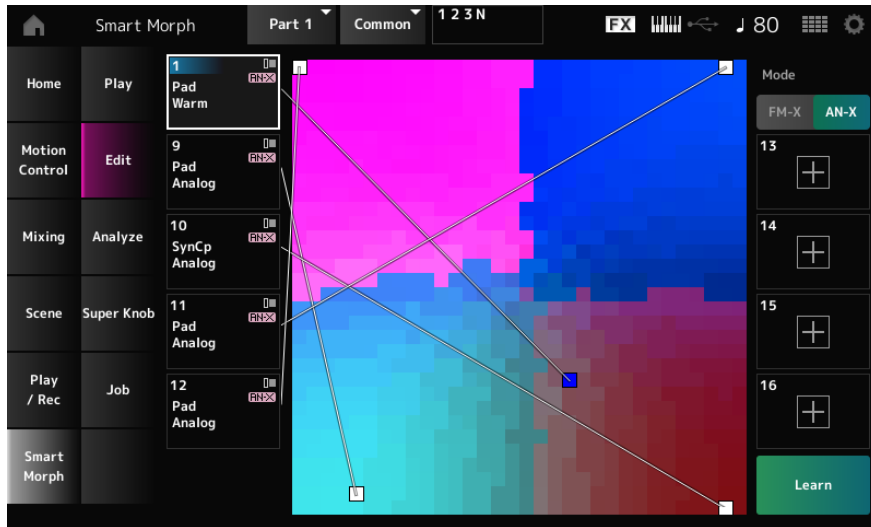

Unused Part

Tap to open the Part Category Search screen for selecting an FM-X sound or AN-X sound.

Part being used

Tap to display the context menu for Category Search, Edit, Property, etc.

Display

Selects the Part Main Category view or Part Name view for each Part.

Mode

Switches between FM-X and AN-X.

Settings: FM-X, AN-X

Learn

Tap the button to start machine learning (map creation).

This button will not be shown when there is no FM-X sound or AN-X sound on Parts 9 to 16.

Undo

Redo

After the Learn operation, the Undo button will be shown on the upper right.

Use the Undo button to restore the original map before using machine learning.

After the Undo operation, the Redo button will appear, and you can use it to restore the map before the Undo operation.

Analyze

Operation

[PERFORMANCE (HOME)] → Smart Morph → Analyze

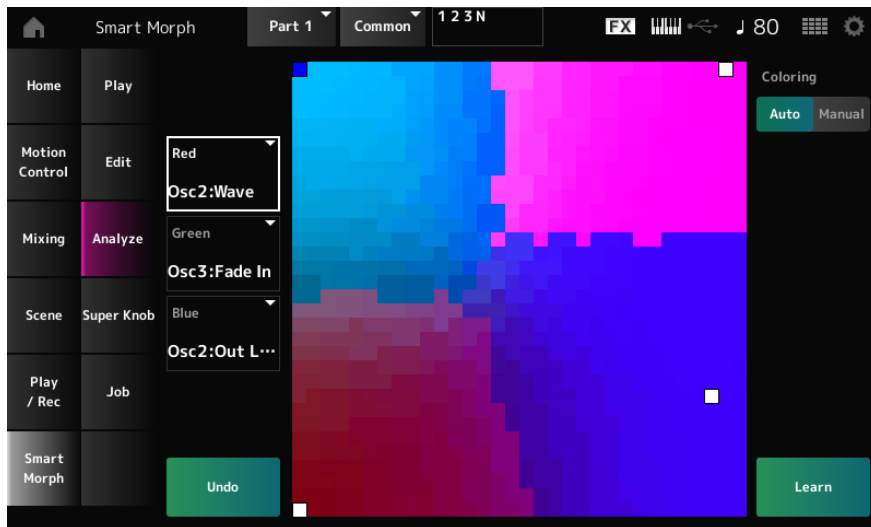

Red

Each dot on the map represents the parameter value indicating a degree or level as a shade of red.

Green

Each dot on the map represents the parameter value indicating a degree or level as a shade of green.

Blue

Each dot on the map represents the parameter value indicating a degree or level as a shade of blue.

NOTE

For the list of available Red, Green, and Blue parameters, see "Parameters that can be set for Red, Green, and Blue."

Coloring

When set to Auto, the Red, Green, and Blue are automatically reset for the Learn process.

When set to Manual, the Red, Green, and Blue are not automatically reset for the Learn process.

Settings: Auto, Manual

Learn

Tap the button to start machine learning (map creation).

Undo

Redo

After the Learn operation, the Undo button will be shown on the upper right.

Use the Undo button to restore the original map before using machine learning.

After the Undo operation, the Redo button will appear, and you can use it to restore the map before the Undo operation.

■ Parameters that can be set for Red, Green, and Blue

• FM Common

Display Name	Parameter Name
Random Pan Depth	Random Pan Depth
Alternate Pan	Alternate Pan Depth
Scaling Pan Depth	Scaling Pan Depth
KeyOnDly Time	Key On Delay Time Length
KeyOnDly Sync	Key On Delay Tempo Sync Switch
KeyOnDly Note	Key On Delay Note Length
Pitch/Vel	Pitch Velocity Sensitivity
Random Pitch Depth	Random Pitch Depth
Pitch/Key	Pitch Key Follow Sensitivity
Pitch/Key Center	Pitch Key Follow Sensitivity Center Note
PEG Initial Lvl	PEG Initial Level
PEG Attack Lvl	PEG Attack Level
PEG Decay 1 Lvl	PEG Decay 1 Level
PEG Decay 2 Lvl	PEG Decay 2 Level
PEG Release Lvl	PEG Release Level
PEG Attack Tm	PEG Attack Time
PEG Decay 1 Tm	PEG Decay 1 Time
PEG Decay 2 Tm	PEG Decay 2 Time
PEG Release Tm	PEG Release Time
PEG Depth/Vel	PEG Depth Velocity Sensitivity
PEG Depth	PEG Depth
PEG Time/Key	PEG Time Key Follow Sensitivity
2nd LFO Wave	2nd LFO Wave
LFO Speed	2nd LFO Speed
LFO Phase	2nd LFO Phase
LFO Delay	2nd LFO Delay Time
LFO Key On Reset	2nd LFO Key On Reset
LFO Pitch Mod	2nd LFO Pitch Modulation Depth
LFO Amp Mod	2nd LFO Amp Modulation Depth
LFO Filter Mod	2nd LFO Filter Modulation Depth
Algorithm Number	Algorithm Number
Feedback Level	Feedback Level
LFO Speed Range	LFO Speed Range
LFO Ex Speed	LFO Extended Speed
Filter Type	Filter Type
Cutoff	Filter Cutoff Frequency
Cutoff/Vel	Filter Cutoff Velocity Sensitivity
Resonance / Width	Filter Resonance/Width
Res/Vel	Resonance Velocity Sensitivity
HPF Cutoff	HPF Cutoff Frequency
Distance	Distance
Filter Gain	Filter Gain
FEG Hold Tm	FEG Hold Time

Display Name	Parameter Name
FEG Attack Tm	FEG Attack Time
FEG Decay 1 Tm	FEG Decay 1 Time
FEG Decay 2 Tm	FEG Decay 2 Time
FEG Release Tm	FEG Release Time
FEG Hold Lvl	FEG Hold Level
FEG Attack Lvl	FEG Attack Level
FEG Decay 1 Lvl	FEG Decay 1 Level
FEG Decay 2 Lvl	FEG Decay 2 Level
FEG Release Lvl	FEG Release Level
FEG Depth	FEG Depth
FEG Segment	FEG Time Velocity Sensitivity Segment
FEG Time/Vel	FEG Time Velocity Sensitivity
FEG Depth/Vel	FEG Depth Velocity Sensitivity
FEG Curve	FEG Depth Velocity Sensitivity Curve
FEG Time/Key	FEG Time Key Follow Sensitivity
FEG Center	FEG Time Key Follow Sensitivity Center Note
Filt Cutoff/Key	Filter Cutoff Key Follow Sensitivity
Filt Break Point 1	Filter Cutoff Scaling Break Point 1
Filt Break Point 2	Filter Cutoff Scaling Break Point 2
Filt Break Point 3	Filter Cutoff Scaling Break Point 3
Filt Break Point 4	Filter Cutoff Scaling Break Point 4
Filt Cutoff Offset 1	Filter Cutoff Scaling Offset 1
Filt Cutoff Offset 2	Filter Cutoff Scaling Offset 2
Filt Cutoff Offset 3	Filter Cutoff Scaling Offset 3
Filt Cutoff Offset 4	Filter Cutoff Scaling Offset 4
HPF Cutoff/Key	HPF Cutoff Key Follow Sensitivity

• Operator

Display Name	Parameter Name
Key On Reset	Oscillator Key On Reset
Freq Mode	Oscillator Frequency Mode
Coarse	Tune Coarse
Fine	Tune Fine
Detune	Detune
Pitch/Key	Pitch Key Follow Sensitivity
Pitch/Vel	Pitch Velocity Sensitivity
Spectral	Spectral Form
Skirt	Spectral Skirt
Resonance	Spectral Resonance
PEG Initial Lvl	PEG Initial Level
PEG Attack Lvl	PEG Attack Level
PEG Attack Tm	PEG Attack Time
PEG Decay Tm	PEG Decay Time
AEG Attack Lvl	AEG Attack Level
AEG Decay 1 Lvl	AEG Decay 1 Level

Display Name	Parameter Name
AEG Decay 2 Lvl	AEG Decay 2 Level
AEG Release Lvl	AEG Release (Hold) Level
AEG Attack Tm	AEG Attack Time
AEG Decay 1 Tm	AEG Decay 1 Time
AEG Decay 2 Tm	AEG Decay 2 Time
AEG Release Tm	AEG Release Time
AEG Hold Tm	AEG Hold Time
AEG Time/Key	AEG Time Key Follow Sensitivity
Level	Operator Level
Lvl Break Point	Level Scaling Break Point
Lvl/Key Lo	Level Scaling Low Depth
Lvl/Key Hi	Level Scaling High Depth
Curve Lo	Level Scaling Low Curve
Curve Hi	Level Scaling High Curve
Level/Vel	Level Velocity Sensitivity
LFO PM Depth	2nd LFO Pitch Modulation Depth Offset
LFO AM Depth	2nd LFO Amplitude Modulation Depth Offset
Pitch/Ctrl	Pitch Controller Sensitivity
Level/Ctrl	Level Controller Sensitivity

• AN-X Common

Display Name	Parameter Name
Random Pan	Random Pan Depth
Alternate Pan	Alternate Pan Depth
Scaling Pan	Scaling Pan Depth
Delay Length	Key On Delay Time Length
KeyOnDly Sync	Key On Delay Tempo Sync Switch
Delay Length	Key On Delay Note Length
Unison	Unison
Unison Detune	Unison Detune
Unison Spread	Unison Spread
OSC Reset	OSC Reset
Voltage Drift	Voltage Drift
Ageing	Ageing
Attack	Pitch EG Attack Time
Decay	Pitch EG Decay Time
Sustain	Pitch EG Sustain Level
Release	Pitch EG Release Time
Time/Vel	Pitch EG Time Velocity Sensitivity
Wave	Pitch LFO Wave
Speed	Pitch LFO Speed
Key On Reset	Pitch LFO Key On Reset
Phase	Pitch LFO Phase
Delay	Pitch LFO Delay Time
Fade In	Pitch LFO Fade In Time

Display Name	Parameter Name
Noise Tone	Noise Generator Tone
Connect	Noise Generator Out Select
Out Level	Noise Generator Out Level
Out Level/Vel	Noise Generator Out Level Velocity Sensitivity
Attack	Filter Cutoff EG Attack Time
Decay	Filter Cutoff EG Decay Time
Sustain	Filter Cutoff EG Sustain Level
Release	Filter Cutoff EG Release Time
Time/Vel	Filter Cutoff EG Time Velocity Sensitivity
Wave	Filter Cutoff LFO Wave
Speed	Filter Cutoff LFO Speed
Key On Reset	Filter Cutoff LFO Key On Reset
Phase	Filter Cutoff LFO Phase
Delay	Filter Cutoff LFO Delay Time
Fade In	Filter Cutoff LFO Fade In Time
Level	Amplitude Level
Level/Vel	Amplitude Level Velocity Sensitivity
LFO Depth	Amplitude Level LFO Depth
Level/Key	Amplitude Level Key Follow
Drive	Amplitude Saturator Drive
Attack	Amplitude EG Attack Time
Decay	Amplitude EG Decay Time
Sustain	Amplitude EG Sustain Level
Release	Amplitude EG Release Time
Time/Vel	Amplitude EG Time Velocity Sensitivity
Wave	Amplitude LFO Wave
Speed	Amplitude LFO Speed
Key On Reset	Amplitude LFO Key On Reset
Phase	Amplitude LFO Phase
Delay	Amplitude LFO Delay Time
Fade In	Amplitude LFO Fade In Time

• **Oscillator**

Display Name	Parameter Name
Wave	Oscillator Wave
Octave	Oscillator Octave
Pitch	Oscillator Pitch
Pitch EG Depth	Oscillator Pitch EG Depth
Pitch EG Depth/Vel	Oscillator Pitch EG Depth Velocity Sensitivity
Pitch LFO Depth	Oscillator Pitch LFO Depth
Sync Pitch	Oscillator Self Sync Pitch
Sync Pitch/Vel	Oscillator Self Sync Pitch Velocity Sensitivity
Sync	Oscillator Self Sync EG Depth
Sync	Oscillator Self Sync LFO Depth
Pulse Width	Oscillator Pulse Width
PulseWidth/Vel	Oscillator Pulse Width Velocity Sensitivity
Pulse Width	Oscillator Pulse Width EG Depth
Pulse Width	Oscillator Pulse Width LFO Depth
Shaper	Oscillator Wave Shaper
Shaper/Vel	Oscillator Wave Shaper Velocity Sensitivity
Shaper	Oscillator Wave Shaper EG Depth
Shaper	Oscillator Wave Shaper LFO Depth
FM Level	Oscillator FM Level
FM Level/Vel	Oscillator FM Level Velocity Sensitivity
Ring Level	Oscillator Ring Level
Ring Level/Vel	Oscillator Ring Level Velocity Sensitivity
Connect	Oscillator Out Select
Invert	Oscillator Out Invert Enable
Out Level	Oscillator Out Level
Out Level/Vel	Oscillator Out Level Velocity Sensitivity
Attack	Oscillator EG Attack Time
Decay	Oscillator EG Decay Time
Sustain	Oscillator EG Sustain Level
Release	Oscillator EG Release Time
Wave	Oscillator LFO Wave
Speed	Oscillator LFO Speed
Key On Reset	Oscillator LFO Key On Reset
Phase	Oscillator LFO Phase
Delay	Oscillator LFO Delay Time
Fade In	Oscillator LFO Fade In Time

• **Filter**

Display Name	Parameter Name
Type	Filter Type
Cutoff	Filter Cutoff
Cutoff/Vel	Filter Cutoff Velocity Sensitivity
Filter EG Depth	Filter Cutoff EG Depth
Filter EG Depth/Vel	Filter Cutoff EG Depth Velocity Sensitivity
Filter LFO Depth	Filter Cutoff LFO Depth
Cutoff/Key	Filter Cutoff Key Follow
Resonance	Filter Resonance
Resonance/Vel	Filter Resonance Velocity Sensitivity
Saturator Drive	Filter Saturator Drive
Saturator Drive/...	Filter Saturator Drive Velocity Sensitivity
Out Level	Filter Out Level

• **Modifier**

Display Name	Parameter Name
Wave Folder	Modifier Wave Folder
Folder/Vel	Modifier Wave Folder Velocity Sensitivity
EG Depth	Modifier Wave Folder EG Depth
LFO Depth	Modifier Wave Folder LFO Depth
Texture	Modifier Wave Folder Texture
Type	Modifier Wave Folder Type
Attack	Modifier EG Attack Time
Decay	Modifier EG Decay Time
Sustain	Modifier EG Sustain Level
Release	Modifier EG Release Time
Time/Vel	Modifier EG Time Velocity Sensitivity
Wave	Modifier LFO Wave
Speed	Modifier LFO Speed
Key On Reset	Modifier LFO Key On Reset
Phase	Modifier LFO Phase
Delay	Modifier LFO Delay Time
Fade In	Modifier LFO Fade In Time

Super Knob

Operation

[PERFORMANCE (HOME)] → Smart Morph → Super Knob

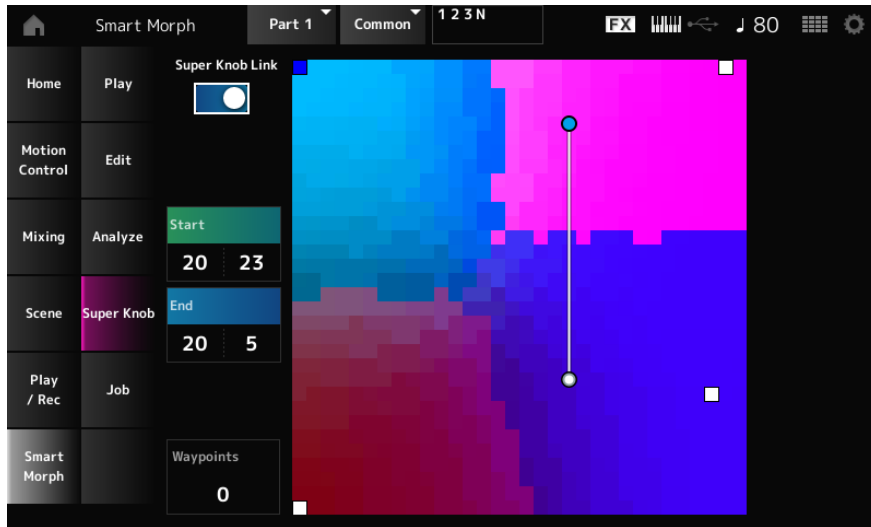

Super Knob Link

When set to On, you can use the Super Knob for following the path on the map from start to end, instead of running your finger across the touchscreen.

Settings: Off, On

Start

Sets the position of the smallest Super Knob value on the map.

When the cursor is on Start, tap on the map to set the value for the starting point.

End

Sets the position of the largest Super Knob value on the map.

When the cursor is on End, tap on the map to set the value of the ending point.

Waypoints

Sets the number of interspersed points (waypoints) between the start and end.

Settings: 0–6

Waypoint 1–Waypoint 6

Sets the position on the map.

Job

Operation

[PERFORMANCE (HOME)] → Smart Morph → Job



Load Smart Morph

Opens the Load screen.

On the Load screen, you can select another Performance and import the Smart Morph settings from that Performance to the current Performance.

Delete Smart Morph

Deletes the Smart Morph settings from the selected Performance.

Delete Part 9–16

Deletes all Parts 9 to 16 at once to make these Parts unused.

Parts 9 to 16 are used for creating a Smart Morph map.

When you are finished adjusting the parameters and you no longer need to use the map, you can delete Parts 9 to 16.

Common Edit Screens

On the Common Edit screen, you can edit the parameters for the entire Performance as well as the parameters for the Audio Part.

General/Pitch

Perf Settings

On the Perf Settings screen, you can set general parameters for the Performance.

Operation

[PERFORMANCE (HOME)] → Common selection → [EDIT/⟳] → General/Pitch → Perf Settings

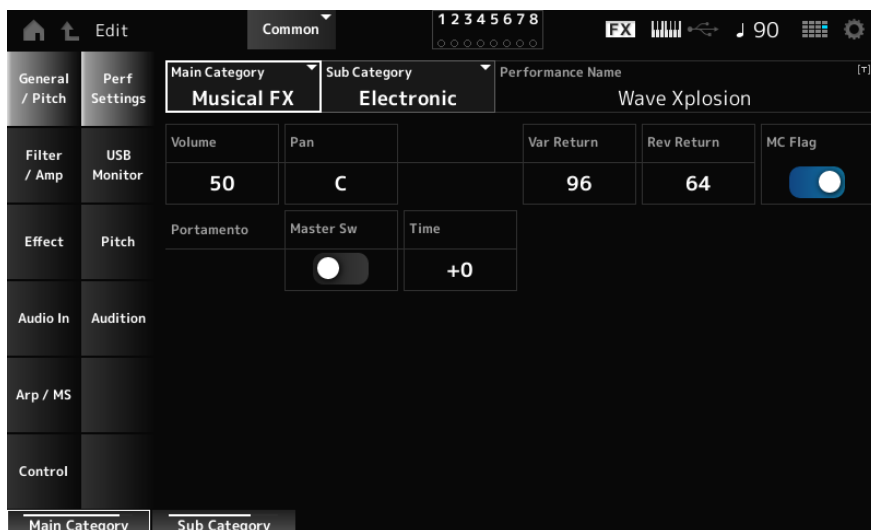

Main Category

Sub Category

Sets the Main category and Sub category of the selected Performance.

Settings: Refer to the Data List

Performance Name

Names the currently selected Performance. You can use up to 20 alphanumeric characters.

Volume (Performance Volume)

Sets the volume of the selected Performance.

Settings: 0–127

Pan (Performance Pan)

Adjusts the Pan position (stereo position) of the currently selected Performance.

Settings: L63–C (center)–R63

Var Return (Variation Return)

Sets the output level (Return Level) of the signals processed by the Variation Effect.

Settings: 0–127

Rev Return (Reverb Return)

Sets the output level (Return Level) of the signals processed by the Reverb Effect.

Settings: 0–127

MC Flag (Motion Control Flag)

Sets an MC (Motion Control) flag to the currently selected Performance.

When set to On, the MC flag appears on the Performance screen (HOME), and filtering will be performed by the MC attribute on the Performance Category Search screen.

Settings: Off, On

Portamento Master Sw (Portamento Master Switch)

Sets Portamento on or off for Parts having the Portamento Part Sw set to On.

This switch is linked to the [PORTAMENTO] button on the top panel.

Settings: Off, On

Portamento Time

Sets the time length (or speed) for the pitch transition of Portamento for the Part.

This is specified as an offset value to the Part Portamento time.

Settings: –64–+0–+63

USB Monitor

Adjusts the volume of the audio signal input from the USB [TO HOST] terminal on the USB Monitor screen. When you tap on the USB Volume in the Audio Signal Flow, the cursor moves on the Audio I/O screen to the USB Volume.

NOTE

USB Main Monitor Volume is saved (stored) in the Performance.

Operation

[PERFORMANCE (HOME)] → Common selection → [EDIT/↶↷] → General/Pitch → USB Monitor

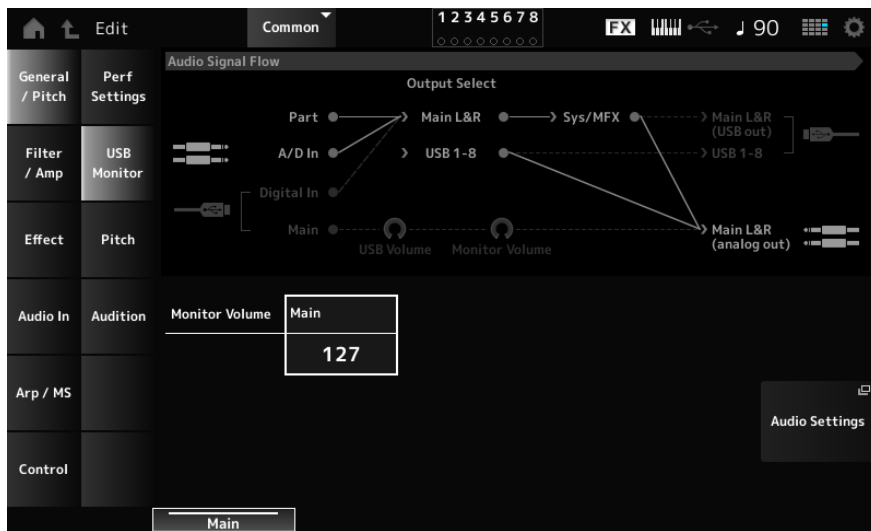

Monitor Volume Main

Adjusts the volume of the audio signals input from the USB [TO HOST] terminal and output to the OUTPUT jacks. Settings: 0–127

Audio Settings

Tap to open the Utility Audio I/O screen.

The same screen can be opened from [UTILITY] → Settings → Audio I/O.

Pitch

On the Pitch screen, you can make pitch settings.

Operation

[PERFORMANCE (HOME)] → Common selection → [EDIT/↶] → General/Pitch → Pitch
[SHIFT] + [PORTAMENTO]

■ Note Shift / Detune

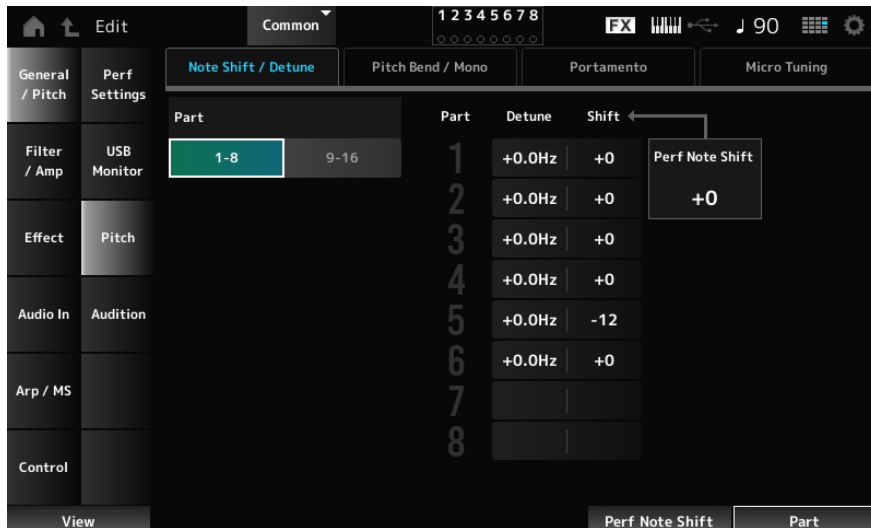

Part

Switches the view between Part 1-8 and Part 9-16.

Detune

Adjusts the pitch of the Part in 0.1 Hz increments.

By slightly shifting the pitch, you can detune the sound.

Settings: -12.8Hz~+0.0Hz~+12.7Hz

Shift (Note Shift)

Adjusts the pitch of the Part in semitones.

Settings: -24~+0~+24

Perf Note Shift (Performance Note Shift)

Adjusts the pitch of all Parts in semitones.

Settings: -24~+0~+24

■ Pitch Bend / Mono

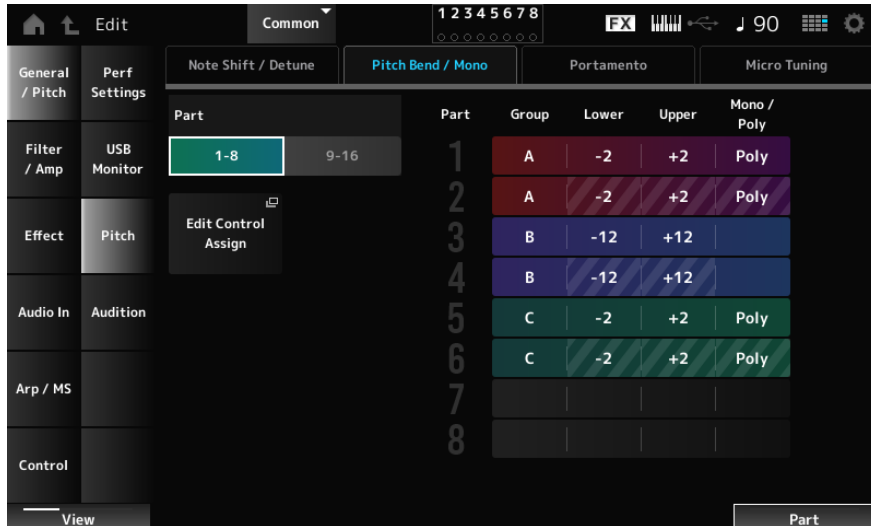

Mono / Poly will not be shown for the Drum Part.

Edit Control Assign

The Common Edit Control Assign screen will open.

Group (Pitch Control Group)

Parts assigned to the same group are given the same pitch.

This is convenient when you wish to apply Portamento to a layered sound or have the same micro-tuning settings for multiple Parts at once.

Lower (Pitch Bend Lower)

Upper (Pitch Bend Upper)

Sets the range of the changes created with the pitch bend wheel in semitones.

Settings: -48--+0--+24

Mono / Poly

Sets the tone generation mode for the keyboard.

Mono is for playing single notes, and Poly is for playing multiple simultaneous notes.

Settings: Mono, Poly

■ Portamento

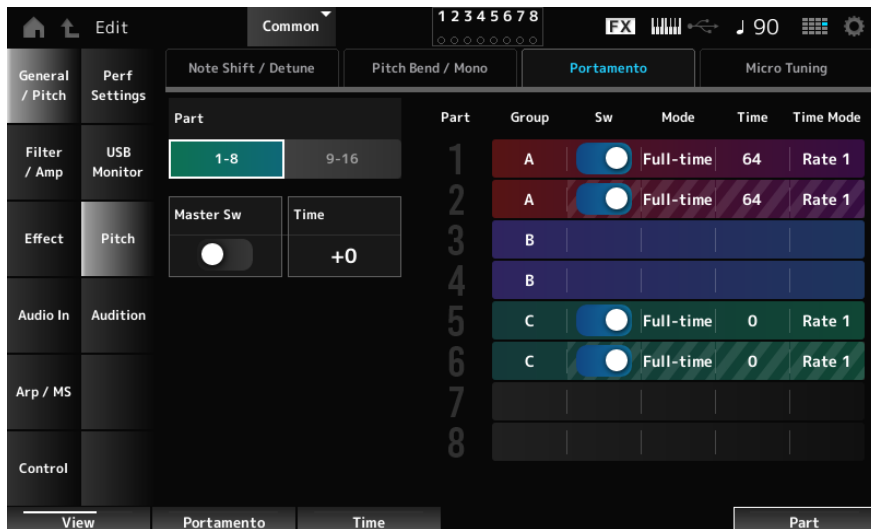

Sw, Mode, Time, and Time Mode will not be shown for the Drum Part.

Master Sw (Portamento Master Switch)

Sets Portamento on or off for Parts having the Sw (Portamento Part Switch) set to On.

This switch is linked to the [PORTAMENTO] button on the top panel.

Settings: Off, On

Time (Portamento Time)

Sets the time length (or speed) for the pitch transition of Portamento for the Part.

This is specified as an offset value to the Part Portamento time.

Settings: -64--+0--+63

Sw (Portamento Part Switch)

Sets Portamento on or off for the Part.

Settings: Off, On

Portamento Mode

Sets the way Portamento is applied according to your keyboard performance.

Settings: Fingered, Full-time

Fingered: Portamento is applied only when you play legato (playing the next note before releasing the previous one)

Full-time: Portamento is applied at all times

Time (Portamento Part Time)

Sets the time length (or speed) for the pitch transition of Portamento for the Part.

Settings: 0-127

Time Mode (Portamento Time Mode)

Sets how the pitch changes over time.

Settings: Rate 1, Time 1, Rate 2, Time 2

Rate 1: Pitch changes at a specific rate.

Time 1: Pitch changes at a specific time.

Rate 2: Pitch changes at a specific rate within an octave.

Time 2: Pitch changes at a specific time within an octave.

■ Micro Tuning

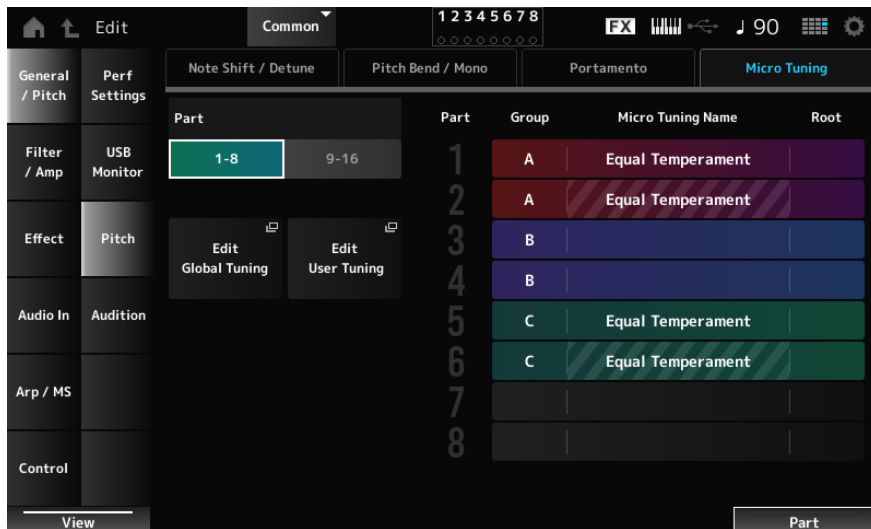

Micro Tuning Name and Root will not be shown for the Drum Part.

Edit Global Tuning

Opens Settings → Sound on the Utility screen.

Edit User Tuning

Opens the User Micro Tuning settings window.

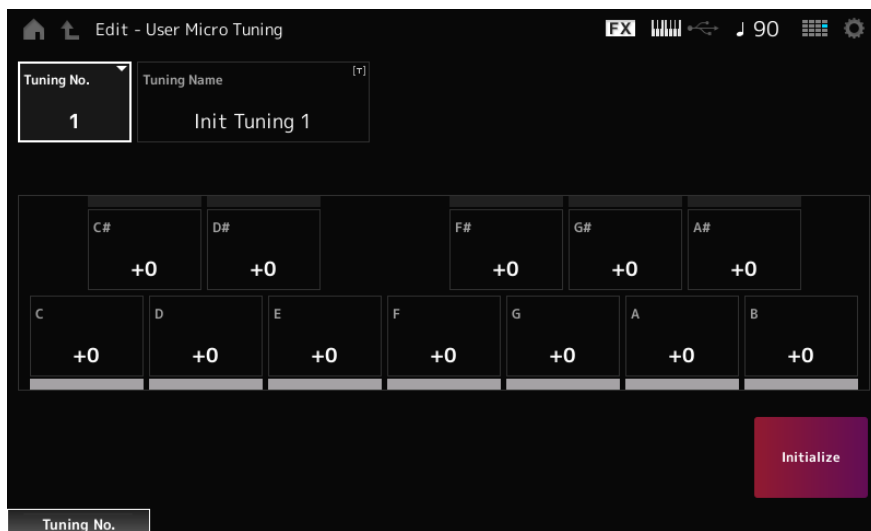

- Tuning No. (Micro Tuning Number)**
 Indicates the selected User Micro Tuning Number.
 Settings: 1–8
- Tuning Name (Micro Tuning Name)**
 You can save the User Micro Tuning you are editing under a new name. You can use up to 20 alphanumeric characters.
- C, C#, D, D#, E, F, F#, G, G#, A, A#, B**
 You can adjust the pitch of each note in cent to set the micro tuning.
 Settings: -99–+0–+99
- Initialize**
 Initializes the selected User Micro Tuning.

Micro Tuning Name

Sets the micro tuning (temperament) for the Part. See the table below for an explanation of each setting.

Settings: Equal Temperament, Pure Major, Pure Minor, Werckmeister, Kirnberger, Vallotti & Young, 1/4 shift, 1/4 tone, 1/8 tone, Indian, Arabic 1, Arabic 2, Arabic 3

Init Tuning 1–8 (When a user bank is selected)

Library 1–1 – 24–8 (When loading a Library file)

Equal Temperament	Each octave is divided into 12 intervals of equal size. This is the most commonly used tuning in music.
Pure Major Pure Minor	These tunings preserve the pure mathematical intervals of each scale, especially for triad chords (root, third, fifth). You can hear this best in actual vocal harmonies, such as choirs and a cappella singing.
Werckmeister Kirnberger Vallotti & Young	Each of the scales combines the mean-tone and Pythagorean scales. The main feature of these scales is that each key has its unique character. They were used in the time of Bach and Beethoven, and are used now when playing music from those eras on instruments like the harpsichord.
1/4 shift	The equal-tempered scale shifted up 50 cents. You can create tension in your music by mixing this setting with Equal Temperament.
1/4 tone	Twenty-four equally spaced notes per octave. One octave consists of 24 keys.
1/8 tone	Forty-eight equally spaced notes per octave. One octave consists of 48 keys.
Indian	Usually observed in Indian music. Play white keys only.
Arabic	Usually observed in Arabic music.

Root (Micro Tuning Root)

Sets the root note for the micro tuning.

This parameter is not shown when the selected type in Micro Tuning Name does not require a root note.

Settings: C–B

Audition

On the Audition screen, you can set the audition phrase.

Operation

[PERFORMANCE (HOME)] → Common selection → [EDIT/⟳] → General/Pitch → Audition



Audition Bank

Selects the bank for the audition phrases.

Audition Phrase Number

Selects the audition phrase.

The preset Performances already have suitable audition phrases assigned.

By playing back the audition phrase, you can listen to the selected Performance in an appropriate musical context.

Settings: Refer to the Data List

Note Shift (Audition Note Shift)

Adjusts the pitch of the notes in the audition phrase in semitones.

Settings: -24 semi to +0 semi to +24 semi

Velocity Shift (Audition Velocity Shift)

Adjusts the velocity of the notes in the audition phrase.

Settings: -64+0+63

Update User Auditions

Converts all Songs saved to internal memory into User Auditions.

If any User Auditions already exist, all previous User Auditions will be overwritten.

Filter EG

On the Filter EG screen, you can set the Filter Envelope Generator (FEG).

This lets you set the degree (or level) of changes to the cutoff frequency and how those changes evolve over time, starting from the moment you press a key on the keyboard to the moment the sound decays.

Operation

[PERFORMANCE (HOME)] → Common selection → [EDIT/↶] → Filter/Amp → Filter EG

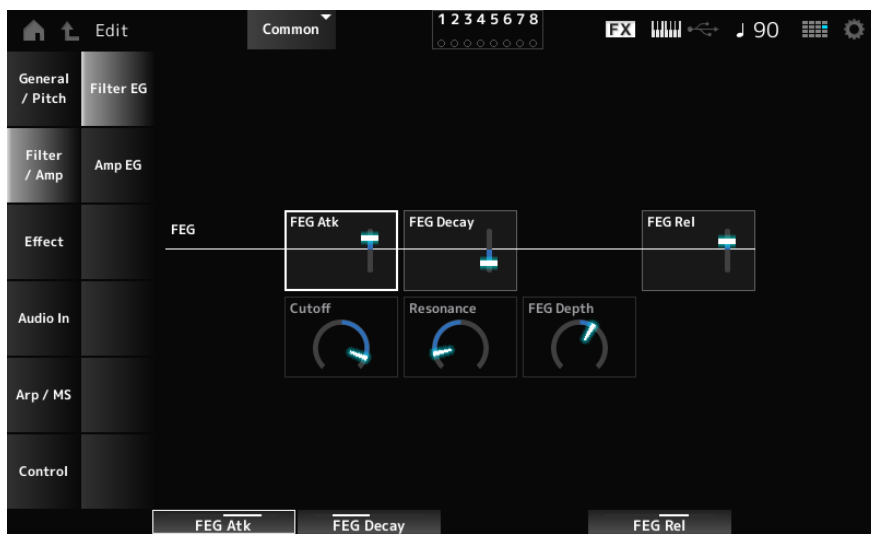

FEG Atk (FEG Attack Time)

Sets the length of time it takes for the sound to change from the moment you press a key to when the Cutoff Frequency reaches the value set at Attack Level.

This is specified as an offset value to the Part FEG.

Settings: -64+0+63

FEG Decay (FEG Decay Time)

Sets the length of time it takes for the Cutoff Frequency to change from the attack level. You can control the crispness or the decay speed of the sound.

This is specified as an offset value to the Part FEG.

Settings: -64+0+63

FEG Rel (FEG Release Time)

Sets the length of time it takes for the Cutoff Frequency to change from the moment you release your finger from the key until it reaches the Release Level. This allows you to make the decay of the sound after the key is released slower or faster.

This is specified as an offset value to the Part FEG.

Settings: -64+0+63

Cutoff (Cutoff Frequency)

Changes the sound by setting the cutoff frequency of the filter.

When the Low Pass Filter is selected, larger values here result in a brighter sound, and smaller values result in a darker sound.

This is specified as an offset value to the filter cutoff frequency for the Part.

Settings: -64+0+63

Resonance

Adds special characteristics to the sound by adjusting the signal level near the cutoff frequency.

This is specified as an offset value to the filter resonance for the Part.

Settings: -64-+0-+63

FEG Depth

Sets the depth range for the cutoff frequency change controlled by the FEG.

This is specified as an offset value to the Part's FEG Depth.

Settings: -64-+0-+63

Amp EG

On the Amp EG screen, you can set the AEG (Amplitude Envelope Generator). By setting the Amp EG, you can set how the volume changes from the moment you press a key on the keyboard to when the sound decays.

Operation

[PERFORMANCE (HOME)] → Common selection → [EDIT/↶] → Filter/Amp → Amp EG



The settings on the Amp EG screen are offset values to the AEG for all Parts.

Attack (AEG Attack Time)

Sets the length of time it takes for the volume to change from the moment you press a key on the keyboard to when it reaches the maximum.

Settings: -64-+0-+63

Decay (AEG Decay Time)

Sets the length of time it takes for the volume to change after it has reached the maximum.

Settings: -64-+0-+63

Sustain (AEG Sustain Level)

Sets the volume that is maintained while the key is held down.

Settings: -64-+0-+63

Release (AEG Release Time)

Sets the length of time it takes for the sound to decay after you have released the key.

Settings: -64-+0-+63

Routing

On this screen, you can set the System Effects applied to all Parts and view the signal flow of the Master Effects.

Operation

[PERFORMANCE (HOME)] → Common selection → [EDIT/↺] → Effect → Routing

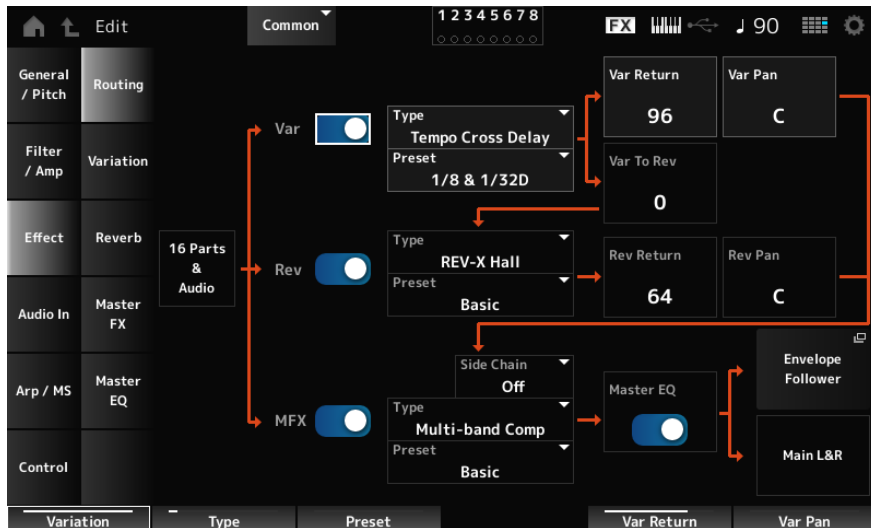

Var (Variation Switch)

Rev (Reverb Switch)

MFX (Master Effect Switch)

Sets the Variation Effect, Reverb, and Master Effect on or off.

Settings: Off, On

Var Type (Variation Type)

Rev Type (Reverb Type)

MFX Type (Master Effect Type)

Sets the type for the Variation Effect, Reverb, and Master Effect.

Settings: Refer to the Effect types

Var Preset (Variation Preset Number)

Rev Preset (Reverb Preset Number)

MFX Preset (Master Effect Preset Number)

Selects a Preset from the Variation Effect, Reverb, and Master Effect parameters.

Settings: Refer to the Data List

Side Chain (Variation Side Chain Part)

Side Chain (Master Effect Side Chain Part)

Modulator (Variation Modulator Part)

Modulator (Master Effect Modulator Part)

Sets the Side Chain Part (or the Modulator depending on the effect type) for the Variation Effect and Master Effect.

This parameter is not available when Master is set to the Modulator Part. In that case, the parameter value will be shown in parenthesis as in "(Master)."

Settings: Part 1–16, A/D, Master, Off

Var Return (Variation Return)

Rev Return (Reverb Return)

Sets the output level (Return Level) of the signals processed by the Variation Effect or Reverb Effect.

Settings: 0–127

Var to Rev (Variation To Reverb)

Sets the send level of the signals processed by the Variation Effect.

Settings: 0–127

Master EQ (Master EQ Switch)

Sets the Master EQ on or off.

Settings: Off, On

Var Pan (Variation Pan)

Rev Pan (Reverb Pan)

Sets the stereo location of the signals processed by the Variation Effect or the Reverb Effect.

Settings: L63–C (center)–R63

Envelope Follower

Opens the settings screen for the Envelope Follower.

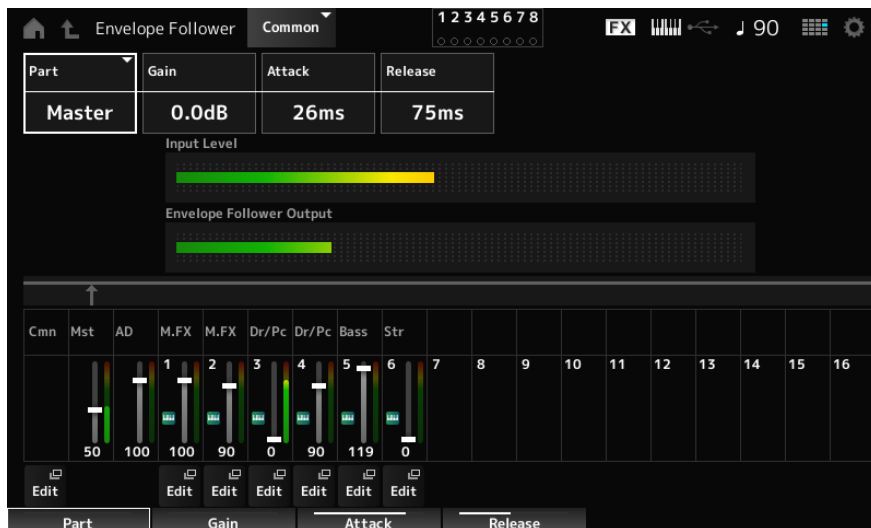

- **Part (Input Source)**

Shows the input source for the selected Envelope Follower.

Settings: Master, AD, Part 1–16

- **Gain (Envelope Follower Gain)**

Sets the input gain on the input source set for the Part.

Settings: –24.0dB–0.0dB–+24.0dB

- **Attack (Envelope Follower Attack)**

Sets the attack time for the envelope follower.

Settings: 1ms–40ms

- **Release (Envelope Follower Release)**

Sets the release time for the envelope follower.

Settings: 10ms–680ms

- **Input Level**

Shows the Input level for the signals input from the Input source of the Part you have selected.

- **Envelope Follower Output**

Shows the output level of the Envelope Follower.

- **Edit**

Opens the Control Assign screen for the selected Part.

Variation

Sets the Variation Effect.

Operation

[PERFORMANCE (HOME)] → Common selection → [EDIT/⟳] → Effect → Variation



Variation Switch

Sets the Variation Effect on or off.

Settings: Off, On

Category (Variation Category)

Type (Variation Type)

Sets the category and type of the Variation Effect.

Settings: Refer to the Effect types

Preset (Variation Preset Number)

Selects one of the Preset effect parameters for each Effect Type.

Settings: Refer to the Data List

Side Chain (Variation Side Chain Part)

Modulator (Variation Modulator Part)

Sets the Part for the Side Chain (or the Modulator depending on the effect type) for the Variation Effect.

This parameter is not available when Master is set to the Modulator Part. In that case, the parameter value will be shown in parenthesis as in "(Master)."

Settings: Part 1–16, A/D, Master, Off

Effect Parameter

The Effect Parameters differ depending on the effect type.

Settings: Refer to the Effect parameters

Reverb

Sets the Reverb Effect.

Operation

[PERFORMANCE (HOME)] → Common selection → [EDIT/↶] → Effect → Reverb

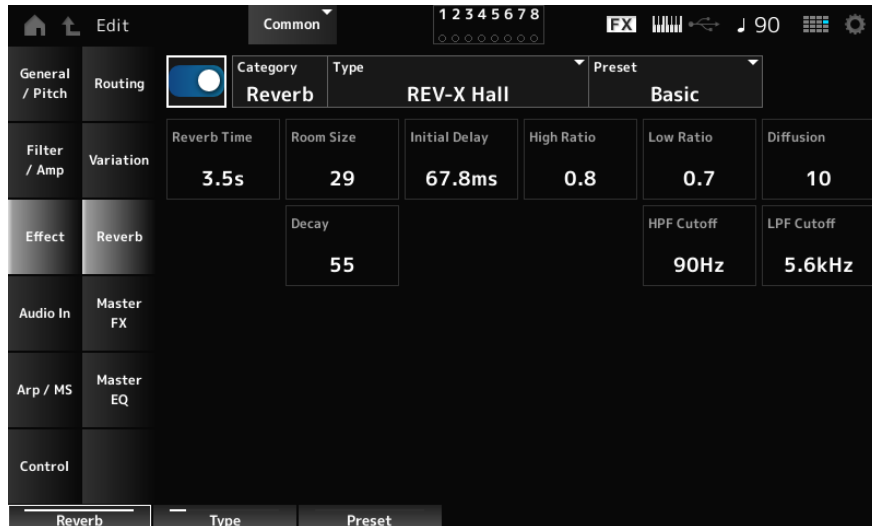

Reverb Switch

Sets the Reverb Effect on or off.

Settings: Off, On

Category (Reverb Category)

Type (Reverb Type)

Sets the category and type of the Reverb Effect.

Settings: Refer to the Effect types

Preset (Reverb Preset Number)

Selects one of the Preset effect parameters for each Effect Type.

Settings: Refer to the Data List

Effect Parameter

The Effect Parameters differ depending on the effect type.

Settings: Refer to the Effect parameters

Master FX

Sets the Master Effect.

Operation

[PERFORMANCE (HOME)] → Common selection → [EDIT/↶] → Effect → Master FX



Master Effect Switch

Sets the Master Effect on or off.

Settings: Off, On

Category (Master Effect Category)

Type (Master Effect Type)

Sets the category and type of the Master Effect.

Settings: Refer to the Effect parameters

Preset (Master Effect Preset Number)

Selects one of the Preset effect parameters for each Effect Type.

Settings: Refer to the Data List

Side Chain (Master Effect Side Chain Part)

Modulator (Master Effect Modulator Part)

Sets the Side Chain (or the Modulator depending on the effect type) for the Master Effects.

This parameter is not available when Master is set to the Modulator Part. In that case, the parameter value will be shown in parenthesis as in "(Master)."

Settings: Part 1–16, A/D, Master, Off

Effect Parameter

The Effect Parameters differ depending on the effect type.

Settings: Refer to the Effect parameters

Master EQ

Sets the Master EQ.

Operation

[PERFORMANCE (HOME)] → Common selection → [EDIT/↶] → Effect → Master EQ



Master EQ (Master EQ Switch)

Sets the Master EQ on or off.

Settings: Off, On

Low Gain (Master EQ Low Gain)

Sets the signal level of the Low band.

Settings: -12dB – +0dB – +12dB

Lo Mid Gain (Master EQ Low Mid Gain)

Sets the signal level of the Lo Mid band.

Settings: -12dB – +0dB – +12dB

Mid Gain (Master EQ Mid Gain)

Sets the signal level of the Mid band.

Settings: -12dB – +0dB – +12dB

Hi Mid Gain (Master EQ High Mid Gain)

Sets the signal level of the Hi Mid band.

Settings: -12dB – +0dB – +12dB

High Gain (Master EQ High Gain)

Sets the signal level of the High band.

Settings: -12dB – +0dB – +12dB

Low Freq (Master EQ Low Frequency)

Sets the frequency of the Low band.

Settings: 32Hz – 2.0kHz

Lo Mid Freq (Master EQ Low Mid Frequency)

Sets the frequency of the Lo Mid band.

Settings: 100Hz – 10kHz

Mid Freq (Master EQ Mid Frequency)

Sets the frequency of the Mid band.

Settings: 100Hz – 10kHz

Hi Mid Freq (Master EQ High Mid Frequency)

Sets the frequency of the Hi Mid band.

Settings: 100Hz – 10kHz

High Freq (Master EQ High Frequency)

Sets the frequency of the High band.

Settings: 500Hz – 16kHz

Low Q (Master EQ Low Q)

Sets the bandwidth of the Low band.

This parameter is available only when Low Shape (Master EQ Low Shape) is set to Peak.

Settings: 0.1–12.0

Lo Mid Q (Master EQ Low Mid Q)

Sets the bandwidth of the Lo Mid band.

Settings: 0.1–12.0

Mid Q (Master EQ Mid Q)

Sets the bandwidth of the Mid band.

Settings: 0.1–12.0

Hi Mid Q (Master EQ High Mid Q)

Sets the bandwidth of the Hi Mid band.

Settings: 0.1–12.0

High Q (Master EQ High Q)

Sets the bandwidth of the High band.

This parameter is available only when High Shape (Master EQ High Shape) is set to Peak.

Settings: 0.1–12.0

Low Shape (Master EQ Low Shape)**High Shape (Master EQ High Shape)**

Sets whether to use Low and High as shelving type (a type that boosts or cuts signals below or above a specific frequency) or peaking type (a type that boosts or cuts signals in a specific frequency band).

Settings: Shelf, Peak

Audio In

Mixing

On the Mixing screen, you can mix the A/D Part (signals from the A/D INPUT jacks) and the Digital Part (signals from the USB [TO HOST] terminal).

*The signal from the USB [TO HOST] terminal is the audio set to Digital L/R in the device port.

Operation

[PERFORMANCE (HOME)] → Common selection → [EDIT/↶] → Audio In → Mixing
[SHIFT] + [A/D INPUT ON/OFF]



Input Mode (A/D Part Input Mode)

Input Mode (Digital Part Input Mode)

Determines the processing method for the input signals at the left and right channels.

Settings: L Mono, R Mono, L+R Mono, Stereo

L Mono: Uses only the left channel.

R Mono: Uses only the right channel.

L+R Mono: Mixes the left and right channels and processes in mono.

Stereo: Processes the stereo input in stereo.

NOTE

If the sound is input only from the [L/MONO] jack, it is processed in mono.

Volume (A/D Part Volume)

Volume (Digital Part Volume)

Sets the volume of the A/D Part or Digital Part.

Settings: 0–127

Pan (A/D Part Pan)

Pan (Digital Part Pan)

Sets the Pan position (in the stereo field) for the A/D Part or Digital Part.

Settings: L63–C (center)–R63

Dry Level (A/D Part Dry Level)

Dry Level (Digital Part Dry Level)

Sets the dry level (or the level of the signals not processed by the System Effect) of the A/D Part or Digital Part.

This parameter is available only when Output Select is set to MainL&R.

Settings: 0–127

Var Send (A/D Part Variation Send)

Var Send (Digital Part Variation Send)

Sets the level of the signals sent from the A/D Part or Digital Part to the Variation Effect.

This parameter is available only when Output Select is set to MainL&R.

Settings: 0–127

Rev Send (A/D Part Reverb Send)

Rev Send (Digital Part Reverb Send)

Sets the level of the signals sent from the A/D Part or Digital Part to the Reverb Effect.

This parameter is available only when Output Select is set to MainL&R.

Settings: 0–127

Output Select (A/D Part Output Select)

Output Select (Digital Part Output Select)

Sets the output destination for the audio signals from the A/D Part or Digital Part.

Settings: MainL&R, (AsgnL&R), USB Stereo, (AsgnL), (AsgnR), USB mono, Off

MainL&R: Outputs in stereo (two channels) to the OUTPUT [L/MONO] and OUTPUT [R] jacks.

USB Stereo: Outputs in stereo (channels 1 and 2, to channels 7 and 8) to the USB [TO HOST] terminal

USB mono: Outputs in mono (channels 1 to 8) to the USB [TO HOST] terminal

Off: No output of the audio signal for the Part.

NOTE

The settings for data compatibility with MONTAGE M are shown below. They are considered Off when set.

- AsgnL&R
- USB Stereo: USB9&10 – USB29&30
- USB mono: USB9 – USB30
- AsgnL
- AsgnR

Routing

On the Routing screen, you can set the effect routing of the A/D Part.

Operation

[PERFORMANCE (HOME)] → Common selection → [EDIT/⟳] → Audio In → Routing

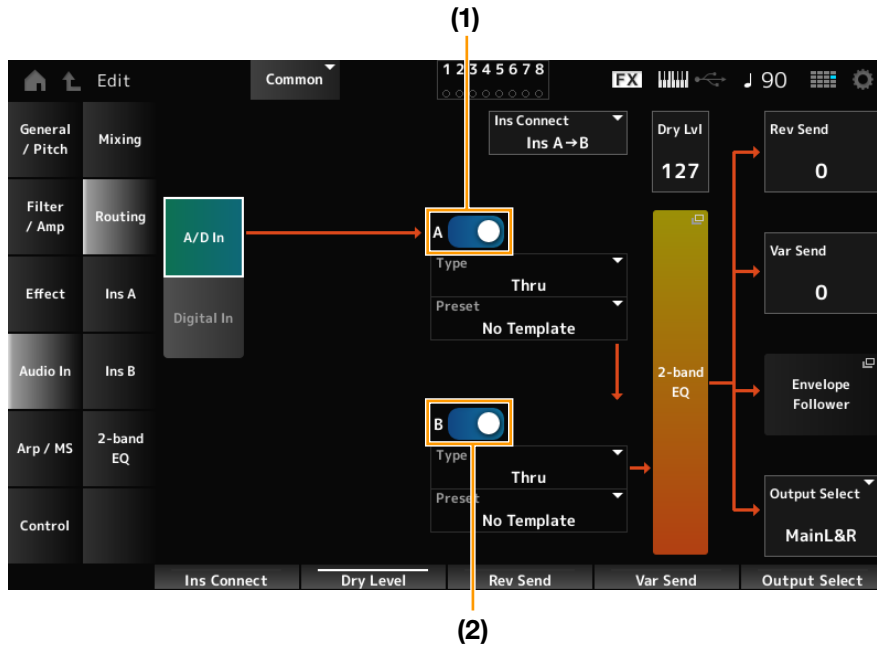

(1) A/D Part Insertion FX A Switch

(2) A/D Part Insertion FX B Switch

A/D In

Digital In

Switches the view between A/D In and Digital In.

When Digital In is selected, only the Digital Part Reverb Send, Digital Part Variation Send, and Digital Part Output Select are available.

A/D Part Insertion FX A Switch

A/D Part Insertion FX B Switch

Turns Insertion Effect A and Insertion Effect B on or off.

Settings: Off, On

Type (A/D Part Insertion Effect A Type)

Type (A/D Part Insertion Effect B Type)

Sets the Effect Type.

Settings: Refer to the Effect types

Preset (A/D Part Insertion Effect A Preset)

Preset (A/D Part Insertion Effect B Preset)

Selects one of the Preset effect parameters for each Effect Type.

By selecting a Preset, you can change the way effects are applied.

Settings: Refer to the Data List

Side Chain (A/D Part Insertion Effect A Side Chain)

Side Chain (A/D Part Insertion Effect B Side Chain)

Modulator (A/D Part Insertion Effect A Modulator)

Modulator (A/D Part Insertion Effect B Modulator)

Sets the Side Chain Part (or the Modulator depending on the effect type) for the Insertion Effect A or Insertion Effect B. This parameter is not available when the Part itself or Master is set to the Modulator. In that case, the parameter value will be shown in parenthesis as in "(Master)."

Settings: Part 1–16, A/D, Master, Off

Ins Connect (A/D Part Insertion Effect Connect Type)

Sets the effect routing for Insertion Effect A and Insertion Effect B. The diagram changes accordingly when the settings are changed.

Settings: Ins A→B, Ins B→A

Dry Level (A/D Part Dry Level)

Sets the dry level (or the level of the signals not processed by the System Effect) of the AD Part.

This parameter is available only when Output Select is set to MainL&R.

Settings: 0–127

2-band EQ

Opens the 2-band EQ 2-band EQ screen for the A/D Part.

Rev Send (A/D Part Reverb Send)

Rev Send (Digital Part Reverb Send)

Sets the level of the signals (or bypass signals) sent from Insertion Effect A or Insertion Effect B to the Reverb Effect.

This parameter is available only when Output Select is set to MainL&R.

Settings: 0–127

Var Send (A/D Part Variation Send)

Var Send (Digital Part Variation Send)

Sets the level of the signals (or bypass signals) sent from Insertion Effect A or Insertion Effect B to the Variation Effect.

This parameter is available only when Output Select is set to MainL&R.

Settings: 0–127

Envelope Follower

Opens the settings screen for Envelope Follower.

Output Select (A/D Part Output Select)

Output Select (Digital Part Output Select)

Sets the output destination for the audio signals.

Settings: MainL&R, (AsgnL&R), USB Stereo, (AsgnL), (AsgnR), USB mono, Off

MainL&R: Outputs in stereo (two channels) to the OUTPUT [L/MONO] and OUTPUT [R] jacks.

USB Stereo: Outputs in stereo (channels 1 and 2, to channels 7 and 8) to the USB [TO HOST] terminal

USB mono: Outputs in mono (channels 1 to 8) to the USB [TO HOST] terminal

Off: No output of the audio signal for the Part.

NOTE

The settings for data compatibility with MONTAGE M are shown below. They are considered Off when set.

- AsgnL&R
- USB Stereo: USB9&10 – USB29&30
- USB mono: USB9 – USB30
- AsgnL
- AsgnR

Ins A, Ins B

On the Ins A and Ins B screens, you can set the Insertion Effects.

Operation

[PERFORMANCE (HOME)] → Common selection → [EDIT/↶] → Audio In → Ins A

[PERFORMANCE (HOME)] → Common selection → [EDIT/↶] → Audio In → Ins B



Insertion FX Switch

Enables the Insertion Effect.

Settings: Off, On

Category (Insertion Effect A Category)

Category (Insertion Effect B Category)

Type (Insertion Effect A Type)

Type (Insertion Effect B Type)

Sets the category and type of the Insertion Effect.

Settings: Refer to the Effect types

Preset (Insertion Effect A Preset)

Preset (Insertion Effect B Preset)

Selects one of the Preset effect parameters for each Effect Type. By selecting a Preset, you can change the way effects are applied.

Settings: Refer to the Data List

Side Chain (Insertion Effect A Side Chain Part)

Side Chain (Insertion Effect B Side Chain Part)

Modulator (Insertion Effect A Modulator Part)

Modulator (Insertion Effect B Modulator Part)

Sets the Side Chain Part (or the Modulator depending on the effect type) for the Insertion Effect A or Insertion Effect B.

This parameter is not available when the Part itself or Master is set to the Modulator. In that case, the parameter value will be shown in parenthesis as in "(Master)."

Settings: Part 1–16, A/D, Master, Off

Effect Parameter

The Effect Parameters differ depending on the effect type.

Settings: Refer to the Effect parameters

2-band EQ

On the 2-band EQ screen, you can set the Part EQ.

Operation

[PERFORMANCE (HOME)] → Common selection → [EDIT/↶] → Audio In → 2-band EQ



EQ1 Type (A/D Part 2-band EQ 1 Type)

EQ2 Type (A/D Part 2-band EQ 2 Type)

Selects the desired EQ type.

Settings: Thru, LPF, HPF, Low Shelf, Hi Shelf, Peak/Dip

Thru: Passes the signals with no effects being applied.

LPF: Cuts the signals above the cutoff frequency.

HPF: Cuts the signals below the cutoff frequency.

Low Shelf: Cuts or boosts the signals below the specified frequency setting.

Hi Shelf: Cuts or boosts the signals above the specified frequency setting.

Peak/Dip: Cuts or boosts the signals at the specified frequency setting.

EQ 1 Freq (A/D Part 2-band EQ 1 Frequency)

EQ 2 Freq (A/D Part 2-band EQ 2 Frequency)

Sets the frequency to be cut or boosted.

This parameter is not available when the EQ Type is set to Thru.

Settings: 63.0Hz–18.0kHz

EQ 1 Gain (A/D Part 2-band EQ 1 Gain)

EQ 2 Gain (A/D Part 2-band EQ 2 Gain)

Sets the signal level of the frequency band set in EQ1 Freq or EQ2 Freq.

This parameter is not available when the EQ Type is set to Thru, LPF, or HPF.

Settings: -12.0dB – +0.0dB – +12.0dB

EQ 1 Q (A/D Part 2-band EQ 1 Q)

EQ 2 Q (A/D Part 2-band EQ 2 Q)

Sets the bandwidth for cutting or boosting the volume of the frequencies set with EQ1 Freq or EQ2 Freq.

This parameter is available only when the EQ Type is set to Peak/Dip.

Settings: 0.1–12.0

Output Level (A/D Part 2-band EQ Output Level)

Sets the output gain of the 2-band EQ.

Settings: -12.0dB – +0.0dB – +12.0dB

Arp Common

On the Arp Common screen, you can set the Arpeggio parameters for the entire Performance.

Operation

[PERFORMANCE (HOME)] → Common selection → [EDIT/↶] → Arp/MS → Arp Common

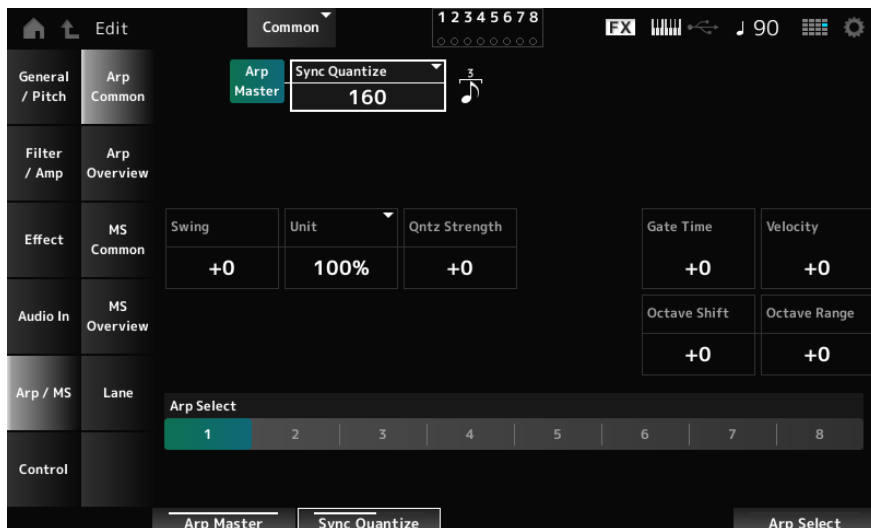

Arp Master (Arpeggio Master Switch)

Sets the Arpeggio for the Performance on or off. This switch is linked to the [ARP] buttons on the top panel.
Settings: Off, On

Sync Quantize (Arpeggio Sync Quantize Value)

Adjusts the timing for starting the next Arpeggio phrase while the first Arpeggio is being played back, when playing back Arpeggio phrases in multiple Parts. When set to Off, the Arpeggio is played back when the Part is played on the keyboard.
Settings: Off, 60 (thirty-second note), 80 (sixteenth note triplet), 120 (sixteenth note), 160 (eighth note triplet), 240 (eighth note), 320 (quarter note triplet), 480 (quarter note) (Numbers indicated here are clock values)

Swing (Swing Offset)

Sets the swing value of the Arpeggio and Motion Sequencer for the Performance.
This is specified as an offset value to Part Swing.
Settings: -120 → 0 → +120

Unit (Common Unit Multiply)

Sets the percentage for stretching or compressing the Arpeggio playback time for the entire Performance.
This parameter affects Parts for which Part Unit (Arpeggio Unit Multiply) is set to Common.
The subdivision of the beat and the tempo will change when you stretch or compress the playback time, so you can create a completely new feel for the originally selected Arpeggio.
Settings: 50%, 66%, 75%, 100%, 133%, 150%, 200%, 266%, 300%, 400%

200%: The playback time is doubled, and the tempo is halved

100%: The playback time is kept unchanged

50%: The playback time is halved, and the tempo is doubled

Qntz Strength (Arpeggio Quantize Strength Offset)

Sets the strength of the quantize setting that is applied to the Arpeggio for the Performance.

This is specified as an offset value to the Qntz Strength (Arpeggio Quantize Strength) of each Part.

Settings: -100→+0→+100

Gate Time (Arpeggio Gate Time Rate Offset)

Sets the Arpeggio Gate Time Rate for the Performance.

This is specified as an offset value to the Gate Time (Arpeggio Gate Time Rate) of each Part.

Settings: -100→+0→+100

Velocity (Arpeggio Velocity Rate Offset)

Sets the Arpeggio Velocity Rate for the Performance.

This is specified as an offset value to the Velocity (Arpeggio Velocity Rate) of each Part.

Settings: -100→+0→+100

Octave Shift (Arpeggio Octave Shift Offset)

Shifts the pitch of the Arpeggio for the Performance in octaves.

This is specified as an offset value to the Octave Shift (Arpeggio Octave Shift) of each Part.

Settings: -20→+0→+20

Octave Range (Arpeggio Octave Range Offset)

Shifts the range of the Arpeggio for the Performance in octaves.

This is specified as an offset value to the Octave Range (Arpeggio Octave Range) of each Part.

Settings: -6→+0→+6

Arp Select (Arpeggio Select)

Selects the Arpeggio.

Settings: 1-8

Arp Overview (Arpeggio Overview)

On the Arp Overview screen, you can set the Arpeggio types from the list of all Parts.

Operation

[PERFORMANCE (HOME)] → Common selection → [EDIT/⟲] → Arp/MS → Arp Overview

(When a selected Part is Common) [SHIFT] + [ARP]

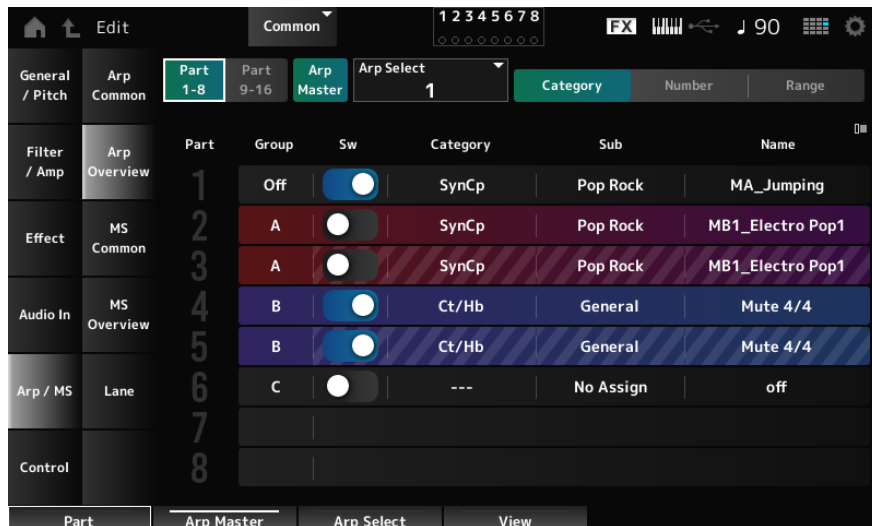

Part 1–8

Part 9–16

Switches the view for Parts.

Settings: Part 1–8, Part 9–16

Arp Master (Arpeggio Master Switch)

Sets the Arpeggio for the Performance on or off.

This switch is linked to the [ARP] buttons on the top panel.

Settings: Off, On

Group (Arpeggio Group)

Sets the Arpeggio Group for using the same Arpeggio on multiple Parts. The Parts set in the same Group will have the same Arpeggio settings.

Arp Select (Arpeggio Select)

Selects the Arpeggio.

Settings: 1–8

Sw (Part Arpeggio Switch)

Sets the Arpeggio of each Part on or off.

Settings: Off, On

■ When View is set to Category

Category (Arpeggio Category)

Sub (Arpeggio Sub Category)

Name (Arpeggio Name)

Settings: Refer to the Data List

■ When View is set to Number

Bank (Arpeggio Bank)

Number (Arpeggio Number)

Name (Arpeggio Name)

Settings: Refer to the Data List

■ When View is set to Range

Name (Arpeggio Name)

Settings: Refer to the Data List

Velocity Limit (Arpeggio Velocity Limit)

Sets the velocity range (lowest and highest values) for Arpeggio playback.

When this is set so that the higher value is first and the lower value is second (for example, 93 to 34), the Arpeggio is played only for velocities of 1 to 34 and 93 to 127.

Settings: 1–127

Note Limit (Arpeggio Note Limit)

Sets the note range (the lowest and the highest notes) for Arpeggio playback.

When the first note specified is higher than the second (for example, C5 to C4), the notes in the ranges C–2 to C4 and C5 to G8 will be played.

Settings: C–2–G8

MS Common (Motion Sequencer Common)

On the MS Common screen, you can set the Motion Sequencer parameters used for the entire Performance.

Operation

[PERFORMANCE (HOME)] → Common selection → [EDIT/↶] → Arp/MS → MS Common

(When a selected Part is Common) [SHIFT] + [MSEQ]

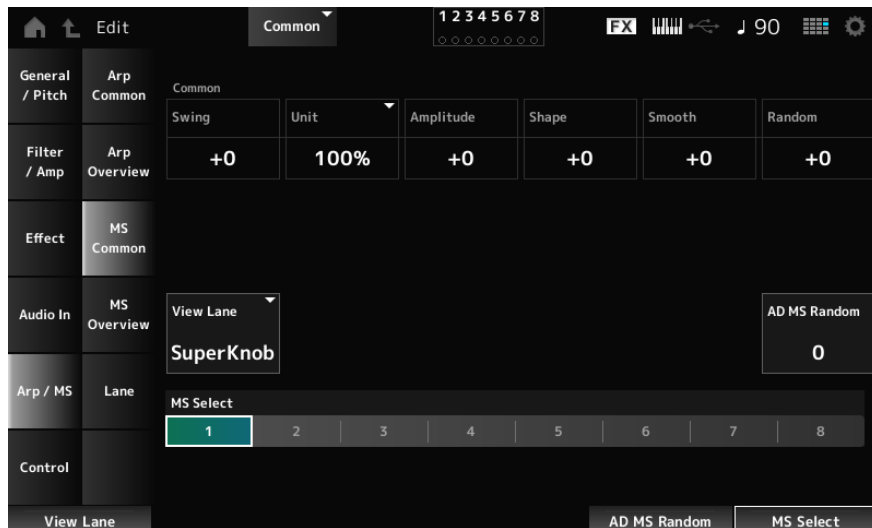

Common Swing (Swing Offset)

Sets the swing value of the Arpeggio and Motion Sequencer for the Performance.

This is specified as an offset value to the Part Swing.

Settings: -120→0→+120

Common Unit (Common Unit Multiply)

Sets the percentage for stretching or compressing the Motion Sequencer playback time for the entire Performance.

This parameter affects Lanes for which Unit is set to Common.

The subdivision of the beat and the tempo will change when you stretch or compress playback time, so you can create a completely new feel for the Motion Sequence you have originally selected.

Settings: 50%, 66%, 75%, 100%, 133%, 150%, 200%, 266%, 300%, 400%

200%: The playback time is doubled, and the tempo is halved

100%: The playback time is kept unchanged

50%: The playback time is halved, and the tempo is doubled

Common Amplitude (Motion Sequencer Amplitude Performance Offset)

Sets the Motion Sequencer Amplitude (or how much the Sequence changes) for the entire Performance.

This parameter value offsets the Amplitude of the Lanes within the Part if MS FX (Lane FX Receive) is set to On.

This is specified as an offset value to the Part Amplitude (Part Motion Sequencer Amplitude) of each Part.

Settings: -127→0→+127

Common Shape (Motion Sequencer Pulse Shape Performance Offset)

Sets the Motion Sequencer Pulse Shape (or the shape of the step curve) for the Performance.

This parameter value offsets the parameters for the Lanes within the Part if MS FX (Lane FX Receive) is set to On for the lane and Control is set to On.

This is specified as an offset value to the Part Shape (Part Motion Sequencer Pulse Shape) of each Part.

Settings: -100→0→+100

Common Smooth (Motion Sequencer Smoothness Performance Offset)

Sets the Motion Sequence Smoothness (or the smoothness of the changes in the sequence over time) for the entire Performance.

This parameter value offsets the Smoothness of the Lanes within the Part if MS FX (Lane FX Receive) is set to On for the Lane.

This is specified as an offset value to the Part Motion Seq Smooth (Part Motion Sequencer Smoothness) of each Part.

Settings: -127--+0--+127

Common Random (Motion Sequencer Randomness Performance Offset)

Sets the Motion Sequencer Randomness (or the randomness of the changes in the step value of the sequence) for the entire Performance.

This parameter value offsets the Randomness of the Lanes within the Performance if MS FX (Lane FX Receive) is set to On for the Lane.

This is specified as an offset value to the Part Motion Seq Random (Part Motion Sequencer Randomness) of each Part.

Settings: -127--+0--+127

View Lane (Motion Seq View Lane)

Sets the Motion Seq Lane that is shown when the View Mode of the Home screen is set to Motion Seq.

Settings: Super Knob, 1-4

AD MS Random (A/D Part Motion Sequencer Randomness)

Sets the randomness of the changes in A/D Part Motion Sequencer Step Value.

Settings: 0-127

MS Select (Motion Sequence Select)

Changes the Motion Sequence selection.

Settings: 1-8

MS Overview (Motion Sequencer Overview)

On the MS Overview screen, you can set the Motion Sequencer from the list of all Parts.

Operation

[PERFORMANCE (HOME)] → Common selection → [EDIT/↶] → Arp/MS → MS Overview

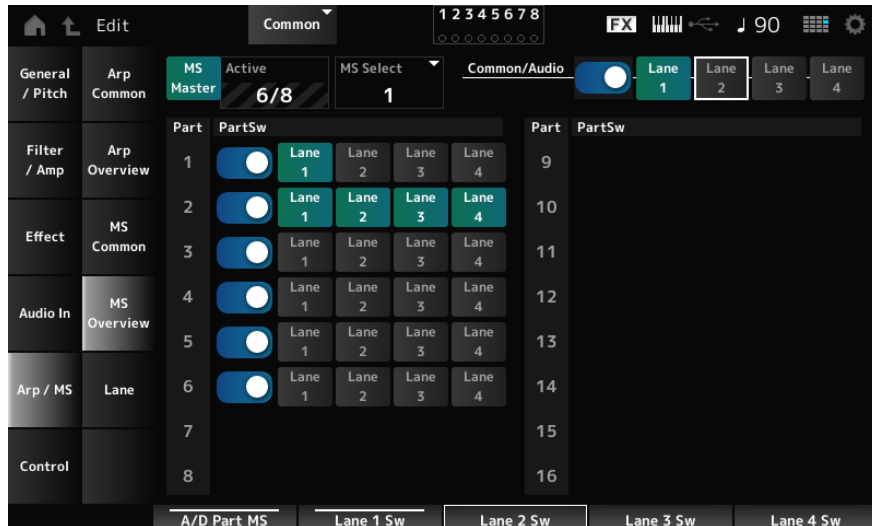

MS Master (Motion Seq Master Switch)

Sets the Motion Sequencer for the entire Performance on or off.

This switch is linked to the [MSEQ] buttons on the top panel.

Settings: Off, On

Active (Active Motion Sequencer)

Shows the number of Lane switches set to On.

The number shown on the right side of the slash (/) indicates the maximum number of Lanes you can simultaneously set to On.

MS Select (Motion Sequence Select)

Changes the Motion Sequence selection.

Settings: 1–8

PartSw (Motion Sequencer Part Switch)

Sets the Motion Sequencer on or off for each Part.

Settings: Off, On

Lane Switch

Sets each Lane on or off.

You can use up to four Motion Sequencer lanes in one Part, or up to eight lanes in an entire Performance.

Settings: Off, On

Lane

On the Lane screen, you can set the parameters for each Motion Sequencer Lane.

Operation

[PERFORMANCE (HOME)] → Common selection → [EDIT/↶] → Arp/MS → Lane

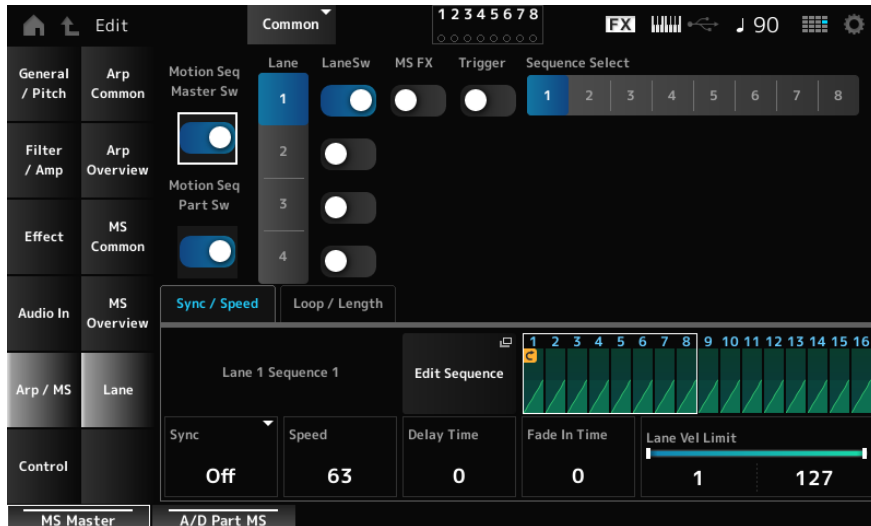

Motion Seq Master Sw (Motion Sequencer Master Switch)

Sets the Motion Sequencer for the entire Performance on or off.

Settings: Off, On

Motion Seq Part Sw (Motion Sequencer Part Switch)

Sets the Motion Sequencer of the Part on or off.

Settings: Off, On

Lane (Lane Select)

Shows the parameters for the selected Lane.

Settings: 1–4

LaneSw (Lane Switch)

Sets each Lane on or off.

You can use up to four Motion Sequencer lanes in one Part, or up to eight lanes in an entire Performance.

When set to Off, the parameters for that lane will not be shown.

Settings: Off, On

MS FX (Lane FX Receive)

Sets the selected Lane to receive the signals from the knobs for changing the Motion Sequencer parameters.

Settings: Off, On

Trigger (Lane Trigger Receive)

Sets the selected Lane to receive the signals from the [MSEQ TRIGGER] button.

When set to On, the Motion Sequence will not be played back unless you press the [MSEQ TRIGGER] button.

Settings: Off, On

Sequence Select (Motion Sequence Select)

Changes the Motion Sequence selection.

Settings: 1–8

Target Sequence

Shows the selected Lanes and sequences.

■ Sync/Speed Tabs

Sync (Lane Sync)

Sets the playback of the Motion Sequence set to the Destination in the Control Assign screen to synchronize to the Performance tempo or beat.

Settings: Off, Tempo, Beat, Lane1 (when Lane2–4 are selected)

Off: Plays back the Lane Motion Sequencer alone

Tempo: Plays back the Lane Motion Sequencer at the Performance tempo.

Beat: Plays back the Motion Sequencer in sync with the beat

Lane1: Plays back the Lane Motion Sequencer in sync with Lane 1

• When Sync is set to Off

Speed (Lane Speed)

Sets the playback speed for the Motion Sequence.

This parameter is available when Sync is set to Off.

Settings: 0–127

Delay Time (A/D Part Motion Seq Lane Key On Delay Time Length)

Sets the delay time for starting the playback of the Motion Sequence.

Settings: 0–127

Fade In Time (A/D Part Motion Seq Lane Fade In Time Length)

Sets the time for the Motion Sequence to reach maximum amplitude.

Settings: 0–127

• When Sync is set to something other than Off

Unit (A/D Part Motion Seq Lane Unit Multiply)

Sets the percentage for stretching or compressing the Motion Sequencer playback time for the selected Lane.

This parameter is available when Sync is set to Tempo or Beat.

Settings: 50%, 66%, 75%, 100%, 133%, 150%, 200%, 266%, 300%, 400%, 600%, 800%, 1200%, 1600%, 2400%, 3200%, 6400%, Common

200%: The playback time is doubled, and the tempo is halved

100%: The playback time is kept unchanged

50%: The playback time is halved, and the tempo is doubled

Common: The value set in the Unit Multiply common to all Parts is applied

Delay Steps (A/D Part Motion Seq Lane Key On Delay Step Length)

Sets the delay time for starting the playback of the Motion Sequence when Sync is set to Tempo or Beat.

Settings: 0–32

Fade In Steps (A/D Part Motion Seq Lane Fade In Step Length)

Sets the time to reach the maximum amplitude for the Motion Sequence when Sync is set to Tempo, Beat, or Lane1.

Settings: 0–32

Lane Vel Limit (Lane Velocity Limit)

Sets the velocity range (lowest and highest values) for playing back the Motion Sequence of the selected Lane.

This parameter is available when Sync is set to Off, Tempo, or Beat.

When the Velocity Limit is set to a range from the highest value to the lowest value, the Motion Sequence will be played back in two velocity ranges: from the maximum to the highest value, and from the lowest value to the minimum.

Settings: 1–127

Edit Sequence

The Motion Sequence Edit screen will open.

Motion Seq Step n Value

Shows the step curve for the selected sequence.

■ Loop/Length Tabs

Key On Reset (Lane Key On Reset)

Resets the Motion Sequence playback when you press any key on the keyboard.

This parameter is available when Sync is set to Off, Tempo, or Beat. This parameter is not available when Trigger is set to On.

Settings: Off, Each-On, 1st-On

Each-On: Each time you play any note, the sequence will be reset and the playback starts from the beginning

1st-On: Playback starts from the beginning at the first note you play. The sequence will not be reset when a second note is played while the first note is being played.

Loop (Lane Loop)

Sets the Motion Sequence to loop playback (in repeats) or one-shot playback.

This parameter is available when Sync is set to Off, Tempo, or Beat.

Settings: Off, On

Loop Start (Lane Loop Start)

Specifies the starting point for the loop playback of the Motion Sequence.

Settings: 1–16 (should be below the Length setting)

Length (Motion Seq Length)

Sets the number of steps in the Motion Sequence.

Settings: 1–16 (should be above the Loop Start setting)

MS Grid (Motion Sequencer Grid)

Sets the length of a step in the Motion Sequence.

Settings: 60, 80, 120, 160, 240, 320, 480

■ Motion Sequence Edit

Opens the setting screen for the Motion Sequence.

You can create a sequence of up to 16 steps.



Loop Start (Lane Loop Start)

Specifies the starting point for the loop playback of the Motion Sequence.

Settings: 1–16 (should be below the Length setting)

Length (Motion Sequence Length)

Sets the Motion Sequence length.

Settings: 1–16 (should be above the Loop Start setting)

MS Grid (Motion Sequencer Grid)

Sets the length of a step in the Motion Sequence.

Settings: 60, 80, 120, 160, 240, 320, 480

Sequence Select (Motion Sequence Select)

Changes the Motion Sequence type selection.

Settings: 1–8

Lane Select

Changes the Lane selection.

Settings: 1–4

Polarity (Motion Sequence Polarity)

Sets the polarity of the Motion Sequence.

Settings: Unipolar, Bipolar

Unipolar: Only positive values are used for the parameter change

Bipolar: Both positive and negative values are used for the parameter change

Amplitude (Motion Sequence Amplitude)

Sets the degree of changes in the Motion Sequence.

Settings: 0–127

Smooth (Motion Sequence Smoothness)

Sets the smoothness of the changes in the Motion Sequence over time.

Settings: 0–127

Job

Calls up the Job menu.

- **Store Sequence**
Saves (stores) the edited Motion Sequence.
- **Load Sequence**
Loads the Motion Sequence.
- **Copy Sequence**
Copies the Motion Sequence.

Motion Sequence Step Value

Sets the value for each step in the Motion Sequence.

You can use Control sliders 1 to 8 to change the values for Steps 1 to 8 and Steps 9 to 16, depending on the cursor position.

Settings: 0–127

Motion Sequence Step Type

Sets the type and direction of each step in the Motion Sequence.

Settings: A, B, Reverse A, Reverse B

Pulse A (Motion Sequence Step Curve Type A)

Pulse B (Motion Sequence Step Curve Type B)

Selects a parameter change curve for Pulse A and Pulse B.

Use the Motion Sequence Step Type to select which of the curve types to use for each step.

The vertical axis represents the time while the horizontal axis represents the step value.

Settings: Standard, Sigmoid, Threshold, Bell, Dogleg, FM, AM, M, Discrete Saw, Smooth Saw, Triangle, Square, Trapezoid, Tilt Sine, Bounce, Resonance, Sequence, Hold, Harmonic, Steps (When a preset bank is selected)

Init Curve 1–32 (When a user bank is selected)

Curve within Library 1–24 (When loading a Library file)

Prm 1 (Motion Sequence Step Curve Parameter 1)**Prm 2 (Motion Sequence Step Curve Parameter 2)**

Adjusts the shape of the step curve in the Motion Sequence. Also, the range for the parameter value differs depending on the Curve Type.

This setting is not available depending on the Curve Type.

Control (Motion Sequence Step Curve Shape Control Switch)

Enables or disables the use of the knobs for controlling the step curve shape of the Motion Sequence.

Shown only when MS FX (Lane FX Receive) is set to On. This setting is not available depending on the Curve Type.

Settings: Off, On

Control

Control Assign

On the Control Assign screen, you can set the Controllers for the Part.

By assigning a parameter (Destination) to a controller (Source), you can control the sound in a large variety of ways. You can use physical controllers such as the Pitch Bend wheel and knobs as well as the Motion Sequencer and Envelope Follower.

Up to 32 controllers can be assigned simultaneously to a Part.

Operation

[PERFORMANCE (HOME)] → Common selection → [EDIT/⟳] → Control → Control Assign

Tap Edit Super Knob on Motion Control → Super Knob

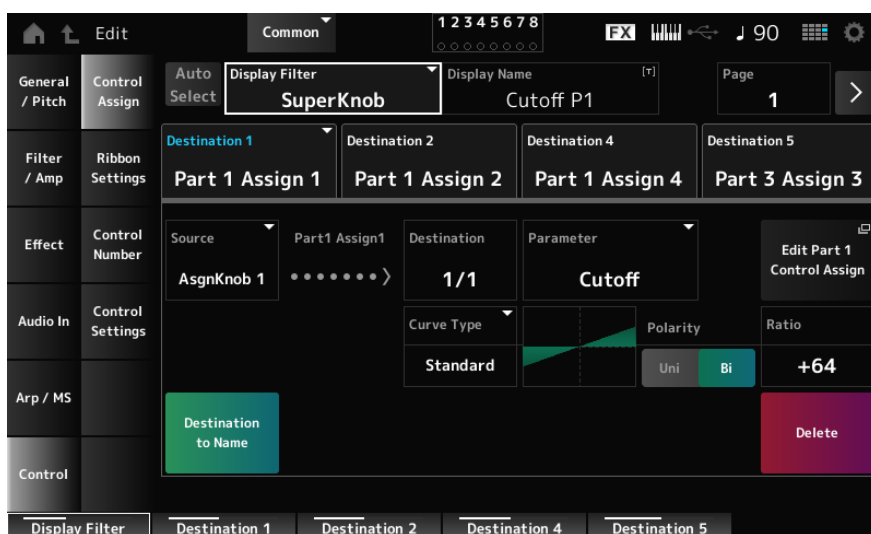

Auto Select

Switches the Auto Select setting of the Display Filter on or off.

When set to On, moving the controller you wish to set to Source automatically sets the Destination controller to the Display Filter.
Settings: Off, On

Display Filter

Selects the controller for showing the settings on the screen.

When you select Super Knob, all settings for Knobs 1 to 8 having the Super Knob Link set to On will be shown.

Settings: PitchBend, ModWheel, Ch. AT, FootCtrl 1, FootCtrl 2, FootSwitch, Ribbon, Breath, AsgnKnob 1–8, Super Knob, AsgnSw 1, AsgnSw 2, MS Lane 1–4, EnvFollow 1–16, EnvFollowAD, EnvFollowMst, All

Display Name (Assignable Knob Name)

This allows you to enter a new name for Knobs 1 to 8. This parameter is not shown when Source is set to something other than AsgnKnob 1–8.

Edit Pitch Bend

General/Pitch → Pitch will open. This parameter is not shown when Source is set to something other than PitchBend.

Edit Motion Sequencer

Opens Arp/MS → Lane. This parameter is not shown when Source is set to something other than MS Lane 1–4.

Edit Envelope Follower

Opens the settings screen for Envelope Follower. This parameter is not shown when Source is set to something other than EnvFollow 1–16, EnvFollowAD, or EnvFollowMst.

Destination

Sets the parameter to the Destination. Tap [+] to add a Destination.

When Source is set to AsgnKnob 1–8, Part1–16 Assign1–8 is added to the settings. In that case, Curve Type and Curve Ratio are not available.

Source

Sets the controller for controlling the parameters set to the Destination.

When Destination is set to Part1–16 Assign1–8, only AsgnKnob 1–8 will be available. Other controllers cannot be used.

Settings: PitchBend, ModWheel, AfterTouch, FootCtrl 1, FootCtrl 2, FootSwitch, Ribbon, Breath, AsgnKnob 1–8, AsgnSw 1, AsgnSw 2, MS Lane 1–4, EnvFollow 1–16, EnvFollowAD, EnvFollowMst

Destination to Name

Copies the parameters set to Destination to Display Name.

This parameter is not shown when Source is set to something other than AsgnKnob 1–8.

Delete

Deletes the selected Destination.

Destination (Part Assignable Knob Destination)

Sets the parameter to show when you try to set Part1–16 Assign1–8 to the Destination and multiple Destinations are already assigned to Part Assign.

Parameter (Part Assignable Knob Parameter)

Sets the Part parameter to the Destination.

Settings: Refer to the Data List

The parameters shown below appear only when Destination 1–32 is set to Part1–16 Assign1–8. Also, only the shortcut buttons are available on the screens when Part Knobs 1–8 cannot be found in Destination.

Edit (Part No.) Control Assign

Opens the Control Assign screen for the selected Part.

Curve Type

Sets the change curve of the parameter set to Destination.

The horizontal axis represents the controller value set in Source while the vertical axis represents the parameter value.

Settings: Standard, Sigmoid, Threshold, Bell, Dogleg, FM, AM, M, Discrete Saw, Smooth Saw, Triangle, Square, Trapezoid, Tilt Sine, Bounce, Resonance, Sequence, Hold, Harmonic, Steps (When a preset bank is selected)
Init Curve 1–32 (When a user bank is selected)
Curve within Library 1–24 (When loading a Library file)

Polarity (Curve Polarity)

Sets the polarity of the curve set in Curve Type.

Settings: Uni, Bi

Uni: Parameter changes occur only within the positive range or the negative range according to the curve shape

Bi: Parameter changes occur both in positive and negative ranges according to the curve shape

Ratio (Curve Ratio)

Sets the ratio of the parameter values.

Settings: -128→0→+127

Param 1 (Curve Parameter 1)

Param 2 (Curve Parameter 2)

Adjusts the curve shape. This setting is not available depending on the Curve Type.

Edit User Curve

Opens the setting screen for User Curve.

Ribbon Settings

Sets the Ribbon controller.

Operation

[PERFORMANCE (HOME)] → Common selection → [EDIT/↶] → Control → Ribbon Settings

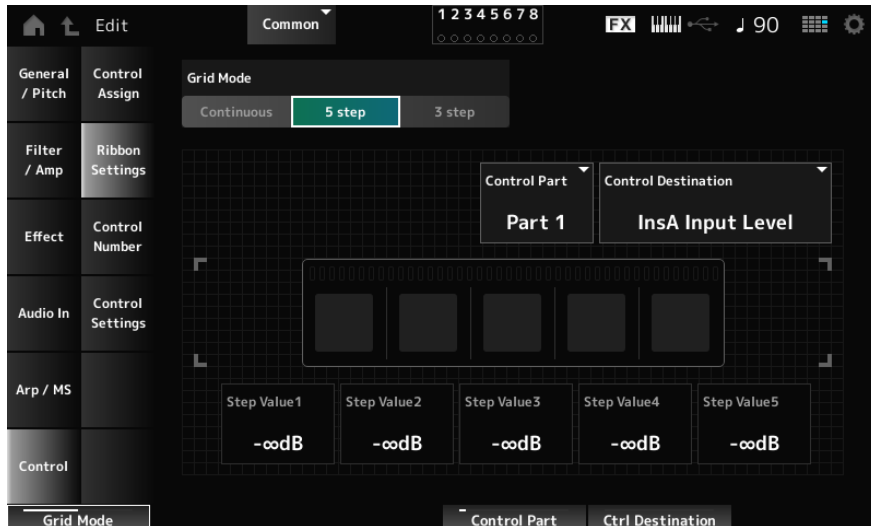

Ribbon Grid Mode

Sets the grid mode for the Ribbon controller.

Settings: Continuous, 5 step, 3 step

NOTE

Set to Continuous if you wish to use the Ribbon Controller setting you have set on the Control Assign screen.

■ Continuous mode

Ribbon Mode (Ribbon Controller Mode)

Sets the way the Ribbon Controller functions.

Settings: Hold, Reset

Hold: Retains the value of the position at which you release your finger from the Ribbon Controller.

Reset: Automatically resets the value to the mid position when you release your finger from the Ribbon Controller.

■ 5 step mode, 3 step mode

Control Part

Selects the Part to be controlled with the Ribbon Controller.

Settings: Common, Part 1–16

Control Destination

Settings: Refer to the Control Box Destination in the Data List

Step Value 1–5

Settings: Depends on the Destination

Control Number

Sets the Control Change number for the entire Performance.

You can assign specific MIDI Control Change numbers to the Knobs on the top panel and controllers on the external device.

NOTE

As for controllers not included on this instrument, you can use an external sequencer or external MIDI controllers.

Operation

[PERFORMANCE (HOME)] → Common selection → [EDIT/↶] → Control → Control Number



Ribbon Ctrl (Ribbon Controller Control Number)

Sets the Control Change number generated by the operation of the Ribbon Controller.

When this instrument receives a MIDI Control Change message of the number set with this parameter from the external device, the message is treated the same as the operation of the built-in Ribbon Controller.

Settings: Off, 1–95

Breath Ctrl (Breath Controller Control Number)

Sets the Control Change number for the Breath Controller to be received from the external device.

When this instrument receives a MIDI Control Change message of the number set with this parameter from the external device, the message is treated the same as the operation of the Breath Controller.

Settings: Off, 1–95

Foot Ctrl 1 (Foot Controller 1 Control Number)

Foot Ctrl 2 (Foot Controller 2 Control Number)

Sets the Control Change number generated by the operation of the Foot Controller connected to the FOOT CONTROLLER jack.

When this instrument receives a MIDI Control Change message of the number set with this parameter from the external device, the message is treated the same as the operation of the Foot Controller.

Settings: Off, 1–95, Super Knob

Assign Sw 1 (Assignable Switch 1 Control Number)

Assign Sw 2 (Assignable Switch 2 Control Number)

Sets the Control Change number generated by the operation of the [ASSIGN 1] and [ASSIGN 2] buttons.

When this instrument receives a MIDI Control Change message of the number set with this parameter from the external device, the message is treated the same as the operation of the [ASSIGN 1] and [ASSIGN 2] buttons.

Settings: Off, 1–95

MS Trigger (Motion Sequencer Trigger Switch Control Number)

Sets the Control Change number generated by the operation of the [MSEQ TRIGGER] button.

When this instrument receives a MIDI Control Change message of the number set with this parameter from the external device, the message is treated the same as the operation of the [MSEQ TRIGGER] button.

Settings: Off, 1–95

MIDI Settings

Opens the MIDI settings screen. The same screen can be opened from [UTILITY] → Settings → MIDI I/O.

Assign Knob (Assignable Knob Control Number)

Sets the Control Change number generated by the operation of Knobs 1 to 8.

When this instrument receives a MIDI Control Change message of the number set with this parameter from the external device, the message is treated the same as the operation of Knobs 1 to 8.

Settings: Off, 1–95

FS Assign (Foot Switch Assign Control Number)

Shows the Control Change number generated by the operation of the footswitch connected to the FOOT SWITCH [ASSIGNABLE] jack. When this instrument receives a MIDI Control Change message of the number set with this parameter from the external device, the message is treated the same as the operation of the footswitch.

Scene CC (Scene Control Change Number)

Shows the Control Change number generated by the operation of the SCENE buttons. When this instrument receives a MIDI Control Change message of the number set with this parameter from the external device, the message is treated the same as the operation of the SCENE buttons.

Super Knob CC (Super Knob Control Change Number)

Shows the Control Change number generated by the operation of the Super Knob. When this instrument receives a MIDI Control Change message of the number set with this parameter from the external device, the message is treated the same as the operation of the Super Knob.

NOTE

- When Scene CC and Super Knob CC are set to Off, System Exclusive (SysEx) is used for handling MIDI messages.
- FS Assign, Scene CC, and Super Knob CC are used for the entire instrument. If desired, change these settings from the Utility MIDI I/O screen.

Control Settings

Sets the controller mode.

Operation

[PERFORMANCE (HOME)] → Common selection → [EDIT/↶] → Control → Control Settings

[SHIFT] + [ASSIGN 1]

[SHIFT] + [ASSIGN 2]

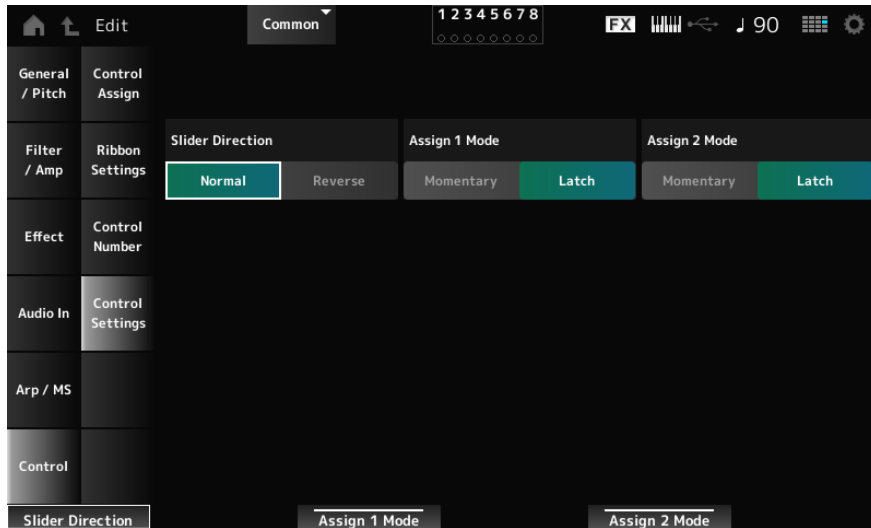

Slider Direction Part 1–8

Sets the direction of the Control sliders 1 to 8 when the slider Mode is set to PART.

Settings: Normal (up from the bottom), Reverse (down from the top)

Assignable Switch 1 Mode

Assignable Switch 2 Mode

Sets the [ASSIGN 1] and [ASSIGN 2] buttons for the Latch or Momentary setting.

Settings: Latch, Momentary

Latch: Sets to On when you press the button and sets to Off when you press the button again.

Momentary: Sets to On while you are holding down the button and sets to Off when you release the button.

Part Edit (AWM2) Part Common Edit Screens

A Normal Part (AWM2) consists of up to 128 elements.

Part Edit (AWM2) includes Part Common Edit (for setting parameters for the entire Part) and Element Edit (for setting parameters for each Element in the Part).

General/Pitch

Part Settings

On the Part Settings screen, you can set general parameters (such as the Part names and tone generation system) for the Part.

Operation

[PERFORMANCE (HOME)] → Part Common selection → [EDIT/↺] → General/Pitch → Part Settings

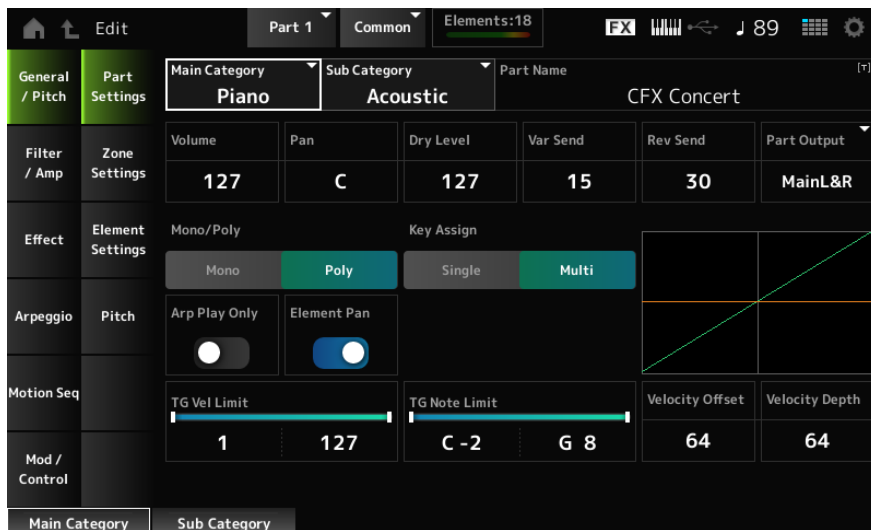

Main Category (Part Main Category)

Sub Category (Part Sub Category)

Sets the Main category and Sub category of the selected Part.

Settings: Refer to the Data List

Part Name

You can save the Part you are editing under a new name, You can use up to 20 alphanumeric characters.

Volume

Sets the volume of the selected Part.

Settings: 0–127

Pan

Adjusts the Pan position (in the stereo field) of the selected Part.

Settings: L63–C (center)–R63

Dry Level

Sets the Dry Level of the selected Part. This parameter is available only when Part Output is set to MainL&R.

Settings: 0–127

Var Send (Variation Send)

Sets the Variation Send of the selected Part. This parameter is available only when Part Output is set to MainL&R.

Settings: 0–127

Rev Send (Reverb Send)

Sets the Reverb Send of the selected Part. This parameter is available only when Part Output is set to MainL&R.

Settings: 0–127

Part Output (Part Output Select)

Sets the output destination for the audio signals of the selected Part.

Settings: MainL&R, (AsgnL&R), USB Stereo, (AsgnL), (AsgnR), USB mono, Off

MainL&R: Outputs in stereo (two channels) to the OUTPUT [L/MONO] and OUTPUT [R] jacks.

USB Stereo: Outputs in stereo (channels 1 and 2, to channels 7 and 8) to the USB [TO HOST] terminal

USB mono: Outputs in mono (channels 1 to 8) to the USB [TO HOST] terminal

Off: No output of the audio signal for the Part.

NOTE

The settings for data compatibility with MONTAGE M are shown below. They are considered Off when set.

- AsgnL&R
- USB Stereo: USB9&10 – USB29&30
- USB mono: USB9 – USB30
- AsgnL
- AsgnR

Mono/Poly

Sets the tone generation mode of the current Part. Mono is for playing single notes, and Poly is for playing multiple simultaneous notes.

When using the Mono setting for playing the keyboard in Legato, you can create a smooth transition of sounds from one note to another.

Settings: Mono, Poly

Key Assign (Key Assign Mode)

Sets how sound is produced when the internal tone generator receives Note On messages of the same sound twice (or more) in a row.

The Multi setting is recommended for most cases. However, the Multi setting uses up many notes in the maximum polyphony, so it is recommended to change to Single if sounds in other Parts are dropped or not played properly.

Settings: Single, Multi

Single: Stops the first note and then plays the same note again. This is convenient for repeating the same note on the same channel

Multi: Plays the second note over the first note. The Multi setting makes rolls sound natural, especially crash cymbals or other percussion instruments having a long decay

Arp Play Only (Arpeggio Play Only)

Sets the Part to be played only with the Arpeggio.

Any Part set to On will be played by the Note On messages sent from the Arpeggio.

Settings: Off, On

Element Pan (Element Pan Switch)

Sets the Pan to On or Off from the Element Edit.

When set to Off, the Pan in the Element Edit will be set to C (center).

Settings: Off, On

TG Note Limit (Note Limit)

Sets the note range (lowest and highest notes) for the Part.

When the first note of Note Limit is set higher than the second (for example, C5 to C4), the notes in the ranges C-2 to C4 and C5 to G8 will be played.

Settings: C-2-G8

TG Vel Limit (Velocity Limit)

Sets the velocity range (lowest and highest values) for the Part.

When this is set so that the higher value is first and the lower value is second (for example, 93 to 34), the notes are played only for velocities of 1 to 34 and 93 to 127.

Settings: 1-127

Velocity Offset (Velocity Sensitivity Offset)

Increases or decreases the velocity value that is sent to the internal tone generator.

Settings: 0-127

When Velocity Depth = 64
and Velocity Offset = 32

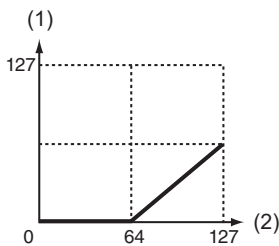

When Velocity Depth = 64
and Velocity Offset = 64

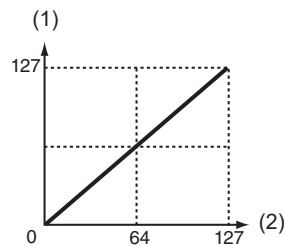

When Velocity Depth = 64
and Velocity Offset = 96

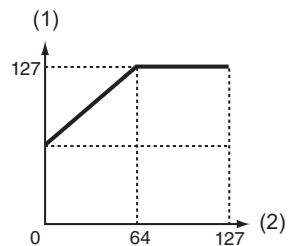

(1) Actual resulting velocity (affecting the tone generator)
(2) Velocity with which you play a note

Velocity Depth (Velocity Sensitivity Depth)

Sets how the level of the velocity value (sent to the internal tone generator) responds to Velocity or the strength of the keystroke.

Settings: 0-127

When Velocity Depth = 64

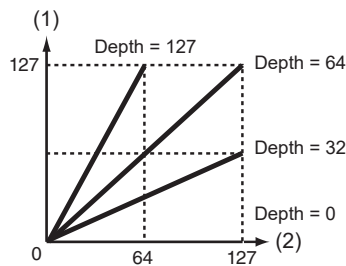

(1) Actual resulting velocity (affecting the tone generator)
(2) Velocity with which you play a note

Zone Settings

On the Zone Settings screen, you can set the parameters for the Zone function.

This function allows you to divide the entire keyboard into a maximum of eight sections (Zones) and independently assign a separate channel to each Zone.

This way, you only need one keyboard to play the sounds of multiple keyboards. You can play multiple Parts on an external multi-timbral sound module or play both the internal tone generator and any connected external sound modules.

Operation

[PERFORMANCE (HOME)] → Part Common selection → [EDIT/↺] → General/Pitch → Zone Settings

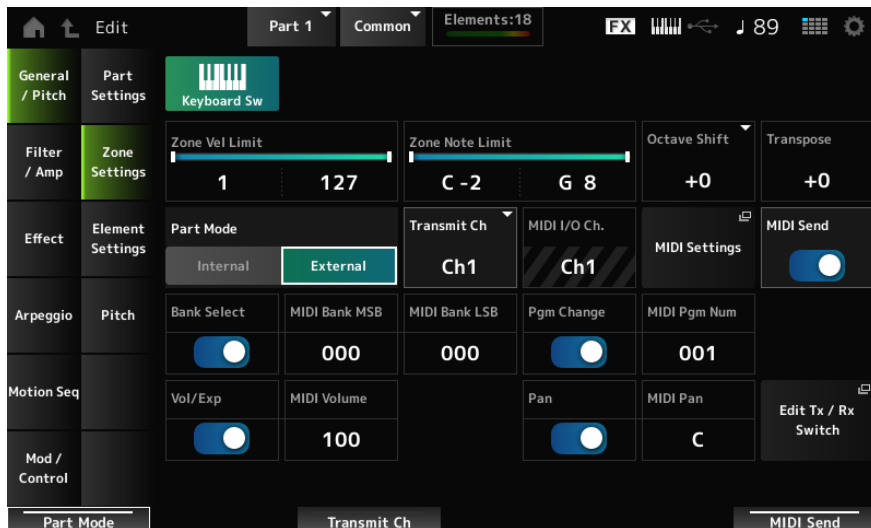

Keyboard Sw (Keyboard Control Switch)

You can set which Parts will play simultaneously by turning each Part's Keyboard Sw (Keyboard Control Switch) on or off. When you select a Part with Common or Keyboard Sw set to On and play the keyboard, the Parts with Keyboard Sw set to On will play simultaneously.

If the Keyboard Sw for the Part is set to Off, when you play the keyboard with that Part selected, those sounds will be played.

Settings: Off, On

Zone Vel Limit (Zone Velocity Limit)

Sets the velocity range (lowest and highest values) for the Zone.

When this is set so that the higher value is first and the lower value is second (for example, 93 to 34), the notes are played only for velocities of 1 to 34 and 93 to 127.

Settings: 1–127

Zone Note Limit

Sets the note range (lowest and highest notes) for the Zone.

When the first note of Note Limit is set higher than the second (for example, C5 to C4), the notes in the ranges C–2 to C4 and C5 to G8 will be played.

Settings: C–2–G8

Octave Shift

Shifts the pitch of the zone in octaves.

Settings: –3–+0 (standard)–+3

Transpose

Shifts the pitch of the zone in semitones.

Settings: -11→+0 (standard)→+11

Part Mode

Switches the Part Mode.

Settings: Internal, External

Internal: Mode that uses the built-in sound engine of the instrument

External: Uses the external sound generator. Any Part set to External does not receive MIDI messages from the external device

Tx/Rx Ch (Transmit/Receive Channel)

Sets the channel for transmitting and receiving MIDI messages when the Part Mode is set to Internal.

Settings: Ch1–Ch16, Off

Transmit Ch

Sets the channel for transmitting and receiving MIDI messages for the Zone when the Part Mode is set to External.

Settings: Ch1–Ch16

MIDI I/O Ch (MIDI Input/Output Channel)

Shows the channel for controlling the Part set to Common and the Part with the Keyboard Sw set to On.

This setting is common to the entire instrument. The setting can be changed on the Utility MIDI Settings screen.

When using Tx/Rx Ch and Transmit Ch, do not use the same channel specified in MIDI I/O Ch. If the same channel is specified, the setting in MIDI I/O Ch will take priority.

Settings: Ch1–Ch16

MIDI Settings

Opens Settings → MIDI I/O on the Utility screen.

MIDI Send

When this parameter is set to On, the MIDI Bank MSB/LSB, MIDI Pgm Num, MIDI Volume, and MIDI Pan settings are transmitted to the external device whenever those parameters are changed. However, the setting is not transmitted when the corresponding transmit switch is set to Off.

This setting is common to all Performances and cannot be set individually for each Performance.

This parameter is available only when Part Mode is set to External.

Settings: Off, On

Bank Select (Transmit Bank Select)

The transmit switch for sending MIDI Bank MSB and MIDI Bank LSB to the external device.

This parameter is available only when Part Mode is set to External.

Settings: Off, On

MIDI Bank MSB

MIDI Bank LSB

Selects the bank for transmitting the Performance selection. This parameter is not available when Bank Select (Transmit Bank Select) is set to Off.

This parameter is available only when Part Mode is set to External.

Settings: 000–127

Pgm Change (Transmit Program Change)

This is the transmit switch for sending Program Change messages to the external device.

This parameter is available only when Part Mode is set to External.

Settings: Off, On

MIDI Pgm Num (MIDI Program Number)

Selects the Program Change number for transmitting the Performance selection.

This parameter is not available when Pgm Change (Transmit Program Change) is set to Off.

This parameter is available only when Part Mode is set to External.

Settings: 001–128

Vol/Exp (Transmit Volume/Expression)

This is the transmit switch for sending the volume setting to the external device.

This parameter is available only when Part Mode is set to External.

Settings: Off, On

MIDI Volume

Sets the volume for transmitting the Performance selection.

This parameter is available only when Part Mode is set to External.

Settings: 0–127

Pan (Transmit Pan)

This is the transmit switch for sending the Pan setting to the external device.

This parameter is available only when Part Mode is set to External.

Settings: Off, On

MIDI Pan

Sets the Pan for transmitting the Performance selection.

This parameter is not available when Pan (Transmit Pan) is set to Off.

Settings: L64–C (Center)–R63

Edit Tx/Rx Switch

Mod/Control → Tx/Rx Switch is displayed.

Element Settings

Sets the maximum number of elements to use.

Operation

[PERFORMANCE (HOME)] → Part Common selection → [EDIT/↺] → General/Pitch → Element Settings



Ex Elem Sw (Extended Element Switch)

Enables the extension of Element capacity.

When set to Off, only up to eight elements are available.

Settings: Off, On

Element Count

Sets the maximum number of elements to use.

Settings: 8–128

Pitch

On the Pitch screen, you can set the pitch for the Part.

Operation

[PERFORMANCE (HOME)] → Part Common selection → [EDIT/↺] → General/Pitch → Pitch

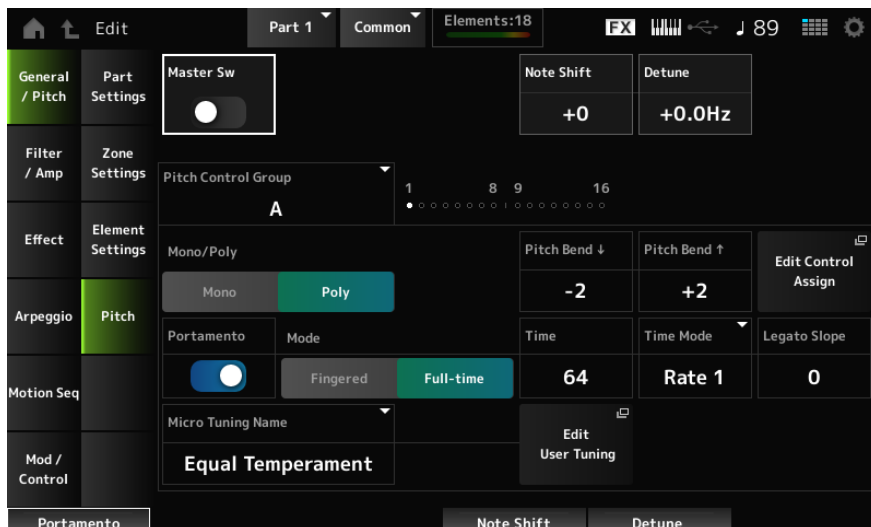

Master Sw (Portamento Master Switch)

Portamento is a function for creating a smooth transition between two notes.

Sets Portamento on or off for Parts having the Portamento Part Switch set to On.

This switch is linked to the [PORTAMENTO] button on the top panel.

Settings: Off, On

Note Shift

Adjusts the pitch in semitones.

Settings: -48+0+48

Detune

Adjusts the pitch of the selected Part in 0.1 Hz increments.

By slightly shifting the pitch, you can detune the sound.

Settings: -12.8Hz+0.0Hz+12.7Hz

Pitch Control Group

Parts assigned to the same group are given the same pitch.

Mono/Poly

Sets the tone generation mode of the current Part. Mono is for playing single notes, and Poly is for playing multiple simultaneous notes.

When using the Mono setting for playing the keyboard in Legato, you can create a smooth transition of sounds from one note to another.

Settings: Mono, Poly

Pitch Bend↓ (Pitch Bend Range Lower)

Pitch Bend↑ (Pitch Bend Range Upper)

Sets the range of the changes created with the pitch bend wheel in semitones.

Settings: -48+0+24

Edit Control Assign

Opens the Control Assign screen with the Display Filter set to PitchBend.

Portamento (Portamento Part Switch)

Sets Portamento on or off for the Part.

Settings: Off, On

Mode (Portamento Mode)

Sets the way Portamento is applied according to your keyboard performance.

Settings: Fingered, Full-time

Fingered: Portamento is applied only when you play legato (playing the next note before releasing the previous one)

Full-time: Portamento is applied at all times

Time (Portamento Time)

Sets the time length (or speed) for the pitch transition of Portamento for the Part.

Settings: 0–127

Time Mode (Portamento Time Mode)

Sets how the pitch changes over time.

Settings: Rate 1, Time 1, Rate 2, Time 2

Rate 1: Pitch changes at a specific rate.

Time 1: Pitch changes at a specific time.

Rate 2: Pitch changes at a specific rate within an octave.

Time 2: Pitch changes at a specific time within an octave.

Legato Slope (Portamento Legato Slope)

Adjusts the attack of the legato (playing the next note before releasing the previous one) when Mono/Poly is set to Mono. When set to Mono, the attack of the note may sound unnatural depending on the attack speed of the waveform assigned to the Part. By setting this parameter low for sounds with short attacks and high for sounds with long attacks, you can adjust the sound to have a natural attack.

Settings: 0–7

Micro Tuning Name

Sets the micro tuning (temperament) for the Part.

For an explanation of each temperament, refer to General/Pitch → Pitch on the Common Edit screen.

Settings: Equal Temperament, Pure Major, Pure Minor, Werckmeister, Kirnberger, Vallotti & Young, 1/4 shift, 1/4 tone, 1/8 tone, Indian, Arabic 1, Arabic 2, Arabic 3

Init Tuning 1–8 (When a user bank is selected)

Library 1–1 – 24–8 (When loading a Library file)

Root (Micro Tuning Root)

Sets the root note for the micro tuning.

This parameter is shown only when a Micro Tuning Name that requires a root note is selected.

Settings: C–B

Edit User Tuning

Opens the User Micro Tuning settings window.

Filter

On the Filter screen, you can set the Filter Envelope Generator (FEG) for the Part.

The FEG lets you set the degree (or level) of changes to the Cutoff Frequency and how those changes evolve over time, starting from the moment you press a key on the keyboard to the moment the sound decays.

Operation

[PERFORMANCE (HOME)] → Part Common selection → [EDIT/↺] → Filter/Amp → Filter

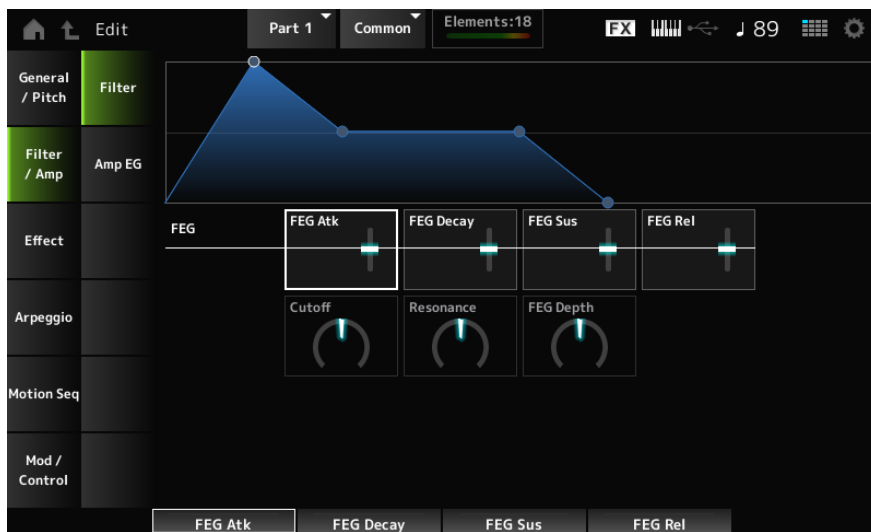

FEG Atk (FEG Attack Time)

Sets the length of time it takes for the sound to change from the moment you press a key to when the Cutoff Frequency reaches the value set at Attack Level (FEG Attack Level).

This is specified as an offset value to the Element FEG.

Settings: -64+0+63

FEG Decay (FEG Decay Time)

Sets the length of time it takes for the Cutoff Frequency to change from the Attack Level (FEG Attack Level). You can control the crispness or the decay speed of the sound.

This is specified as an offset value to the Element FEG.

Settings: -64+0+63

FEG Sus (FEG Sustain Level)

Sets the Cutoff Frequency level that follows the end of the FEG Decay (FEG Decay Time).

This is specified as an offset value to the Element FEG.

Settings: -64+0+63

FEG Rel (FEG Release Time)

Sets the length of time it takes for the Cutoff Frequency to fall to the Release Level (FEG Release Level) when you lift your finger from the key.

This is specified as an offset value to the Element FEG.

Settings: -64+0+63

Cutoff (Filter Cutoff Frequency)

Changes the sound by setting the cutoff frequency of the filter. When the Low Pass Filter is selected, larger values here result in a brighter sound, and smaller values result in a darker sound.

This is specified as an offset value to the cutoff frequency for the Element.

Settings: -64+0+63

Resonance (Filter Resonance)

Adds special characteristics to the sound by adjusting the signal level near the cutoff frequency.

This is specified as an offset value to the Resonance (Filter Resonance) or Width (Filter Width).

Settings: -64+0+63

FEG Depth

Adjusts the depth range of the cutoff frequency controlled by the FEG for the Element.

When it is set to 0, the settings in the Element will be used with no change.

Settings: -64+0+63

Amp EG

On the Amp EG screen, you can set the AEG (Amplitude Envelope Generator) for the Part. By setting the Amp EG, you can set how the volume changes from the moment you press a key on the keyboard to when the sound decays.

Operation

[PERFORMANCE (HOME)] → Part Common selection → [EDIT/↺] → Filter/Amp → Amp EG



AEG Attack (AEG Attack Time)

Sets the length of time it takes for the volume to change from the moment you press a key on the keyboard to when it reaches the maximum.

This is specified as an offset value to the Element AEG.

Settings: -64+0+63

AEG Decay (AEG Decay Time)

Sets the length of time it takes for the volume to change after it has reached the maximum.

This is specified as an offset value to the Element AEG.

Settings: -64+0+63

AEG Sustain (AEG Sustain Level)

Adjusts the volume that is maintained after the AEG Decay (AEG Decay Time).

Settings: -64+0+63

AEG Release (AEG Release Time)

Sets the length of time it takes for the sound to decay after you have released the key.

This is specified as an offset value to the Element AEG.

Settings: -64+0+63

Effect

Routing

On the Routing screen, you can set the effect routing for the Part.

Operation

[PERFORMANCE (HOME)] → Part Common selection → [EDIT/↺] → Effect → Routing

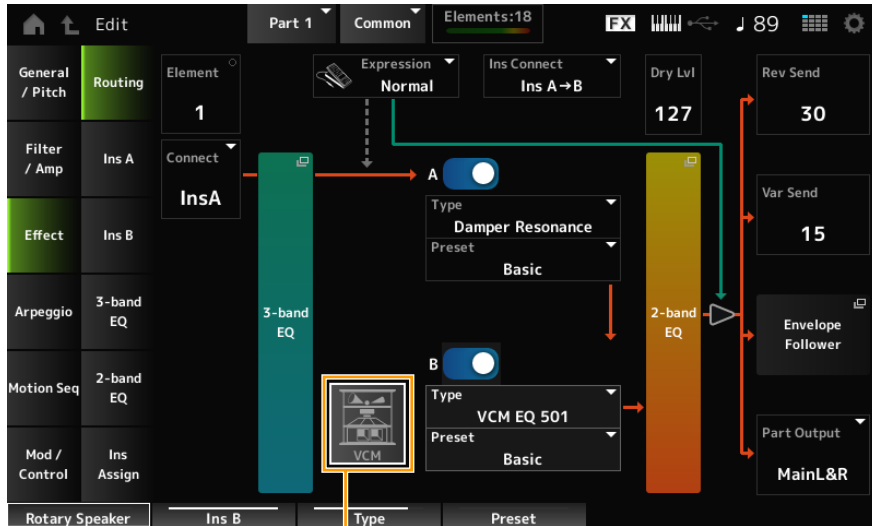

(1)

(1) VCM Rotary Speaker Switch

Element (Element Select)

Shows the name of the selected Element.

When Ex Elem Sw (General/Pitch → Element Settings) is set to Off, or when there are less than eight elements, the numbers 1 to 8 are shown.

Settings: 1–128 (up to the Element Count setting)

Connect (Element Connection Switch)

Sets the Element to be output to Insertion Effect A or Insertion Effect B.

Setting this to Thru bypasses the Insertion Effects.

Settings: Thru, InsA, InsB

3-band EQ

Opens the setting screen for the 3-band EQ.

Expression (Expression Type)

Sets the position in the signal flow when using the Expression pedal.

Settings: Normal, Pre FX

Normal: Applied after the 2-band EQ

Pre FX: Applied before the Insertion Effects. This setting is effective when used with non-linear (the sound changing significantly with the input level) effects such as Distortion

Exp. Curve (Expression Curve)

Sets the way the expression effect is applied with Exp. Curve when Expression Type is set to Pre FX.

Settings: Normal, Organ

Normal: Volume curve of normal characteristics

Organ: Volume curve of the characteristics simulating a vintage organ

VCM Rotary Speaker Switch

Sets the VCM Rotary Speaker effect, which simulates the characteristics of a rotary speaker by utilizing VCM technology.

This parameter is available only when the VCM Rotary Speaker Switch is set to Part 1.

Settings: Off, On

Ins Connect (Insertion Connection Type)

Sets the effect routing for Insertion Effect A and Insertion Effect B. The diagram changes accordingly when the settings are changed.

Settings: Parallel, Ins A→B, Ins B→A

Parallel: (for Normal Part (AWM2) and Drum Part): The output from Insertion Effect A and Insertion Effect B are individually sent to the Master Effect, Master EQ, Reverb, Variation, and Envelope Follower

Ins A→B: The output from Insertion Effect A is sent to Insertion Effect B, and the output from Insertion Effect B is sent to the Master Effect, Master EQ, Reverb, Variation, and Envelope Follower.

Ins B→A: The output from Insertion Effect B is sent to Insertion Effect A, and the output from Insertion Effect A is sent to the Master Effect, Master EQ, Reverb, Variation, and Envelope Follower.

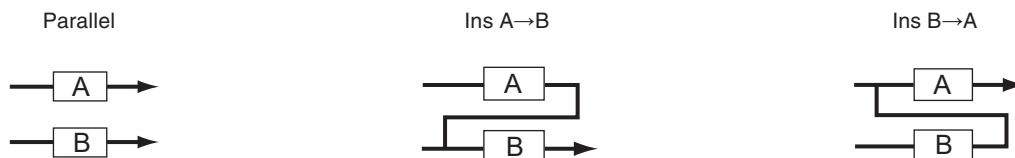

A (Insertion Effect A Switch)

B (Insertion Effect B Switch)

Turns Insertion Effect A or B on or off.

Settings: Off, On

Type (Insertion Effect Type)

Sets the Effect Type.

Settings: Refer to the Effect types

Preset (Insertion Effect Preset)

Selects one of the Preset effect parameters for each Effect Type.

By selecting a Preset, you can change the way effects are applied.

Settings: Refer to the Data List

Side Chain (Insertion Side Chain Part)

Modulator (Insertion Modulator Part)

Sets the Side Chain Part (or the Modulator depending on the effect type) for the Insertion Effect A or Insertion Effect B. This parameter is not available when the Part itself or Master is set to the Modulator. In that case, the parameter value will be shown in parenthesis as in "(Master)."

Settings: Part 1–16, A/D, Master, Off

Dry Level

Sets the dry level (or the level of the signals not processed by the System Effect) of the selected Part.

This parameter is available only when Part Output (Part Output Select) is set to MainL&R.

Settings: 0–127

2-band EQ

Opens the setting screen for the 2-band EQ.

Rev Send (Reverb Send)

Sets the level of the signals (or bypass signals) sent from Insertion Effect A or Insertion Effect B to the Reverb Effect. This parameter is available only when Part Output (Part Output Select) is set to MainL&R.

Settings: 0–127

Var Send (Variation Send)

Sets the level of the signals (or bypass signals) sent from Insertion Effect A or Insertion Effect B to the Variation Effect.

This parameter is available only when Part Output (Part Output Select) is set to MainL&R.

Settings: 0–127

Envelope Follower

Opens the settings screen for the Envelope Follower.

Part Output (Part Output Select)

Sets the output destination for the audio signals.

Settings: MainL&R, (AsgnL&R), USB Stereo, (AsgnL), (AsgnR), USB mono, Off

MainL&R: Outputs in stereo (two channels) to the OUTPUT [L/MONO] and OUTPUT [R] jacks.

USB Stereo: Outputs in stereo (channels 1 and 2, to channels 7 and 8) to the USB [TO HOST] terminal

USB mono: Outputs in mono (channels 1 to 8) to the USB [TO HOST] terminal

Off: No output of the audio signal for the Part.

NOTE

The settings for data compatibility with MONTAGE M are shown below. They are considered Off when set.

- AsgnL&R
- USB Stereo: USB9&10 – USB29&30
- USB mono: USB9 – USB30
- AsgnL
- AsgnR

Ins A, Ins B

On the Ins A and Ins B screens, you can set the Insertion Effects.

Operation

[PERFORMANCE (HOME)] → Part Common selection → [EDIT/↺] → Effect → Ins A

[PERFORMANCE (HOME)] → Part Common selection → [EDIT/↺] → Effect → Ins B

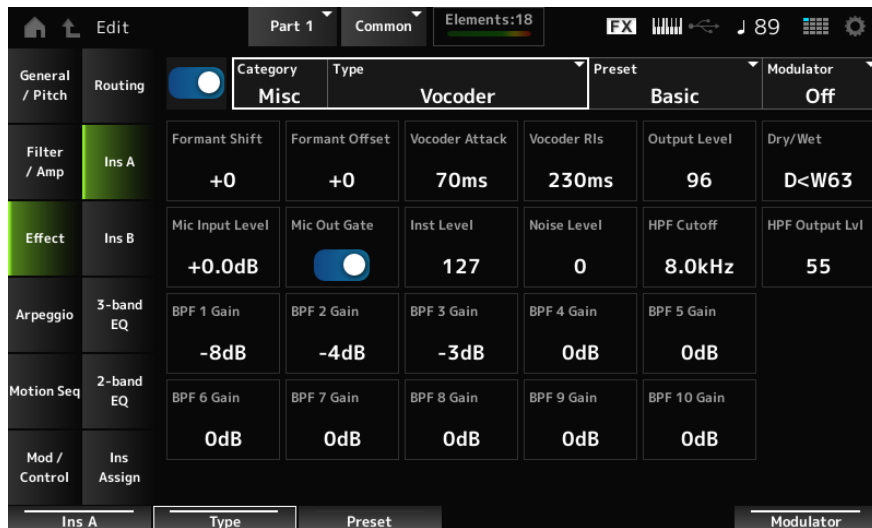

The same as Audio In → [Ins A, Ins B](#) on the Common Edit screen.

3-band EQ

On the 3-band EQ screen, you can set the Part EQ. EQ can be set before the Insertion Effect.

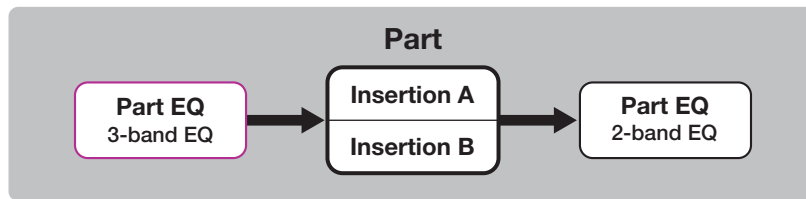

Operation

PERFORMANCE (HOME)] → Part Common selection → [EDIT/↺] → Effect → 3-band EQ



EQ Low Gain (3band EQ Low Gain)

Sets the signal level of the Low band.

Settings: -12.00dB – +0.00dB – +12.00dB

EQ Low Freq (3band EQ Low Frequency)

Sets the frequency of the Low band.

Settings: 50.1Hz–2.00kHz

EQ Mid Gain (3band EQ Mid Gain)

Sets the signal level of the Mid band.

Settings: -12.00dB – +0.00dB – +12.00dB

EQ Mid Freq (3band EQ Mid Frequency)

Sets the frequency of the Mid band.

Settings: 139.7Hz–10.1kHz

EQ Mid Q (3band EQ Mid Q)

Sets the bandwidth of the Mid band.

Settings: 0.7–10.3

EQ Hi Gain (3band EQ High Gain)

Sets the signal level of the High band.

Settings: -12.00dB – +0.00dB – +12.00dB

EQ Hi Freq (3band EQ High Frequency)

Sets the frequency of the High band.

Settings: 503.8Hz–14.0kHz

2-band EQ

On the 2-band EQ screen, you can set the Part EQ. EQ can be set after the Insertion Effect.

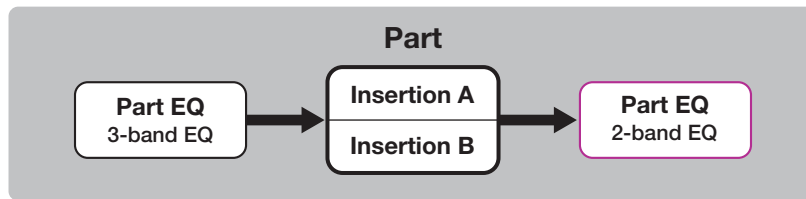

Operation

[PERFORMANCE (HOME)] → Part Common selection → [EDIT/↺] → Effect → 2-band EQ

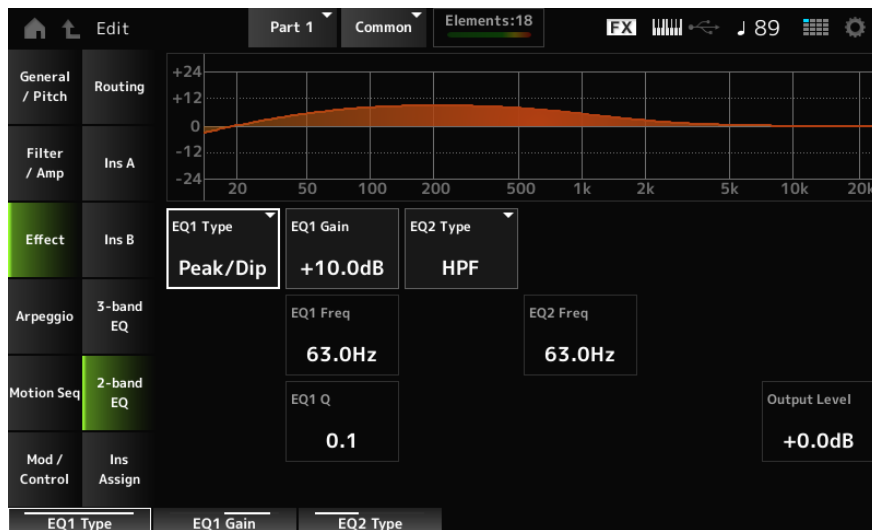

EQ1 Type (2band EQ 1 Type)

EQ2 Type (2band EQ 2 Type)

Selects the desired EQ type.

Settings: Thru, LPF, HPF, Low Shelf, Hi Shelf, Peak/Dip

Thru: Passes the signals with no effects being applied.

LPF: Cuts the signals above the cutoff frequency.

HPF: Cuts the signals below the cutoff frequency.

Low Shelf: Cuts or boosts the signals below the specified frequency setting.

Hi Shelf: Cuts or boosts the signals above the specified frequency setting.

Peak/Dip: Cuts or boosts the signals at the specified frequency setting.

EQ 1 Gain (2band EQ 1 Gain)

EQ 2 Gain (2band EQ 2 Gain)

Sets the signal level of the frequency band set in EQ1 Type (2band EQ 1 Type) or EQ2 Type (2band EQ 2 Type). This parameter is not available when the EQ Type is set to Thru, LPF, or HPF.

Settings: -12.0dB – +0.0dB – +12.0dB

EQ 1 Freq (2band EQ 1 Frequency)

EQ 2 Freq (2band EQ 2 Frequency)

Sets the frequency to be cut or boosted. This parameter is not available when the EQ Type is set to Thru.

Settings: 63.0Hz–18.0kHz

EQ 1 Q (2band EQ 1 Q)

EQ 2 Q (2band EQ 2 Q)

Sets the bandwidth for cutting or boosting the volume of the frequencies set with EQ1 Type (2band EQ 1 Type) or EQ2 Type (2band EQ 2 Type). This parameter is available only when the EQ Type is set to Peak/Dip.

Settings: 0.1–12.0

Output Level (2band EQ Output Level)

Sets the output gain of the 2-band EQ.

Settings: -12.0dB – +0.0dB – +12.0dB

Ins Assign

On the Ins Assign screen, you can enable the Part 9 to 16 Insertion Effect.

Operation

[PERFORMANCE (HOME)] → Part Common selection → [EDIT/↺] → Effect → Ins Assign



Active (Active Part)

This shows the number of Parts whose Insertion Effect switch is set to On. The number to the right of the slash (/) is the maximum number of Insertion Effects that can be turned On simultaneously.

Part 9–16

Enables the Insertion Effect for Parts 9 to 16.

Settings: Off, On

NOTE

The Insertion Effect is always enabled for Parts 1 to 8.

Arpeggio

Common

On the Common screen, you can set the Arpeggio for the entire Part.

Operation

[PERFORMANCE (HOME)] → Part Common selection → [EDIT/↺] → Arpeggio → Common

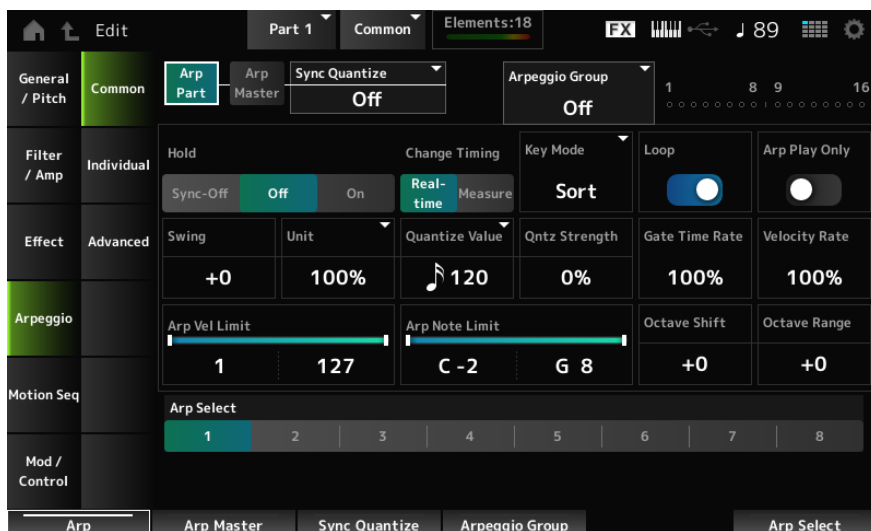

Arp Part (Part Arpeggio Switch)

Sets the Arpeggio for the Part on or off.

Settings: Off, On

Arp Master (Arpeggio Master Switch)

Sets the Arpeggio for the Performance on or off.

Settings: Off, On

Sync Quantize (Arpeggio Sync Quantize Value)

Adjusts the timing for starting the next Arpeggio phrase while the first Arpeggio is being played back, when playing back Arpeggio phrases in multiple Parts.

When set to Off, the Arpeggio is played back when you play the Part on the keyboard.

The value shown here is in clocks.

Settings: Off, 60 (thirty-second note), 80 (sixteenth note triplet), 120 (sixteenth note), 160 (eighth note triplet), 240 (eighth note), 320 (quarter note triplet), 480 (quarter note)

Arpeggio Group

Sets the Arpeggio Group for using the same Arpeggio on multiple Parts.

Indicator

This Indicator is set to On for the Part that is in the same Arpeggio Group as the selected Part.

Hold (Arpeggio Hold)

Enables or disables the Hold function, which continues to repeatedly play back the Arpeggio even after you lift your finger.

Settings: Sync-Off, Off, On

Sync-Off: Repeats Arpeggio playback in the background while your fingers release the keys and resumes playback when you press any key on the keyboard

Off: Plays back the Arpeggio only while any key is being held

On: When you press a key, the Arpeggio will repeat even after you lift your finger

Change Timing (Arpeggio Change Timing)

Sets the timing for changing the Arpeggio type while another Arpeggio phrase is still being played back. You can select Real-time for switching to a new Arpeggio phrase immediately or Measure for switching to a new Arpeggio phrase at the top of the next measure.

Settings: Real-time, Measure

Key Mode (Arpeggio Key Mode)

Sets the way Arpeggio is played back.

Settings: Sort, Thru, Direct, Sort+Drct, Thru+Drct

Sort: Plays back the same Arpeggio regardless of the order of keys played

Thru: Plays back the Arpeggio differently depending on the order of keys played

Direct: Does not play back the Arpeggio. Only your keyboard performance will be played. However, if the Arpeggio data includes Control Change (CC) data such as Pan or Brightness, these effects be reflected. This is effective when the Arpeggio type includes Control Change data or when an Arpeggio in the Control category is selected

Sort+Drct: Plays back the Arpeggio according to the Sort setting, as well as the notes played on the keyboard

Thru+Drct: Plays back the Arpeggio according to the Thru setting, as well as the notes played on the keyboard

Loop (Arpeggio Loop)

Selects loop (repeat) playback while holding the key on the keyboard, or one-shot playback for the Arpeggio every time you press a key.

Settings: Off, On

Arp Play Only (Arpeggio Play Only)

Sets the Part to be played only with the Arpeggio.

The Part set to On will be played by Note On messages sent for the Arpeggio.

Settings: Off, On

Swing

Changes the timing of even-numbered beats (backbeats) counted from the value specified in Quantize Value to add a swing feel to the Arpeggio playback. This setting is useful for creating desired rhythms for playing swing, shuffle, and bounce feels.

Settings: -120--+0--+120

+1 and higher: Moved behind the beat

-1 and lower: Moved ahead of the beat

0: Does not change the even-numbered beats or add any swing feel

Unit (Arpeggio Unit Multiply)

Sets the percentage for stretching or compressing the Arpeggio playback time.

The subdivision of the beat and the tempo will change when you stretch or compress the playback time, so you can create a completely new feel for the originally selected Arpeggio.

Settings: 50%, 66%, 75%, 100%, 133%, 150%, 200%, 266%, 300%, 400%, Common

200%: The playback time is doubled, and the tempo is halved

100%: The playback time is kept unchanged

50%: The playback time is halved, and the tempo is doubled

Common: The value set in the Unit common to all Parts is applied

Quantize Value (Arpeggio Quantize Value)

Sets the reference note for using quantize and swing. The value shown here is in clocks.

Settings: Off, 60 (thirty-second note), 80 (sixteenth note triplet), 120 (sixteenth note), 160 (eighth note triplet), 240 (eighth note), 320 (quarter note triplet), 480 (quarter note)

Qntz Strength (Arpeggio Quantize Strength)

Sets the strength of the Quantize Value (Arpeggio Quantize Value) setting (or how close the notes are to the reference note set in Quantize Value). A setting of 100% shifts the timing completely to that set in Quantize Value, while a setting of 0% results in no quantization.

Settings: 0%–100%

Gate Time Rate (Arpeggio Gate Time Rate)

Sets the Gate Time (or time length for playing the notes) for Arpeggio playback. If the Gate Time is set to a value of 0 as a result, the setting will be changed to a value of 1.

Settings: 0%–200%

Velocity Rate (Arpeggio Velocity Rate)

Sets the velocity rate of the Arpeggio playback. If the Velocity is set to the value of 0 as a result, the setting will be changed to a value of 1. When it is set to a value larger than 128, the setting will be changed to a value of 127.

Settings: 0%–200%

Arp Vel Limit (Arpeggio Velocity Limit)

Sets the velocity range (lowest and highest values) for Arpeggio playback.

When this is set so that the higher value is first and the lower value is second (for example, 93 to 34), the Arpeggio is played only for velocities of 1 to 34 and 93 to 127.

Settings: 1–127

Arp Note Limit (Arpeggio Note Limit)

Sets the note range (the lowest and the highest notes) for Arpeggio playback.

When the first note specified is higher than the second (for example, C5 to C4), the notes in the ranges C–2 to C4 and C5 to G8 will be played.

Settings: C–2–G8

Octave Shift (Arpeggio Output Octave Shift)

Shifts the pitch of the Arpeggio in octaves.

Settings: –10–+0–+10

Octave Range (Arpeggio Octave Range)

Shifts the range of the Arpeggio in octaves.

Settings: –3–+0–+3

Arp Select (Arpeggio Select)

Selects the Arpeggio.

Settings: 1–8

Individual

On the Individual screen, you can set the Arpeggio type parameters for Arp Select (Arpeggio Select) 1–8. Tapping the Arpeggio Type setting calls up the context menu. Selecting Category Search opens the Arpeggio Category Search screen. Selecting Number allows you to specify the Arpeggio Type by number.

Operation

[PERFORMANCE (HOME)] → Part Common selection → [EDIT/↺] → Arpeggio → Individual
(When a selected Part is something other than Common) [SHIFT] + [ARP]

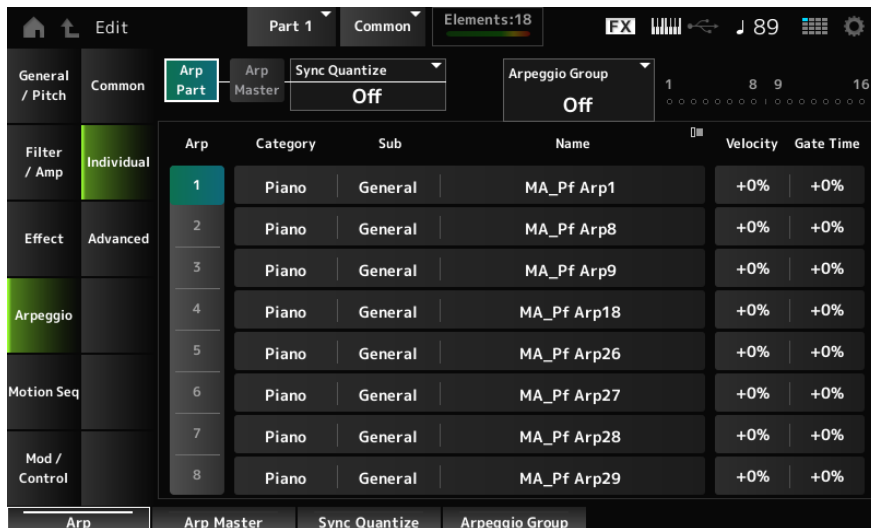

Arp Part (Part Arpeggio Switch)

Arp Master (Arpeggio Master Switch)

Sync Quantize (Arpeggio Sync Quantize Value)

Arpeggio Group

Indicator

The same as the Common screen.

Arp (Arpeggio Select)

Switches the Arpeggio Select.

Settings: 1–8

Category (Arpeggio Category)

Shows the Category of the selected Arpeggio.

Settings: Refer to the Data List

Sub (Arpeggio Sub Category)

Shows the Sub category of the selected Arpeggio.

Settings: Refer to the Data List

Name (Arpeggio Name)

Shows the name of the selected Arpeggio.

Settings: Refer to the Data List

Velocity (Arpeggio Velocity Rate)

Sets the velocity rate of the Arpeggio playback.

If the Velocity is set to the value of 0 as a result, the setting will be changed to a value of 1. When it is set to a value larger than 128, the setting will be changed to a value of 127.

Settings: -100%→+0%→+100%

Gate Time (Arpeggio Gate Time Rate)

Sets the Gate Time (or time length for playing the notes) for Arpeggio playback.

If the Gate Time is set to a value of 0 as a result, the setting will be changed to a value of 1.

Settings: -100%→+0%→+100%

Advanced

On the Advanced screen, you can set the Arpeggio parameters.

Operation

[PERFORMANCE (HOME)] → Part Common selection → [EDIT/↺] → Arpeggio → Advanced

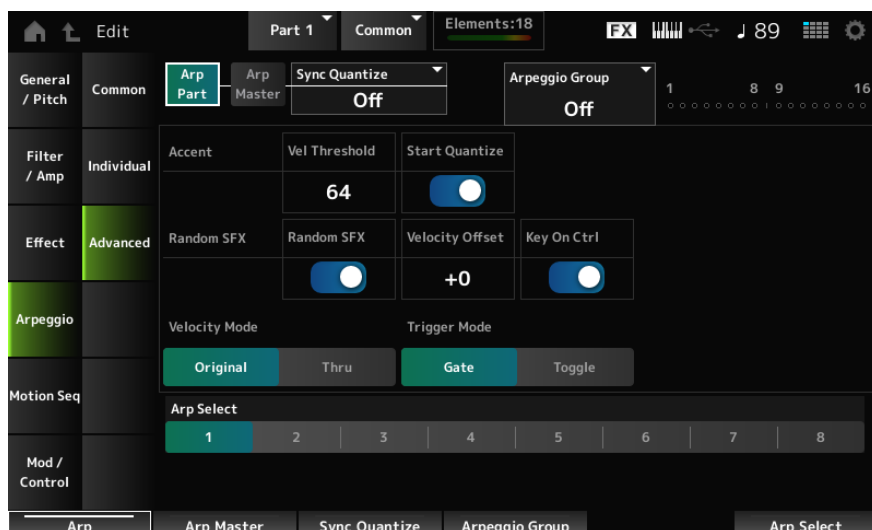

Arp Part (Part Arpeggio Switch)

Arp Master (Arpeggio Master Switch)

Sync Quantize (Arpeggio Sync Quantize Value)

Arpeggio Group

Indicator

The same as the Common screen.

Accent Vel Threshold (Arpeggio Accent Velocity Threshold)

Sets the velocity level for triggering an Accent Phrase. Accent Phrases are sequence phrases that have been programmed to certain types of Arpeggio patterns to be played back only when the keys are played at a fast velocity. When you press a key at a velocity greater than the set value, the Accent Phrase will be played back. If you press a key but it the Accent Phrase doesn't play back, try setting it a little lower and then pressing the key again.

Settings: Off, 1–127

NOTE

For more information on the Arpeggio types that support Accent Phrases, refer to the Data List.

Accent Start Quantize (Arpeggio Accent Start Quantize)

Sets the Accent Phrase to be triggered when a key is pressed at the velocity value larger than the Accent Vel Threshold (Arpeggio Accent Velocity Threshold) (set to On) or triggered at the timing set in the selected Arpeggio type (set to Off).
Settings: Off, On

Random SFX (Arpeggio Random SFX)

Enables the Random SFX function.

The Random SFX function triggers special sounds included in some Arpeggio types. There are various types of special sounds you can use according to the Arpeggio Type. For example, you can use this function to add guitar fret noises when you release your finger from the key.

Settings: Off, On

NOTE

For more information on the Arpeggio types that support this function, refer to the Data List.

Random SFX Velocity Offset (Arpeggio Random SFX Velocity Offset)

Sets the velocity value for triggering special sounds for the Random SFX function.

Settings: -64-+0-+63

Random SFX Key On Ctrl (Arpeggio Random SFX Key On Control)

Sets special sounds to be triggered by the velocity level for pressing keys or by the velocity level automatically set.

Settings: Off, On

Velocity Mode (Arpeggio Velocity Mode)

Sets the velocity for playing back the Arpeggio.

Settings: Original, Thru

Original: Follows the velocity level set in the Arpeggio Type.

Thru: Follows the velocity level of the keystroke

Trigger Mode (Arpeggio Trigger Mode)

Switches the Arpeggio playback method.

Settings: Gate, Toggle

Gate: Starts the Arpeggio playback by pressing a key, and stops it by releasing the key

Toggle: Alternates starting and stopping the Arpeggio playback by pressing a key

Arp Select (Arpeggio Select)

Switches the Arpeggio Select.

Settings: 1-8

Motion Seq

Common

On the Common screen, you can set the Motion Sequencer parameters for the entire Part.

Operation

[PERFORMANCE (HOME)] → Part Common selection → [EDIT/CUR] → Motion Seq → Common

(When a selected Part is something other than Common) [SHIFT] + [MSEQ]

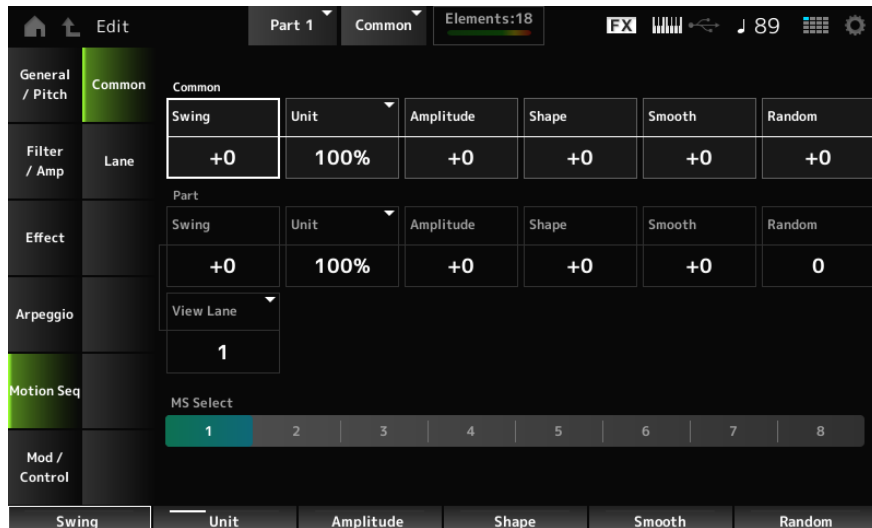

Common Swing (Common Swing Offset)

Sets the swing value of the Arpeggio and Motion Sequencer for the Performance.

This is specified as an offset value to the Part Swing.

Settings: -120→+0→+120

Common Unit (Common Unit Multiply)

Sets the percentage for stretching or compressing the Arpeggio and Motion Sequencer playback time for the entire Performance.

This parameter affects Lanes for which Unit (Lane Unit Multiply) is set to Common.

The subdivision of the beat and the tempo will change when you stretch or compress playback time, so you can create a completely new feel for the Motion Sequence you have originally selected.

Settings: 50%–400%

200%: The playback time is doubled, and the tempo is halved

100%: The playback time is kept unchanged

50%: The playback time is halved, and the tempo is doubled

Common Amplitude (Common Motion Sequencer Amplitude Performance Offset)

Sets the Motion Sequencer Amplitude (or how much the Sequence changes) for the entire Performance.

This parameter value offsets the Amplitude of the Lanes within the Part if MS FX (Lane FX Receive) is set to On.

This is specified as an offset value to the Part Amplitude (Part Motion Sequencer Amplitude) of each Part.

Settings: -127→+0→+127

Common Shape (Common Motion Sequencer Pulse Shape Performance Offset)

Sets the Motion Sequencer Pulse Shape (or the shape of the step curve) for the Performance.

This parameter value offsets the parameters for the Lanes within the Part if MS FX (Lane FX Receive) is set to On for the lane and Control (Motion Sequence Step Curve Shape Control Switch) is set to On.

This is specified as an offset value to the Part Shape (Part Motion Sequencer Pulse Shape) of each Part.

Settings: -100→+0→+100

Common Smooth (Common Motion Sequencer Smoothness Performance Offset)

Sets the Motion Sequence Smoothness (or the smoothness of the changes in the sequence over time) for the entire Performance.

This parameter value offsets the Smoothness of the Lanes within the Part if MS FX (Lane FX Receive) is set to On for the Lane.

This is specified as an offset value to the Part Motion Seq Smooth (Part Motion Sequencer Smoothness) of each Part.

Settings: -127→+0→+127

Common Random (Common Motion Sequencer Randomness Performance Offset)

Sets the Motion Sequencer Randomness (or the randomness of the changes in the step value of the sequence) for the entire Performance.

This parameter value offsets the Randomness of the Lanes within the Performance if MS FX (Lane FX Receive) is set to On for the Lane.

This is specified as an offset value to the Part Motion Seq Random (Part Motion Sequencer Randomness) of each Part.

Settings: -127→+0→+127

Part Swing (Part Swing)

Changes the timing of the even-numbered beats (backbeats) counted from the value specified in MS Grid to add a swing feel to the Motion Sequencer playback. This setting is useful for creating desired rhythms for playing swing, shuffle, and bounce feels.

Settings: -120→+0→+120

+1 and higher: Moved behind the beat

0: Does not change the even-numbered beats or add any swing feel

-1 and lower: Moved ahead of the beat

Part Unit (Arpeggio Unit Multiply)

Sets the percentage for stretching or compressing the Arpeggio playback time for the Part.

The parameter setting is effective when the Unit (Lane Unit Multiply) of each Lane is set to Arp.

Settings: 50%–400%, Common

200%: The playback time is doubled, and the tempo is halved

100%: The playback time is kept unchanged

50%: The playback time is halved, and the tempo is doubled

Common: The value set in the Unit common to all Parts is applied

Part Amplitude (Part Motion Sequencer Amplitude)

Sets the Motion Sequencer Amplitude (or how much the Sequence changes) for the Part. This parameter value offsets the Amplitude of the Lanes within the Part if the MS FX (Lane FX Receive) is set to On for the lane.

This is specified as an offset value to the Amplitude (Motion Sequence Amplitude) for each Lane.

Settings: -127→+0→+127

Part Shape (Part Motion Sequencer Pulse Shape)

Sets the Motion Sequencer Pulse Shape (or the shape of the step curve) for the Part. This parameter value offsets the parameters for the Lanes within the Part if MS FX (Lane FX Receive) is set to On for the lane and Control (Motion Sequence Step Curve Shape Control Switch) is set to On.

This is specified as an offset value to the Prm (Motion Sequence Step Curve Parameter) for each Lane.

Settings: -100→+0→+100

Part Smooth (Part Motion Sequencer Smoothness)

Sets the Motion Sequencer Smoothness for the Part. This parameter value offsets the Smoothness of the Lanes within the Part if MS FX (Lane FX Receive) is set to On for the Lane.

This is specified as an offset value to the Smooth (Motion Sequence Smoothness) for each Lane.

Settings: -127--+0--+127

Part Random (Part Motion Sequencer Randomness)

Sets the Motion Sequencer Randomness for the Part.

Sets randomness of the changes in the Step value of the sequence.

Settings: 0-127

View Lane

Sets the Lane to show when the View Mode of the Home screen is set to Motion Seq View.

MS Select (Motion Sequence Select)

Selects the Motion Sequence to playback.

Settings: 1-8

Lane

On the Lane screen, you can set the parameters for each Motion Sequencer Lane.

Operation

[PERFORMANCE (HOME)] → Part Common selection → [EDIT/↺] → Motion Seq → Lane

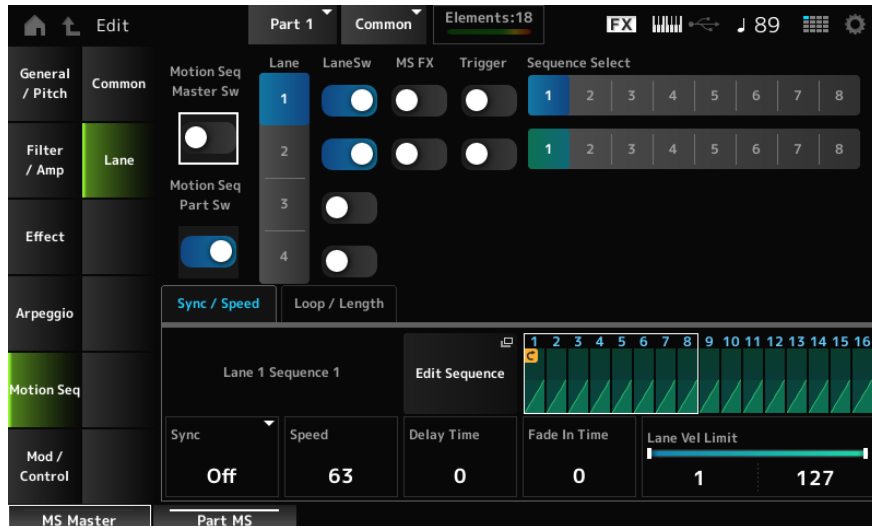

Motion Seq Master Sw (Motion Sequencer Master Switch)

Sets the Motion Sequencer for the entire Performance on or off.

Settings: Off, On

Motion Seq Part Sw (Motion Sequencer Part Switch)

Sets the Motion Sequencer of the Part on or off.

Settings: Off, On

Lane Select

Selects a Lane.

Settings: 1–4

LaneSw (Lane Switch)

Sets each Lane on or off.

You can use up to four Motion Sequencer lanes in one Part, or up to eight lanes in an entire Performance.

When set to Off, the parameters for that lane will not be shown.

Settings: Off, On

MS FX (Lane FX Receive)

Sets the selected Lane to receive the signals from the knobs for changing the Motion Sequencer parameters.

Settings: Off, On

Trigger (Lane Trigger Receive)

Sets the selected Lane to receive the signals from the [MSEQ TRIGGER] button.

When set to On, the Motion Sequence will not be played back unless you press the [MSEQ TRIGGER] button.

Settings: Off, On

Sequence Select (Motion Sequence Select)

Changes the Motion Sequence selection.

Settings: 1–8

Target Sequence

Indicates the Lane and the Sequence.

Edit Sequence

The Motion Sequence Edit screen will open.

You can create a sequence of up to 16 steps.

Motion Seq Step Value

Sets the value for each step in the Motion Sequence.

You can use Control sliders 1 to 8 to change the values for Steps 1 to 8 and Steps 9 to 16, depending on the cursor position.

Settings: 0–127

■ Sync/Speed Tabs

Sync (Lane Sync)

Sets the playback of the Motion Sequence set to the Destination in the Control Assign screen to synchronize to the Performance tempo, beat, or arpeggio.

Settings: Off, Tempo, Beat, Arp, Lane1 (when Lane2–4 are selected)

Off: Plays back the Lane Motion Sequencer alone

Tempo: Plays back the Lane Motion Sequencer at the Performance tempo.

Beat: Plays back in sync with the beat.

Arp: Plays back the Lane Motion Sequencer in sync with the top of the Arpeggio playback.

Lane1: Plays back the Lane Motion Sequencer in sync with Lane 1

• When Sync is set to Off

Speed (Lane Speed)

Sets the playback speed for the Motion Sequence.

This parameter is available when Sync (Lane Sync) is set to Off.

Settings: 0–127

Delay Time (Lane Key On Delay Time Length)

Sets the delay time for starting the playback of the Motion Sequence.

Settings: 0–127

Fade In Time (Lane Fade In Time Length)

Sets the time for the Motion Sequence to reach maximum amplitude.

Settings: 0–127

- **When Sync is set to something other than Off**

Unit (Lane Unit Multiply)

Sets the percentage for stretching or compressing the Motion Sequencer playback time for the selected Lane. This parameter is available when Sync (Lane Sync) is set to Tempo, Beat, or Arp.

Settings: 50%–6400%, Common, Arp

200%: The playback time is doubled, and the tempo is halved

100%: The playback time is kept unchanged

50%: The playback time is halved, and the tempo is doubled

Common: The value set in the Unit common to all Parts is applied

Arp: The value set in the Unit of the Part Arpeggio is applied

Delay Steps (Lane Key On Delay Step)

Sets the delay time for starting the playback of the Motion Sequence when Sync (Lane Sync) is set to Tempo, Beat, or Arp.

Settings: 0–32

Fade In Steps (Lane Fade In Step Length)

Sets the time to reach the maximum amplitude for the Motion Sequence when Sync (Lane Sync) is set to Tempo, Beat, Arp, or Lane1.

Settings: 0–32

Lane Vel Limit (Lane Velocity Limit)

Sets the velocity range (lowest and highest values) for playing back the Motion Sequence of the selected Lane.

This parameter is available when Sync (Lane Sync) is set to Off, Tempo, Beat, or Arp.

When the Velocity Limit is set to a range from the highest value to the lowest value, the Motion Sequence will be played back in two velocity ranges: from the maximum to the highest value, and from the lowest value to the minimum.

Settings: 1–127

■ Loop/Length Tabs

Key On Reset (Lane Key On Reset)

Resets the Motion Sequence playback when you press any key on the keyboard.

This parameter is available when Sync (Lane Sync) is set to Off, Tempo, or Beat. This parameter is not available when Trigger is set to On.

Settings: Off, Each-On, 1st-On

Each-On: Each time you play any note, the sequence will be reset and the playback starts from the beginning

1st-On: Playback starts from the beginning at the first note you play. When the second note is played while the first note is held, playback will not be reset

Loop (Lane Loop)

Sets the Motion Sequence to loop playback (in repeats) or one-shot playback.

This parameter is available when Sync (Lane Sync) is set to Off, Tempo, Beat, or Arp.

Settings: Off, On

Loop Start (Motion Sequence Loop Start)

Sets the step for starting playback the second time or later when repeating Motion Sequence playback.

Settings: 1–Length (Motion Sequence Length)

Length (Motion Sequence Length)

Sets the number of steps in the Motion Sequence.

Settings: Loop Start (Motion Sequence Loop Start)–16

MS Grid (Motion Sequencer Grid)

Sets the length of a step in the Motion Sequence.

Settings: 60, 80, 120, 160, 240, 320, 480

Control Assign

On the Control Assign screen, you can set the Controllers for the Part.

By assigning a parameter (Destination) to a controller (Source), you can control the sound in a large variety of ways. You can use physical controllers such as the Pitch Bend wheel and knobs as well as the Motion Sequencer and Envelope Follower.

Up to 32 controllers can be assigned simultaneously to a Part.

Operation

[PERFORMANCE (HOME)] → Part Common selection → [EDIT/↺] → Mod/Control → Control Assign



When Display Filter is set to Super Knob, tapping [+] shows the message in the upper area of the display and automatically adds the Control Assign settings for the Common Edit.

NOTE

When there are no assignable knobs available, [+] will not be shown.

Auto Select

Switches the Auto Select setting of the Display Filter on or off.

When set to On, moving the controller you wish to set to Source automatically sets the controller to the Display Filter.

Settings: Off, On

Display Filter

Selects the controller for showing the settings on the screen.

When you select Super Knob, all settings having the Super Knob Link set to On will be shown.

Settings: PitchBend, ModWheel, Ch. AT, FootCtrl 1, FootCtrl 2, FootSwitch, Ribbon, Breath, AsgnKnob 1–8, Super Knob, AsgnSw 1, AsgnSw 2, MS Lane 1–4, EnvFollow 1–16, EnvFollowAD, EnvFollowMst, All

NOTE

If the controller set to Display Filter is used by other Parts, the corresponding PART buttons will flash.

Edit Pitch Bend

This calls up the Pitch settings screen. General/Pitch → Pitch will open.

This parameter is not shown when Source is set to something other than PitchBend.

Display Name (Assignable Knob Name)

This allows you to enter a new name for Knobs 1 to 8.

This parameter is not shown when Source is set to something other than AsgnKnob 1–8.

Edit Motion Sequencer

Opens Motion Seq → Lane for the selected Part.

You can create a sequence of up to 16 steps.

This parameter is not shown when Source is set to something other than MS Lane 1–4.

Edit Envelope Follower

Opens the settings screen for the Envelope Follower.

This parameter is not shown when Source is set to something other than EnvFollow 1–16, EnvFollowAD, or EnvFollowMst.

Page

Selects the next page when there are more than four Destinations. The next page does not appear when the Destinations are four or fewer.

Settings: 1–8

Destination

Sets the parameter to the Destination. Tap [+] to add a Destination.

Source

Sets the controller for controlling the parameters set to the Destination.

Settings: PitchBend, ModWheel, Ch. AT, FootCtrl 1, FootCtrl 2, FootSwitch, Ribbon, Breath, AsgnKnob 1–8, AsgnSw 1, AsgnSw 2, MS Lane 1–4, EnvFollow 1–16, EnvFollowAD, EnvFollowMst

Element Sw (Element Switch) 1–128

This parameter is shown only when the selected Destination is related to Elements.

You can set the controller setting for each Element on or off.

When General/Pitch → Element Settings Ex Elem Sw is set to On, you can select a different group of eight displayed switch numbers.

However, the actual range of numbers you can use in the switch depends on the value set in the Element Count on the General/Pitch → Element Settings screen.

(Example: If the Element Count is set to 30, the Groups that can be selected are 25–32).

Settings: (Each switch) Off, On, (Displayed switch numbers changed) 1–8, 9–16, ..., 121–128

Curve Type

Sets the change curve of the parameter set to Destination.

The horizontal axis represents the controller value set in Source while the vertical axis represents the parameter value set in Destination.

Settings: Standard, Sigmoid, Threshold, Bell, Dogleg, FM, AM, M, Discrete Saw, Smooth Saw, Triangle, Square, Trapezoid, Tilt Sine, Bounce, Resonance, Sequence, Hold, Harmonic, Steps (When a preset bank is selected)
Init Curve 1–32 (When a user bank is selected)
Curve within Library 1–24 (When loading a Library file)

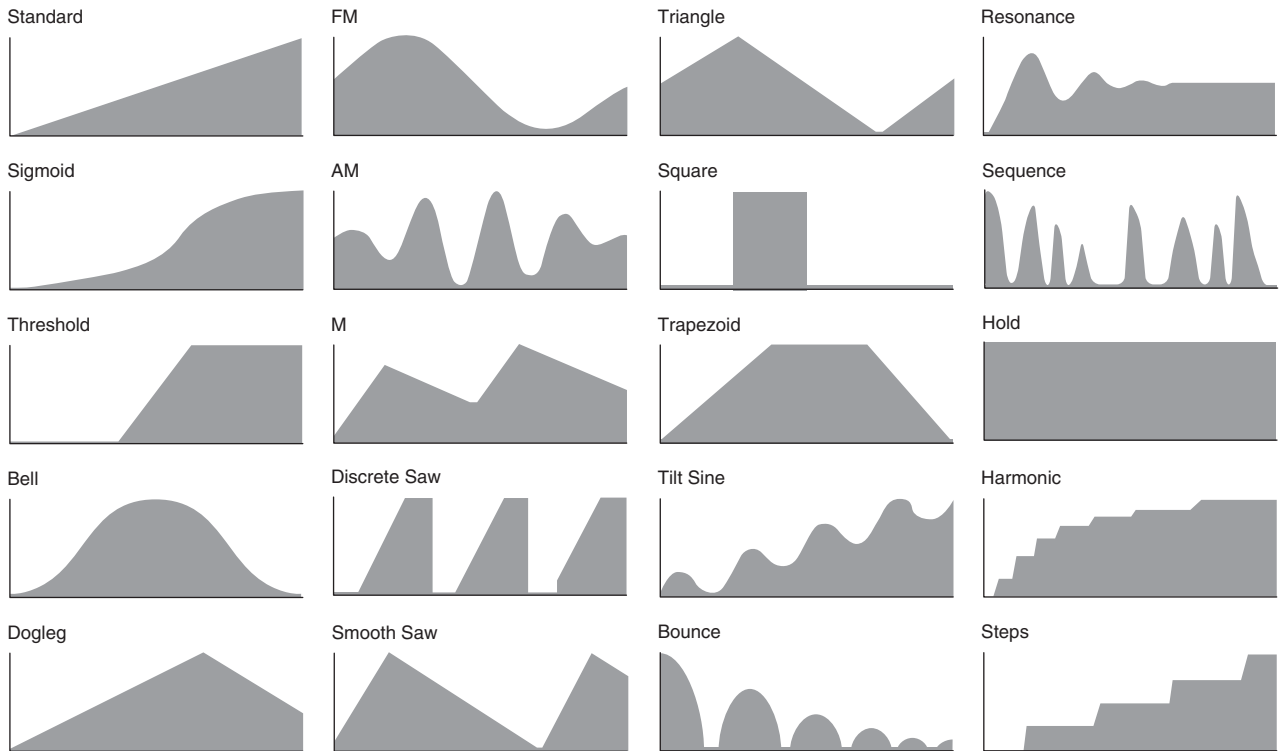

Polarity (Curve Polarity)

Sets the polarity of the curve set in Curve Type.

Settings: Uni, Bi

Uni: Parameter changes occur only within the positive range or the negative range according to the curve shape

Bi: Parameter changes occur both in positive and negative ranges according to the curve shape

Ratio (Curve Ratio)

Sets the ratio of the parameter values.

Settings: -128→+0→+127

Param 1 (Curve Parameter 1)

Param 2 (Curve Parameter 2)

Adjusts the curve shape.

This setting is not available depending on the curve type.

Destination to Name

Copies the parameters set to Destination to Display Name.

This parameter is not shown when Source is set to something other than AsgnKnob 1–8.

Edit User Curve

The User Curve Edit screen will open.

Edit Common Control Assign

Opens Control → Control Assign on the Common Edit screen.

Delete

Deletes the selected Destination.

After Touch

Operation

[PERFORMANCE (HOME)] → Part Common selection → [EDIT/↺] → Mod/Control → After Touch

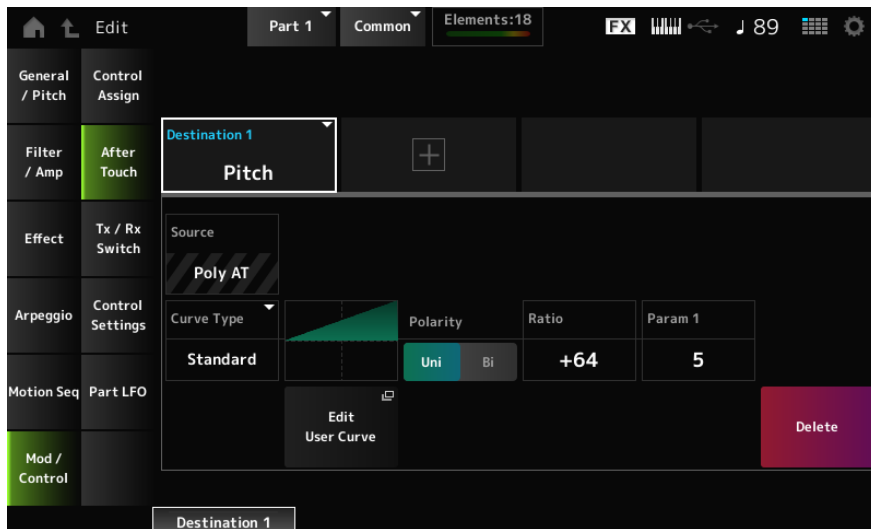

Destination

Sets the parameter for the Destination. Tap [+] to add a Destination.

Source

Cannot be changed from this screen. This parameter is fixed to Poly AT.

Element Sw (Element Switch) 1–128

Curve Type

Polarity (Curve Polarity)

Ratio (Curve Ratio)

Edit User Curve

Delete

The same as Mod/Control → [Control Assign](#).

Tx/Rx Switch

On the Tx/Rx Switch screen, you can set the switch for transmitting or receiving MIDI messages (such as Control Change) on or off.

NOTE

When CC (Control Change) is set to Off, the parameters related to Control Change messages cannot be set.

Operation

[PERFORMANCE (HOME)] → Part Common selection → [EDIT/↺] → Mod/Control → Tx/Rx Switch

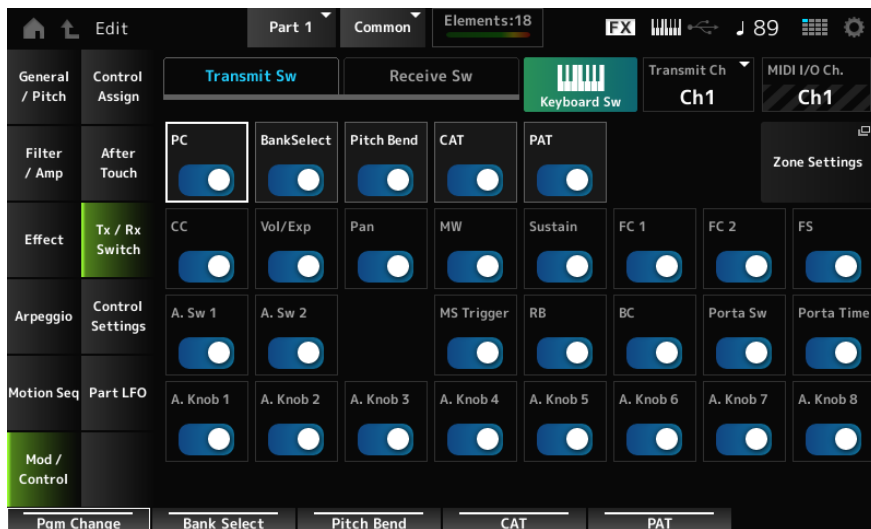

Transmit Sw (Transmit Switch)

Shows the transmit switch.

This parameter is available only when Part Mode is set to External or when Keyboard Sw is set to Off.

Receive Sw (Receive Switch)

Shows the receive switch.

Keyboard Sw (Keyboard Control Switch)

Sets the Parts to be played simultaneously.

When you select a Part with Common or Keyboard Sw set to On and play the keyboard, the Parts with Keyboard Sw set to On will play simultaneously.

If the Keyboard Sw for the Part is set to Off, when you play the keyboard with that Part selected, those sounds will be played.

Settings: Off, On

Tx/Rx Ch (Transmit/Receive Channel)

Sets the channel for transmitting and receiving MIDI messages when Part Mode is set to Internal.

Settings: Ch1–Ch16, Off

Transmit Ch.

Sets the channel for transmitting MIDI messages when Part Mode is set to External.

Settings: Ch1–Ch16

MIDI I/O Ch. (MIDI In-Out Channel)

Shows the channel for transmitting and receiving MIDI messages.

Zone Settings

This calls up the Zone settings screen.

The same as General/Pitch → [Zone Settings](#).

PC (Program Change)

Sets the transmission and reception of Program Change messages on or off.

Settings: Off, On

BankSelect (Bank Select)

Sets the transmission and reception of Bank Select MSB and LSB messages on or off. This parameter is not available when CC (Control Change) is set to Off.

Settings: Off, On

Pitch Bend

Sets the transmission and reception of MIDI Pitch Bend messages on or off.

Settings: Off, On

CAT (Channel After Touch)

Sets the transmission and reception of Channel Aftertouch on or off.

Settings: Off, On

PAT (Polyphonic After Touch)

Sets the transmission and reception of Polyphonic Aftertouch on or off.

Settings: Off, On

CC (Control Change)

Sets the transmission and reception of Control Change messages on or off.

Settings: Off, On

Vol/Exp (Volume/Expression)

Sets the transmission and reception of the Volume setting on or off. This parameter is not available when CC (Control Change) is set to Off.

Settings: Off, On

Pan

Sets the transmission and reception of the Pan setting on or off. This parameter is not available when CC (Control Change) is set to Off.

Settings: Off, On

MW (Modulation Wheel)

Sets the transmission and reception of MIDI Modulation wheel messages on or off. This parameter is not available when CC (Control Change) is set to Off.

Settings: Off, On

Sustain

Sets the transmission and reception of MIDI Sustain and Sostenuto messages on or off. This parameter is not available when CC (Control Change) is set to Off.

Settings: Off, On

FC1 (Foot Controller 1)

FC2 (Foot Controller 2)

Sets the transmission and reception of MIDI messages for the separately sold foot controllers on or off. This parameter is not available when CC (Control Change) is set to Off.

Settings: Off, On

FS (Foot Switch)

Sets the transmission and reception of MIDI messages for the separately sold foot switch on or off. This parameter is not available when CC (Control Change) is set to Off.

Settings: Off, On

A. Sw 1 (Assignable Function Switch 1)

A. Sw 2 (Assignable Function Switch 2)

Sets the transmission and reception of MIDI messages for the [ASSIGN 1] and [ASSIGN 2] buttons on or off. This parameter is not available when CC (Control Change) is set to Off.

Settings: Off, On

MS Trigger (Motion Sequencer Trigger)

Sets the transmission and reception of MIDI messages for the [MSEQ TRIGGER] button on or off. This parameter is not available when CC (Control Change) is set to Off.

Settings: Off, On

RB (Ribbon Controller)

Sets the transmission and reception of MIDI Ribbon Controller messages on or off. This parameter is not available when CC (Control Change) is set to Off.

Settings: Off, On

BC (Breath Controller)

Sets the transmission and reception of MIDI Breath Controller messages on or off. This parameter is not available when CC (Control Change) is set to Off.

Settings: Off, On

Porta Sw (Portamento Switch)

Sets the transmission and reception of MIDI messages for the [PORTAMENTO] button on or off. This parameter is not available when CC (Control Change) is set to Off.

Settings: Off, On

Porta Time (Portamento Time)

Sets the transmission and reception of MIDI messages for the PORTAMENTO [TIME] knob on or off. This parameter is not available when CC (Control Change) is set to Off.

Settings: Off, On

A. Knob 1–8 (Assignable Knob)

Sets the transmission and reception of MIDI messages for Knobs 1 to 8 on or off. This parameter is not available when CC (Control Change) is set to Off.

Settings: Off, On

Control Settings

Operation

[PERFORMANCE (HOME)] → Part Common selection → [EDIT/↺] → Mod/Control → Control Settings

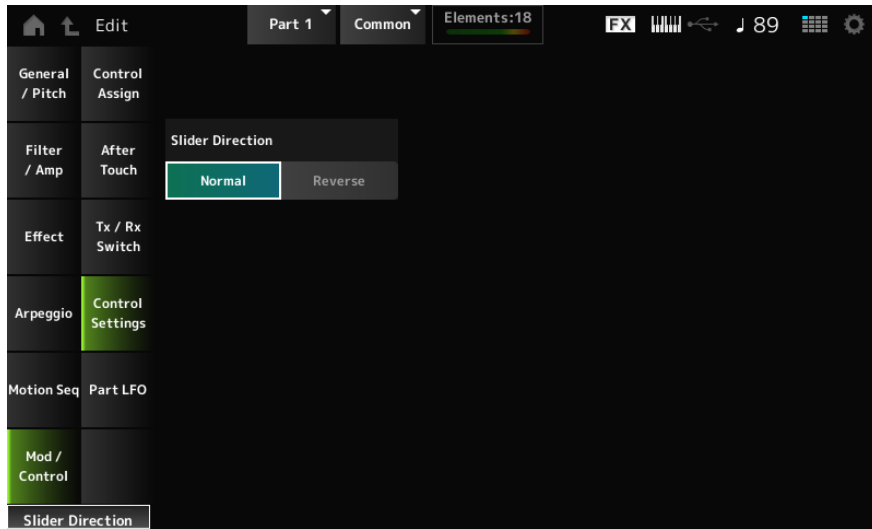

Slider Direction

Sets the direction of the Control sliders 1 to 8 for this Part when the slider Mode is set to ELEM/OP/OSC. When set to Reverse, the volume controls on the screen will change to organ sliders. The organ sliders will be shown when you select a Part and set the View Mode to Part Info. Settings: Normal (up from the bottom), Reverse (down from the top)

Part LFO

On the Part LFO screen, you can set the Part LFO.

Operation

[PERFORMANCE (HOME)] → Part Common selection → [EDIT/↺] → Mod/Control → Part LFO

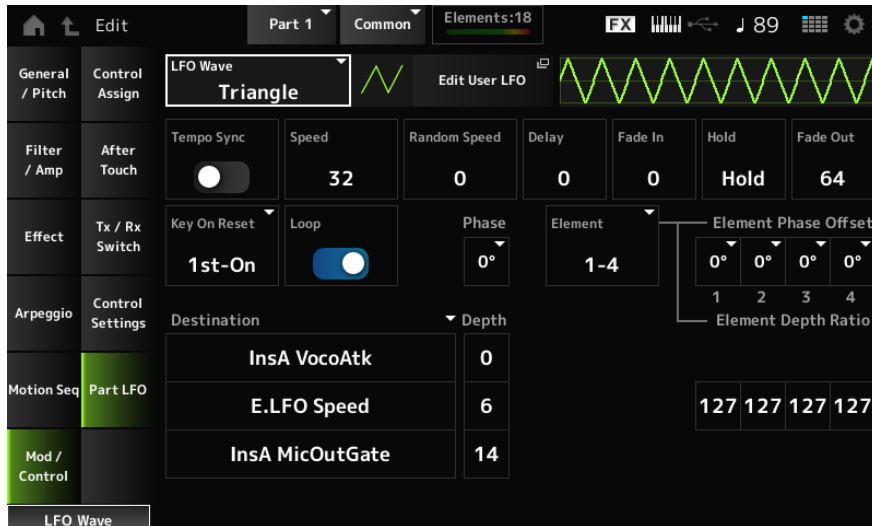

LFO Wave

Selects the LFO Wave and sets the type of cyclical changes to the LFOs.

Settings: Triangle, Triangle+, Saw Up, Saw Down, Squ1/4, Squ1/3, Square, Squ2/3, Squ3/4, Trapezoid, S/H1, S/H2, User

Edit User LFO

The User LFO Edit screen will open.

You can create an LFO waveform of up to 16 steps.

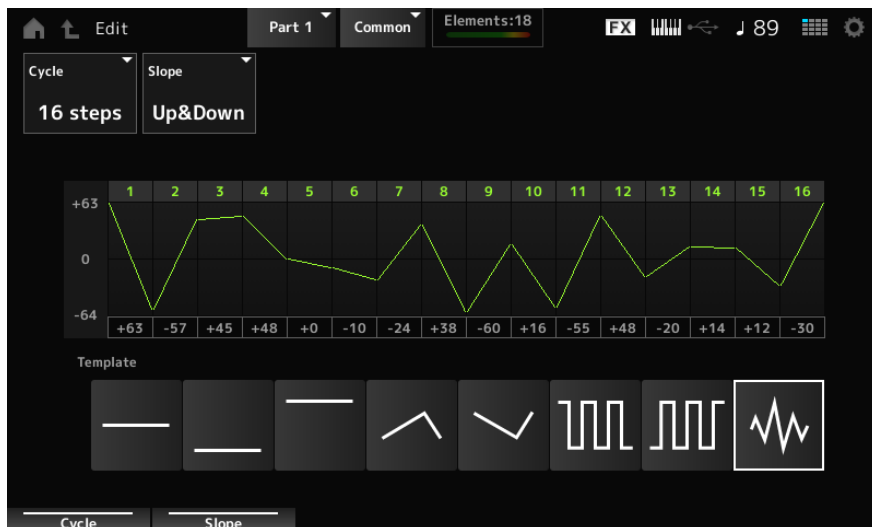

- **Cycle**

Sets the number of LFO steps.

Settings: 2 steps, 3 steps, 4 steps, 6 steps, 8 steps, 12 steps, 16 steps

- **Slope**

Sets the changes to the slope of the waveform currently shown on the screen.

Settings: Off (no slope), Up, Down, Up&Down

- **User LFO Step Value**

Sets the value for each step.

Settings: -64--+0--+63

- **Template**

Selects the template for the LFO waveform.

Tempo Sync (LFO Tempo Sync)

Sets the speed of the LFO Wave changes to synchronize to Arpeggio or Song playback.

Settings: Off (not synchronized), On (synchronized)

- **When set to Off**

Speed (LFO Speed)

Sets the speed of LFO Wave changes.

This parameter is not available when Tempo Sync (LFO Tempo Sync) is set to On.

Settings: 0-63

Random Speed (Part LFO Random Speed Depth)

Changes the LFO Speed randomly.

This parameter is not available when Tempo Sync (LFO Tempo Sync) is set to On.

Settings: 0-127

- **When set to On**

Tempo Speed (LFO Tempo Speed)

Sets the speed of LFO Wave changes by using musical note values.

Settings: 1/16 (sixteenth notes), 1/8 Tri. (eighth-note triplets), 1/16 Dot. (dotted sixteenth notes), 1/8 (eighth notes), 1/4 Tri. (quarter-note triplets), 1/8 Dot. (dotted eighth notes), 1/4 (quarter notes), 1/2 Tri. (half-note triplets), 1/4 Dot. (dotted quarter notes), 1/2 (half notes), Whole Tri. (whole-note triplets), 1/2 Dot. (dotted half notes), 1/4 × 4 (quarter-note quadruplets; four quarter notes to the beat), 1/4 × 5 (quarter-note quintuplets; five quarter notes to the beat), 1/4 × 6 (quarter-note sextuplets; six quarter notes to the beat), 1/4 × 7 (quarter-note septuplets; seven quarter notes to the beat), 1/4 × 8 (quarter-note octuplets; eight quarter notes to the beat), 1/4 × 16 (sixteen quarter-notes to the beat), 1/4 × 32 (thirty-two quarter-notes to the beat), 1/4 × 64 (sixty-four quarter-notes to the beat)

Delay (LFO Delay Time)

Sets the delay time between the moment you press a key on the keyboard and the moment the LFO comes into effect.

The larger the value, the longer the delay time for the LFO to come into effect.

Settings: 0-127

Fade In (LFO Fade In Time)

Sets the time length for the LFO effect to fade in after you have released the key and the delay time set in Delay (LFO Delay Time) has elapsed. The larger the value, the longer it takes for the LFO effect to reach the maximum.

Settings: 0–127

0: The LFO changes to the maximum value without any fade-ins.

When the value is small

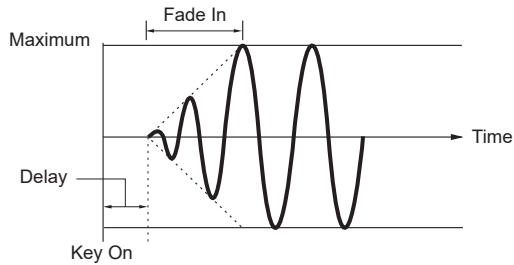

When the value is large

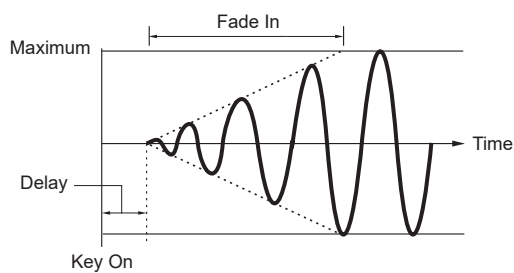

Hold (LFO Hold Time)

Sets the time for maintaining the LFO effect after the maximum level has been reached.

Settings: 0–126, Hold

Hold: Does not fade out

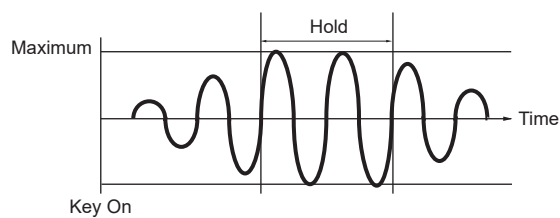

Fade Out (LFO Fade Out time)

Sets the amount of time for the LFO effect to fade out after the hold time set in Hold (LFO Hold Time) has elapsed. The larger the value, the longer it takes for the LFO effect to fade out.

Settings: 0–127

When the value is small

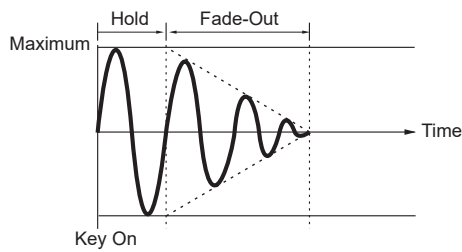

When the value is large

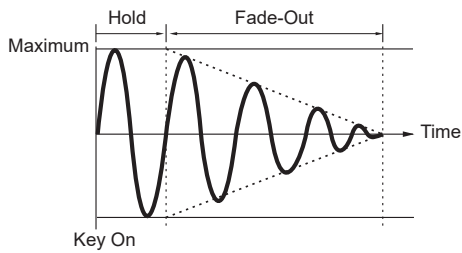

Key On Reset (LFO Key On Reset)

Resets the oscillation of the LFO when a key is pressed.

Settings: Off, Each-on, 1st-on

When set to Off

Does not reset the oscillation of the LFO. Pressing a key starts the LFO wave at whatever phase the LFO happens to be at that moment.

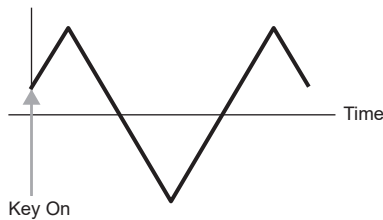

When set to Each-on

Resets the oscillation of LFO every time a key is pressed and starts the waveform at the phase specified by the Phase parameter.

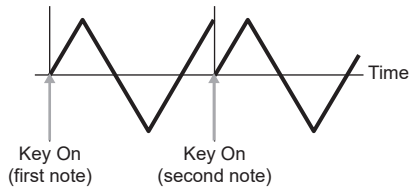

When set to 1st-on

Resets the oscillation of LFO every time a key is pressed and starts the waveform at the phase specified by the Phase parameter.

When the second note is played while the first note is held, playback will not be reset.

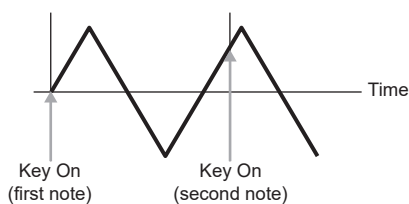

Loop (LFO Loop Switch)

Sets the LFO Wave to loop (repeat) playback or one-shot playback.

Settings: Off, On

Phase (LFO Phase)

You can set the initial phase for the time the LFO Wave is reset.

Settings: 0°, 90°, 120°, 180°, 240°, 270°

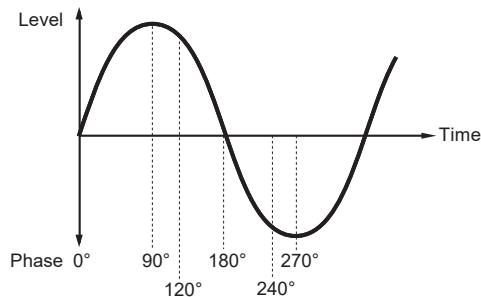

Element Phase Offset (LFO Element Phase Offset)

Sets the offset value to Phase (LFO Phase) for each Element.

Settings: 0°, 90°, 120°, 180°, 240°, 270°

Element (Display Element)

You can select a different number for the group of four elements corresponding to Element Phase Offset and Element Depth Ratio when General/Pitch → Element Settings Ex Elem Sw is On. However, the actual range of numbers you can use in the switch depends on the value set in the Element Count on the General/Pitch → Element Settings screen (Example: If the Element Count is set to 30, the Groups that can be selected are 29–32).

Settings: 1–4, 5–8, ..., 125–128

Element Phase Offset (LFO Element Phase Offset)

Sets the offset value to Phase (LFO Phase) for each Element.

You can set the initial phase for each Element when LFO Wave is reset.

When the Ex Elem Sw on the General/Pitch → Element Settings screen is set to On, you can change the element number by changing the Element (Display Element). Up to the value set in General/Pitch → Element Settings Element Count is shown.

Element Depth Ratio (LFO Element Depth Ratio)

Adjusts the Depth for each Element. Set this parameter to Off to turn off the LFO.

This parameter is shown only when the selected Destination is related to Elements.

When General/Pitch → Element Settings Ex Elem Sw is set to On, the adjusted Depth element number can be changed with Element (Display Element).

Up to the value set in General/Pitch → Element Settings Element Count is shown.

Settings: Off, 0–127

Destination (LFO Destination)

Sets the function to be controlled by the LFO Wave.

Settings: Insertion Effect A Parameter 1–24, Insertion Effect B Parameter 1–24, Level, Pitch, Cutoff, Resonance, Pan, E.LFO Speed

Depth (LFO Depth)

Sets the depth of LFO Wave control for each Destination.

Settings: 0–127

Part Edit (AWM2) Element Edit Screens

A Normal Part (AWM2) consists of up to 128 elements.

Part Edit (AWM2) includes Part Common Edit (for setting parameters for the entire Part) and Element Edit (for setting parameters for each Element in the Part).

Osc/Tune

On the Osc/Tune screen, you can set the Oscillator for the Element.

Here, you can select the Waveform used as the basis for the sound and set the key range and velocity range of the Element.

Operation

[PERFORMANCE (HOME)] → [EDIT/↶] → Part selection → Element selection → Osc/Tune

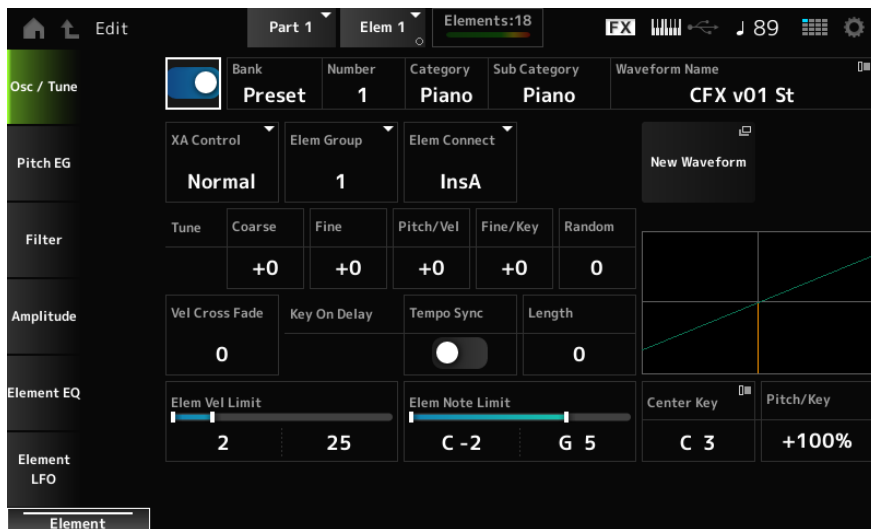

Element Switch

Sets the selected Element on or off.

Settings: Off, On

Bank (Waveform Bank)

Number (Waveform Number)

Category (Waveform Category)

Sub Category (Waveform Sub Category)

Waveform Name

Shows the name of the Waveform selected for the Element.

Bank indicates the type of Waveform (Preset, User, and Library) assigned to the Element.

Settings: Refer to the Data List

XA Control

XA (Expanded Articulation) is a function for creating realistic sounds like those on acoustic instruments as well as creating new synth sounds.

You can create such sounds by setting the XA Control to specify the way the Element is played.

Settings: Normal, Legato, Key Off, Cycle, Random, A.Sw Off, A.Sw1 On, A.Sw2 On

Normal: Played as a normal Element.

Legato: Played when Mono/Poly is set to Mono. When you play in Legato, the Element set to Legato will be played instead of the Element set to Normal

Key Off: Played when a finger is lifted off from the key

Cycle: Played when there are a series of Elements set in Cycle

Random: Plays the Elements randomly when multiple Elements are set to Random

A.Sw Off: Played when both [ASSIGN 1] and [ASSIGN 2] buttons are set to Off.

A.Sw1 On: Played when the [ASSIGN 1] button is set to On.

A.Sw2 On: Played when the [ASSIGN 2] button is set to On.

Example of XA Control setting

- Creating smooth legato

Make the Element alternate between one element with XA Control set to Normal and another element with the XA Control set to Legato.

- Creating the sound that is produced when you release a key

Create an Element with XA Control set to Key Off.

- Creating randomness for the same note

Make the Element with XA Control set to Cycle and another one with XA Control set to Random.

- Producing sounds unique to acoustic instruments, such harmonics and palm mute on the guitar, flutter-tonguing on the flute, and growl on the saxophone

Set up an Element with XA Control set to A.Sw Off, A.Sw1 On, or A.Sw2 On, and control from the [ASSIGN 1] and [ASSIGN 2] buttons on the top panel.

NOTE

The [ASSIGN 1] and [ASSIGN 2] buttons can be set to On or Off by sending the Control Change number set in Control → Control Number on the Common Edit screen from an external device.

Elem Group (Element Group Number)

This parameter is for sorting Elements having the same XA Control setting into groups.

When XA Control of all Elements is set to Normal, this setting is not effective.

Settings: 1–8

Elem Connect (Element Connection Switch)

Sets the output of the Element to Insertion Effect A or Insertion Effect B.

Setting it to Thru bypasses the Insertion Effects.

Settings: Thru, InsA, InsB

New Waveform

Loads an audio file saved to USB flash drive as a Waveform.

Edit Waveform appears when a Waveform is loaded.

Edit Waveform

The Waveform Edit screen will open.

Coarse (Coarse Tune)

Shifts the pitch of the Element in semitones.

Settings: -48+0+48

Fine (Fine Tune)

Finely adjusts the pitch of the Element.

Settings: -64+0+63

Pitch/Vel (Pitch Velocity Sensitivity)

Sets how the pitch change responds to Velocity or the strength of the keystroke.

Settings: -64+0-63

Positive value: The faster the Velocity, the higher the pitch becomes

0: kept unchanged

Negative value: The faster the Velocity, the lower the pitch becomes

Fine/Key (Fine Tune Key Follow Sensitivity)

Sets how the pitch change in the Fine Tuning responds to the position of the key.

Settings: -64+0-63

Positive value: The pitch goes down when you press a key in the bass section, and the pitch goes up when you press a key in the treble section

Negative value: The pitch goes up when you press a key in the bass section, and the pitch goes down when you press a key in the treble section

Random (Random Pitch Depth)

Changes the pitch of the Element randomly each time a key is pressed.

Set the parameter to a larger value to create more pitch changes. When the value is set to 0, the pitch is kept unchanged.

Settings: 0-127

Vel Cross Fade (Velocity Cross Fade)

Sets the output level of the Oscillator to become lower as keystroke Velocity values outside the Velocity Limit become further from the value set in Velocity Limit.

The larger the value, the more gradually the way the output level of the Oscillator decreases. When set to 0, no sound is produced if the Velocity is outside the Velocity Limit.

Settings: 0-127

When Level/Vel is set to +0

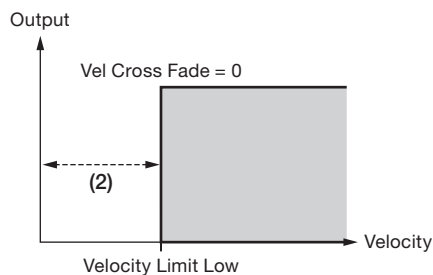
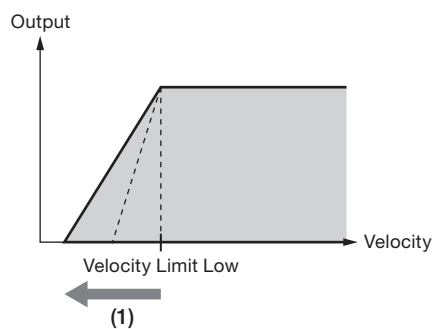

(1) When a larger value is used, the slope will be shifted to the left

(2) When set to 0, no sound is produced if the Velocity is outside the Velocity Limit

Key On Delay Tempo Sync (Key On Delay Tempo Sync Switch)

Sets the timing of the Key On Delay to synchronize with the tempo.

Settings: Off, On

Key On Delay Length (Key On Delay Time Length)

Sets the delay time from when the moment the key is pressed to when sound is produced.

This parameter is not available when Key On Delay Tempo Sync (Key On Delay Tempo Sync Switch) is set to On.

Settings: 0–127

Length (Key On Delay Note Length)

You can set the timing for Key On Delay by using musical note values.

This parameter is available when Key On Delay Tempo Sync (Key On Delay Tempo Sync Switch) is set to On.

Settings: 1/16 (sixteenth notes), 1/8 Tri. (eighth-note triplets), 1/16 Dot. (dotted sixteenth notes), 1/8 (eighth notes), 1/4 Tri. (quarter-note triplets), 1/8 Dot. (dotted eighth notes), 1/4 (quarter notes), 1/2 Tri. (half-note triplets), 1/4 Dot. (dotted quarter notes), 1/2 (half notes), Whole Tri. (whole-note triplets), 1/2 Dot. (dotted half notes), 1/4 × 4 (quarter-note quadruplets; four quarter notes to the beat), 1/4 × 5 (quarter-note quintuplets; five quarter notes to the beat), 1/4 × 6 (quarter-note sextuplets; six quarter notes to the beat), 1/4 × 7 (quarter-note septuplets; seven quarter notes to the beat), 1/4 × 8 (quarter-note octuplets; eight quarter notes to the beat)

Velocity Limit

Sets the velocity range (lowest and highest values) for playing the Element wave.

When this is set so that the higher value is first and the lower value is second (for example, 93 to 34), the Element sounds only for velocities of 1 to 34 and 93 to 127.

Settings: 1–127

Note Limit

Sets the note range (lowest and highest notes) for the Element.

When the first note specified is higher than the second (for example, C5 to C4), the Element is played in the ranges C2 to C4 and C5 to G8.

Settings: C–2–G8

Center Key (Pitch Key Follow Sensitivity Center Key)

Sets the reference key (note) for Pitch/Key (Pitch Key Follow Sensitivity).

The key set with the note number here is played at the normal pitch regardless of the Pitch/Key setting.

Settings: C–2–G8

Pitch/Key (Pitch Key Follow Sensitivity)

Sets the difference in pitch between two adjacent keys. The reference note is specified by Center Key (Pitch Key Follow Sensitivity Center Key).

This parameter is useful for playing unpitched sounds, such as special effects, or for playing a percussion instrument as a Normal Part, or for any other cases where the pitch difference does not have to be in semitones.

Settings: -200%—+0%—+200%

+100% (normal setting): Pitch difference between the two keys next to each other is set to a semitone

0%: No pitch difference between the two keys, and all keys are played at the pitch set in Center Key

Negative value: Sets an opposite pitch response such that lower notes result in higher pitch, and higher notes result in lower pitch.

Pitch/Key and Center Key

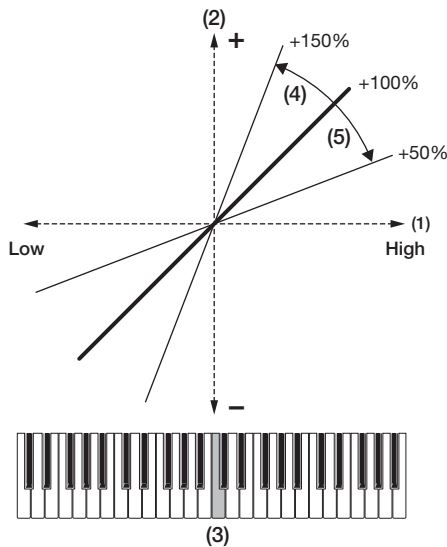

(1) Key

(2) Amount of change in pitch

(3) Center Key

(4) The pitch difference between adjacent keys becomes larger

(5) The pitch difference between adjacent keys becomes smaller

Waveform Edit

Opens the Waveform Edit screen.

Here, you can set the various Key Banks that make up a Waveform.

■ Key Banks

A Key Bank is digital data comprised of a short audio segment, such as vocals or other sounds, loaded into the instrument. It has the same characteristics as a .wav file; however, to avoid confusion a different name is used to distinguish it from the Waveform.

■ Key Banks and Waveforms

Key Banks are always saved as a part of a Waveform.

A Waveform can contain multiple Key Banks, allowing you to save dozens of Key Banks in a single Waveform.

However, if all of the Key Banks sound simultaneously, it would become unmanageable, so you can set the range of keys (Note Limit) and velocity range (Velocity Limit) that will sound for each Key Bank. By setting up multiple Key Banks, you can play various Key Bank sounds depending on the section of the keyboard you use and the strength of your keystroke.

Example of Key Bank and Waveform setup

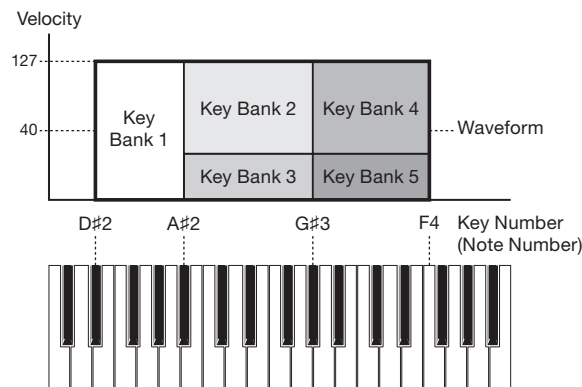

■ Parts and waveforms

Waveforms can be incorporated into Parts and played on the keyboard.

You can assign one waveform per element to a part using Part Edit (AWM2), Element Edit, Drum Part Edit (AWM2) and Key Edit.

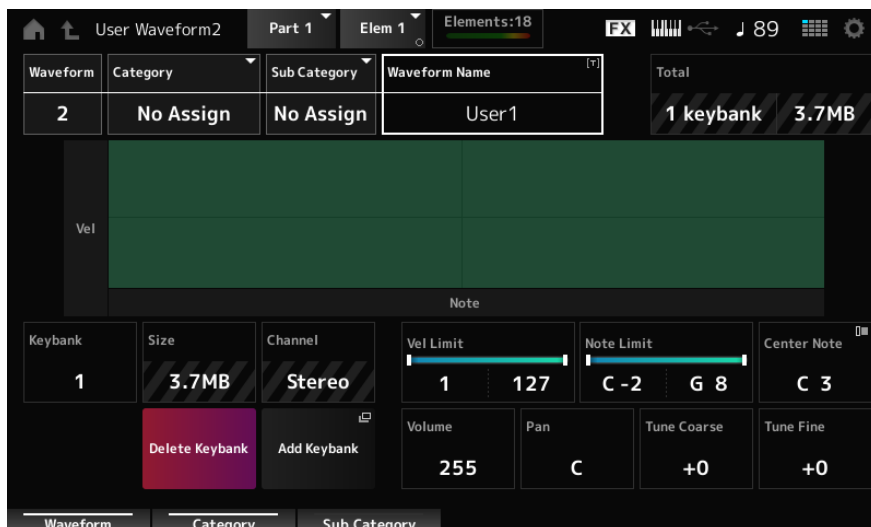

Waveform

Shows the name of the selected Waveform.

Category (Waveform Category)**Sub Category (Waveform Sub Category)**

Sets the Main category and Sub category of the selected Waveform.

Settings: Refer to the Data List

Name (Waveform Name)

You can save the Waveform you are editing under a new name, You can use up to 20 alphanumeric characters.

Total

Shows the number of Key Banks in the waveform and the total size of the data capacity.

Keybank (Keybank Number)

Shows the Key Bank number.

Size (Keybank Size)

Shows the total size of data capacity.

Channel (Keybank Channel)

Shows whether the Key Bank is stereo or mono.

Velocity Limit

Sets the velocity range (lowest and highest values) for playing the Key Bank.

Settings: 1–127

Note Limit

Sets the note range (lowest and highest notes) for playing the Key Bank.

Settings: 1–127

Center Note

Sets the key (pitch) of the original waveform data.

Settings: C–2–G8

Volume

Sets the volume of the Key Bank.

Settings: 0–255

Pan

Sets the Pan position (in the stereo field) of the Key Bank.

Settings: L63–C (center)–R63

Tune Coarse (Coarse Tune)

Shifts the pitch of the Key Bank in semitones.

Settings: –64–+63

Tune Fine (Fine Tune)

For fine pitch adjustment of the Key Bank.

Settings: –64–+63

Delete Keybank

Deletes the Key Bank.

Add Keybank

Adds a Key Bank to the waveform.

Pitch EG

The Pitch EG screen lets you set the Envelope Generator for the Oscillator.

By setting the PEG (Pitch Envelope Generator) time and level (the amount of pitch change), you can set how the sound changes from the moment you press a key on the keyboard to when the sound decays to silence.

Operation

[PERFORMANCE (HOME)] → [EDIT/↺] → Part selection → Element selection → Pitch EG

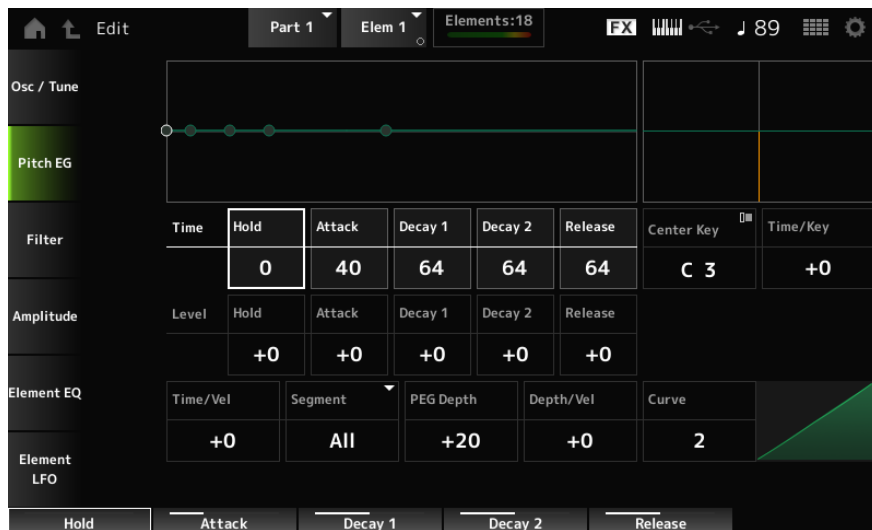

Hold Time (PEG Hold Time)

Sets the length of time it takes for keeping the pitch at Hold Level (PEG Hold Level) starting from the moment you press a key on the keyboard.

Settings: 0–127

Attack Time (PEG Attack Time)

Sets the length of time it takes for the pitch to change from the end of the Hold Time (PEG Hold Time) to the Attack Level (PEG Attack Level).

Settings: 0–127

Decay1 Time (PEG Decay 1 Time)

Sets the length of time it takes for the pitch to change from the Attack Level (PEG Attack Level) to the Decay1 Level (PEG Decay 1 Level).

Settings: 0–127

Decay2 Time (PEG Decay 2 Time)

Sets the length of time it takes for the pitch to change from the Decay1 Level (PEG Decay 1 Level) to the Decay2 Level (PEG Decay 2 Level).

Settings: 0–127

Release Time (PEG Release Time)

Sets the length of time it takes for the pitch to change from the moment you have released the key until it reaches the Release Level (PEG Release Level).

Settings: 0–127

Hold Level (PEG Hold Level)

Sets the pitch for the moment you press the key.

Settings: -128→0→+127

Attack Level (PEG Attack Level)

Sets the change in pitch from the Hold Level or the moment you press a key.

Settings: -128→0→+127

Decay1 Level (PEG Decay 1 Level)

Sets the next pitch value to change from the Attack Level (PEG Attack Level).

Settings: -128→0→+127

Decay2 Level (PEG Decay 2 Level)

Sets the next pitch value to change from the Decay1 Level (PEG Decay 1 Level).

Settings: -128→0→+127

Release Level (PEG Release Level)

Sets the final pitch to reach after you have released the key.

Settings: -128→0→+127

Center Key (PEG Time Key Follow Sensitivity Center Key)

Sets the reference key (note) for Time/Key (PEG Time Key Follow Sensitivity).

With the note (key) set here, the resulting sound of the pitch change set in PEG is played.

Settings: C-2-G8

Time/Key (PEG Time Key Follow Sensitivity)

Sets how the speed of the pitch change in PEG responds to key position.

The change speed in PEG is used for the specified key in Center Key (PEG Time Key Follow Sensitivity Center Key).

Settings: -64→+0→+63

Positive value: The lower the key played, the slower the change in the PEG; the higher the key played, the faster the change in the PEG.

0: No PEG changes regardless of the key position

Negative value: The higher the key pressed, the slower the pitch changes of the PEG.

Center Key and Time/key

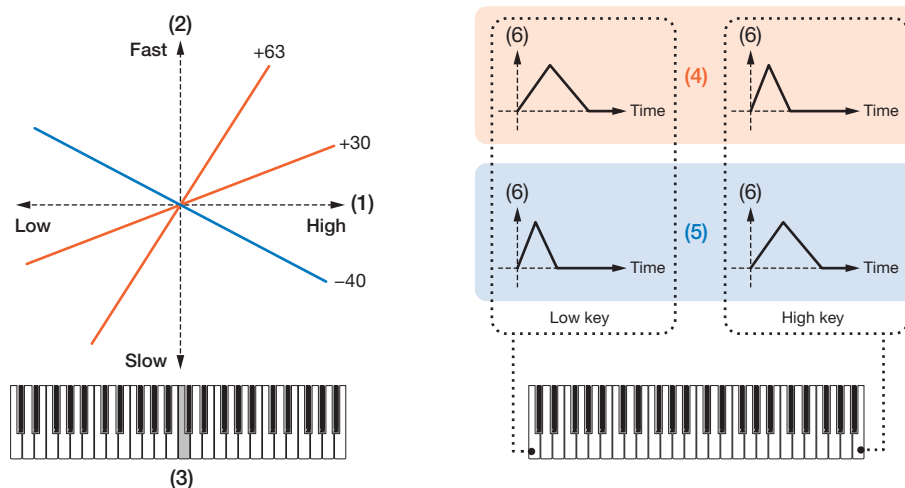

- (1) Key
- (2) The speed of the pitch change in PEG
- (3) Center Key
- (4) When Time/Key is positive
- (5) When Time/Key is negative
- (6) Pitch

Time/Vel (PEG Time Velocity Sensitivity)

Segment (PEG Time Velocity Sensitivity Segment)

Sets how the time of the pitch change in PEG responds to Velocity or the strength of the keystroke.

First, set the time value in Segment, and then the velocity sensitivity value in Time/Vel.

Settings: Time/Vel: -64--+0--+63

Positive value: The faster the Velocity, the faster the pitch changes in the PEG

0: No PEG changes regardless of the velocity setting.

Negative value: The faster the Velocity, the slower the pitch changes in the PEG

When the value is positive

Fast Velocity (pitch change is fast)

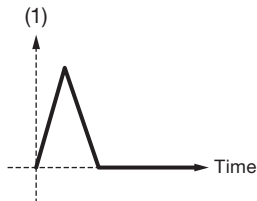

(1) Pitch

Slow Velocity (pitch change is slow)

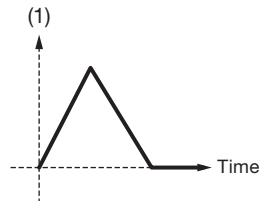

Settings: Segment: Attack, Atk+Dcy, Decay, Atk+Rls, All

Attack: The Time/Vel value affects the Attack Time

Atk+Dcy: The Time/Vel value affects the Attack Time and Decay1Time

Decay: The Time/Vel value affects the Decay Time

Atk+Rls: The Time/Vel value affects the Attack Time and Release Time

All: The Time/Vel value affects the time-related settings in PEG

PEG Depth

Sets the amount of pitch change controlled by the PEG. The further the depth is from the value 0, the wider the pitch change range becomes.

Settings: -64--+0--+63

0: kept unchanged

Negative value: Pitch change is inverted.

Depth/Vel (PEG Depth Velocity Sensitivity)

Curve (PEG Depth Velocity Sensitivity Curve)

Sets how the depth range of the pitch change controlled by the PEG responds to Velocity or the strength of the keystroke.

Also, with the Curve setting, you can set how the PEG Depth responds to the Velocity. The vertical axis represents velocity while the horizontal axis represents the depth range of the pitch change.

Settings: Depth/Vel: -64--+0--+63

Positive value: Faster Velocity values widen the depth range of the pitch change controlled by the PEG, while slower values narrow the depth range

0: No PEG changes regardless of the velocity setting.

Negative value: Faster Velocity values narrow the depth range of the pitch change controlled by the PEG, while slower values widen the depth range

When the value is positive

Fast Velocity (the depth range in pitch change is wider)

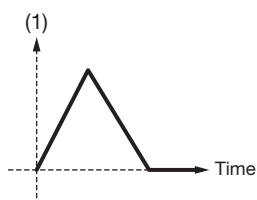

(1) Pitch Depth

Slow Velocity (the depth range in pitch change is narrower)

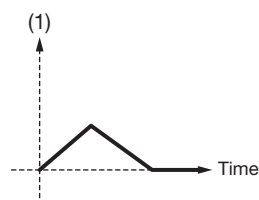

Settings: Curve: 0-4

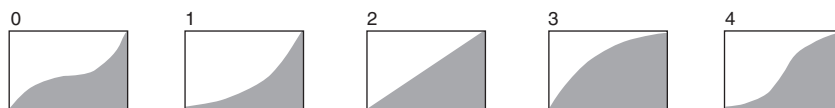

Type

On the Type screen, you can select a filter type for the Element. The available parameters differ depending on the filter type you have selected here.

Operation

[PERFORMANCE (HOME)] → [EDIT/↶] → Part selection → Element selection → Filter → Type



Filter Type

Sets the filter for the Element. The filters available on this instrument are grouped into four types: LPF, HPF, BPF, and BEF. Settings: LPF24D, LPF24A, LPF18, LPF18s, LPF12+HPF12, LPF6+HPF12, HPF24D, HPF12, BPF12D, BPFw, BPF6, BEF12, BEF6, DualLPF, DualHPF, DualBPF, DualBEF, LPF12+BPF6, Thru

- **LPF (Low Pass Filter)**

Cuts the signals above the value set in Cutoff Frequency. This is very popular and useful for producing classic synthesizer sounds. The sound becomes brighter as you raise the Cutoff Frequency, since more signals are passed by the filter. The sound becomes darker as you lower the Cutoff Frequency, since signals are cut or blocked by the filter.

You can produce a distinctive “peaky” sound by raising the Resonance or boosting the signal level near the Cutoff Frequency.

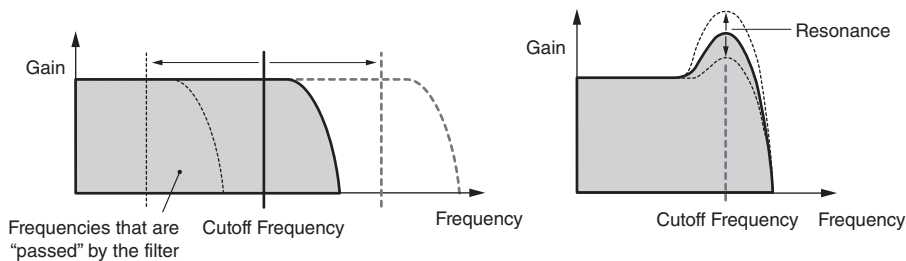

LPF24D: A dynamic 4-pole (–24dB/oct) LPF with a characteristic digital sound. Compared to the LPF24A type, this filter can produce a more pronounced Resonance effect

LPF24A: A digital dynamic LPF with characteristics similar to a 4-pole (–24dB/oct) analog synthesizer filter

LPF18: 3-pole (–18dB/oct) LPF

LPF18s: 3-pole (–18dB/oct) LPF. The frequency curve is gentler than the LPF18

- **HPF (High Pass Filter)**

A Filter Type that only passes signals above the Cutoff Frequency.

You can produce a distinctive “peaky” sound by raising the Resonance or boosting the signal level near the Cutoff Frequency.

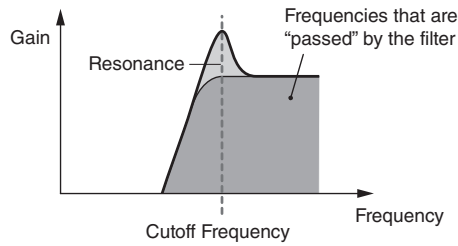

LPF12+HPF12: A combination of a 2-pole (–12dB/oct) LPF and HPF connected in serial. When this Filter Type is selected, HPF Cutoff (HPF Cutoff Frequency) and HPF Cutoff /Key (HPF Cutoff Key Follow Sensitivity) can be set

LPF6+HPF12: A combination of a –6dB/oct LPF and a –12dB/oct connected in serial. When this Filter Type is selected, HPF Cutoff (HPF Cutoff Frequency) and HPF Cutoff /Key (HPF Cutoff Key Follow Sensitivity) can be set

HPF24D: A dynamic –24dB/oct HPF with a characteristic digital sound. This filter can produce a pronounced Resonance effect.

HPF12: A dynamic –12dB/oct HPF

- **BPF (Band Pass Filter)**

A Filter Type that only passes signals for a set Cutoff Frequency band and cuts all other signals.

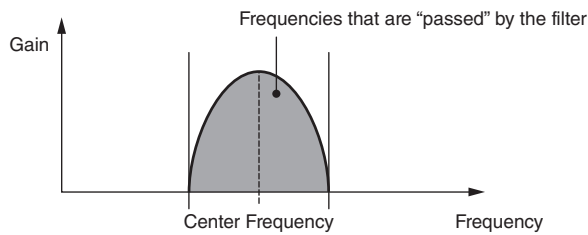

BPF12D: The combination of a –12dB/oct HPF and LPF with a characteristic digital sound

BPFw: The combination of a –12dB/oct HPF and LPF. Allow wider bandwidth settings

BPF6: The combination of a –6dB/oct HPF and LPF

BPF12D

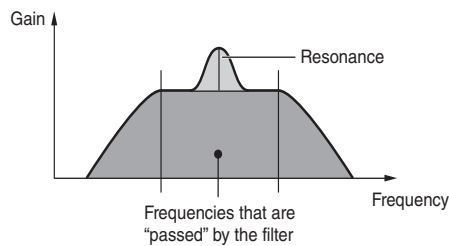

BPFw

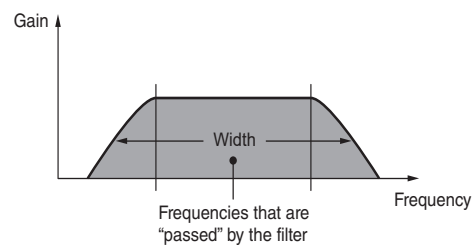

BPF6

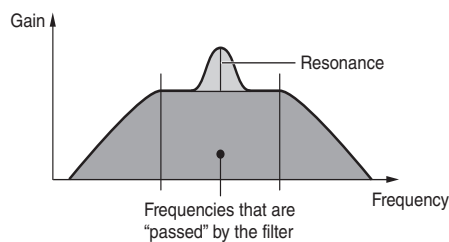

- **BEF (Band Eliminate Filter)**

Has an opposite effect on the sound compared to the BPF (Band Pass Filter). A Filter Type that cuts off signals near the set Cutoff Frequency and passes signals in other frequency bands.

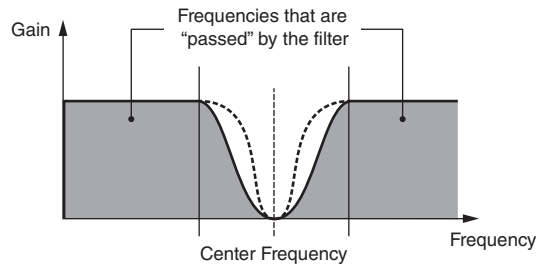

BEF12: -12dB/oct BEF

BEF6: -6dB/oct BEF

DualLPF: Two -12dB/oct LPF connected in parallel. Sets the distance between the Cutoff Frequencies for the two filters with Distance. The lower limit frequency is set on the screen, and the upper limit frequency is automatically determined in conjunction

DualHPF: Two -12dB/oct HPF connected in parallel

DualBPF: Two -6dB/oct BPF connected in parallel

DualBEF: Two -6dB/oct BEF connected in serial

LPF12+BPF6: A combination of a -12dB/oct LPF and -6dB/oct BPF connected in parallel. Sets the distance between the Cutoff Frequencies for the two filters with Distance. The lower limit frequency is set on the screen, and the upper limit frequency is automatically determined in conjunction

DualLPF

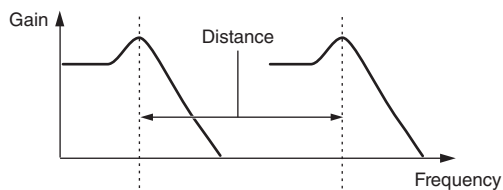

DualBEF

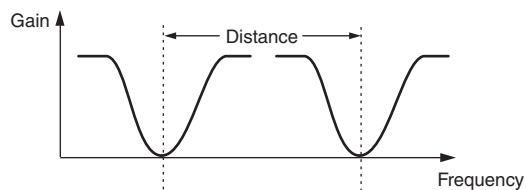

LPF12+BPF6

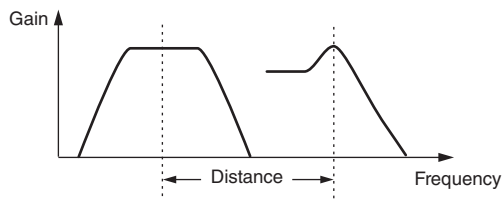

Cutoff (Filter Cutoff Frequency)

Sets the cutoff frequency.

The frequency set here is used by the filter set in Type.

Settings: 0-1023

Cutoff/Vel (Filter Cutoff Velocity Sensitivity)

Sets how Cutoff Frequency responds to Velocity or the strength of the keystroke.

Settings: -64-+0-+63

Positive value: The faster the Velocity, the higher the Cutoff Frequency value

0: Cutoff frequency does not respond to the Velocity.

Negative value: The slower the Velocity, the higher the Cutoff Frequency value

Resonance (Filter Resonance)

Width (Filter Width)

The parameter shown here varies depending on the Filter Type setting. Resonance is shown for LPF, HPF, BPF (excluding BPFw), or BEF, and Width is shown for BPFw.

For Resonance, this parameter indicates the strength of resonance. This can be used in combination with the Cutoff parameter to add further character to the sound.

For the BPFw, Width is used for adjusting the width of the frequencies passed by the filter.

Settings: 0–127

Res/Vel (Filter Resonance Velocity Sensitivity)

Sets how the resonance level responds to Velocity or the strength of the keystroke.

This parameter may not be available depending on the Filter Type.

Settings: –64–+0–+63

Positive value: The higher the Velocity, the greater the Resonance becomes

0: Resonance value does not change in response to Velocity.

Negative value: The lower the Velocity, the greater the Resonance becomes

Cutoff/Key (Filter Cutoff Key Follow Sensitivity)

Sets how the cutoff frequency level of the filter responds to the key position.

The reference point is the Cutoff Frequency for the key set in Center Key (FEG Time Key Follow Sensitivity Center Key).

Settings: –200%–0%–+200%

Positive value: The lower the key played, the lower the Cutoff Frequency becomes; the higher the key played, the higher the Cutoff Frequency becomes

Negative value: The lower the key played, the higher the Cutoff Frequency becomes; the higher the key played, the lower the Cutoff Frequency becomes

Distance

Sets the distance between the Cutoff Frequencies for the Dual Filter types and the LPF12+BPF6 filter.

This parameter may not be available depending on the Filter Type.

Settings: –128–+0–+127

HPF Cutoff (HPF Cutoff Frequency)

Sets the center frequency for the functions that control the filter cutoff and how fast the FEG changes according to the key follow setting of the HPF.

Increasing the value results in a higher Cutoff Frequency, and the low frequency signals are cut or blocked to make the sound brighter. Decreasing the value results in a lower Cutoff Frequency, allowing more bass components to pass through to make the sound richer and deeper.

This parameter is not available when the Filter Type is set to LPF12+HPF12 or LPF6+HPF12.

Settings: 0–1023

HPF Cutoff/Key (HPF Cutoff Key Follow Sensitivity)

Sets the level of the Cutoff Frequency of the HPF according to the position of the key.

This parameter is not available when the Filter Type is set to LPF12+HPF12 or LPF6+HPF12.

Settings: –200%–+0–+200%

Positive value: The lower the key played, the lower the Cutoff Frequency becomes; the higher the key played, the higher the Cutoff Frequency becomes

Negative value: The lower the key played, the higher the Cutoff Frequency becomes; the higher the key played, the lower the Cutoff Frequency becomes

Gain (Filter Gain)

Sets the Gain (signals sent to the Filter unit).

Lowering the value decreases the volume of the Element.

Settings: 0–255

Filter EG

On the Filter EG screen, you can set the Filter Envelope Generator (FEG) for the Element. The FEG lets you set the degree (or level) of changes to the Cutoff Frequency and how those changes evolve over time, starting from the moment you press a key on the keyboard to the moment the sound decays.

Operation

[PERFORMANCE (HOME)] → [EDIT/↺] → Part selection → Element selection → Filter → Filter EG

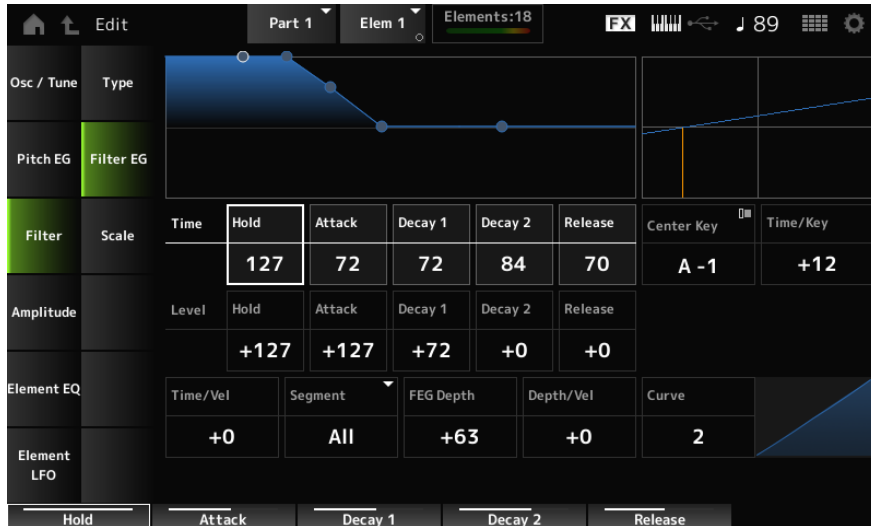

Hold Time (FEG Hold Time)

Sets the length of time it takes for maintaining the Cutoff Frequency at Hold Level (FEG Hold Level) starting from the moment you press a key on the keyboard.

Settings: 0–127

Attack Time (FEG Attack Time)

Sets the length of time it takes for the Cutoff Frequency to change from the end of Hold Time (FEG Hold Time) to the Attack Level (FEG Attack Level).

Settings: 0–127

Decay 1 Time (FEG Decay 1 Time)

Sets the length of time it takes for the Cutoff Frequency to change from the Attack Level (FEG Attack Level) to the Decay 1 Level (FEG Decay 1 Level).

Settings: 0–127

Decay 2 Time (FEG Decay 2 Time)

Sets the length of time it takes for the Cutoff Frequency to change from the Decay 1 Level (FEG Decay 1 Level) to the Decay 2 Level (FEG Decay 2 Level).

Settings: 0–127

Release Time (FEG Release Time)

Sets the length of time it takes for the Cutoff Frequency to change from the moment you release your finger from the key until it reaches the Release Level (FEG Release Level).

Settings: 0–127

Hold Level (FEG Hold Level)

Sets the Cutoff Frequency at the moment you press the key.

Settings: -128→+0→+127

Attack Level (FEG Attack Level)

Sets the Cutoff Frequency value to change after you press the key.

Settings: -128→+0→+127

Decay 1 Level (FEG Decay 1 Level)

Sets the next Cutoff Frequency value to change from the Attack Level (FEG Attack Level).

Settings: -128→+0→+127

Decay 2 Level (FEG Decay 2 Level)

Sets the Cutoff Frequency that is maintained while the key is held down.

Settings: -128→+0→+127

Release Level (FEG Release Level)

Sets the next Cutoff Frequency value after you release your finger from the key.

Settings: -128→+0→+127

Center Key (FEG Time Key Follow Sensitivity Center Key)

Sets the reference key (note) for Time/Key.

With the key (note) set here, the speed of change in the cutoff frequency set in FEG is used as is.

Settings: C-2-G8

Time/Key (FEG Time Key Follow Sensitivity)

Sets the degree to which the speed of change in the cutoff frequency caused by FEG increases or decreases depending on the pitch of the key.

The change speed in FEG is used for the specified key in Center Key.

Settings: -64→+63

Positive value: The lower the key played, the slower the change in Cutoff Frequency controlled by the FEG becomes; the higher the key played, the faster the change becomes

0: No changes to the FEG regardless of the key position

Negative value: The lower the key played, the faster the change in Cutoff Frequency controlled by the FEG becomes; the higher the key played, the slower the change becomes

Center Key and Time/key

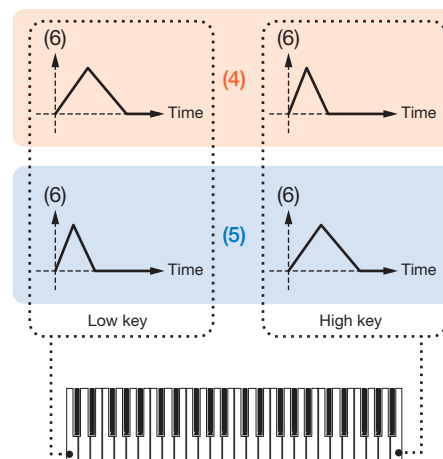
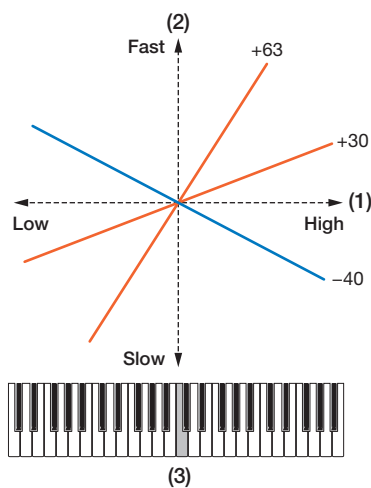

- (1) Key
- (2) Speed of the Cutoff Frequency by the FEG
- (3) Center Key
- (4) When Time/Key is positive
- (5) When Time/Key is negative
- (6) Cutoff Frequency

Time/Vel (FEG Time Velocity Sensitivity) Segment (FEG Time Velocity Sensitivity Segment)

Sets how the Cutoff Frequency responds to Velocity or the strength of the keystroke.

First, set the time value in Segment, and then the velocity sensitivity value in Time/Vel.

Settings: Time/Vel: -64→0→+63

Positive value: The faster the Velocity, the faster the change in the Cutoff Velocity by the FEG; the slower the Velocity, the slower the change

0: No changes regardless of the Velocity setting.

Negative value: The faster the Velocity, the slower the change in the Cutoff Velocity by the FEG; the slower the Velocity, the faster the change

When the value is positive

Fast Velocity (fast change in Cutoff Frequency)

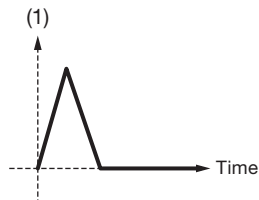

Slow Velocity (slow change in Cutoff Frequency)

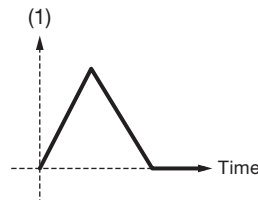

(1) Cutoff Frequency

Settings: Segment: Attack, Atk+Dcy, Decay, Atk+Rls, All

Attack: The Time/Vel value affects the Attack Time

Atk+Dcy: The Time/Vel value affects the Attack Time and Decay1Time

Decay: The Time/Vel value affects the Decay Time

Atk+Rls: The Time/Vel value affects the Attack Time and Release Time

All: The Time/Vel value affects the time-related settings in FEG

FEG Depth

Sets the depth range for the cutoff frequency change controlled by the FEG. The depth range of the Cutoff Frequency change becomes wider the further the setting is from a value of 0.

Settings: -64→0→+63

0: No changes for the Cutoff Frequency by the FEG

Negative value: Cutoff frequency changes are reversed.

Depth/Vel (FEG Depth Velocity Sensitivity)

Curve (FEG Depth Velocity Sensitivity Curve)

Depth/Vel (FEG Depth Velocity Sensitivity) sets how the depth range of the Cutoff Frequency change controlled by the FEG responds to Velocity or the strength of the keystroke.

With the Curve (FEG Depth Velocity Sensitivity Curve) setting, you can set how the FEG Depth responds to the Velocity. The vertical axis represents the velocity while the horizontal axis represents the depth range of the Cutoff Frequency change.

Settings: Depth/Vel: -64→0→+63

Positive value: The faster the Velocity, the wider the depth range in Cutoff Frequency change by the FEG; the slower the Velocity, the narrower the depth range

0: Cutoff frequency does not respond to the Velocity.

Negative value: The faster the Velocity, the narrower the depth range in Cutoff Frequency change by the FEG; the slower the Velocity, the wider the depth range

When the value is positive

Fast Velocity (the depth range in Cutoff Frequency change is wider)

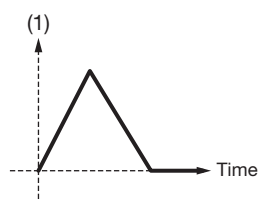

Slow Velocity (the depth range in Cutoff Frequency change is narrower)

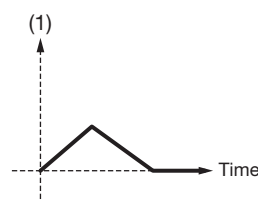

(1) Depth range in Cutoff Frequency change

Settings: Curve: 0-4

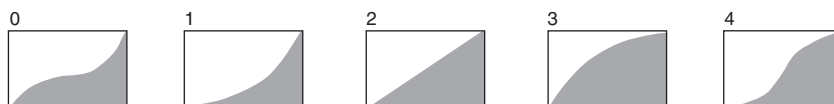

Scale

On the Scale screen, you can set the filter scale for the Element.

The Filter Scale function allows you to change the Cutoff Frequency of the filter depending on the pitch.

Operation

[PERFORMANCE (HOME)] → [EDIT/↺] → Part selection → Element selection → Filter → Scale



Break Point (Filter Cutoff Scaling Break Point) 1–4

Sets the note numbers of four points to be set to Cutoff Offset.

Settings: C–2–G8

NOTE

The note numbers for Break Point 1 to 4 will be automatically arranged in ascending order.

Cutoff Offset (Filter Cutoff Scaling Offset) 1–4

Sets the value that increases or decreases the Cutoff on Break Point (Filter Cutoff Scaling Break Point) 1–4.

Settings: –128→+0→+127

NOTE

- When the offset value is set above or below the Cutoff value, the Cutoff Frequency never goes beyond the settings.
- For any notes below Break Point 1, the value will be set to the Cutoff Frequency of 1. For any notes above Break Point 4, the value will be set to the Cutoff Frequency of 4.

Amplitude

Level/Pan

On the Level/Pan screen, you can set Level and Pan (position in the stereo field) for each Element.

Operation

[PERFORMANCE (HOME)] → [EDIT/EDIT] → Part selection → Element selection → Amplitude → Level/Pan

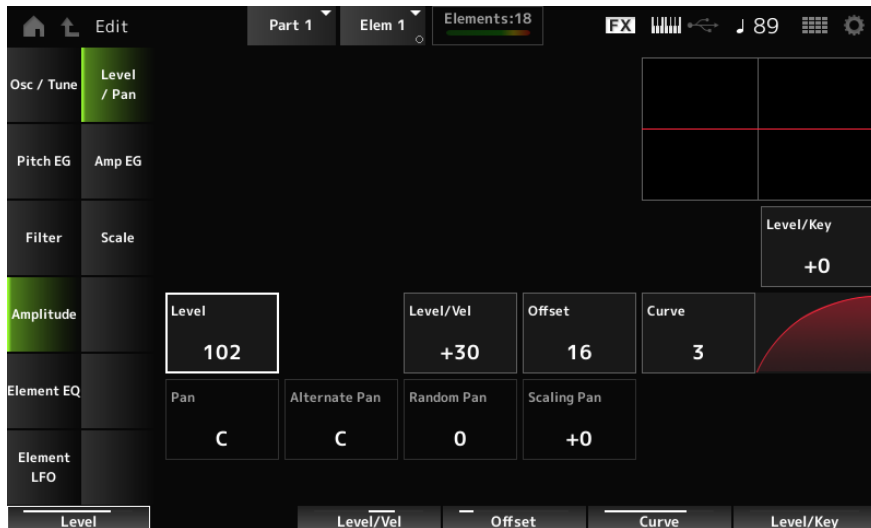

Level/Key (Level Key Follow Sensitivity)

Sets how the volume of each Element responds to key position.

The reference point is the volume specified in Center Key (AEG Time Key Follow Center Key).

Settings: -64→+0→+63

Positive value: The lower the key played, the softer the volume becomes; the higher the played, the louder the volume becomes.

Negative value: The lower the key played, the louder the volume becomes; the higher the played, the softer the volume becomes.

Level (Element Level)

Sets the output level (volume) for each Element.

Settings: 0–127

Level/Vel (Level Velocity Sensitivity)

Offset (Level Velocity Offset)

Curve (Level Sensitivity Key Curve)

Level/Vel (Level Velocity Sensitivity) sets how the volume of each Element responds to Velocity or the strength of the keystroke.

Offset (Level Velocity Offset) adjusts all settings specified in Level/Vel. When the value exceeds 127, the velocity is set to 127.

With the Curve (Level Sensitivity Key Curve) setting, you can set how the volume responds to the Velocity. The vertical axis represents the velocity while the horizontal axis represents the range for the volume changes.

Settings: Level/Vel: -64+0+63

Positive value: The faster the Velocity, the louder the volume becomes

Negative value: The slower the Velocity, the louder the volume becomes

0: No change regardless of the velocity setting.

Settings: Offset: 0-127



A: Level/Vel = 0

B: Level/Vel = 32

C: Level/Vel = 64

X: Velocity with which you play a note

Y: Velocity value sent to the internal tone generator

Settings: Curve: 0-4

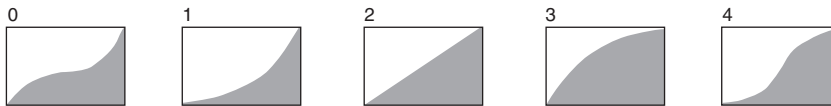

Pan (Element Pan)

Sets the Pan position (in the stereo field) for the Element.

When there are right and left Pan settings for the Elements within a Part, it may be difficult to hear the result of the Pan setting.

Settings: L63-C (center)-R63

Alternate Pan (Alternate Pan Depth)

Sets how the sound is panned alternately left and right for each key played.

The value set in Pan (Element Pan) is the center position for the right and left movement of the Pan.

Settings: L63–C (Center)–R63

Random Pan (Random Pan Depth)

Sets how the sound is panned randomly left and right for each key played.

The value set in Pan (Element Pan) is the center position in the stereo field.

Settings: 0–127

Scaling Pan (Scaling Pan Depth)

Sets how the position of the key you press affects the position of the Pan setting.

The value set in Pan (Element Pan) is the position for C3.

Settings: –64–+0–+63

Positive value: Pan position is scaled to the left for lower keys and to the right for higher keys.

Negative value: Pan position is scaled to the right for lower keys and to the left for higher keys.

Amp EG

On the Amp EG screen, you can set the AEG (Amplitude Envelope Generator) for the Element. By setting the Amp EG, you can set how the volume changes from the moment you press a key on the keyboard to when the sound decays.

Operation

[PERFORMANCE (HOME)] → [EDIT/↺] → Part selection → Element selection → Amplitude → Amp EG



Attack Time (AEG Attack Time)

Sets the length of time it takes for the volume to change from the moment you press a key on the keyboard until the time the volume reaches the value set at the Attack Level (AEG Attack Level).

Settings: 0–127

Decay 1 Time (AEG Decay 1 Time)

Sets the length of time it takes for the volume to change from the Attack Level (AEG Attack Level) to the Decay 1 Level (AEG Decay 1 Level).

Settings: 0–127

Decay 2 Time (AEG Decay 2 Time)

Sets the length of time it takes for the volume to change from the Decay 1 Level (AEG Decay 1 Level) to the Decay 2 Level (AEG Decay 2 Level).

Settings: 0–127

Release Time (AEG Release Time)

Sets the length of time it takes for the sound to decay after you have released the key.

Settings: 0–127

Initial Level (AEG Initial Level)

Sets the volume for the moment you press the key.

Settings: 0–127

Attack Level (AEG Attack Level)

Sets the volume for changing after you have pressed a key.

Settings: 0–127

Decay 1 Level (AEG Decay 1 Level)

Sets the next volume value to change from the Attack Level (AEG Attack Level).

Settings: 0–127

Decay 2 Level (AEG Decay 2 Level)

Sets the volume that is maintained while the key is held down.

Settings: 0–127

Center Key (AEG Time Key Follow Center Key)

Sets the reference key (note) for Time/Key (AEG Time Key Follow Sensitivity).

With the note (key) set here, the resulting sound of the pitch change set in Time/Key (AEG Time Key Follow Sensitivity) is played.

Settings: C–2–G8

Time/Key (AEG Time Key Follow Sensitivity)

Sets how the speed of the volume changes in AEG responds to key position.

The change speed in AEG is used for the specified key in Center Key (AEG Time Key Follow Center Key).

Settings: –64–+0–+63

Positive value: The lower the key played, the slower the AEG volume changes; the higher the key played, the faster the AEG volume changes.

0: No AEG volume change regardless of the key position

Negative value: The lower the key played, the faster the AEG volume changes; the higher the key played, the slower the AEG volume changes.

Center Key and Time/key

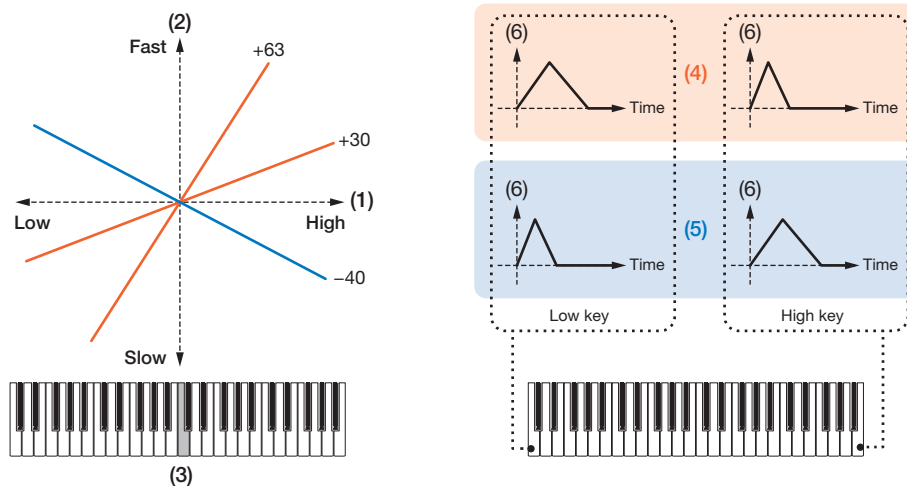

- (1) Key
- (2) Speed of volume change in AEG
- (3) Center Key
- (4) When Time/Key is positive
- (5) When Time/Key is negative
- (6) AEG volume

Release Adj (AEG Time Key Follow Sensitivity Release Adjustment)

Adjusts the sensitivity of the Time/Key (AEG Time Key Follow Sensitivity) to AEG Release.

The lower the value, the lesser the sensitivity.

Settings: 0–127

127: Same Time/Key as Decay 1 and Decay 2

0: The Time/Key does not affect the AEG Release

Time/Vel (AEG Time Velocity Sensitivity)

Segment (AEG Time Velocity Segment)

Sets the length of time it takes for volume changes in AEG to respond to Velocity or the strength of the keystroke.

First, set the time value in Segment, and then the velocity sensitivity value in Time/Vel.

Settings: Time/Vel: -64→+0→+63

Positive value: The faster the velocity, the faster the AEG volume changes.

0: No changes regardless of the Velocity setting.

Negative value: Fast velocity values result in slower AEG volume changes, while slow velocity values result in faster AEG volume changes.

When the value is positive

Fast velocity (fast volume change)

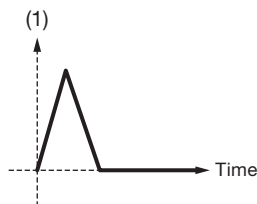

(1) Volume

Slow velocity (slow volume change)

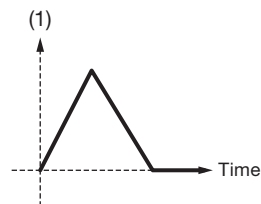

Settings: Segment: Attack, Atk+Dcy, Decay, Atk+Rls, All

Attack: The Time/Vel value affects the Attack Time

Atk+Dcy: The Time/Vel value affects the Attack Time and Decay1Time

Decay: The Time/Vel value affects the Decay Time

Atk+Rls: The Time/Vel value affects the Attack Time and Release Time

All: The Time/Vel value affects the time-related settings in AEG

Half Damper (Half Damper Switch)

By setting this switch On, you can connect a separately sold foot controller FC3A to the [SUSTAIN] jack on the rear panel and use the half-damper function for your keyboard performance.

The Half-damper function gives you greater expressive control over sound decay, letting you use damper pedal operation just as you would on an acoustic piano—continuously and not just as an on/off switch.

Settings: Off, On

Time (Half Damper Time)

Sets the time from the moment you have released a key while you are pressing the foot controller FC3A fully down to when the sound decays when the Half Damper (Half Damper Switch) is set to On. This parameter is not shown when set to Off. You can adjust the decay time from the Half Damper Time to the Release Time (AEG Release Time) by changing the amount you press on the pedal.

When you release the pedal, the Release Time (AEG Release Time) is used for decaying sound. By setting the Release Time to a small value, and Half Damper Time to a large value, you can play a natural decaying sound, like on an acoustic piano.

Settings: 0–127

Scale

On the Scale screen, you can set the Amplitude Scale for the Element.
This changes the volume according to the key position on the keyboard.

Operation

[PERFORMANCE (HOME)] → [EDIT/↺] → Part selection → Element selection → Amplitude → Scale



Break Point (Level Scaling Break Point) 1–4

Sets the note number for Level Offset (Level Scaling Offset) 1–4.

Settings: C–2–G8

NOTE

The note numbers for Break Point 1 to 4 will be automatically arranged in ascending order.

Level Offset (Level Scaling Offset) 1–4

Sets the value that increases or decreases the Level on Break Point (Level Scaling Break Point) 1–4.

Settings: -128→+0→+127

Element EQ

On the Element EQ screen, you can set the equalizer for the Element.

Operation

[PERFORMANCE (HOME)] → [EDIT/↺] → Part selection → Element selection → Element EQ



EQ Type (Element EQ Type)

Selects the desired EQ type.

Settings: 2-band, P.EQ, Boost6, Boost12, Boost18, Thru

2-band: Shelving EQ that boosts or cuts the band of signals above or below a certain frequency (Low Freq or High Freq).

P.EQ: Parametric EQ that boosts or cuts the signal level (Gain) around the Center Frequency (Freq).

Boost6: Boosts the level by 6 dB.

Boost12: Boosts the level by 12 dB

Boost18: Boosts the level by 18 dB

Thru: Passes the signals with no effects being applied

■ When EQ Type is set to 2-band

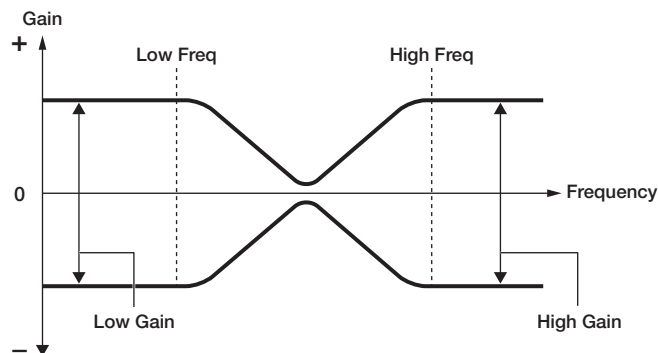

EQ Low Gain (Element EQ Low Gain)

Sets the signal level of the Low band.

Settings: -12.00dB – +0.00dB – +12.00dB

EQ Low Freq (Element EQ Low Frequency)

Sets the frequency of the Low band.

Settings: 50.1Hz–2.00kHz

EQ Hi Gain (Element EQ High Gain)

Sets the signal level of the High band.

Settings: -12.00dB – +0.00dB – +12.00dB

EQ Hi Freq (Element EQ High Frequency)

Sets the frequency of the High band.

Settings: 503.8Hz–10.1kHz

■ When EQ Type is set to P.EQ

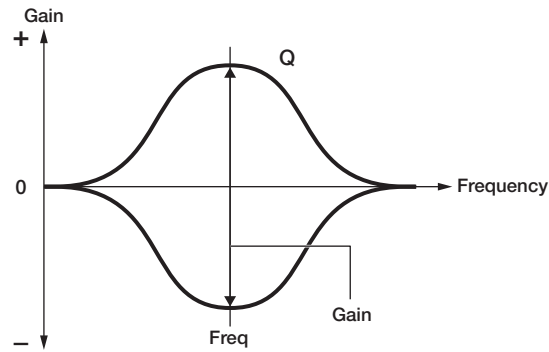

EQ Gain (Element EQ Gain)

Sets the signal level for the frequency range set in EQ Freq (Element EQ Frequency).

Settings: -12.00dB – +0.00dB – +12.00dB

EQ Freq (Element EQ Frequency)

Sets the frequency to be cut or boosted.

Settings: 139.7Hz–12.9kHz

EQ Q (Element EQ Q)

By boosting or cutting the signal level of the frequency set in EQ Freq (Element EQ Frequency), you can create various frequency response curves.

Settings: 0.7–10.3

Element LFO

On the Element LFO screen, you can set the LFO (Low Frequency Oscillator) for the Element. The LFO (Low Frequency Oscillator) for the Element generates signals in the low band, and you can use it for modulation (cyclical variation) of the pitch, filter, and amplitude.

Operation

[PERFORMANCE (HOME)] → [EDIT/↶] → Part selection → Element selection → Element LFO

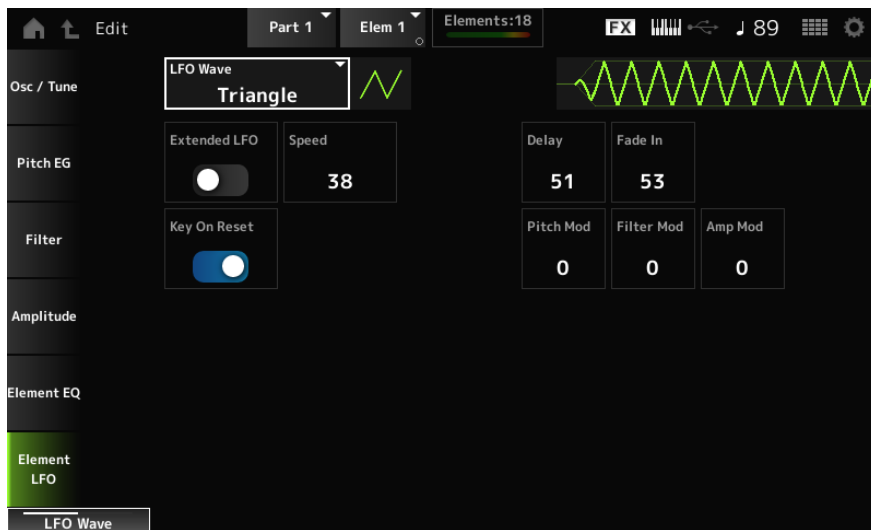

LFO Wave

Selects an LFO wave. By using the wave you have selected here, you can create various types of modulation.

Settings: Saw, Triangle, Square

Saw (Sawtooth wave)

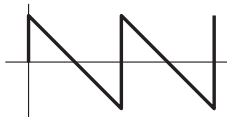

Triangle (Triangle wave)

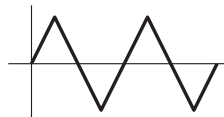

Square (Square wave)

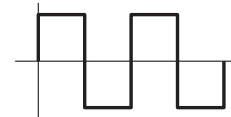

Extended LFO

Switches between the old set of Speed (LFO Speed) settings (Off: 0–63) and a new set of settings with higher resolution (On: 0–415) for Speed (LFO Speed).

To maintain compatibility of data created with the old settings, set this parameter to Off.

Settings: Off, On

Speed (LFO Speed)

Sets the speed of LFO Wave changes. The larger the value of this parameter, the faster the speed becomes.

Settings: 0–63 (Extended LFO set to Off), 0–415 (Extended LFO set to On)

Delay (LFO Delay Time)

Sets the delay time between the moment you press a key on the keyboard and the moment the LFO comes into effect.

Settings: 0–127

Fade In (LFO Fade In Time)

Sets the time length for the LFO effect to fade in after you have released the key and the delay time set in Delay (LFO Delay Time) has elapsed. The larger the value, the longer it takes for the LFO effect to reach the maximum.

Settings: 0–127

0: The LFO changes to the maximum value without any fade-ins.

When the value is small

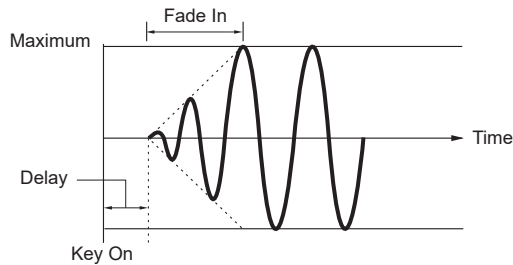

When the value is large

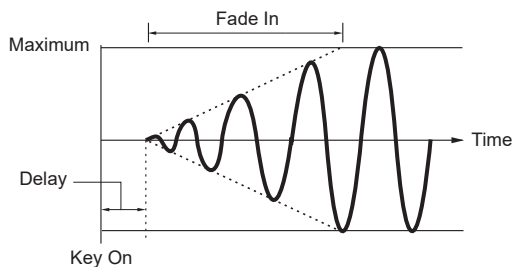

Key On Reset (LFO Key On Reset)

Resets the oscillation of the LFO when a key is pressed.

Settings: Off, On

Pitch Mod (LFO Pitch Modulation Depth)

This parameter creates a vibrato effect (cyclical changes to the pitch) by using LFO waves.

Setting the parameter to larger values results in greater change to the volume.

Settings: 0–127

Filter Mod (LFO Filter Modulation Depth)

This parameter creates a wah effect (cyclical changes to the filter cutoff frequency) by using LFO waves.

Larger values result in greater range for cutoff frequency changes.

Settings: 0–127

Amp Mod (LFO Amplitude Modulation Depth)

This parameter creates a tremolo effect (cyclical changes in the volume) by using LFO waves.

Setting the parameter to larger values results in greater change to the volume.

Settings: 0–127

Drum Part Edit (AWM2) Part Common Edit Screens

The Drum Part (AWM2) consists of 73 drum keys.

Drum Part Edit (AWM2) includes Part Common Edit (for setting parameters for the entire Part) and Key Edit (for setting parameters for individual drum keys).

General/Pitch

Part Settings

Operation

[PERFORMANCE (HOME)] → Part Common selection → [EDIT/↺] → General/Pitch → Part Settings

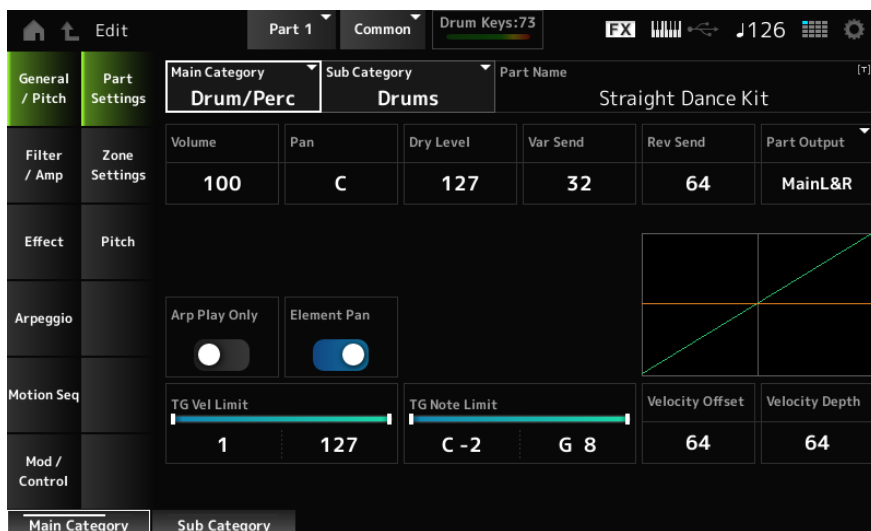

Main Category (Part Main Category)

Sub Category (Part Sub Category)

Sets the Main category and Sub category of the selected Part.

Settings: Refer to the Data List

Part Name

You can save the Part you are editing under a new name, You can use up to 20 alphanumeric characters.

Volume

Sets the volume of the selected Part.

Settings: 0–127

Pan

Adjusts the Pan position (in the stereo field) of the selected Part.

Settings: L63–C (center)–R63

Dry Level

Sets the Dry Level of the selected Part.

This parameter is available only when Part Output (Part Output Select) is set to MainL&R or Drum.

Settings: 0–127

Var Send (Variation Send)

Sets the Variation Send of the selected Part.

This parameter is available only when Part Output (Part Output Select) is set to MainL&R or Drum.

Settings: 0–127

Rev Send (Reverb Send)

Sets the Reverb Send of the selected Part.

This parameter is available only when Part Output (Part Output Select) is set to MainL&R or Drum.

Settings: 0–127

Part Output (Part Output Select)

Sets the output destination for the audio signals of the selected Part.

Settings: MainL&R, (AsgnL&R), USB Stereo, (AsgnL), (AsgnR), USB mono, Off, Drum

MainL&R: Outputs in stereo (two channels) to the OUTPUT [L/MONO] and OUTPUT [R] jacks.

USB Stereo: Outputs in stereo (channels 1 and 2, to channels 7 and 8) to the USB [TO HOST] terminal

USB mono: Outputs in mono (channels 1 to 8) to the USB [TO HOST] terminal

Off: No output of the audio signal for the Part.

Drum: You can set the output for each drum key.

NOTE

The settings for data compatibility with MONTAGE M are shown below. They are considered Off when set.

- AsgnL&R
- USB Stereo: USB9&10 – USB29&30
- USB mono: USB9 – USB30
- AsgnL
- AsgnR

Arp Play Only (Arpeggio Play Only)

Sets the Part to be played only with the Arpeggio.

Any Part set to On will be played by the Note On messages sent from the Arpeggio.

Settings: Off, On

Element Pan (Element Pan Switch)

Sets the Pan to On or Off from the Key Edit.

When set to Off, the Pan in the Key Edit will be set to C (center).

Settings: Off, On

Velocity Limit

Sets the velocity range (lowest and highest values) for the Part.

Settings: 1–127

Note Limit

Sets the note range (lowest and highest notes) for the Part.

Settings: C–2–G8

Velocity Offset (Velocity Sensitivity Offset)

Increases or decreases the velocity value that is sent to the internal tone generator.

Settings: 0–127

When Velocity Depth = 64
and Velocity Offset = 32

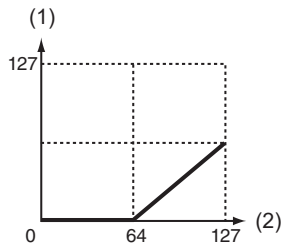

When Velocity Depth = 64
and Velocity Offset = 64

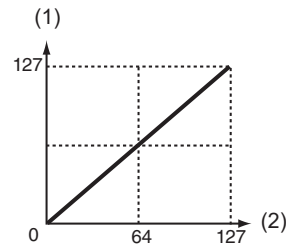

When Velocity Depth = 64
and Velocity Offset = 96

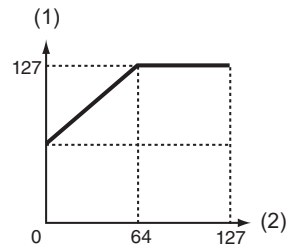

(1) Actual resulting velocity (affecting the tone generator)
(2) Velocity with which you play a note

Velocity Depth (Velocity Sensitivity Depth)

Sets how the level of the velocity value (sent to the internal tone generator) responds to Velocity or the strength of the keystroke.

Settings: 0–127

When Velocity Depth = 64

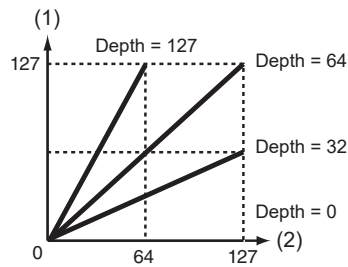

(1) Actual resulting velocity (affecting the tone generator)
(2) Velocity with which you play a note

Zone Settings

The same as General/Pitch → [Zone Settings](#) on the Part Edit (AWM2) Part Common Edit screen.

Pitch

On the Pitch screen, you can set the pitch for the Part.

Operation

[PERFORMANCE (HOME)] → Part Common selection → [EDIT/↺] → General/Pitch → Pitch

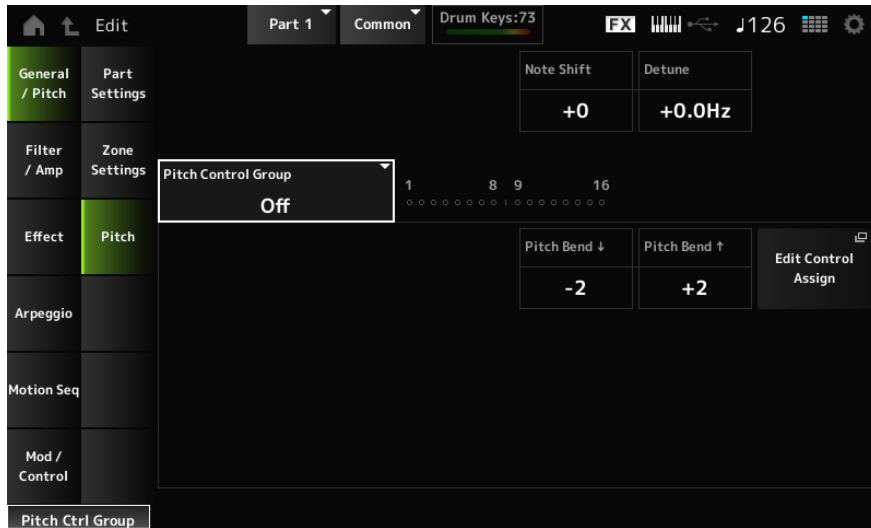

Note Shift

Adjusts the pitch in semitones.

Settings: -48+0+48

Detune

Adjusts the pitch of the selected Part in 0.1 Hz increments.

By slightly shifting the pitch, you can detune the sound.

Settings: -12.8Hz+0.0Hz+12.7Hz

Pitch Control Group

Parts assigned to the same group are given the same pitch.

However, Portamento, Mono/Poly, and Micro Tuning are not available for the Drum Part.

Pitch Bend↓ (Pitch Bend Range Lower)

Pitch Bend↑ (Pitch Bend Range Upper)

Sets the range of the changes created with the Pitch Bend wheel in semitones.

Settings: -48+0+24

Filter/Amp

Filter

The same as Filter/Amp → [Filter](#) on the Part Edit (AWM2) Part Common Edit screen.

Amp EG

The same as Filter/Amp → [Amp EG](#) on the Part Edit (AWM2) Part Common Edit screen.

Effect

Routing

On the Routing screen, you can set the effect routing for the Part.

Operation

[PERFORMANCE (HOME)] → Part Common selection → [EDIT/↺] → Effect → Routing

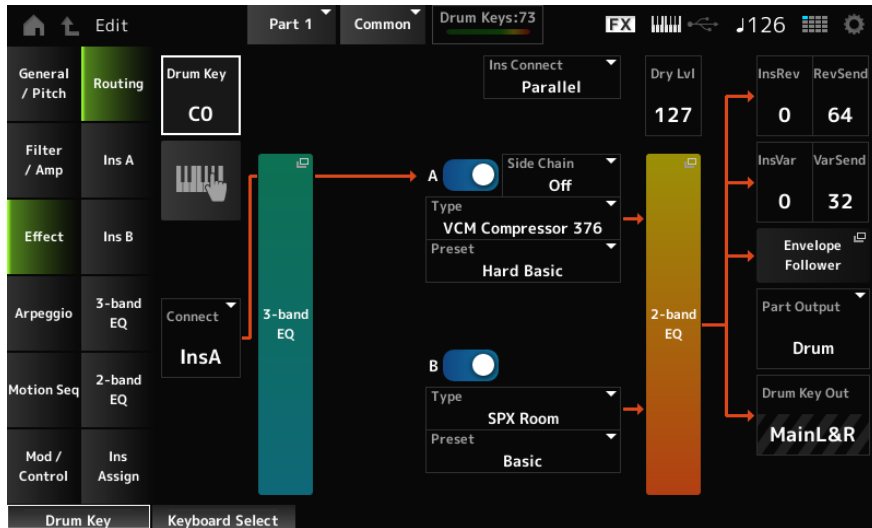

The screen here is basically the same as the one opened from Effect → [Routing](#) on the Part Edit (AWM2) Part Common Edit screen; however, the parameters added to Drum Part Edit (AWM2) are shown below.

Drum Key (Drum Key Select)

Shows the name of the selected Drum Key.

Settings: C0–C6

Keyboard Select

Sets the Keyboard select setting on or off.

When this parameter is set to On, you can select the desired drum key for editing by pressing a key on the keyboard.

Settings: Off, On

Connect (Drum Key Connection Switch)

Sets the Key to be output to Insertion Effect A (InsA) or Insertion Effect B (InsB), or bypasses the Insertion Effect (Thru).

Settings: Thru, InsA, InsB

InsRev (Insertion to Reverb Send Level)

InsVar (Insertion to Variation Send Level)

Sets the level of the Drum Key signals sent to Insertion Effect A or Insertion Effect B to the Reverb or Variation Effect.

This setting is applied to the entire Drum Part (all Drum Keys).

This parameter is available only when Connect (Drum Key Connection Switch) is set to InsA or InsB, and Part Output (Part Output Select) is set to MainL&R or Drum.

Settings: 0–127

KeyRev (Drum Key Reverb Send Level)

KeyVar (Drum Key Variation Send Level)

Sets the level of the drum key signals sent through Insertion Effect A or Insertion Effect B to the Reverb or Variation Effect.

This parameter can be set to each drum key.

This parameter is available only when Connect (Drum Key Connection Switch) is set to Thru, Part Output (Part Output Select) and is set to MainL&R, or when Part Output is set to Drum and Drum Key Out is set to MainL&R.

Settings: 0–127

Drum Key Out (Drum Key Output Select)

Sets the output destination for each Drum Key.

This parameter is shown only when Part Output (Part Output Select) is set to Drum.

Settings: MainL&R, (AsgnL&R), USB Stereo, (AsgnL), (AsgnR), USB mono

MainL&R: Outputs in stereo (two channels) to the OUTPUT [L/MONO] and OUTPUT [R] jacks.

USB Stereo: Outputs in stereo (channels 1 and 2, to channels 7 and 8) to the USB [TO HOST] terminal

USB mono: Outputs in mono (channels 1 to 8) to the USB [TO HOST] terminal

NOTE

- The settings for data compatibility with MONTAGE M are shown below. They are considered Off when set.
 - AsgnL&R
 - USB Stereo: USB9&10 – USB29&30
 - USB mono: USB9 – USB30
 - AsgnL
 - AsgnR
- Connect (Drum Key Connection Switch) is set to InsA/InsB, this parameter is fixed to MainL&R.

Ins A, Ins B

On the Ins A and Ins B screens, you can set the Insertion Effects.

Operation

[PERFORMANCE (HOME)] → Part Common selection → [EDIT/↺] → Effect → Ins A

[PERFORMANCE (HOME)] → Part Common selection → [EDIT/↺] → Effect → Ins B

The same as Audio In → [Ins A, Ins B](#) on the Common Edit screen.

3-band EQ

The same as Effect → [3-band EQ](#) on the Part Edit (AWM2) Part Common Edit screen.

2-band EQ

The same as Effect → [2-band EQ](#) on the Part Edit (AWM2) Part Common Edit screen.

Ins Assign

The same as Effect → [Ins Assign](#) on the Part Edit (AWM2) Part Common Edit screen.

Arpeggio

Common

The same as Arpeggio → [Common](#) on the Part Edit (AWM2) Part Common Edit screen.

Individual

The same as Arpeggio → [Individual](#) on the Part Edit (AWM2) Part Common Edit screen.

Advanced

The screen here is basically the same as the one opened from Arpeggio → [Advanced](#) on the Part Edit (AWM2) Part Common Edit screen; however, the parameter shown below has been added.

Fixed SD/BD (Arpeggio Fixed SD/BD)

When this parameter is set to On, Arpeggio playback uses C1 for the bass drum and D1 for the snare drum.

Most drum kits assign the bass drum to C1 and the snare drum to D1, but some drum kits may assign different notes.

Therefore, depending on the combination of the selected drum kit and Arpeggio Type, it may sound unnatural. Turning this parameter on may resolve this unnatural sound.

Settings: Off, On

Motion Seq

Common

The same as Motion Seq → [Common](#) on the Part Edit (AWM2) Part Common Edit screen.

Lane

The same as Motion Seq → [Lane](#) on the Part Edit (AWM2) Part Common Edit screen.

Control Assign

Other than the Destination setting, the same as Mod/Control → [Control Assign](#) on the Part Edit (AWM2) Part Common Edit screen.

For the list of Destination settings, refer to the Control List on the Data List.

Tx/Rx Switch

The same as Mod/Control → [Tx/Rx Switch](#) on the Part Edit (AWM2) Part Common Edit screen.

Control Settings

The same as Mod/Control → [Control Settings](#) on the Part Edit (AWM2) Part Common Edit screen.

Drum Part Edit (AWM2) Key Edit screen

The Drum Part (AWM2) consists of 73 drum keys.

Drum Part Edit (AWM2) includes Part Common Edit (for setting parameters for the entire Part) and Key Edit (for setting parameters for individual drum keys).

Osc/Tune

On the Osc/Tune screen, you can set the Oscillator for each key within the Drum Part.

Operation

[PERFORMANCE (HOME)] → [EDIT/↶↷] → Part selection → Key selection → Osc/Tune

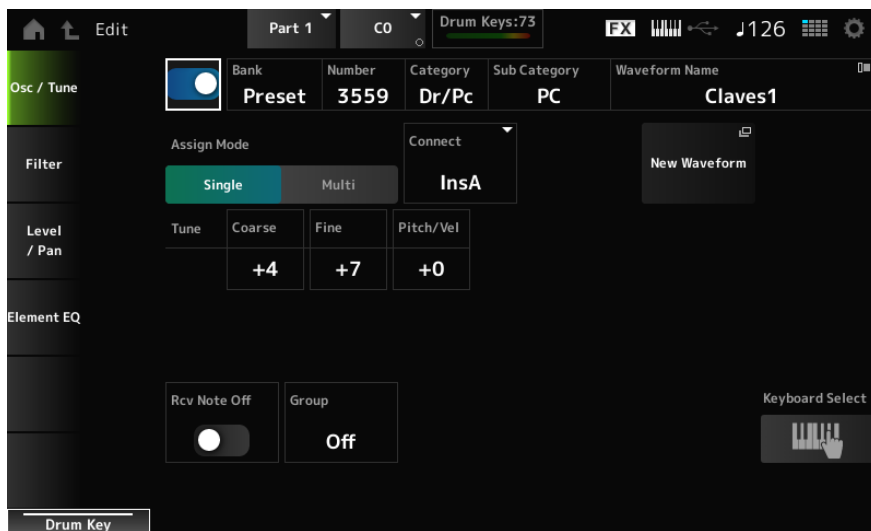

Drum Key Switch

Sets the selected Drum Key to use.

Settings: Off, On

Bank (Waveform Bank)

Number (Waveform Number)

Category (Waveform Category)

Sub Category (Waveform Sub Category)

Waveform Name

Shows the name of the Waveform selected for the Drum Key.

Bank indicates the type of Waveform (Preset, User, and Library) assigned to the Element.

Settings: Refer to the Data List

Assign Mode (Key Assign Mode)

Sets how sound is produced when the internal tone generator receives Note On messages of the same sound twice (or more) in a row. The Multi setting makes rolls sound natural, especially crash cymbals or other percussion instruments having a long decay.

Settings: Single, Multi

Single: Stops the first note and then plays the same note again.

Multi: Plays the second note over the first note

Connect (Drum Key Connection)

Sets the Key to be output to Insertion Effect A (InsA) or Insertion Effect B (InsB), or bypasses the Insertion Effect (Thru). This parameter is the same as Effect → Routing Connect (Drum Key Connection Switch) on the Drum Part Edit (AWM2) Part Common Edit screen.

Settings: Thru, InsA, InsB

New Waveform

Loads an audio file saved to USB flash drive as a Waveform.

Edit Waveform appears when a Waveform is loaded.

Edit Waveform

The Waveform Edit screen will open.

Coarse (Coarse Tune)

Shifts the pitch of the waveform assigned to the Drum Key.

Settings: -48→+0→+48

Fine (Fine Tune)

Finely adjusts the pitch of the wave assigned to the Drum Key.

Settings: -64→+0→+63

Pitch/Vel (Pitch Velocity Sensitivity)

Sets how the pitch change responds to Velocity or the strength of the keystroke.

Settings: -64→+0→63

Positive value: The faster the Velocity, the higher the pitch becomes

0: kept unchanged

Negative value: The faster the Velocity, the lower the pitch becomes

Rcv Note Off (Receive Note Off)

Sets the drum key to receive MIDI note-off messages. Set this to On for percussion instrument sounds to make them last without decay.

Settings: Off, On

On: The sound stops when release the key

Off: The sound decays after you release the key

Group (Alternate Group)

This setting helps you to prevent improper or unnatural combinations of drum keys to be played together.

For example, you can assign open and closed hi-hats to the same Group so that you can avoid them being played together.

For drum keys that can be played naturally with any combination, set this parameter to Off.

Settings: Off, 1–127

KeyRev (Drum Key Reverb Send Level)

KeyVar (Drum Key Variation Send Level)

Sets the level of the drum key signals sent through Insertion Effect A or Insertion Effect B to the Reverb or Variation Effect.

This parameter can be set to each drum key.

This parameter is not available depending on the Connect (Drum Key Connection Switch), Part Output (Part Output Select), and Drum Key Out (Drum Key Output Select) settings.

Settings: 0–127

Drum Key Out (Drum Key Output Select)

Sets the output destination for the Drum Key.

This parameter is not available depending on the Connect (Drum Key Connection Switch) and Part Output (Part Output Select) settings.

Settings: MainL&R, (AsgnL&R), USB Stereo, (AsgnL), (AsgnR), USB Mono

MainL&R: Outputs in stereo (two channels) to the OUTPUT [L/MONO] and OUTPUT [R] jacks.

USB Stereo: Outputs in stereo (channels 1 and 2, to channels 7 and 8) to the USB [TO HOST] terminal

USB Mono: Outputs in mono (channels 1 to 8) to the USB [TO HOST] terminal

NOTE

The settings for data compatibility with MONTAGE M are shown below. They are considered Off when set.

- AsgnL&R
- USB Stereo: USB9&10 – USB29&30
- USB mono: USB9 – USB30
- AsgnL
- AsgnR

Keyboard Select

Sets the Keyboard select setting on or off.

When this parameter is set to On, you can select the desired drum key for editing by pressing a key on the keyboard.

Settings: Off, On

Filter

Sets the filter for the Drum Part. You can change the tone quality by using a low pass filter and high pass filter on each drum key.

Operation

[PERFORMANCE (HOME)] → [EDIT/EDIT] → Part selection → Key selection → Filter



Cutoff (LPF Cutoff Frequency)

Sets the cutoff frequency for the low pass filter.

Settings: 0–1023

Cutoff/Vel (LPF Cutoff Velocity Sensitivity)

Sets the velocity sensitivity to the cutoff frequency of the low pass filter.

For positive values of this parameter, the stronger (higher velocity) you play the key, the higher the cutoff frequency becomes.

For negative values of this parameter, the stronger you play the key, the lower the cutoff frequency becomes.

Settings: -64–+0–+63

Resonance (LPF Resonance)

Sets the level of the resonance effect on the low pass filter.

Settings: 0–127

HPF Cutoff (HPF Cutoff Frequency)

Sets the cutoff frequency of the high pass filter.

Settings: 0–1023

Level/Pan

Sets the Level and Pan (position in the stereo field) for each Drum Key.

Operation

[PERFORMANCE (HOME)] → [EDIT/↺] → Part selection → Key selection → Level/Pan

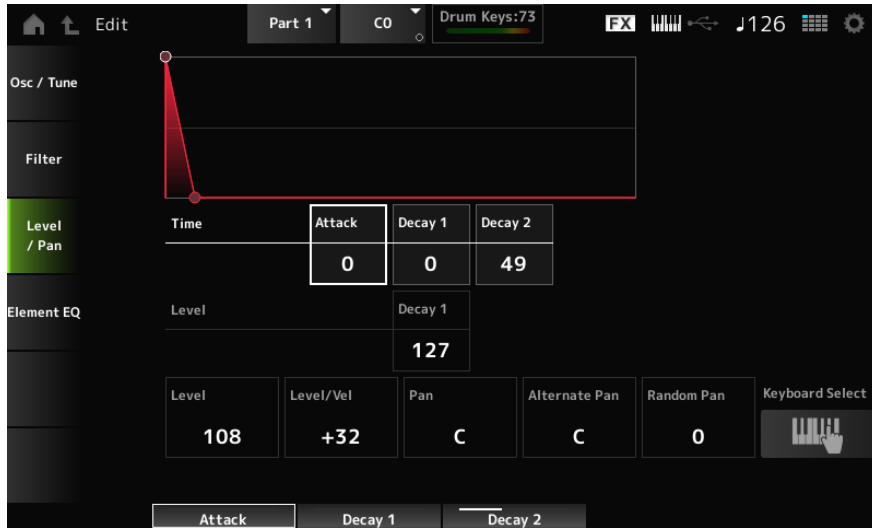

Attack Time (AEG Attack Time)

Sets the length of time it takes for the volume to change from the moment you press a key on the keyboard until the time the volume reaches the value set at the Level (Drum Key Level).

Settings: 0–127

Decay 1 Time (AEG Decay 1 Time)

Sets the length of time it takes for the volume to change from the Level (Drum Key Level) to the Decay 1 Level (AEG Decay 1 Level).

Settings: 0–127

Decay 2 Time (AEG Decay 2 Time)

Sets the length of time it takes for the volume to decay after reaching the volume set in Decay 1 Level (AEG Decay 1 Level).

Settings: 0–126, Hold

Decay 1 Level (AEG Decay 1 Level)

Sets the next volume value to change from the Level (Drum Key Level).

Settings: 0–127

Level (Drum Key Level)

Sets the output level for the Drum Key. This parameter lets you adjust the level balance among the drum keys.

Settings: 0–127

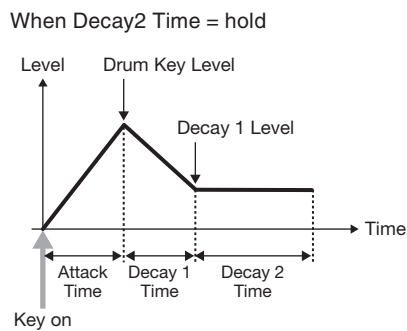
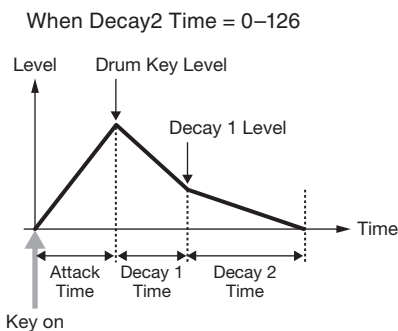

Level/Vel (Level Velocity Sensitivity)

Sets how Level (Volume) responds to Velocity or the strength of the keystroke.

Settings: -64 - +0 - +63

Positive value: The faster the Velocity, the louder the volume becomes

0: No change regardless of the velocity setting.

Negative value: The slower the Velocity, the louder the volume becomes

Pan

Sets the Pan (location in the sound field) of the drum key. You can adjust the position in the stereo field for the Drum Part (Drum Kit).

Settings: L63 - C (center) - R63

Alternate Pan (Alternate Pan Depth)

Sets how the sound is panned alternately left and right for each key played.

The value set in Pan is the center position for the right and left movement of the Pan.

Settings: L63 - C (Center) - R63

Random Pan (Random Pan Depth)

Sets how the sound is panned randomly left and right for each key played.

The value set in Pan is the center position in the stereo field.

Settings: 0 - 127

Element EQ

The same as [Element EQ](#) on the Part Edit (AWM2) Element Edit screen.

Part Edit (FM-X) Part Common Edit Screens

The Normal Part (FM-X) consists of eight Operators.

Part Edit (FM-X) includes Part Common Edit (for setting parameters for the entire Part) and Operator Edit (for setting parameters for individual operators).

General/Pitch

Part Settings

On the Part Settings screen, you can set general parameters (such as the Part names and tone generation system) for the Part.

Operation

[PERFORMANCE (HOME)] → Part Common selection → [EDIT/↺] → General/Pitch → Part Settings

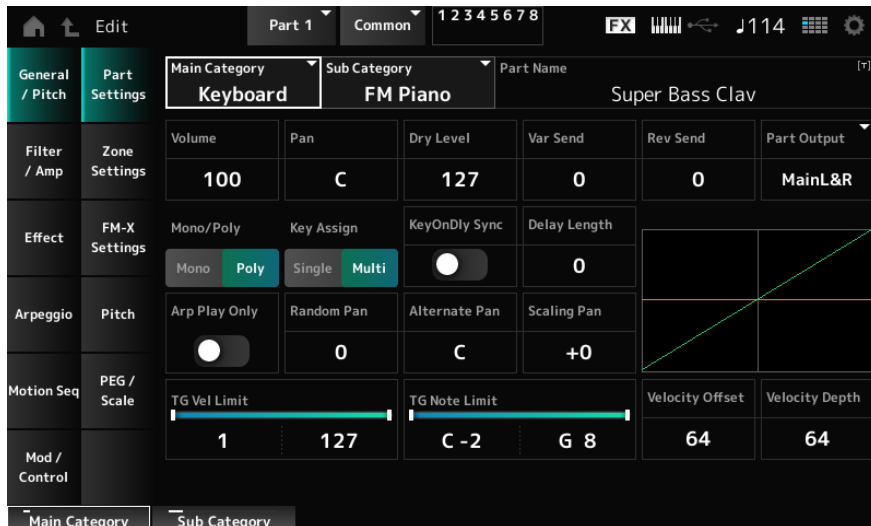

The screen here is the same as the one opened from General/Pitch → [Part Settings](#) on the Part Edit (AWM2) Part Common Edit screen; however, the parameter shown below has been added.

Random Pan (Random Pan Depth)

Sets how the sound is panned randomly left and right for each key played.

The value set in Pan is the center position in the stereo field.

Settings: 0–127

Alternate Pan (Alternate Pan Depth)

Sets how the sound is panned alternately left and right for each key played.

The value set in Pan is the center position for the right and left movement of the Pan.

Settings: L63–C (Center)–R63

Scaling Pan (Scaling Pan Depth)

Sets how the position of the key you press affects the position of the Pan setting. Note Number C3 is the reference point for panning, and the position at this time is the value set in Pan.

By setting this parameter to a positive value, Pan is set to the left for lower keys, and to the right for higher keys.

When this parameter is set to a value of 0, there will be no changes to the Pan setting. When the parameter is set to a negative value, the pan is set to the left for lower keys, and to the right for higher keys.

Settings: –64–+0–+63

KeyOnDly Sync (Key On Delay Tempo Sync)

Sets the timing of the Key On Delay to synchronize with the tempo.

Settings: Off, On

Delay Length (Key On Delay Time Length)

Sets the delay time from when the moment the key is pressed to when sound is produced.

This parameter is not available when KeyOnDly Sync is set to On.

Settings: 0–127

Delay Length (Key On Delay Note Length)

This parameter is available when KeyOnDly Sync (Key On Delay Tempo Sync) is set to On. You can set the timing for Key On Delay by using musical note values.

Settings: 1/16 (sixteenth notes), 1/8 Tri. (eighth-note triplets), 1/16 Dot. (dotted sixteenth notes), 1/8 (eighth notes), 1/4 Tri. (quarter-note triplets), 1/8 Dot. (dotted eighth notes), 1/4 (quarter notes), 1/2 Tri. (half-note triplets), 1/4 Dot. (dotted quarter notes), 1/2 (half notes), Whole Tri. (whole-note triplets), 1/2 Dot. (dotted half notes), 1/4 × 4 (quarter-note quadruplets; four quarter notes to the beat), 1/4 × 5 (quarter-note quintuplets; five quarter notes to the beat), 1/4 × 6 (quarter-note sextuplets; six quarter notes to the beat), 1/4 × 7 (quarter-note septuplets; seven quarter notes to the beat), 1/4 × 8 (quarter-note octuplets; eight quarter notes to the beat)

Zone Settings

The same as General/Pitch → [Zone Settings](#) on the Part Edit (AWM2) Part Common Edit screen.

FM-X Settings

On the FM-X Settings screen, you can set the FM Color parameters provided as a convenient editing tool for the FM-X sounds as well as the Algorithm (or how the Operators are arranged).

Operation

[PERFORMANCE (HOME)] → Part Common selection → [EDIT/↺] → General/Pitch → FM-X Settings



FM Attack

Controls the Attack Time of the EG that changes the depth of the frequency modulation over time.
Settings: -99~+0~+99

FM Decay

Controls the Decay Time of the EG that changes the depth of the frequency modulation over time.
Settings: -99~+0~+99

FM Sustain

Controls the Sustain Level of the EG that changes the depth of the frequency modulation over time.
Settings: -99~+0~+99

FM Release

Controls the Release Time of the EG that changes the depth of the frequency modulation over time.
Settings: -99~+0~+99

Algorithm (Algorithm Number)

Changes the Algorithm.
Settings: Refer to the Data List

Feedback (Feedback Level)

Feedback causes the Operator to modulate itself by sending some of the output signals back.
Here with this parameter, you can set the degree of such modulation.
Settings: 0~7

FM Depth

Changes the depth of the frequency modulation.

Settings: -99+0+99

FM Harmonics

Changes the frequency of the harmonic overtones of FM synthesis.

Settings: -99+0+99

FM Texture

Changes the texture of FM synthesis.

Settings: -99+0+99

Algorithm Search

Opens the Algorithm Search screen.

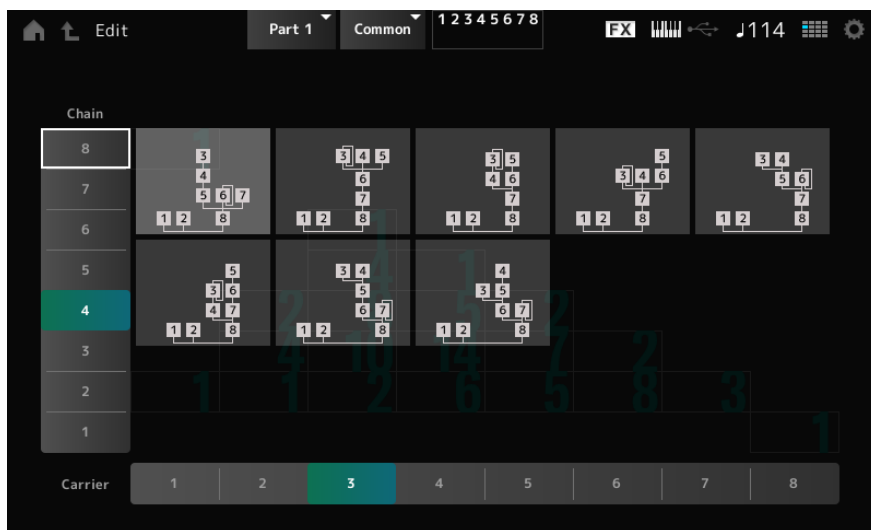

- **Chain**
Filters the available algorithms based on the maximum length of the operators connected in series.
- **Carrier**
Filters the available algorithms based on number of carriers.

Filter Offset Cutoff (Filter Cutoff Frequency)

Changes the sound by setting the cutoff frequency of the filter. When the Low Pass Filter is selected, larger values here result in a brighter sound, and smaller values result in a darker sound.

This parameter is specified as an offset value to the filter cutoff frequency.

Settings: -64+0+63

Filter Offset Resonance (Filter Offset Resonance/Width)

Adds special characteristics to the sound by adjusting the signal level near the cutoff frequency.

This is specified as an offset value to the filter resonance.

Settings: -64+0+63

Filter Offset FEG Depth

Sets the depth range for the cutoff frequency change controlled by the FEG.

Settings: -64+0+63

Filter Type

The Filter Type screen will open.

Filter EG

The Filter EG screen will open.

Pitch

The screen here is the same as the one opened from General/Pitch → [Pitch](#) on the Part Edit (AWM2) Part Common Edit screen, except that Legato Slope (Portamento Legato Slope) is disabled.

PEG/Scale

On the PEG/Scale screen, you can set the pitch envelope generator and scale for the Part.

Operation

[PERFORMANCE (HOME)] → Part Common selection → [EDIT/

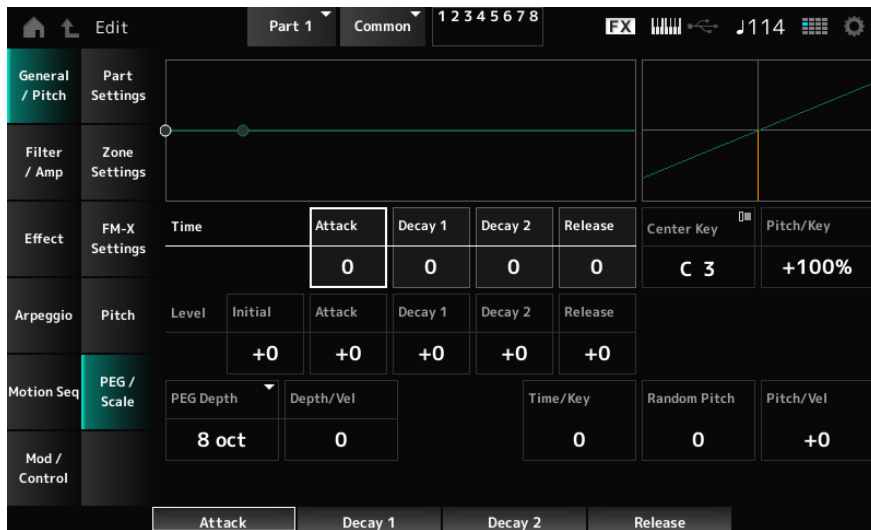

Attack Time (PEG Attack Time)

Sets the length of time it takes for the pitch to change from the moment you press a key on the keyboard until the time the pitch reaches the value set at Attack Level (PEG Attack Level).

Settings: 0–99

Decay1 Time (PEG Decay 1 Time)

Sets the length of time it takes for the pitch to change from the Attack Level (PEG Attack Level) to the Decay1 Level (PEG Decay 1 Level).

Settings: 0–99

Decay2 Time (PEG Decay 2 Time)

Sets the length of time it takes for the pitch to change from the Decay1 Level (PEG Decay 1 Level) to the Decay2 Level (PEG Decay 2 Level).

Settings: 0–99

Release Time (PEG Release Time)

Sets the length of time it takes for the pitch to change from the moment you have released the key until it reaches the Release Level (PEG Release Level).

Settings: 0–99

Center Key (Pitch Key Follow Sensitivity Center Key)

Sets the reference key for Pitch/Key (Pitch Key Follow Sensitivity).

Settings: C–2–G8

Pitch/Key (Pitch Key Follow Sensitivity)

Sets the difference in pitch between two adjacent keys. The note set in Center Key (Pitch Key Follow Sensitivity Center Key) is used as the reference.

Settings: -200%—+0%—+200%

+100% (default): Pitch difference between the two keys next to each other is set to a semitone

0%: No pitch difference between the two keys, and all keys are played at the pitch set in Center Key (Pitch Key Follow Sensitivity Center Key)

Negative value: Sets an opposite pitch response such that lower notes result in higher pitch, and higher notes result in lower pitch.

Initial Level (PEG Initial Level)

Sets the pitch for the moment you press the key.

Settings: -50—+0—+50

Attack Level (PEG Attack Level)

Sets the pitch to change from Initial Level (PEG Initial Level) after you have pressed a key.

Settings: -50—+0—+50

Decay1 Level (PEG Decay 1 Level)

Sets the next pitch value to change from the Attack Level (PEG Attack Level).

Settings: -50—+0—+50

Decay2 Level (PEG Decay 2 Level)

Sets the next pitch value to change from the Decay1 Level (PEG Decay 1 Level).

Settings: -50—+0—+50

Release Level (PEG Release Level)

Sets the final pitch to reach after you have released the key.

Settings: -50—+0—+50

PEG Depth

Sets the amount of pitch change controlled by the PEG.

Settings: 8 oct, 2 oct, 1 oct, 0.5 oct

NOTE

When this parameter is set to 8 oct, you can specify the smallest value to the Pitch EG level to create a pitch change of -4 octaves by sending the pitch value 0 to the internal tone generator, and by specifying the largest value to create a pitch change of +4 octaves.

Depth/Vel (PEG Depth Velocity Sensitivity)

Sets how the time of the pitch change in PEG responds to Velocity or the strength of the keystroke.

Settings: 0-7

Time/Key (PEG Time Key Follow Sensitivity)

Sets how the speed of the pitch change in PEG responds to key position.

Center Key (Pitch Key Follow Sensitivity Center Key): The speed change in PEG is used for the specified key fixed to C3.

Settings: 0-7

Positive value: The lower the key played, the slower the change in the PEG; the higher the key played, the faster the change in the PEG.

0: No PEG changes regardless of the key position

Random Pitch (Random Pitch Depth)

Changes the pitch of the Element randomly each time the key is pressed.

Settings: 0-127

Pitch/Vel (Pitch Velocity Sensitivity)

Sets how the pitch responds to Velocity or the strength of the keystroke.

Settings: -64—+0—+63

Positive value: The faster the Velocity, the higher the pitch becomes

0: kept unchanged

Negative value: The faster the Velocity, the lower the pitch becomes

Filter Type

The same as Filter → [Type](#) on the Part Edit (AWM2) Element Edit screen.

Filter EG

The same as Filter → [Filter EG](#) on the Part Edit (AWM2) Element Edit screen.

Filter Scale

The same as Filter → [Scale](#) on the Part Edit (AWM2) Element Edit screen.

Amp EG

The same as Filter/Amp → [Amp EG](#) on the Part Edit (AWM2) Part Common Edit screen.

Routing

The screen here is almost the same as the one opened from Effect → [Routing](#) on the Part Edit (AWM2) Part Common Edit screen, with the exceptions listed below.

- No output setting for each Element
- Cannot select Parallel for Ins Connect

Ins A, Ins B

The same as Audio In → [Ins A, Ins B](#) on the Common Edit screen.

3-band EQ

The same as Effect → [3-band EQ](#) on the Part Edit (AWM2) Part Common Edit screen.

2-band EQ

The same as Effect → [2-band EQ](#) on the Part Edit (AWM2) Part Common Edit screen.

Ins Assign

The same as Effect → [Ins Assign](#) on the Part Edit (AWM2) Part Common Edit screen.

Arpeggio

Common

The same as Arpeggio → [Common](#) on the Part Edit (AWM2) Part Common Edit screen.

Individual

The same as Arpeggio → [Individual](#) on the Part Edit (AWM2) Part Common Edit screen.

Advanced

The same as Arpeggio → [Advanced](#) on the Part Edit (AWM2) Part Common Edit screen.

Motion Seq

Common

The same as Motion Seq → [Common](#) on the Part Edit (AWM2) Part Common Edit screen.

Lane

The same as Motion Seq → [Lane](#) on the Part Edit (AWM2) Part Common Edit screen.

Control Assign

Operation

[PERFORMANCE (HOME)] → Part Common selection → [EDIT/↺] → Mod/Control → Control Assign

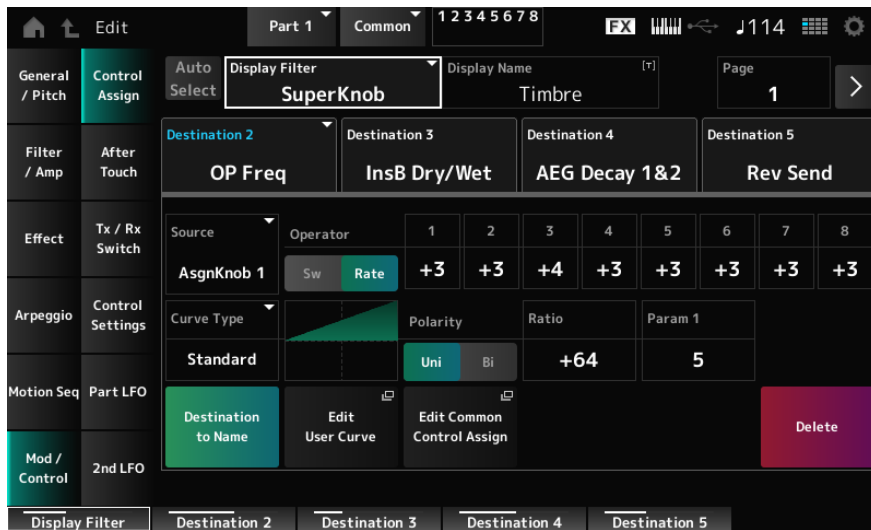

Other than the Destination setting, the same as Mod/Control → [Control Assign](#) on the Part Edit (AWM2) Part Common Edit screen.

For a list of settings, refer to the Data List.

Use the parameters shown below, instead of ElementSw and others.

Operator Sw 1–8 (Operator Switch)

You can set the controller setting for each Operator on or off. This parameter is shown only when the selected Destination is related to Operators.

Settings: Off, On

Sw/Rate

Switches the view between Operator Sw and Operator Rate.

This parameter is shown only when the Destination is set to OP Freq or OP AEG Offset.

Settings: Off, On

Operator Rate 1–8

Sets the sensitivity of the controller selected for the Destination.

This parameter is shown only when the Destination is set to OP Freq or OP AEG Offset.

Settings: -7-+0-+7

After Touch

Other than the Destination setting, the same as Mod/Control → [After Touch](#) on the Part Edit (AWM2) Part Common Edit screen.

Tx/Rx Switch

The same as Mod/Control → [Tx/Rx Switch](#) on the Part Edit (AWM2) Part Common Edit screen.

Control Settings

The same as Mod/Control → [Control Settings](#) on the Part Edit (AWM2) Part Common Edit screen.

Part LFO

On the Part LFO screen, you can set the Part LFO.

Operation

[PERFORMANCE (HOME)] → Part Common selection → [EDIT/↺] → Mod/Control → Part LFO

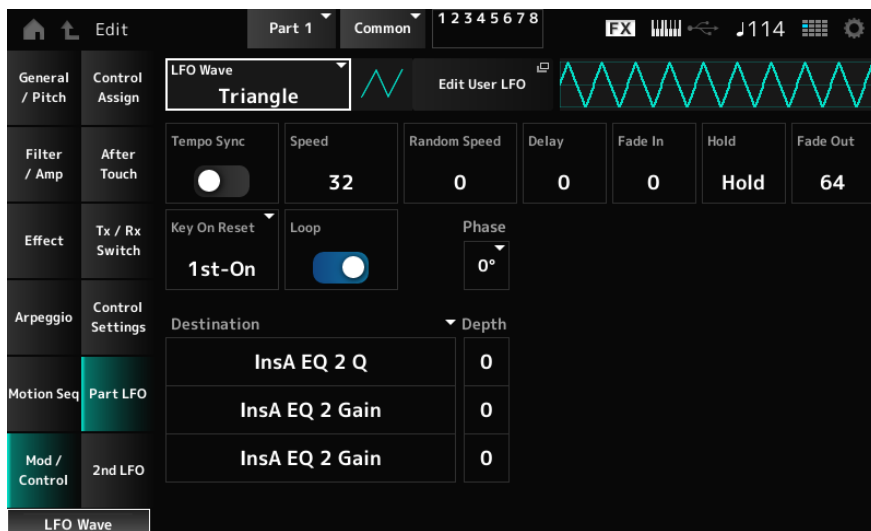

LFO Wave

Selects the LFO Wave and sets the type of cyclical changes to the LFOs.

Settings: Triangle, Triangle+, Saw Up, Saw Down, Squ1/4, Squ1/3, Square, Squ2/3, Squ3/4, Trapezoid, S/H1, S/H2, User

Edit User LFO

The User LFO Edit screen will open.

You can create an LFO waveform of up to 16 steps.

Tempo Sync (LFO Tempo Sync)

Sets the speed of the LFO Wave changes to synchronize to Arpeggio or Song playback.

Settings: Off (not synchronized), On (synchronized)

• When set to Off

Speed (LFO Speed)

Sets the speed of LFO Wave changes.

This parameter is not available when Tempo Sync (LFO Tempo Sync) is set to On.

Settings: 0–63

Random Speed (Part LFO Random Speed Depth)

Changes the LFO Speed randomly.

This parameter is not available when Tempo Sync (LFO Tempo Sync) is set to On.

Settings: 0–127

• When set to On

Tempo Speed (LFO Tempo Speed)

Sets the speed of LFO Wave changes by using musical note values.

Settings: 1/16 (sixteenth notes), 1/8 Tri. (eighth-note triplets), 1/16 Dot. (dotted sixteenth notes), 1/8 (eighth notes), 1/4 Tri. (quarter-note triplets), 1/8 Dot. (dotted eighth notes), 1/4 (quarter notes), 1/2 Tri. (half-note triplets), 1/4 Dot. (dotted quarter notes), 1/2 (half notes), Whole Tri. (whole-note triplets), 1/2 Dot. (dotted half notes), 1/4 × 4 (quarter-note quadruplets; four quarter notes to the beat), 1/4 × 5 (quarter-note quintuplets; five quarter notes to the beat), 1/4 × 6 (quarter-note sextuplets; six quarter notes to the beat), 1/4 × 7 (quarter-note septuplets; seven quarter notes to the beat), 1/4 × 8 (quarter-note octuplets; eight quarter notes to the beat), 1/4 × 16 (sixteen quarter-notes to the beat), 1/4 × 32 (thirty-two quarter-notes to the beat), 1/4 × 64 (sixty-four quarter-notes to the beat)

Delay (LFO Delay Time)

Sets the delay time between the moment you press a key on the keyboard and the moment the LFO comes into effect.

The larger the value, the longer the delay time for the LFO to come into effect.

Settings: 0–127

Fade In (LFO Fade In Time)

Sets the time length for the LFO effect to fade in after you have released the key and the delay time set in Delay (LFO Delay Time) has elapsed. The larger the value, the longer it takes for the LFO effect to reach the maximum.

Settings: 0–127

0: The LFO changes to the maximum value without any fade-ins.

When the value is small

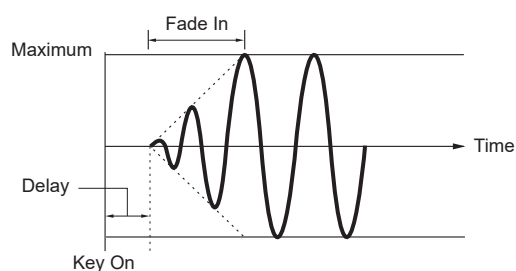

When the value is large

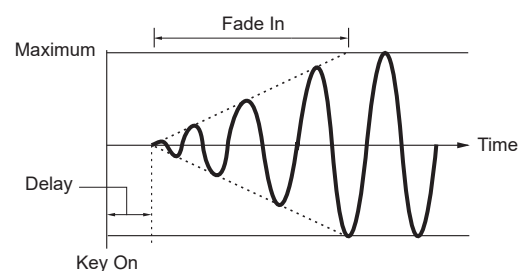

Hold (LFO Hold Time)

Sets the time for maintaining the LFO effect after the maximum level has been reached.

Settings: 0–126, Hold

Hold: Does not fade out

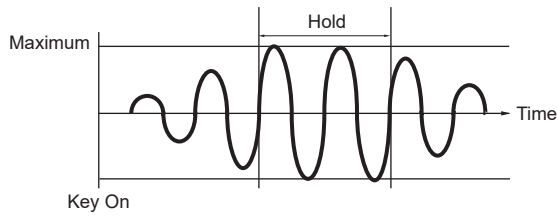

Fade Out (LFO Fade Out time)

Sets the amount of time for the LFO effect to fade out after the hold time set in Hold (LFO Hold Time) has elapsed. The larger the value, the longer it takes for the LFO effect to fade out.

Settings: 0–127

When the value is small

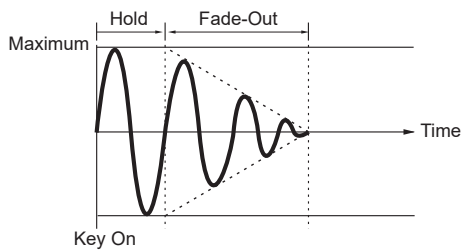

When the value is large

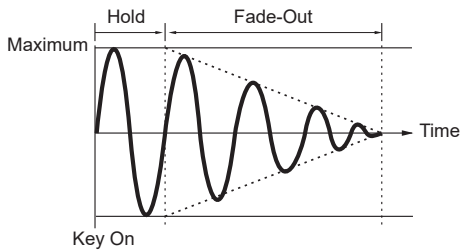

Key On Reset (LFO Key On Reset)

Resets the oscillation of the LFO when a key is pressed.

Settings: Off, Each-on, 1st-on

When set to Off

Does not reset the oscillation of the LFO. Pressing a key starts the LFO wave at whatever phase the LFO happens to be at that moment.

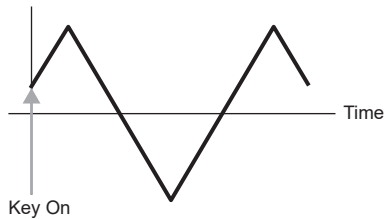

When set to Each-on

Resets the oscillation of LFO every time a key is pressed and starts the waveform at the phase specified by the Phase parameter.

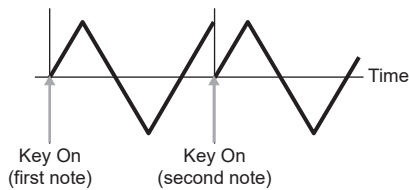

When set to 1st-on

Resets the oscillation of LFO every time a key is pressed and starts the waveform at the phase specified by the Phase parameter.

When the second note is played while the first note is held, playback will not be reset.

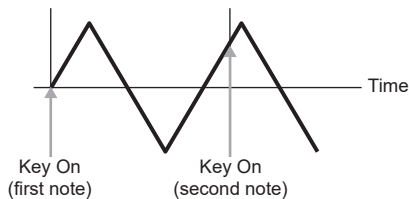

Loop (LFO Loop Switch)

Sets the LFO Wave to loop (repeat) playback or one-shot playback.

Settings: Off, On

Phase (LFO Phase)

You can set the initial phase for the time the LFO Wave is reset.

Settings: 0°, 90°, 120°, 180°, 240°, 270°

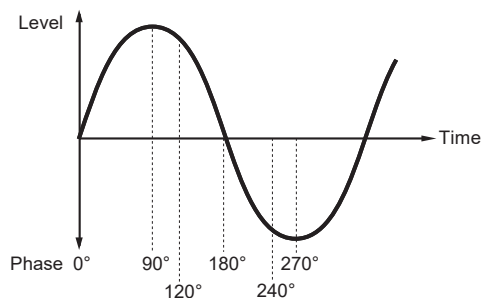

Destination (LFO Destination)

Sets the function to be controlled by the LFO Wave.

Settings: Insertion Effect A Parameter1–24, Insertion Effect B Parameter1–24 (depending on the Insertion Effect)

Depth (LFO Depth)

Sets the depth of LFO Wave control for each Destination.

Settings: 0–127

2nd LFO

Operation

[PERFORMANCE (HOME)] → Part Common selection → [EDIT/↺] → Mod/Control → 2nd LFO

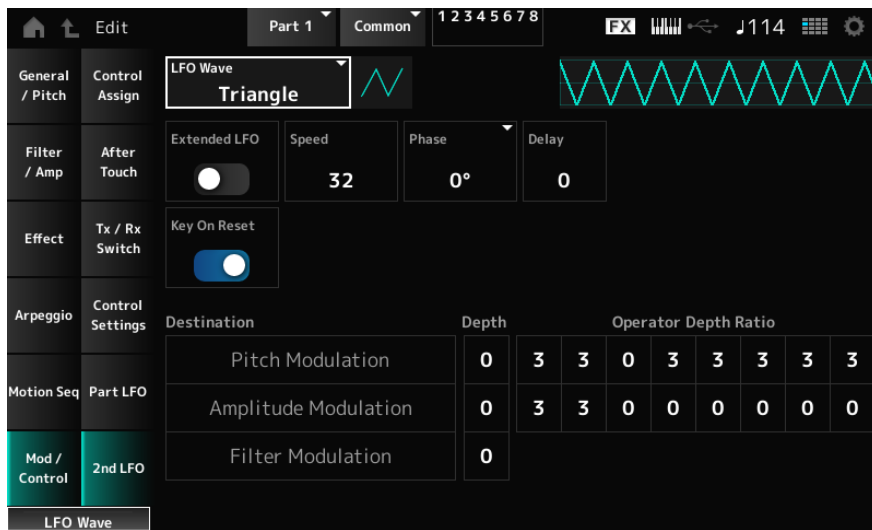

LFO Wave (2nd LFO Wave)

Selects the 2nd LFO.

Settings: Triangle, Saw Down, Saw Up, Square, Sine, S/H

NOTE

The Amplitude Modulation phase is shifted with Sine.

Extended LFO (2nd LFO Extended LFO)

Switches between the old set of Speed (2nd LFO Speed) settings (Off: 0–99) and a new set of settings with higher resolution (On: 0–415) for Speed (LFO Speed).

To maintain compatibility of data created with the old settings, set this parameter to Off.

Settings: Off, On

Speed (2nd LFO Speed)

Sets the speed of LFO Wave (2nd LFO Wave) changes.

Settings: 0–99 (When Extended LFO is set to Off), 0–415 (When Extended LFO is set to On)

Phase (2nd LFO Phase)

You can set the initial phase for the time the LFO Wave (2nd LFO Wave) is reset.

Settings: 0°, 90°, 180°, 270°

Delay (2nd LFO Delay Time)

Sets the time length for the 2nd LFO effect to fade in after you have released the key and the delay time set in Delay has elapsed.

Settings: 0–99

Key On Reset (2nd LFO Key On Reset)

Resets the oscillation of the 2nd LFO when a key is pressed.

Settings: Off, On

Pitch Modulation Depth (2nd LFO Pitch Modulation Depth)

This parameter creates a vibrato effect (cyclical changes to the pitch) by using the LFO Wave (2nd LFO Wave) and lets you specify the depth of filter modulation by the LFO.

Settings: 0–99

Pitch Modulation Operator Depth Ratio 1~8 (2nd LFO Pitch Modulation Depth Offset)

Sets the depth of the modulation by LFO signals set in Pitch Modulation Depth (2nd LFO Pitch Modulation Depth).

Settings: 0–7

Amplitude Modulation Depth (2nd LFO Amplitude Modulation Depth)

This parameter creates cyclical changes in the volume by using the LFO Wave (2nd LFO Wave) and lets you specify the depth of filter modulation by the LFO.

Settings: 0–99

Amplitude Modulation Operator Depth Ratio 1~8 (2nd LFO Amplitude Modulation Depth Offset)

Sets the depth of the modulation by LFO signals set in Amplitude Modulation Depth (2nd LFO Amplitude Modulation Depth).

Settings: 0–7

Filter Modulation Depth (2nd LFO Filter Modulation Depth)

This parameter creates cyclical changes to the filter cutoff frequency by using the LFO Wave (2nd LFO Wave) and lets you specify the depth of filter modulation by the LFO.

Settings: 0–99

Part Edit (FM-X) Operator Edit Screens

The Normal Part (FM-X) consists of eight Operators.

Part Edit (FM-X) includes Part Common Edit (for setting parameters for the entire Part) and Operator Edit (for setting parameters for individual operators).

Form/Freq

On the Form/Freq screen, you can set the waveform and frequency of the Operator.

Operation

[PERFORMANCE (HOME)] → [EDIT/↺] → Part selection → Operator selection → Form/Freq

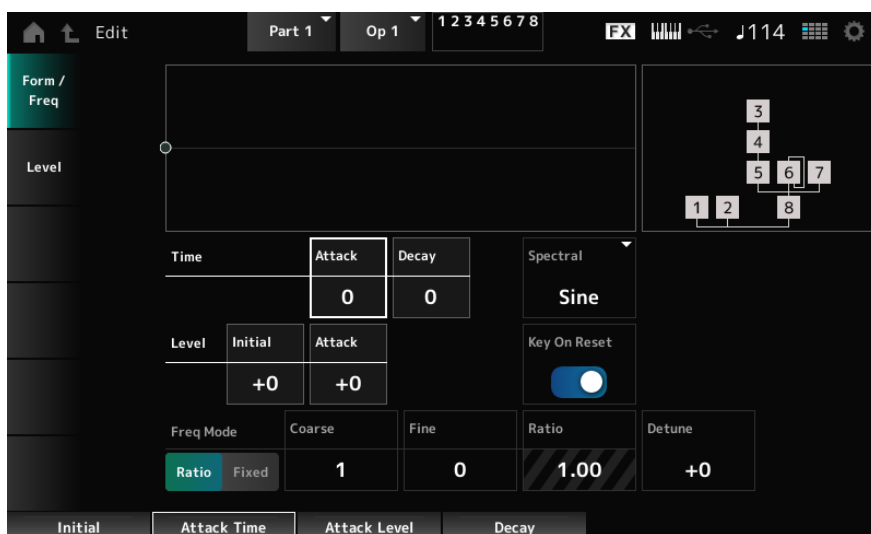

Attack Time (PEG Attack Time)

Sets the length of time it takes for the pitch to change from the moment you press a key on the keyboard until the time the pitch reaches the value set at Attack Level (PEG Attack Level).

Settings: 0–99

Decay Time (PEG Decay Time)

Sets the length of time it takes for the pitch to change from the value set at the Attack Level (PEG Attack Level) to the moment the PEG changes to the value 0.

Settings: 0–99

Initial Level (PEG Initial Level)

Sets the pitch for the moment you press the key.

Settings: –50–+0–+50

Attack Level (PEG Attack Level)

Sets the pitch to change from Initial Level (PEG Initial Level) after you have pressed a key.

Settings: -50-+0-+50

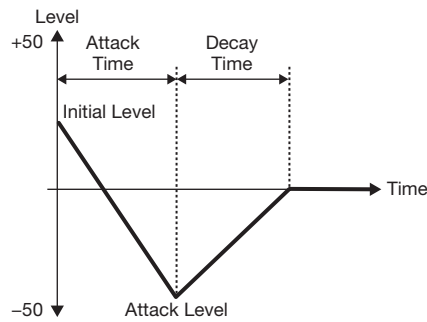

Spectral (Spectral Form)

Sets the waveform for the selected Operator.

Settings: Sine, All 1, All 2, Odd 1, Odd 2, Res 1, Res 2

Sine: Sine wave with no harmonic overtones

All 1: Wave with harmonic overtones in a wide Spectral range

All 2: Wave with harmonic overtones in a narrow Spectral range

Odd 1: Wave containing odd harmonics in a wide Spectral range

Odd 2: Wave containing odd harmonics in a narrow Spectral range

Res 1: Wave having a peak on a particular harmonic in a wide Spectral range

Res 2: Wave having a peak on a particular harmonic in a narrow Spectral range

Skirt (Spectral Skirt)

Sets the width of the transition band (skirt). The smaller the value, the narrower the skirt becomes to boost a particular harmonic.

This parameter is not available when the Spectral (Spectral Form) is set to Sine.

Settings: 0-7

Resonance (Spectral Resonance)

Sets the sensitivity of the resonance effect in Spectral.

The center frequency will be shifted to higher-order harmonics, so you can create the resonance effect or add special characteristics to the sound.

This parameter is available only when Spectral (Spectral Form) is set to Res 1 or Res 2.

Settings: 0–99

Sine is a simple waveform containing only the fundamental wave with no harmonics, while other waveforms contain harmonic overtones. Therefore, when you have set Form to a wave other than Sine, the parameters related to the harmonics and its “peak” values (formants) will be available.

Below are some specific parameters for controlling each wave explained in Spectral.

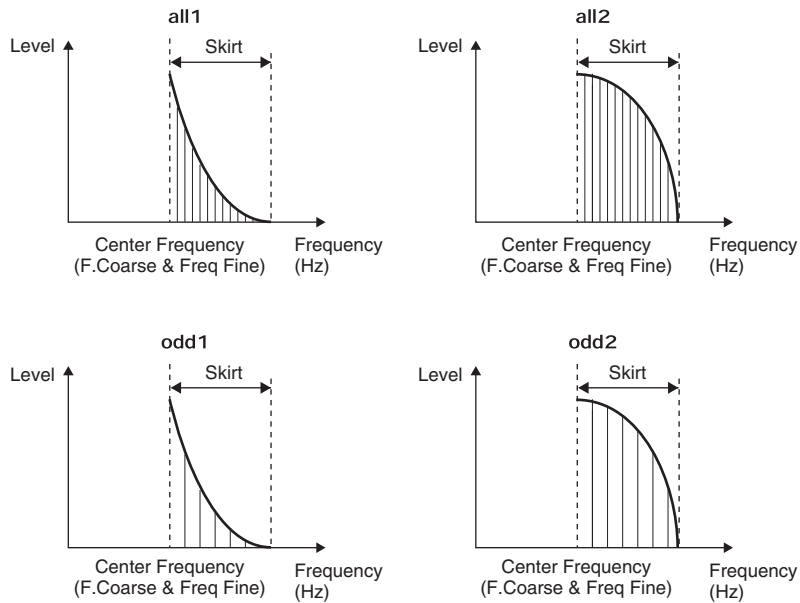

You can increase the number of harmonic overtones by setting a larger Skirt value to expand the spectrum range.

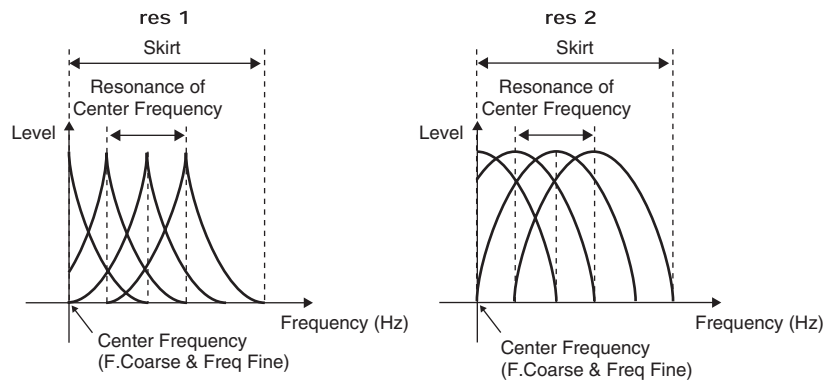

Setting a larger Resonance value will shift the center frequency to higher-order harmonics.

Resonance is set to 0: Shifts to the first harmonic.

Resonance is set to 99: Shifts to the 100th harmonic.

Key On Reset (Oscillator Key On Reset)

Resets the oscillation of the Oscillator when a key is pressed.

Settings: Off, On

Off: If you play a key without resetting the oscillator, the signal waveform will start regardless of the phase at that moment

Pitch/Vel (Pitch Velocity Sensitivity)

Sets how the pitch responds to Velocity or the strength of the keystroke.

This parameter is available only when Freq Mode (Oscillator Frequency Mode) is set to Fixed.

Settings: -7--+0--+7

Positive value: The faster the Velocity, the higher the pitch becomes

0: kept unchanged

Negative value: The faster the Velocity, the lower the pitch becomes

Freq Mode (Oscillator Frequency Mode)

Sets the output pitch of the Operator.

Settings: Ratio, Fixed

Ratio: Sets the output pitch according to the key

Fixed: Sets the pitch to the Coarse or Fine setting, regardless of the pitch of the key being pressed

Coarse (Coarse Tune)

Adjusts the output pitch of each Operator.

Settings: When Freq Mode is set to Ratio: 0–31, When Freq Mode is set to Fixed: 0–21

Fine (Fine Tune)

Finely adjusts the output pitch of each Operator.

Settings: When Freq Mode is set to Ratio: 0–99, When Freq Mode is set to Fixed: 0–127

Detune

Sets the output pitch of each Operator slightly higher or lower.

When the same value is set to Coarse (Coarse Tune) or Fine (Fine Tune), the Operator with the Detune setting will have slight pitch differences. As a result, you can create a warmer sound or chorusing effect.

Settings: -15--+0--+15

Pitch/Key (Pitch Key Follow Sensitivity)

Sets the difference in pitch between two adjacent keys. This parameter is available only when Freq Mode (Oscillator Frequency Mode) is set to Fixed.

Settings: 0–99

0: No pitch difference between the two adjacent keys and all keys are played at the pitch set in Coarse or Fine

99: Pitch difference between two adjacent keys is set to a semitone

Level

On the Level screen, you can set the general parameters for the Operator.

Operation

[PERFORMANCE (HOME)] → [EDIT/↺] → Part selection → Operator selection → Level



Hold Time (AEG Hold Time)

Sets the length of time it takes for the value to change from the moment you press a key on the keyboard until the time the value reaches the Rel (Hold) Level (AEG Release (Hold) Level).

Settings: 0–99

Attack Time (AEG Attack Time)

Sets the length of time it takes for the value to change from the moment you press a key on the keyboard until the time the value reaches the Attack Level (AEG Attack Level).

Settings: 0–99

Decay 1 Time (AEG Decay 1 Time)

Sets the length of time it takes for the value to change from the Attack Level (AEG Attack Level) to the Decay 1 Level (AEG Decay 1 Level).

Settings: 0–99

Decay 2 Time (AEG Decay 2 Time)

Sets the length of time it takes for the value to change from the Decay 1 Level (AEG Decay 1 Level) to the Decay 2 Level (AEG Decay 2 Level).

Settings: 0–99

Release Time (AEG Release Time)

Sets the length of time it takes for the value to change from the moment you have released the key until the time the value reaches the Rel (Hold) Level (AEG Release (Hold) Level).

Settings: 0–99

Attack Level (AEG Attack Level)

Sets the value to be changed to after pressing a key.

Settings: 0–99

Decay 1 Level (AEG Decay 1 Level)

Sets the next value to change from the Attack Level (AEG Attack Level).

Settings: 0–99

Decay 2 Level (AEG Decay 2 Level)

Sets the value that is maintained while the key is held down.

Settings: 0–99

Rel (Hold) Level (AEG Release (Hold) Level)

Sets the final value to reach after you have released the key.

Settings: 0–99

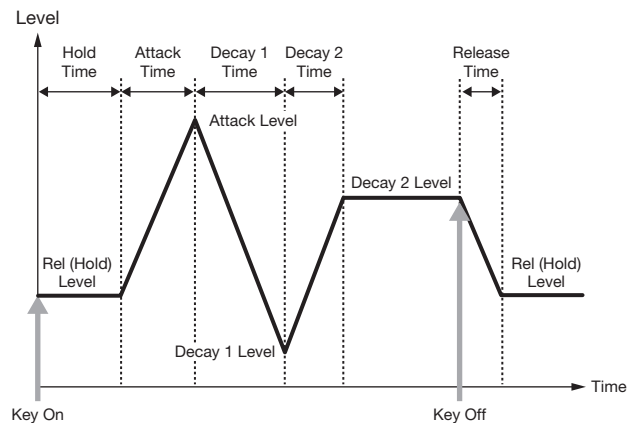

Level (Operator Level)

Sets the output level for the Operator.

Settings: 0–99

Level/Vel (Level Velocity Sensitivity)

Sets how the Level responds to Velocity or the strength of the keystroke.

Settings: -7+0+7

Positive value: The faster the Velocity, the louder the volume becomes

0: No change regardless of the velocity setting.

Negative value: The slower the Velocity, the louder the volume becomes

Time/Key (AEG Time Key Follow Sensitivity)

Sets how the speed of the level change in AEG responds to key position.

Settings: 0–7

Positive value: The lower the key played, the slower the AEG volume changes; the higher the key played, the faster the AEG volume changes.

0: No AEG volume change regardless of the key position

Break Point (Level Scaling Break Point)

Sets the note number for the Break Point of amplitude scaling.

Settings: A–1–C8

Lvl/Key Lo (Level Scaling Low Depth)

Lvl/Key Hi (Level Scaling High Depth)

Sets the steepness of the change curve.

Settings: 0–99

Curve Lo (Level Scaling Low Curve)

Curve Hi (Level Scaling High Curve)

Sets the change curve for amplitude scaling.

Settings: -Linear, -Exp, +Exp, +Linear

The keyboard is divided in two at the Break Point. Set Curve Lo for the steepness of the curve on the left side, and Lvl/Key Lo for the steepness of the curve on the right side. Similarly, set Curve Hi to select the curve for the right side, and Lvl/Key Hi to the steepness of the curve.

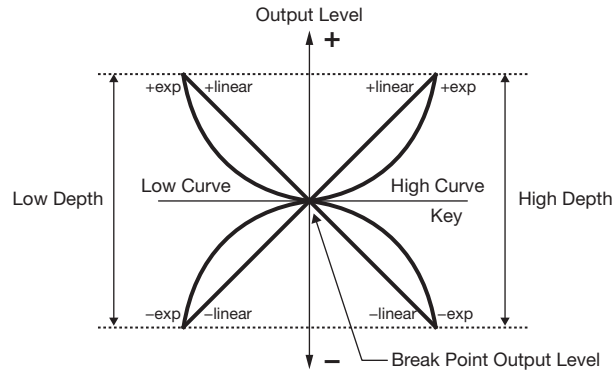

The key at the Break Point is the same as the output level set in the Level (Operator Level).

With the keys on the left side of the Break Point, the output level is corrected to the curve set in Curve Lo and Lvl/Key Lo.

With the keys on the right side of the Break Point, the output level is corrected to the curve set in Curve Hi and Lvl/Key Hi.

The output level of Exp curves changes exponentially, while the output level of Linear curves changes linearly. In either case, the farther away from the Break Point, the larger the changes to the output level.

Part Edit (AN-X) Part Common Edit Screens

The Normal Part (AN-X) consists of three Oscillators and Noise.

The Part Edit (AN-X) includes Part Common Edit for setting parameters for the entire Part, Oscillator Edit for setting parameters for each Oscillator, and Noise Edit for editing Noise.

General/Pitch

Part Settings

The same as General/Pitch → [Part Settings](#) on the Part Edit (AWM2) Part Common Edit screen.

Zone Settings

The same as General/Pitch → [Zone Settings](#) on the Part Edit (AWM2) Part Common Edit screen.

AN-X Settings

On the AN-X Settings screen, you can set the parameters that are specific to the AN-X sound engine.

Operation

[PERFORMANCE (HOME)] → Part Common selection → [EDIT/↺] → General/Pitch → AN-X Settings



Unison

Creates thickness by layering multiple sounds.

Settings: Off, 2, 4

Unison Detune

Sets how the pitch of the layered sound is to be shifted.

Settings: 0–15

Unison Spread

Sets how the layered sounds are spread in the stereo field.

Settings: 0–15

OSC Reset

Specifies how to reset the Oscillator.

Settings: Off, Phase, Tune, Full

Off: Does not reset.

Phase: Resets the phase of OSC 1–3 at key-on.

Tune: Makes the pitch of OSC 1–3 uniform.

Full: Enables both Phase and Tune simultaneously

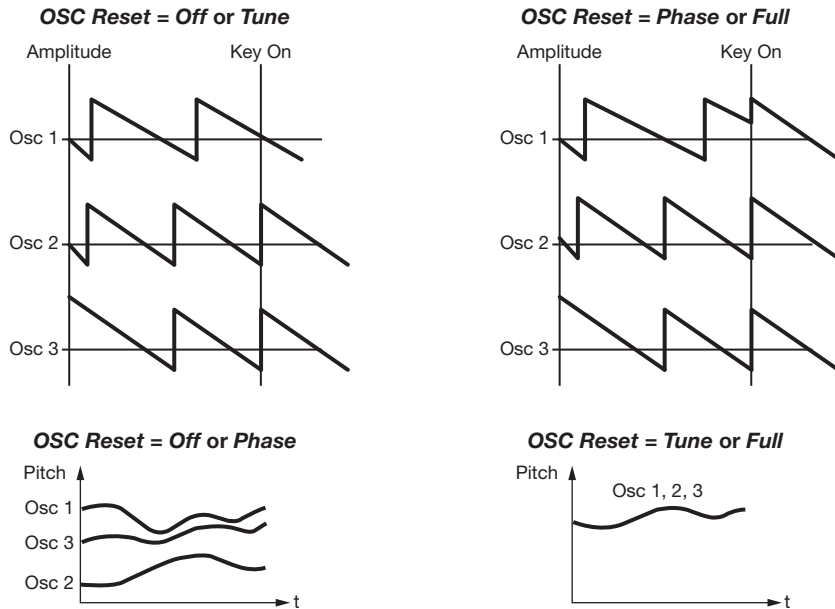

Voltage Drift

Specifies the pitch of the Oscillator and variation of Filter Cutoff. These variations are also affected by Ageing.

Settings: 0–127

0: No variation

64: Standard

127: Maximum variation

Ageing

Adjusts the frequency response as well as OSC Pitch, Filter Cutoff, and EG Time according to the virtual age of the instrument model.

Settings: –100 (old) – +100 (new)

■ Voltage Drift and Ageing

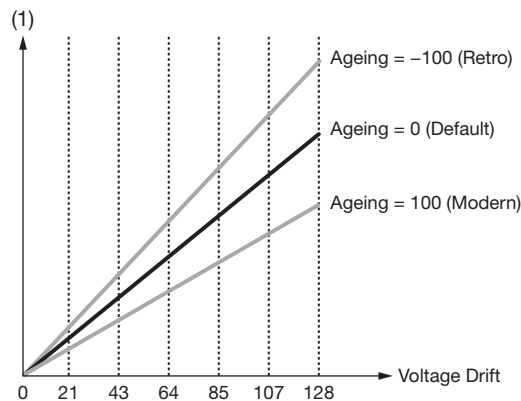

(1) Variations in Cutoff or Pitch

Filter Offset Cutoff (Filter Cutoff Frequency)

Changes the sound by setting the cutoff frequency of the filter. When the Low Pass Filter is selected, larger values here result in a brighter sound, and smaller values result in a darker sound.

This parameter is specified as an offset value to the filter cutoff frequency.

Settings: -64+0+63

Filter Offset Resonance (Filter Offset Resonance/Width)

Adds special characteristics to the sound by adjusting the signal level near the cutoff frequency.

This is specified as an offset value to the filter resonance.

Settings: -64+0+63

Filter Offset FEG Depth

Sets the depth range for the cutoff frequency change controlled by the FEG.

Settings: -64+0+63

Filter Type

The Filter Type screen will open.

Filter EG

The Filter EG screen will open.

AEG Offset Attack (AEG Attack Time)

Sets the length of time it takes for the volume to change from the moment you press a key on the keyboard to when it reaches the maximum.

Sets the offset value to Attack (Amplitude EG Attack Time).

Settings: -64+0+63

AEG Offset Decay (AEG Decay Time)

Sets the length of time it takes for the volume to change after it has reached the maximum.

Sets the offset value to Decay (Amplitude EG Decay Time).

Settings: -64+0+63

AEG Offset Sustain (AEG Sustain Level)

Sets the volume that is maintained after the decay time.

Sets the offset value to Sustain (Amplitude EG Sustain Level).

Settings: -64+0+63

AEG Offset Release (AEG Release Time)

Sets the length of time it takes for the sound to decay after you have released the key.

Sets the offset value to Release (Amplitude EG Release Time).

Settings: -64+0+63

Amp EG

The Amp EG screen will open.

Pitch

The screen here is the same as the one opened from General/Pitch → [Pitch](#) on the Part Edit (AWM2) Part Common Edit screen, except that Legato Slope (Portamento Legato Slope) is disabled.

Pitch EG

On the Pitch EG screen, you can set the Pitch Envelope Generator.

You can use it to set how the sound changes over time, starting from the moment you press a key on the keyboard to when the sound decays.

Operation

[PERFORMANCE (HOME)] → Part Common selection → [EDIT/↺] → General/Pitch → Pitch EG



Attack (Pitch EG Attack Time)

Sets the length of time it takes for the EG to change from the moment you press a key on the keyboard until it reaches the maximum.

Settings: 0–255

Decay (Pitch EG Decay Time)

Sets the length of time it takes for the EG to change from the maximum to the Sustain (Pitch EG Sustain Level).

Settings: 0–255

Sustain (Pitch EG Sustain Level)

Sets the Sustain Level.

Settings: 0–511

Release (Pitch EG Release Time)

Sets the length of time it takes for the EG to reach a value of 0 after you have released the key.

Settings: 0–255

Time/Vel (Pitch EG Time Velocity Sensitivity)

Sets how the velocity changes the EG over time.

Larger the value the faster the changes of EG over time when the keys are played with fast velocity.

Settings: –255–+0–+255

PEG Depth - Osc 1–3 (Oscillator 1–3 Pitch EG Depth)

Sets the maximum amount of pitch change for the EG (in cents). The further the depth is from the value 0, the wider the pitch change range becomes.

Settings: -4800 cent – +0 – +4800 cent

0: kept unchanged

Negative value: Pitch change is inverted.

PEG Depth/Vel - Osc 1–3 (Oscillator 1–3 Pitch EG Depth Velocity Sensitivity)

Sets how the depth range of the pitch change controlled by the PEG responds to Velocity or the strength of the keystroke.

Settings: -255 – +0 – +255

Positive value: Faster Velocity values widen the depth range of the pitch change controlled by the PEG, while slower values narrow the depth range

0: No PEG changes regardless of the velocity setting.

Negative value: Faster Velocity values narrow the depth range of the pitch change controlled by the PEG, while slower values widen the depth range

When the value is positive

Fast Velocity (the depth range in pitch change is wider)

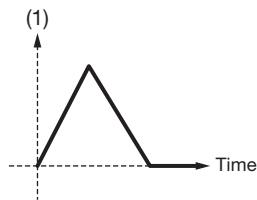

Slow Velocity (the depth range in pitch change is narrower)

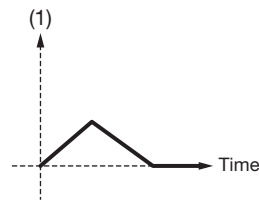

(1) Pitch Depth

Pitch LFO

On the Pitch LFO screen, you can set the Pitch LFO.

Operation

[PERFORMANCE (HOME)] → Part Common selection → [EDIT/↺] → General/Pitch → Pitch LFO

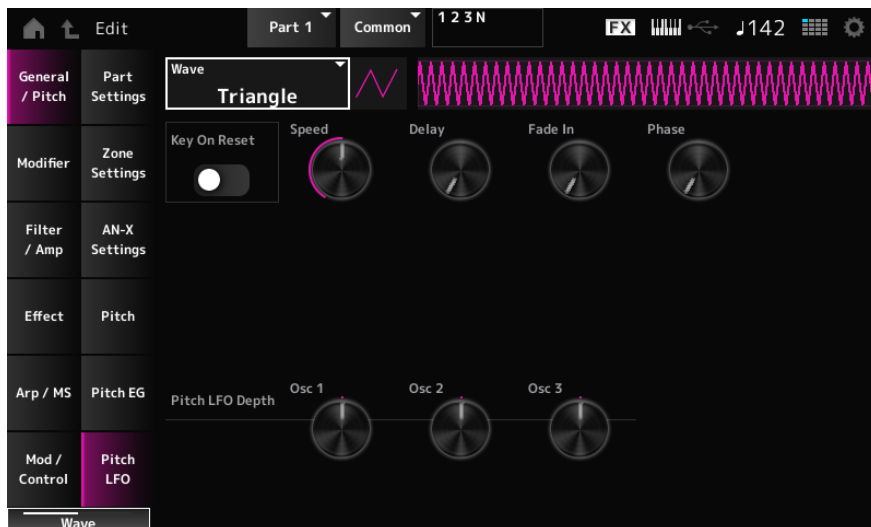

Wave (Pitch LFO Wave)

Selects the LFO Wave and sets the type of cyclical changes to the LFOs.

Settings: Saw, Square, Triangle, Sine, Random



Key On Reset (Pitch LFO Key On Reset)

Resets the phase of the LFO when a key is pressed.

Settings: Off, On

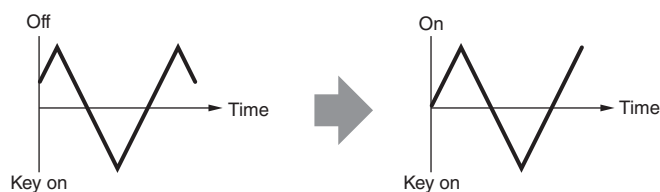

Speed (Pitch LFO Speed)

Sets the speed of LFO wave changes.

Settings: 0–415

Delay (Pitch LFO Decay Time)

Sets the delay time between the moment you press a key on the keyboard and the moment the LFO comes into effect.

Settings: 0–127

Fade In (Pitch LFO Fade In Time)

Sets the time length for the LFO effect to fade in after you have released the key and the delay time set in Delay has elapsed. The larger the value, the longer it takes for the LFO effect to reach the maximum.

Settings: 0–214

0: The LFO changes to the maximum value without any fade-ins.

When the value is small

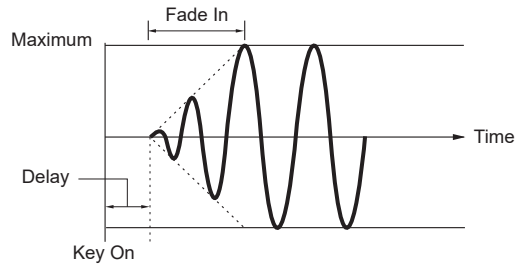

When the value is large

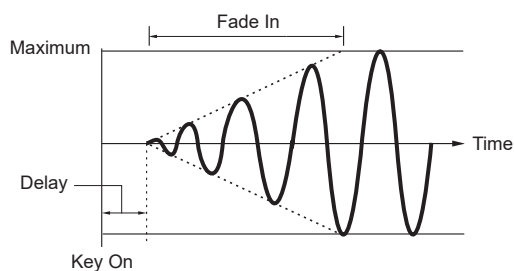

Phase (Pitch LFO Phase)

Sets the phase for resetting the wave when a key is pressed.

Settings: 0, 30, 45, 60, 90, 120, 135, 150, 180, 210, 225, 240, 270, 300, 315, 330(°)

Phase of the wave

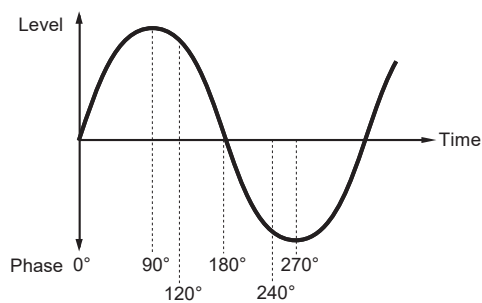

Pitch LFO Depth - Osc 1–3 (Oscillator 1–3 Pitch LFO Depth)

Sets the depth range of pitch change controlled by the LFO. The further the depth is from the value 0, the wider the pitch change range becomes.

Settings: –4800 cent – +0 – +4800 cent

0: kept unchanged

Negative value: Pitch change is inverted.

Modifier

Modifier is a function block for adding distortion to the signal output from the OSC block and for adding harmonics to the sound.

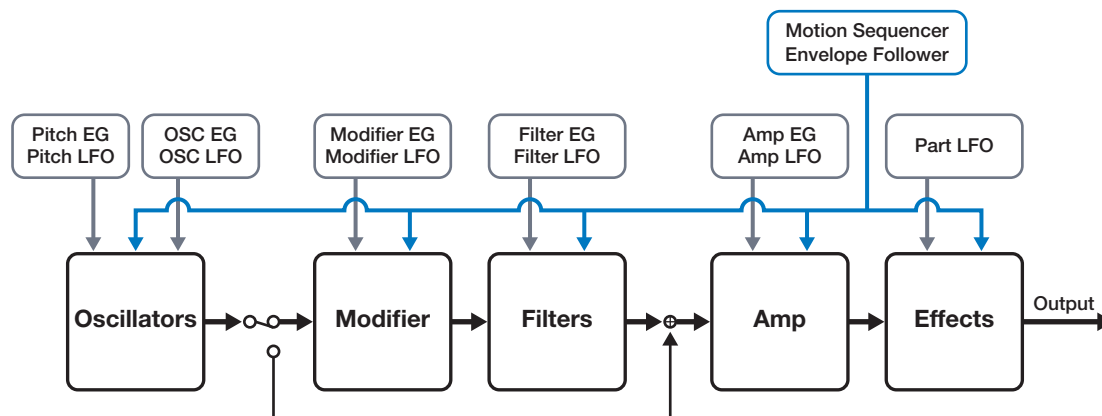

Wave Folder

Wave Folder is an effect created by folding waveforms according to the specified value. This effect lets you create smooth changes from delicate distortion to sonic destruction. With the AN-X sound engine, you can use this effect on each note independently.

Various controllers including EG, LFO, Velocity, and Polyphonic Aftertouch are available for controlling this effect in real-time.

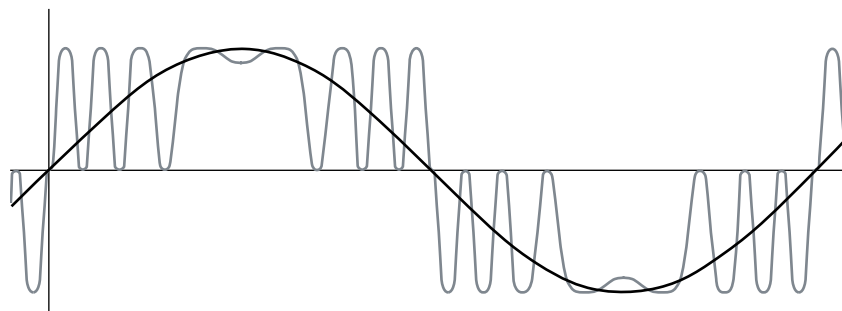

Operation

[PERFORMANCE (HOME)] → Part Common selection → [EDIT/↺] → Modifier → Wave Folder

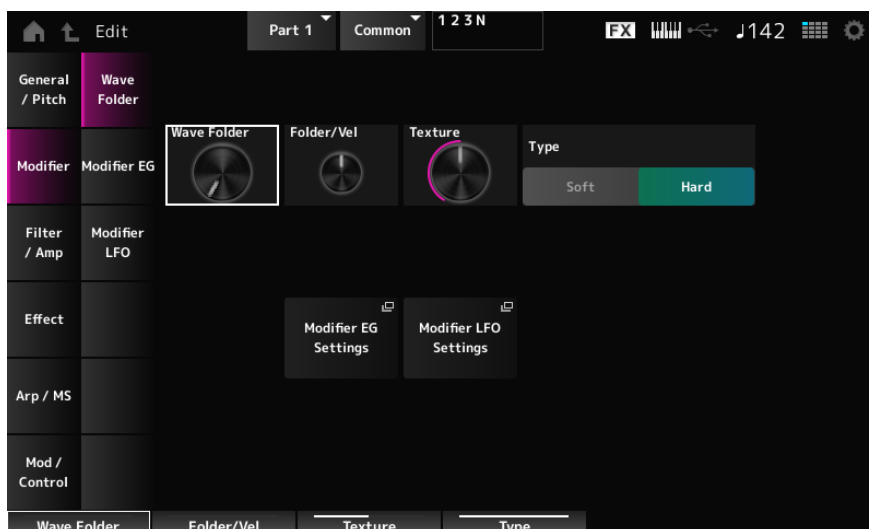

Wave Folder (Modifier Wave Folder)

Specifies the degree of wave folding.

Settings: 0–255

Folder/Vel (Modifier Wave Folder Velocity Sensitivity)

Sets how the Wave Folder responds to Velocity.

Settings: –255–+0–+255

Texture (Modifier Wave Folder Texture)

Changes the texture of the Wave Folder.

Settings: 0–255

Folder Type (Modifier Wave Folder Type)

Changes the Wave Folder type.

Settings: Soft, Hard

Modifier EG Settings

The Modifier EG screen will open.

Modifier LFO Settings

The Modifier LFO screen will open.

Modifier EG

On the Modifier EG screen, you can set the Envelope Generator for the Modifier.

Operation

[PERFORMANCE (HOME)] → Part Common selection → [EDIT/↺] → Modifier → Modifier EG

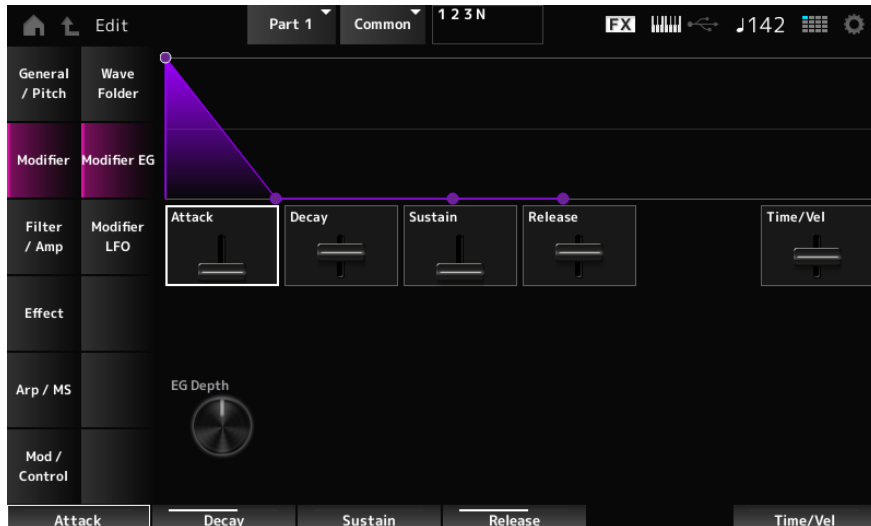

Attack (Modifier EG Attack Time)

Sets the length of time it takes for the EG to change from the moment you press a key on the keyboard until it reaches the maximum.

Settings: 0–255

Decay (Modifier EG Decay Time)

Sets the length of time it takes for the EG to change from the maximum to the Sustain (Modifier EG Sustain Level).

Settings: 0–255

Sustain (Modifier EG Sustain Level)

Sets the Sustain Level.

Settings: 0–511

Release (Modifier EG Release Time)

Sets the length of time it takes for the EG to reach a value of 0 after you have released the key.

Settings: 0–255

Time/Vel (Modifier EG Velocity Sensitivity)

Sets how the velocity changes the EG over time.

Larger the value the faster the changes of EG over time when the keys are played with fast velocity.

Settings: –255–+0–+255

EG Depth (Modifier Wave Folder EG Depth)

Sets how the Wave Folder responds to Modifier EG.

Settings: –127–+0–+127

Modifier LFO

On the Modifier LFO screen, you can set the Modifier LFO.

Operation

[PERFORMANCE (HOME)] → Part Common selection → [EDIT/↺] → Modifier → Modifier LFO

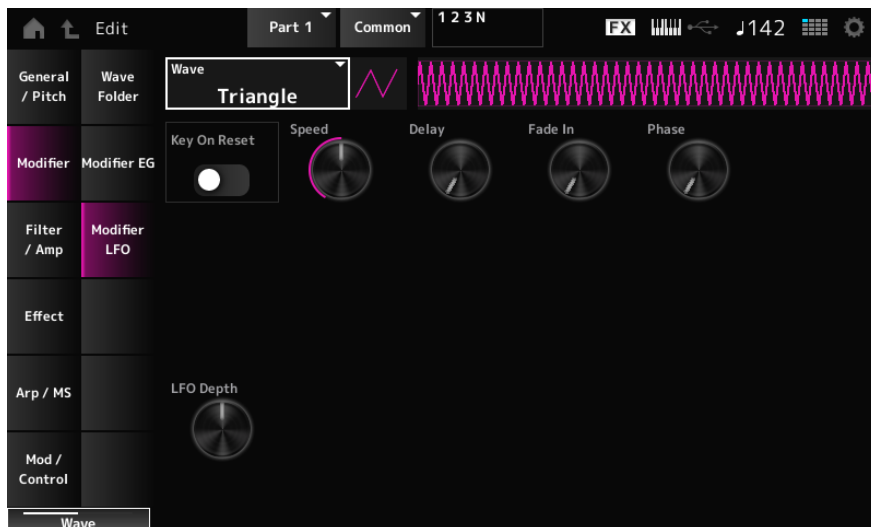

Wave (Modifier LFO Wave)

Selects the LFO Wave and sets the type of cyclical changes to the LFOs.

Settings: Saw, Square, Triangle, Sine, Random



Key On Reset (Modifier LFO Key On Reset)

Resets the phase of the LFO when a key is pressed.

Settings: Off, On

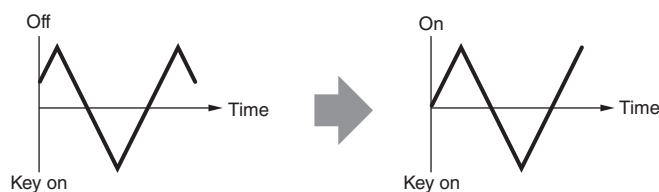

Speed (Modifier LFO Speed)

Sets the speed of LFO wave changes.

Settings: 0–415

Delay (Modifier LFO Decay Time)

Sets the delay time between the moment you press a key on the keyboard and the moment the LFO comes into effect.

Settings: 0–127

Fade In (Modifier LFO Fade In Time)

Sets the time length for the LFO effect to fade in after you have released the key and the delay time set in Delay has elapsed. The larger the value, the longer it takes for the LFO effect to reach the maximum.

Settings: 0–214

0: The LFO changes to the maximum value without any fade-ins.

When the value is small

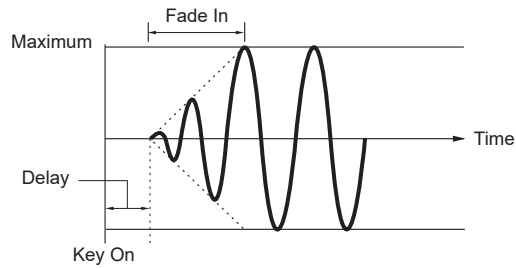

When the value is large

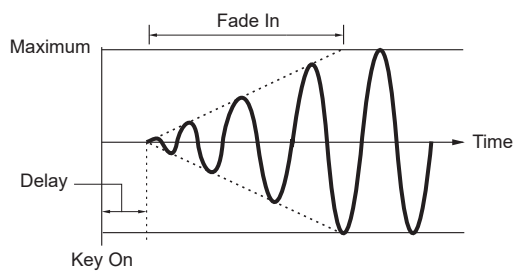

Phase (Modifier LFO Phase)

Sets the phase for resetting the wave when a key is pressed.

Settings: 0, 30, 45, 60, 90, 120, 135, 150, 180, 210, 225, 240, 270, 300, 315, 330(°)

Phase of the wave

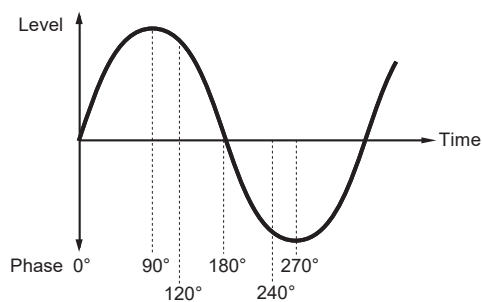

LFO Depth (Modifier Wave Folder LFO Depth)

Sets how the Wave Folder responds to Modifier LFO. The further the depth is from the value 0, the wider the pitch change range becomes.

Settings: -127–+0–+127

0: kept unchanged

Negative value: Pitch change is inverted.

Mixing

On the Mixing screen, you can set the output of each Oscillator while checking the signal flow diagram for the AN-X part.

Operation

[PERFORMANCE (HOME)] → Part Common selection → [EDIT/↺] → Filter/Amp → Mixing

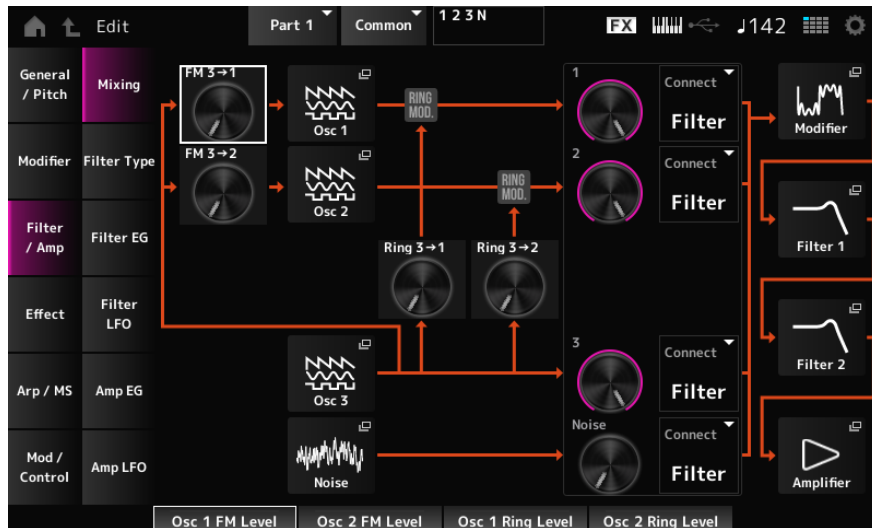

FM 3 → 1 (Oscillator 1 FM Level)

FM 3 → 2 (Oscillator 2 FM Level)

Sets how OSC3 modulates OSC1 and OSC2 by using frequency modulation (FM).

Settings: 0–255

Osc 1 (Oscillator 1)

Osc 2 (Oscillator 2)

Osc 3 (Oscillator 3)

Opens the OSC/Tune screen for Oscillator Edit.

Noise

The Noise screen appears.

Useful for creating various SFX sounds by using filters such as VCF and HPF on the noise signals.

Ring 3 → 1 (Oscillator 1 Ring Level)

Ring 3 → 2 (Oscillator 2 Ring Level)

Sets how the OSC3 modulates OSC1 and OSC2 by using Ring Modulation.

Settings: 0–255

1 (Oscillator 1 Out Level)

2 (Oscillator 2 Out Level)

3 (Oscillator 3 Out Level)

Noise (Noise Out Level)

1, 2, and 3 are for setting the Oscillator volume.

Noise is for adjusting the level of the signal output from the Noise Unit. You can control the level balance with other signals such as OSC 1, OSC 2, and Ring Modulator.

Settings: 0–511

- Connect 1 (Oscillator 1 Out Select)**
- Connect 2 (Oscillator 2 Out Select)**
- Connect 3 (Oscillator 3 Out Select)**
- Noise Connect (Noise Out Select)**

Sets the output destination for the Oscillators and Noise.

Settings: Filter, Amp

Modifier

Modifier → Wave Folder is displayed.

Filter 1

Filter 2

Filter/Amp → Filter Type is displayed.

Amplifier

Filter/Amp → Amp EG is displayed.

Filter Type

On the Filter Type screen, you can select the filter type.

The available parameters differ depending on the filter type you have selected here.

Operation

[PERFORMANCE (HOME)] → Part Common selection → [EDIT/↺] → Filter/Amp → Filter Type



Filter 1 Type

Filter 2 Type

Sets the filter.

The filters available for the AN-X are grouped into three types: LPF, HPF, and BPF.

Settings: Thru, LPF24, LPF18, LPF12, LPF6, HPF24, HPF18, HPF12, HPF6, BPF12, BPF6

- **LPF**

Cuts the signals above the value set in Cutoff Frequency. This is very popular and useful for producing classic synthesizer sounds.

The sound becomes brighter as you raise the Cutoff Frequency, since more signals are passed by the filter.

The sound becomes darker as you lower the Cutoff Frequency, since signals are cut or blocked by the filter.

You can produce a distinctive “peaky” sound by raising the Resonance or boosting the signal level near the Cutoff Frequency.

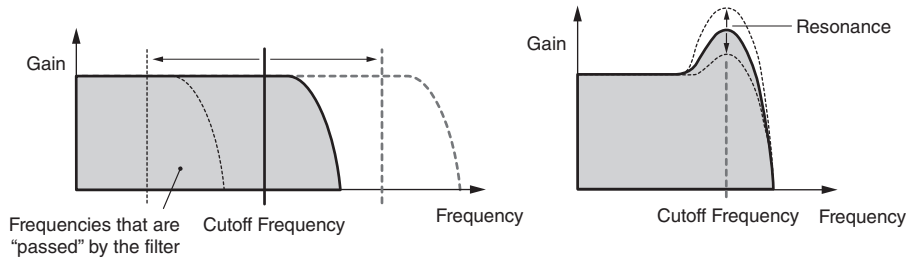

- LPF24:** -24 dB/oct
- LPF18:** -18 dB/oct
- LPF12:** -12 dB/oct
- LPF6:** -6 dB/oct

- **HPF**

A Filter Type that only passes signals above the Cutoff Frequency.

You can produce a distinctive “peaky” sound by raising the Resonance or boosting the signal level near the Cutoff Frequency.

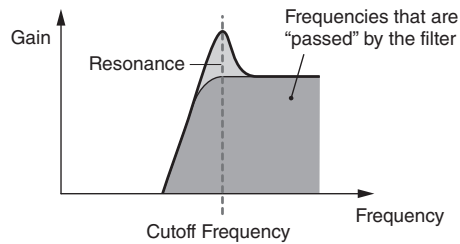

- HPF24:** -24 dB/oct
- HPF18:** -18 dB/oct
- HPF12:** -12 dB/oct
- HPF6:** -6dB/oct

- **BPF**

A Filter Type that only passes signals for a specific frequency band (Cutoff Frequency) and cuts all other signals.

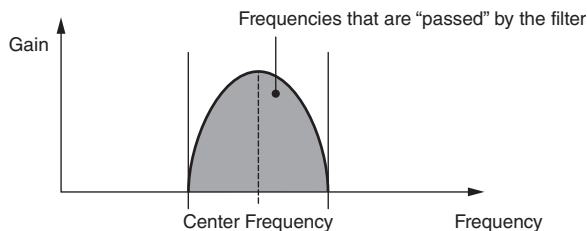

- BPF12:** -12dB/oct
- BPF6:** -6dB/oct

Cutoff (Filter Cutoff)

Sets the cutoff frequency. The frequency set here is used by the filter set in Filter Type.

Settings: 0–1023

Resonance (Filter Resonance)

Sets the size of the Resonance. This parameter may not be available depending on the Filter Type.

Settings: 0–255

Cutoff/Vel (Filter Cutoff Velocity Sensitivity)

Sets how Cutoff Frequency responds to Velocity or the strength of the keystroke.

Settings: –255–+0–+255

Positive value: The faster the Velocity, the higher the Cutoff Frequency value becomes

0: Cutoff frequency does not respond to the Velocity.

Negative value: The slower the Velocity, the higher the Cutoff Frequency value becomes

Resonance/Vel (Filter Resonance Velocity Sensitivity)

Sets how the resonance level responds to Velocity or the strength of the keystroke. This parameter may not be available depending on the Filter Type.

Settings: –255–+0–+255

Positive value: The higher the Velocity, the greater the Resonance becomes

Negative value: The lower the Velocity, the greater the Resonance becomes

0: Resonance value does not change in response to Velocity.

Cutoff/Key (Filter Cutoff Key Follow)

Sets how the cutoff frequency level of the filter responds to the key position. When the value is set to 1oct, both the pitch and the cutoff frequency change at the same rate.

Settings: Off, 1/3oct, 1/2oct, 2/3oct, 1oct, 2oct

Filter 1 Drive (Filter 1 Saturator Drive)

Filter 2 Drive (Filter 2 Saturator Drive)

Sets the amount of distortion controlled by the Saturator section of the filter.

Settings: 0.0 dB–60.0 dB (in units of 0.75 dB)

Filter 1 Drive/Vel (Filter 1 Saturator Drive Velocity Sensitivity)

Filter 2 Drive/Vel (Filter 2 Saturator Drive Velocity Sensitivity)

Sets how the Drive responds to Velocity.

Settings: –255–+0–+255

F1 Out Level (Filter 1 Out Level)

F2 Out Level (Filter 2 Out Level)

Sets the output level for the Filter.

Settings: –12.000 – +0.000 – +12.000 (dB) (in units of 0.375 dB)

Filter EG

On the Filter EG screen, you can set the Filter Envelope Generator (FEG).

The FEG lets you set the degree (or level) of changes to the Cutoff Frequency and how those changes evolve over time, starting from the moment you press a key on the keyboard to the moment the sound decays.

Operation

[PERFORMANCE (HOME)] → Part Common selection → [EDIT/↺] → Filter/Amp → Filter EG



Attack (Filter Cutoff EG Attack Time)

Sets the length of time it takes for the EG to change from the moment you press a key on the keyboard until it reaches the maximum.

Settings: 0–255

Decay (Filter Cutoff EG Decay Time)

Sets the length of time it takes for the EG to change from the maximum to the Sustain (Filter Cutoff EG Sustain Level).

Settings: 0–255

Sustain (Filter Cutoff EG Sustain Level)

Sets the Sustain Level.

Settings: 0–511

Release (Filter Cutoff EG Release Time)

Sets the length of time it takes for the EG to reach a value of 0 after you have released the key.

Settings: 0–255

Time/Vel (Filter Cutoff EG Time Velocity Sensitivity)

Sets how the Cutoff Frequency responds to Velocity or the strength of the keystroke.

Settings: –255–+0–+255

Positive value: The faster the velocity the faster the FEG changes

0: No changes regardless of the Velocity setting.

Negative value: Fast velocity values result in slower FEG changes, while slow velocity values result in faster FEG changes.

FEG Depth - Filter 1–2 (Filter 1–2 Cutoff EG Depth)

Sets the depth range for the cutoff frequency change controlled by the FEG in 50 cent units. The depth range of the Cutoff Frequency change becomes wider the further the setting is from a value of 0.

Settings: -9600 – +0 – +9600 (cent)

0: No changes to the cutoff frequency by the FEG

Negative value: Cutoff frequency changes are reversed.

FEG Depth/Vel - Filter 1–2 (Filter 1–2 Cutoff EG Depth Velocity Sensitivity)

Sets how the Cutoff Frequency controlled by the FEG responds to Velocity or the strength of the keystroke.

Settings: -255 – +0 – +255

Positive value: The faster the Velocity, the wider the depth range in Cutoff Frequency change by the FEG; the slower the Velocity, the narrower the depth range

0: Cutoff frequency does not respond to the Velocity.

Negative value: The faster the Velocity, the narrower the depth range in Cutoff Frequency change by the FEG; the slower the Velocity, the wider the depth range

Filter LFO

On the Filter LFO screen, you can set the Filter LFO.

Operation

[PERFORMANCE (HOME)] → Part Common selection → [EDIT/↺] → Filter/Amp → Filter LFO

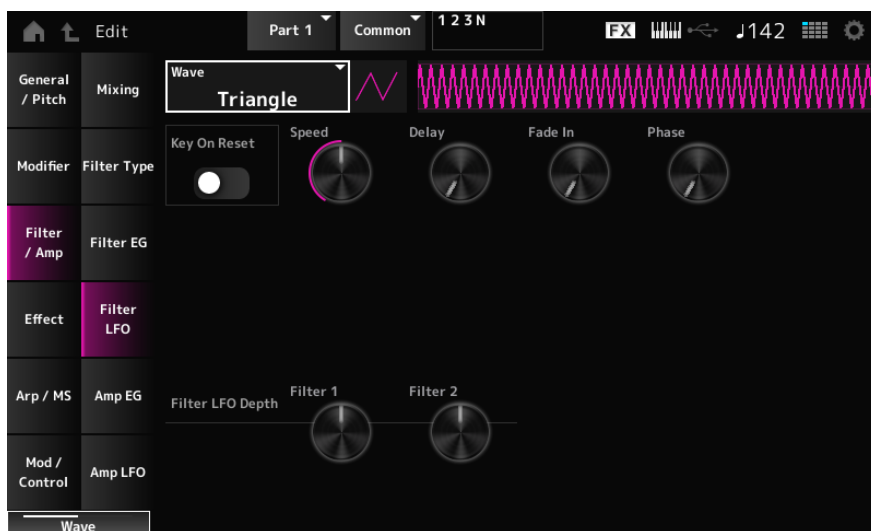

Wave (Filter Common Cutoff LFO Wave)

Selects an LFO wave. By using the wave you have selected here, you can create various types of modulation.

Settings: Saw, Square, Triangle, Sine, Random



Key On Reset (Filter Common Cutoff LFO Key On Reset)

Resets the oscillation of the LFO when a key is pressed.

Settings: Off, On

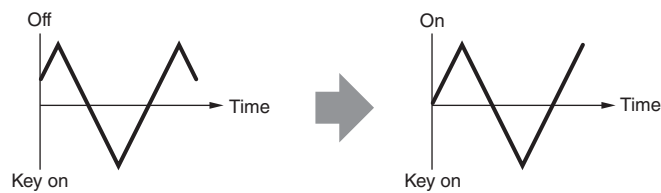

Speed (Filter Common Cutoff LFO Speed)

Sets the speed of LFO wave changes.

Settings: 0–415

Delay (Filter Common Cutoff LFO Decay Time)

Sets the delay time between the moment you press a key on the keyboard and the moment the LFO comes into effect. The larger the value, the longer the delay time for the LFO to come into effect.

Settings: 0–127

Fade In (Filter Common Cutoff LFO Fade In Time)

Sets the time length for the LFO effect to fade in after you have released the key and the delay time set in Delay has elapsed. The larger the value, the longer it takes for the LFO effect to reach the maximum.

Settings: 0–214

0: The LFO changes to the maximum value without any fade-ins.

When the value is small

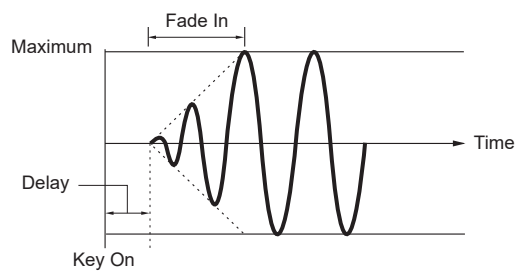

When the value is large

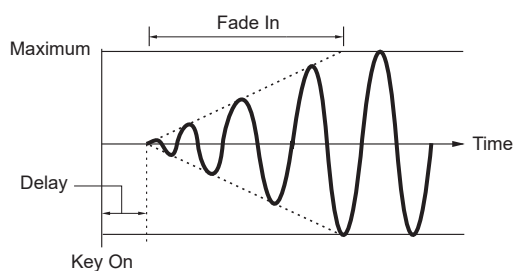

Phase (Modifier LFO Phase)

You can set the initial phase for the time the LFO wave is reset.

Settings: 0, 30, 45, 60, 90, 120, 135, 150, 180, 210, 225, 240, 270, 300, 315, 330(°)

Phase of the wave

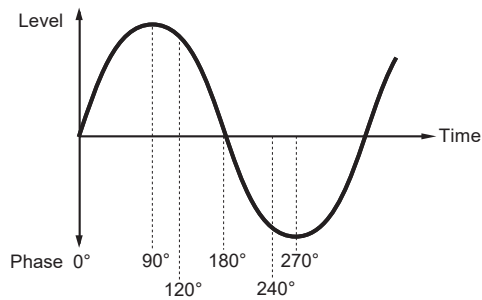

Filter LFO Depth - Filter 1–2 (Filter Cutoff LFO Depth)

Sets the depth of the LFO Wave control for Filter 1 and Filter 2 in 50 cent units.

Settings: -9600 – +0 – +9600 (cent)

Amp EG

On the Amp EG screen, you can set the AEG (Amplitude Envelope Generator).

By setting the Amp EG, you can set how the volume changes from the moment you press a key on the keyboard to when the sound decays.

Operation

[PERFORMANCE (HOME)] → Part Common selection → [EDIT/↶] → Filter/Amp → Amp EG



Attack (Amplitude EG Attack Time)

Sets the length of time it takes from the moment you press a key on the keyboard to when the Level (Amplitude Level) is reached.

Settings: 0–255

Decay (Amplitude EG Decay Time)

Sets the length of time it takes for the volume to change from the Level (Amplitude Level) to the Sustain (Amplitude EG Sustain Level).

Settings: 0–255

Sustain (Amplitude EG Sustain Level)

Sets the volume that is maintained while the key is held down.

Settings: 0–511

Release (Amplitude EG Release Time)

Sets the length of time it takes after you have release the key to when the sound decays.

Settings: 0–255

Time/Vel (Amplitude EG Time Velocity Sensitivity)

Sets the length of time it takes for volume changes in AEG to respond to Velocity or the strength of the keystroke.

Settings: –255–+0–+255

Positive value: The faster the velocity, the faster the AEG volume changes.

0: No changes regardless of the Velocity setting.

Negative value: Fast velocity values result in slower AEG volume changes, while slow velocity values result in faster AEG volume changes.

Level (Amplitude Level)

Sets the volume level of Amplitude.

Settings: 0–511

Level/Vel (Amplitude Level Velocity Sensitivity)

Sets how the Amplitude level responds to Velocity.

Settings: –255–+0–+255

Level/Key (Amplitude Level Key Follow)

Sets how the Amp Level responds to pitch.

When Amplitude Level Key is set to 127, the Amp Level goes down 6 dB as the pitch goes up one octave.

Settings: 0–127

Drive (Amplitude Saturator Drive)

Sets the amount of distortion controlled by the Saturator of the Amplitude section.

Settings: 0.0 dB–60.0 dB (in units of 0.75 dB)

Amp LFO

On the Amp LFO screen, you can set the Amplitude LFO.

Operation

[PERFORMANCE (HOME)] → Part Common selection → [EDIT/↺] → Filter/Amp → Amp LFO

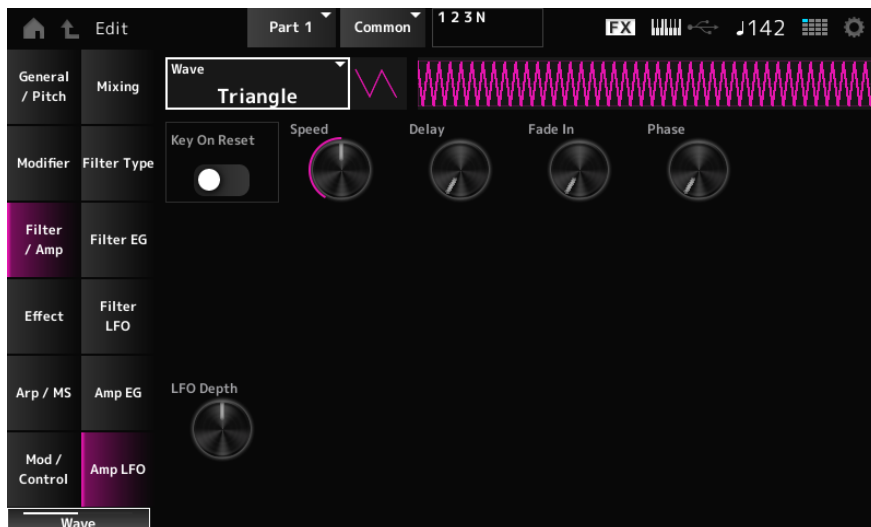

Wave (Amplitude LFO Wave)

Selects an LFO wave. By using the wave you have selected here, you can create various types of modulation.

Settings: Saw, Square, Triangle, Sine, Random



Key On Reset (Amplitude LFO Key On Reset)

Resets the oscillation of the LFO when a key is pressed.

Settings: Off, On

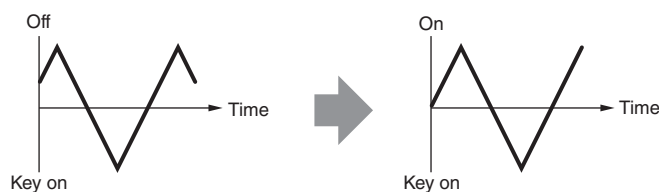

Speed (Amplitude LFO Speed)

Sets the speed of LFO wave changes.

Settings: 0–415

Delay (Amplitude LFO Decay Time)

Sets the delay time between the moment you press a key on the keyboard and the moment the LFO comes into effect. The larger the value, the longer the delay time for the LFO to come into effect.

Settings: 0–127

Fade In (Amplitude LFO Fade In Time)

Sets the time length for the LFO effect to fade in after you have released the key and the delay time set in Delay has elapsed. The larger the value, the longer it takes for the LFO effect to reach the maximum.

Settings: 0–214

0: The LFO changes to the maximum value without any fade-ins.

When the value is small

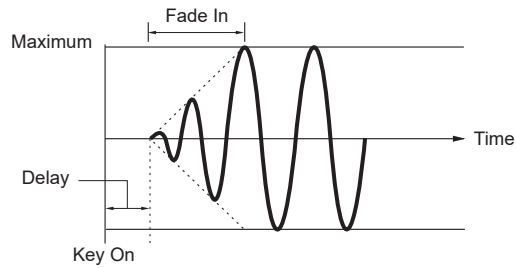

When the value is large

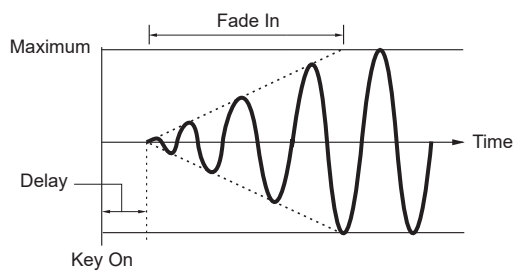

Phase (Amplitude LFO Phase)

You can set the initial phase for the time the LFO wave is reset.

Settings: 0, 30, 45, 60, 90, 120, 135, 150, 180, 210, 225, 240, 270, 300, 315, 330(°)

Phase of the wave

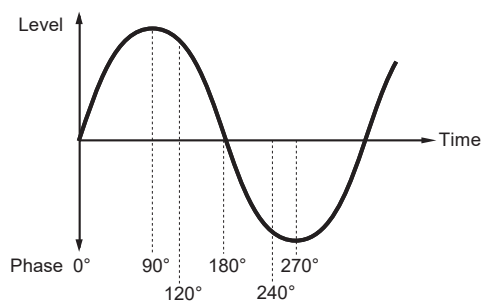

Depth (Amplitude Level LFO Depth)

Sets the depth range of volume changes controlled by the LFO.

Settings: -127+0+127

Effect

Routing

The screen here is almost the same as the one opened from Effect → [Routing](#) on the Part Edit (AWM2) Part Common Edit screen, with the exceptions listed below.

- No output setting for each Element
- Cannot select Parallel for Ins Connect

Ins A, Ins B

The same as Audio In → [Ins A, Ins B](#) on the Common Edit screen.

3-band EQ

The same as Effect → [3-band EQ](#) on the Part Edit (AWM2) Part Common Edit screen.

2-band EQ

The same as Effect → [2-band EQ](#) on the Part Edit (AWM2) Part Common Edit screen.

Ins Assign

The same as Effect → [Ins Assign](#) on the Part Edit (AWM2) Part Common Edit screen.

Arp Common

The same as Arpeggio → [Common](#) on the Part Edit (AWM2) Part Common Edit screen.

Individual

The same as Arpeggio → [Individual](#) on the Part Edit (AWM2) Part Common Edit screen.

Advanced

The same as Arpeggio → [Advanced](#) on the Part Edit (AWM2) Part Common Edit screen.

MS Common

The same as Motion Seq → [Common](#) on the Part Edit (AWM2) Part Common Edit screen.

Lane

The same as Motion Seq → [Lane](#) on the Part Edit (AWM2) Part Common Edit screen.

Control Assign

Other than the Destination setting, the same as Mod/Control → [Control Assign](#) on the Part Edit (AWM2) Part Common Edit screen.

Use the parameters shown below, instead of ElementSw and others.

Oscillator Sw (Oscillator Switch)

You can set the controller setting for each Oscillator on or off. This parameter is shown only when the selected Destination is related to Oscillators.

Usually, there are three switches shown, but when the Destination is set to OSC FM or OSC Ring, only two of them will be shown.

Settings: Off, On

Filter Sw

You can set the controller setting for each Filter on or off.

This parameter is shown only when the selected Destination is related to filters.

Settings: Off, On

After Touch

Other than the Destination setting, the same as Mod/Control → [After Touch](#) on the Part Edit (AWM2) Part Common Edit screen.

Tx/Rx Switch

The same as Mod/Control → [Tx/Rx Switch](#) on the Part Edit (AWM2) Part Common Edit screen.

Control Settings

The same as Mod/Control → [Control Settings](#) on the Part Edit (AWM2) Part Common Edit screen.

Part LFO

The screen here is the same as the one opened from Mod/Control → [Part LFO](#) on the Part Edit (AWM2) Part Common Edit screen, except that the only available Destination setting is Ins.

Part Edit (AN-X) Oscillator Edit Screens

The Normal Part (AN-X) consists of three Oscillators and Noise.

The Part Edit (AN-X) includes Part Common Edit for setting parameters for the entire Part, Oscillator Edit for setting parameters for each Oscillator, and Noise Edit for editing Noise.

OSC/Tune

On the OSC/Tune screen, you can set the general parameters for the Oscillator.

The modulation and wave shaping functions available on this screen are FM (Frequency Modulation), Ring Modulation, Oscillator Sync, Pulse Width, and Wave Shaper.

Operation

[PERFORMANCE (HOME)] → [EDIT/↺] → Part selection → Oscillator selection → OSC/Tune



Wave (Oscillator Wave)

Sets the waveform for the Oscillator.

Settings: Saw1, Saw2 (variation of Saw1 with thicker sound), Square, Triangle, Sine

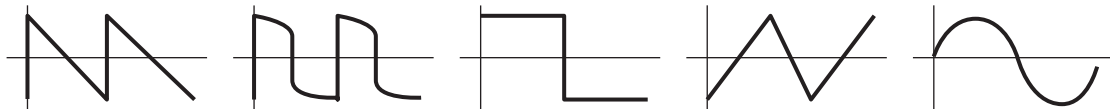

Out Level (Oscillator Out Level)

Sets the volume of the Oscillators.

Settings: 0–511

Out Level/Vel (Oscillator Out Level Velocity Sensitivity)

Sets how the Oscillator volume responds to Velocity.

Settings: -255–+0–+255

Invert (Oscillator Out Invert Enable)

Performs negative/positive inversion of the Oscillator output.

Settings: Off, On

Connect (Oscillator Out Select)

Sets the output destination for the Oscillators.

Settings: Filter, Amp

Octave (Oscillator Octave)

Sets the pitch of the Oscillator in octaves.

Settings: 64', 32', 16', 8', 4', 2', 1'

Pitch (Oscillator Pitch)

Finely adjusts the pitch of the Oscillator.

Settings: -1200 – +0 – +1200(cent)

■ **FM (Frequency Modulation)**

Modulates the frequency of the Oscillator by using another Oscillator.

FM Level (Oscillator FM Level)

Sets the level of the Frequency Modulation.

Settings: 0–255

FM Level/Vel (Oscillator FM Level Velocity Sensitivity)

Sets how Frequency Modulation responds to Velocity.

Settings: -255–+0–+255

■ **Ring Modulation**

By mixing two Oscillator signals, you can create a metallic inharmonic sound.

Ring Level (Oscillator Ring Level)

Sets the level of Ring Modulation.

Settings: 0–255

Ring Level/Vel (Oscillator Ring Level Velocity Sensitivity)

Sets how Ring Modulation responds to Velocity.

Settings: -255–+0–+255

■ **Oscillator Sync**

Oscillator Sync is a system that creates complex waves by forcing two Oscillators to synchronize.

The AN-X sound engine allows each Oscillator to set its synchronization timing, so you can use a single Oscillator for creating complex waveforms.

Sync Pitch (Oscillator Self Sync Pitch)

Sets the level of the Oscillator Sync in 25 cent units.

Settings: 0–4800 (cent)

Sync Pitch/Vel (Oscillator Self Sync Pitch Velocity Sensitivity)

Sets how Sync Pitch responds to Velocity.

Settings: -255–+0–+255

■ Pulse Width

Pulse Width is the ratio of the negative and positive parts of the Square wave.

When Pulse Width is set to a small value

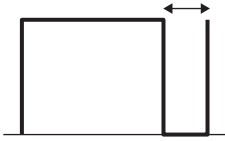

When Pulse Width is set to 50%

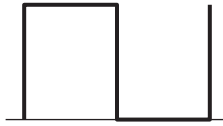

When Pulse Width is set to a large value

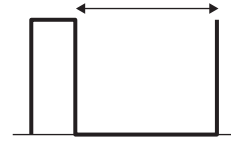

The AN-X sound engine lets you use Pulse Width not just on Square waves but also other waves.

Modulation of the LFO by using Pulse Width is called Pulse Width Modulation (PWM), which allows you to create a characteristic swirling sound.

With the AN-X sound engine, you can use PWM by using Osc EG and Osc LFO. you can specify the level of PWM on the Osc EG screen and Osc LFO screen.

Pulse Width (Oscillator Pulse Width)

Sets the Pulse Width of the wave.

Settings: 1.0%–50.0%–99.0%

PulseWidth/Vel (Oscillator Pulse Width Velocity Sensitivity)

Sets how Pulse Width responds to Velocity.

Settings: –255–+0–+255

■ Wave Shaper

Creates a characteristic distortion and changes to the harmonic content by changing the shape of the waveform.

Shaper (Oscillator Wave Shaper)

Sets the level of the Wave Shaper. By using Wave Shaper, the wave changes dynamically.

Settings: 0–255

Shaper/Vel (Oscillator Wave Shaper Velocity Sensitivity)

Sets how Wave Shaper responds to Velocity.

Settings: –255–+0–+255

Pitch EG Settings

General/Pitch → Pitch EG is shown on the Part Edit (AN-X) Part Common Edit screen.

Pitch LFO Settings

General/Pitch → Pitch LFO is shown on the Part Edit (AN-X) Part Common Edit screen.

OSC 1–3 EG Settings

The OSC EG screen appears.

OSC 1–3 LFO Settings

The OSC LFO screen appears.

OSC EG

On the OSC EG screen, you can set the Envelope Generator for the Oscillator.

You can set how the Sync, Pulse Width, and Wave Shaper change over time, starting from the moment you press a key on the keyboard to when the sound decays.

Operation

[PERFORMANCE (HOME)] → [EDIT/↶] → Part selection → Oscillator selection → OSC EG

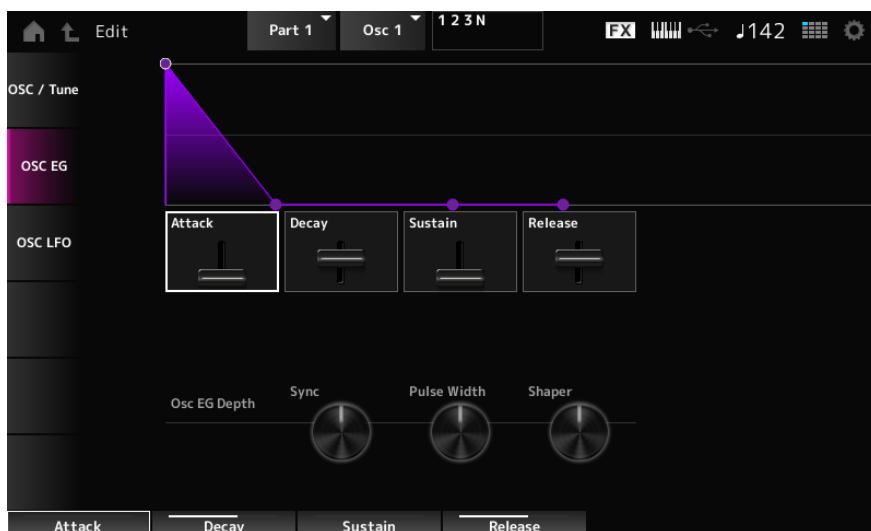

Attack (Oscillator EG Attack Time)

Sets the length of time it takes for the EG to change from the moment you press a key on the keyboard until it reaches the value set at the Attack Level.

Settings: 0–255

Decay (Oscillator EG Decay Time)

Sets the length of time it takes for the EG to change from the moment you press a key on the keyboard until it reaches the value set at the Decay Level.

Settings: 0–255

Sustain (Oscillator EG Sustain Level)

Sets the Sustain Level.

Settings: 0–511

Release (Oscillator EG Release Time)

Sets the length of time it takes for the EG to reach a value of 0 after you have released the key.

Settings: 0–255

Osc EG Depth Sync (Oscillator Self Sync EG Depth)

Sets how the Sync responds to Osc EG.

Settings: –4800 – +0 – +4800 (cent)

Osc EG Depth Pulse Width (Oscillator Pulse Width EG Depth)

Sets how the Pulse Width responds to Osc EG.

Settings: –127–+0–+127

Osc EG Depth Shaper (Oscillator Wave Shaper EG Depth)

Sets how the Shaper responds to Osc EG.

Settings: –127–+0–+127

OSC LFO

On the OSC LFO screen, you can set the Oscillator LFO.

Operation

[PERFORMANCE (HOME)] → [EDIT/↺] → Part selection → Oscillator selection → OSC LFO

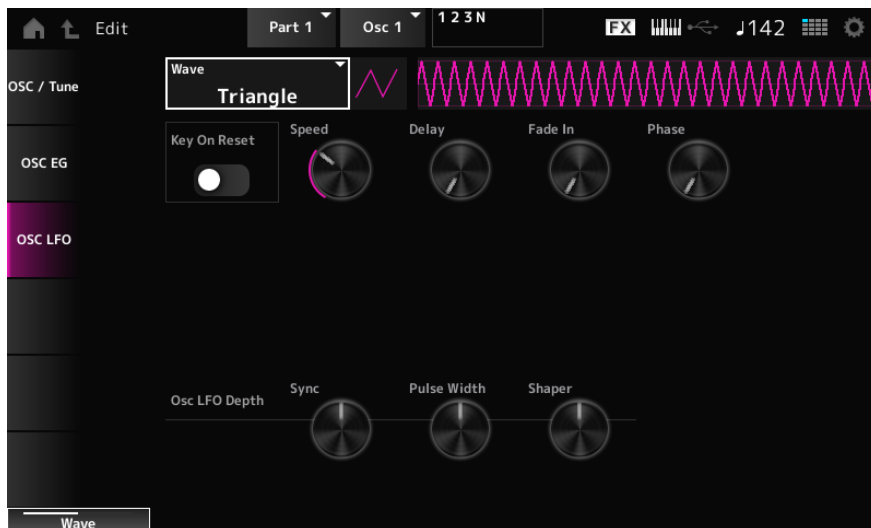

LFO Wave (Oscillator LFO Wave)

Selects an LFO wave. By using the wave you have selected here, you can create various types of modulation.

Settings: Saw, Square, Triangle, Sine, Random



Key On Reset (Oscillator LFO Key On Reset)

Resets the oscillation of the LFO when a key is pressed.

Settings: Off, On

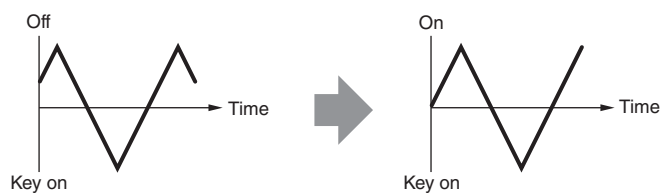

Speed (Oscillator LFO Speed)

Sets the speed of LFO wave changes.

Settings: 0–415

Delay (Oscillator LFO Delay Time)

Sets the delay time between the moment you press a key on the keyboard and the moment the LFO comes into effect.

Settings: 0–127

Fade In (Oscillator LFO Fade In Time)

Sets the time length for the LFO effect to fade in after you have released the key and the delay time set in Delay has elapsed.

Settings: 0–214

Oscillator LFO Phase

Sets the LFO phase for resetting the wave when a key is pressed.

Settings: 0, 30, 45, 60, 90, 120, 135, 150, 180, 210, 225, 240, 270, 300, 315, 330(°)

Osc LFO Depth Sync (Oscillator Self Sync LFO Depth)

Sets how the Sync responds to Osc LFO.

Settings: –4800 – +0 – +4800 (cent)

Osc LFO Depth Pulse Width (Oscillator Pulse Width LFO Depth)

Sets how the Pulse Width responds to Osc LFO.

Settings: –127→+0→+127

Osc LFO Depth Shaper (Oscillator Wave Shaper LFO Depth)

Sets how the Shaper responds to Osc LFO.

Settings: –127→+0→+127

Part Edit (AN-X) Noise Edit Screens

The Normal Part (AN-X) consists of three Oscillators and Noise.

The Part Edit (AN-X) includes Part Common Edit for setting parameters for the entire Part, Oscillator Edit for setting parameters for each Oscillator, and Noise Edit for editing Noise.

Noise

On the Noise screen, you can set the Noise Generator.

Operation

[PERFORMANCE (HOME)] → [EDIT/↺] → Part selection → Oscillator selection → Noise

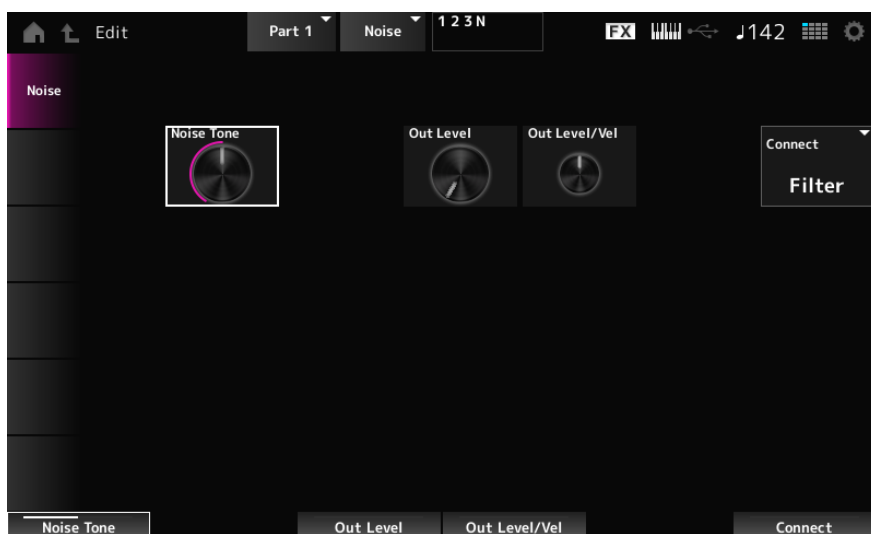

Noise Tone (Noise Generator Tone)

Sets the frequency response for the Noise.

Settings: 0–64–127

0–63: Cuts the treble

64: White noise

65–127: Cuts the bass

Out Level (Noise Generator Out Level)

Sets the volume of the Noise.

Settings: 0–511

Out Level/Vel (Noise Generator Out Level Velocity Sensitivity)

Sets how the Noise volume responds to Velocity.

Settings: –255→+0→+255

Connect (Noise Generator Out Select)

Sets the output destination for the Noise.

Settings: Filter, Amp

Category Search Screens

Category Search is a convenient function that allows you to quickly find a specific Performance, Part, Arpeggio, or Waveform you wish to use from a specified category.

Performance Category Search

On the Performance Category Search screen, you can search for and select Performances.

While the Category Search screen is shown, you can use the buttons on the top panel to change the Part Select or Mute settings.

Operation

Press the [CATEGORY] button

Tap the Performance name and select Category Search from the context menu

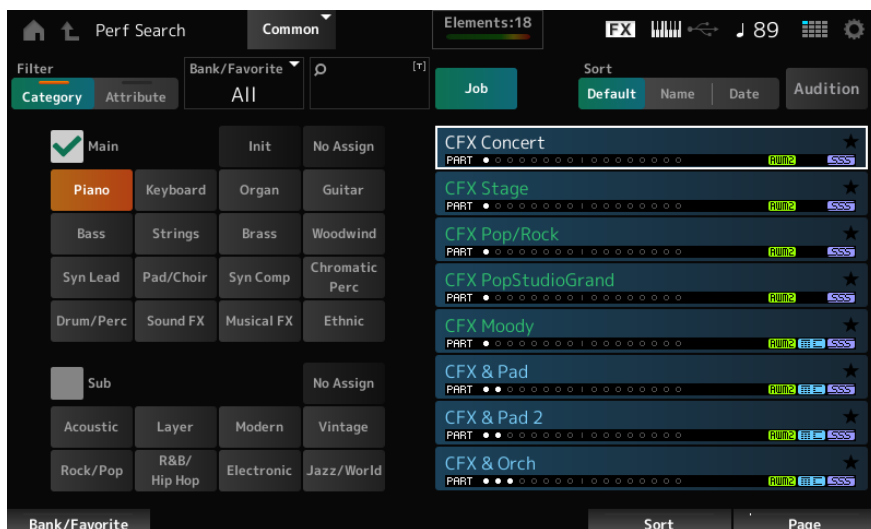

Filter

Select a filter to use in a search.

Settings: Category, Attribute

Main (Main Category)

Sub (Sub Category)

Filters by category.

By unchecking the Main or Sub checkbox, you can cancel filtering by category.

Settings: Refer to the Data List

Attribute

Filters by attribute.

By unchecking the Attribute checkbox, you can cancel filtering by attribute.

Settings: AWM2, FM-X, AN-X, MC, SSS, Smart Morph, Single, Multi, MOTIF XF, MONTAGE, MODX M OS V1.0

Bank/Favorite (Bank/Favorite Select)

Filters by bank or Favorites.

When Favorite is selected, only the Performances with Favorite Flags will appear in the list.

When the Category Search screen is shown, you can press the [CATEGORY] button to switch the Bank in the order of All → Favorite → Preset → User → Library name (when a Library file is loaded).

When you hold down the [CATEGORY] button, the selection will be reset to All.

Settings: All, Favorite, Preset, User, Library name (when a Library file is loaded)

Name Search

Allows you to enter certain characters included in the name for easy searching. You can use up to 20 alphanumeric characters.

Job

Calls up the Job menu.

- **Delete**
Deletes the selected content.
This parameter is available only when a Performance in the User Bank is selected.
- **Rename**
Changes the name of the selected content.
This parameter is available only when a Performance in the User Bank is selected.
- **Favorite All Clear**
Clears all Favorite Flags from the Performances.
This parameter is not available when there are no Performances with Favorite Flags.

Sort

Sets the sort order of the Performance list.

Settings: Default, Name, Date

Name: Sorts by name. The down arrow indicates that the list is arranged in ascending order (A to Z). The up arrow indicates that the list is arranged in descending order.

Date: Sorts by date the setting was stored. The down arrow indicates that the list is arranged in descending order (new to old). The up arrow indicates that the list is arranged in ascending order.

Audition

Sets the audition phrase playback on or off.

This parameter is not available when Audition Lock is set to On at [UTILITY] → Settings → Advanced.

Settings: Off, On

Performance list

Shows the Performance name, along with its active Parts, attributes, and Favorite Flag status.

Performance Merge

The Performance Merge screen allows you to assign multiple Parts of the selected Performance to empty Parts of another Performance. For example, you can layer a four-Part piano Performance and a two-part string Performance to create a rich six-part Performance.

Operation

[PERFORMANCE (HOME)] → Part selection (if the selected Part and all subsequent Parts are empty) → Tap [+]

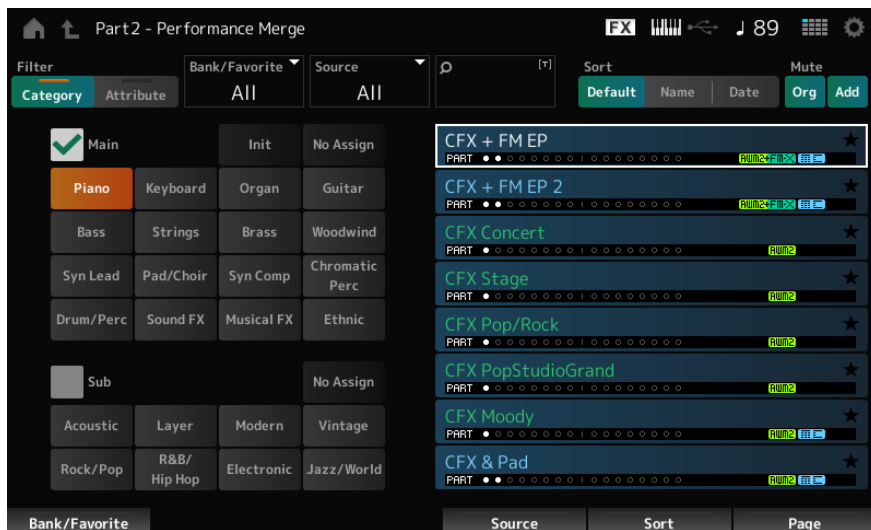

Source

When selecting a Performance, the sound of the Part specified here is assigned to the currently selected Part.

Settings: All, Part 1–16

All: All Parts in the selected Performance are assigned to empty Parts of the other selected Performance (as much as possible).

Part 1–16: Only the sound of the specified Part will be assigned to the other selected Part

Mute Org (Original Part Mute)

When this is set to Off, the Parts that were displayed before the Performance Merge screen was opened will be muted.

Settings: Off, On

Mute Add (Additional Part Mute)

When this is set to Off, the Parts added on the Performance Merge screen will be muted.

Settings: Off, On

Part Category Search

On the Part Category Search screen, you can search for and select Parts.

Operation

[SHIFT] + [CATEGORY]

(When selecting a Part to which a sound has already been assigned) Tap the Performance name and select Category Search from the context menu

(When selecting an empty Part to which a sound has already been assigned) Tap [+]

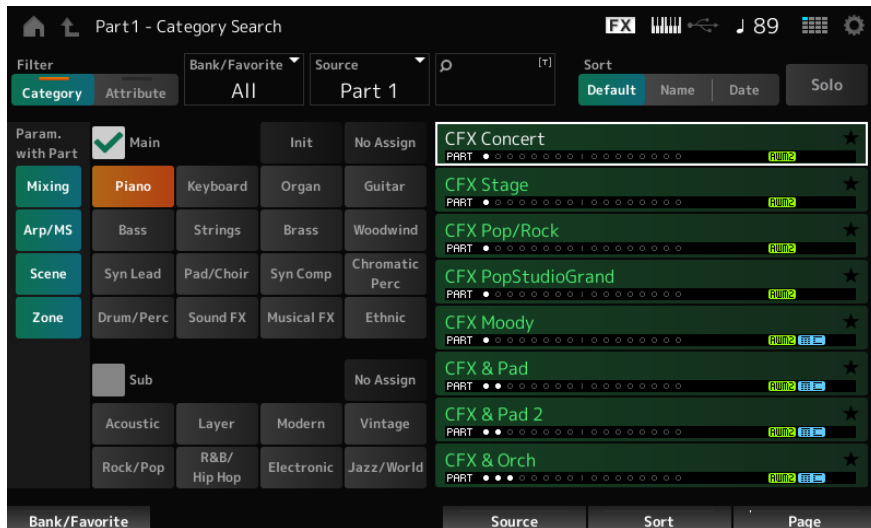

Source (Source Part)

When selecting a Performance, the sound of the Part specified here is assigned to the currently selected Part.

The initial setting is Part 1.

Settings: Part 1–16

Solo

Sets the Solo function on or off.

When this switch is turned On, the selected Part is set to solo.

Settings: Off, On

Param. with Part (Parameter with Part)

Loads a group of parameter values when a Performance is selected.

The parameter groups set to Off will retain their current settings even when a new Performance is selected.

Parameter groups: Mixing, Arp/MS, Scene, Zone

Settings: Off, On

Rhythm Pattern

On the Rhythm Pattern screen, you can search for and select Rhythm Patterns.

The Rhythm Pattern function allows you to instantly add a rhythm Part to the current Performance. Also, by combining Rhythm Patterns with envelope follower effects, you can further change the sound.

Operation

[SHIFT] + [SONG/PATTERN]

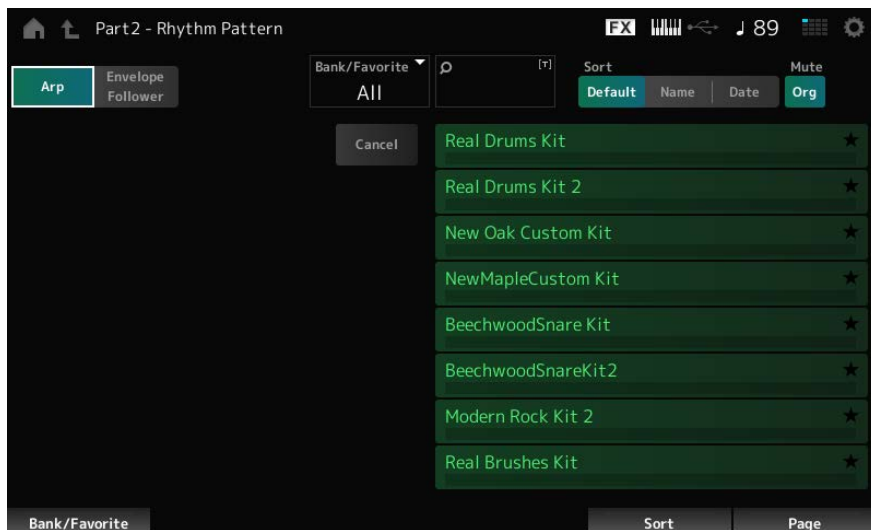

Arp (Arpeggio)

Envelope Follower

Selects Arpeggio display or Envelope Follower display.

Bank/Favorite (Bank/Favorite Select)

Filters by bank or Favorites.

When Favorite is selected, only the Rhythm Patterns with Favorite Flags will appear in the list.

Settings: All, Favorite, Preset, User, Library name (when a Library file is loaded)

Name Search

Allows you to enter certain characters included in the name for easy searching. You can use up to 20 alphanumeric characters.

Sort

Sets the sort order of the Rhythm Pattern list.

Settings: Default, Name, Date

Name: Sorts by name. The down arrow indicates that the list is arranged in ascending order (A to Z). The up arrow indicates that the list is arranged in descending order.

Date: Sorts by date the setting was stored. The down arrow indicates that the list is arranged in descending order (new to old). The up arrow indicates that the list is arranged in ascending order.

Mute Org (Original Part Mute)

When this is set to Off, the Parts that were displayed before the Rhythm Pattern screen was opened will be muted.

Settings: Off, On

Mute Add (Additional Part Mute)

When this is set to Off, the Parts added on the Rhythm Pattern screen will be muted.

Settings: Off, On

Rhythm Pattern list

Shows the Rhythm Pattern list.

Cancel

Cancels the operation.

■ When Arp is set to On

Frequently used parameters for Arpeggio settings are displayed on the left side of the screen.

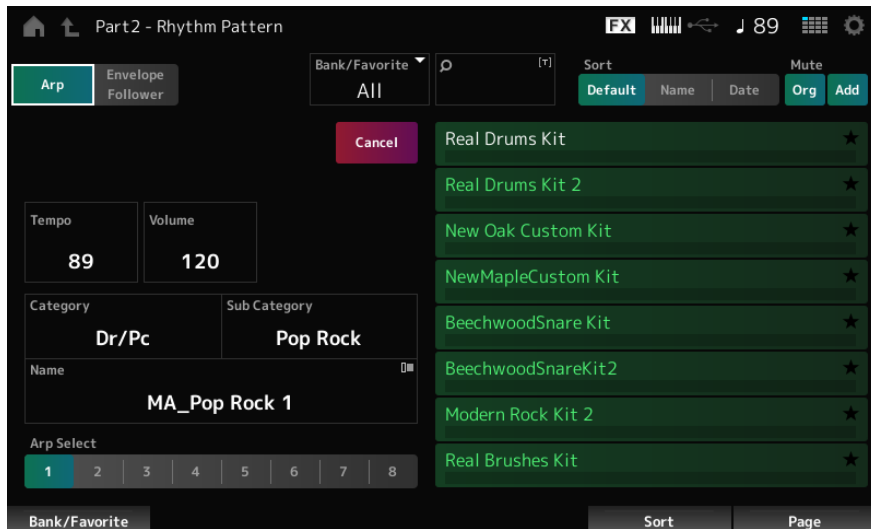

Tempo

Sets the tempo.

Settings: 5–300

Volume

Sets the volume of the Rhythm Pattern.

Settings: 0–127

Category (Arpeggio Main Category)

Sub Category (Arpeggio Sub Category)

Name

Shows the currently selected Arpeggio category, Sub category, and name.

By tapping on the name, you will see the context menu for Arpeggio Category Search and entering numbers.

Settings: Refer to the Data List

Arp Select (Arpeggio Select)

Selects the Arpeggio.

Settings: 1–8

■ When Envelope Follower is set to On

Frequently used parameters for the Envelope Follower settings are shown on the left side of the screen. This allows for quick editing of parameters frequently used for Rhythm Patterns. When you wish to change other parameters, use Edit to open the Envelope Follower Edit screen.

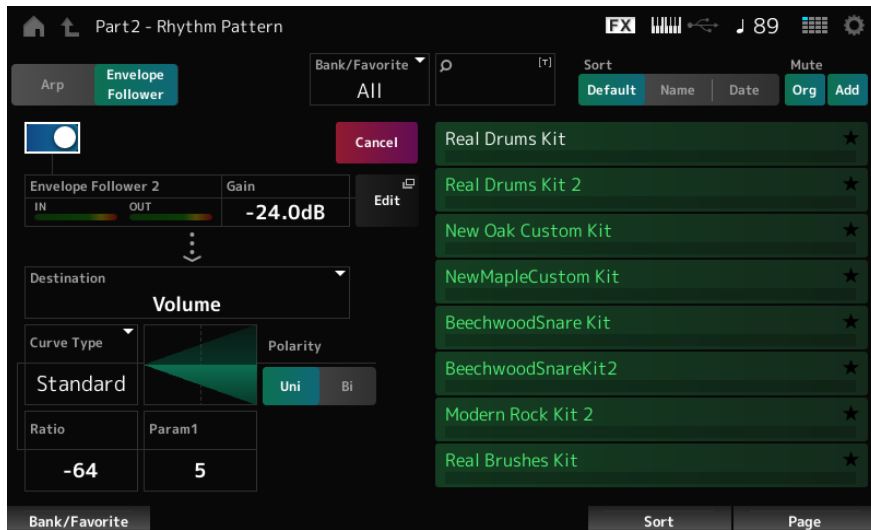

Quick Assign

Enables Envelope Follower.

Settings: Off, On

Gain (Envelope Follower Gain)

Sets the input gain for the input source.

Settings: -24.0dB – 0.0dB – 24.0dB

Destination

Sets the destination for the Envelope Follower.

Settings: Volume, Cutoff, Resonance, Pitch, Pan, Reverb Send, Variation Send, LFO Speed, LFO Depth 1, LFO Depth 2, LFO Depth 3

Curve Type

Polarity (Curve Polarity)

Ratio (Curve Ratio)

Param1 (Curve Parameter 1)

Param2 (Curve Parameter 2)

The same as the Control Assign screen.

Edit

The Envelope Follower Edit screen appears.

How to use the Rhythm Pattern function

Here, we will show an example of how to add the Rhythm Pattern 8Z Trance Basics 1 to the Performance Supertrance, and then modify the sound with the Envelope Follower.

First, add a rhythm part.

- 1. Select the performance to which you want to add a rhythm part.**
Select Supertrance.
- 2. Press [SHIFT]+[SONG/PATTERN] to open the Rhythm Pattern screen.**
When all of Parts 1–8 are being used, PartFull will be shown and no Rhythm Patterns can be added.
- 3. Tap the kit of the rhythm pattern you want to use from the rhythm pattern list.**
Tap 8Z Trance Basics 1.

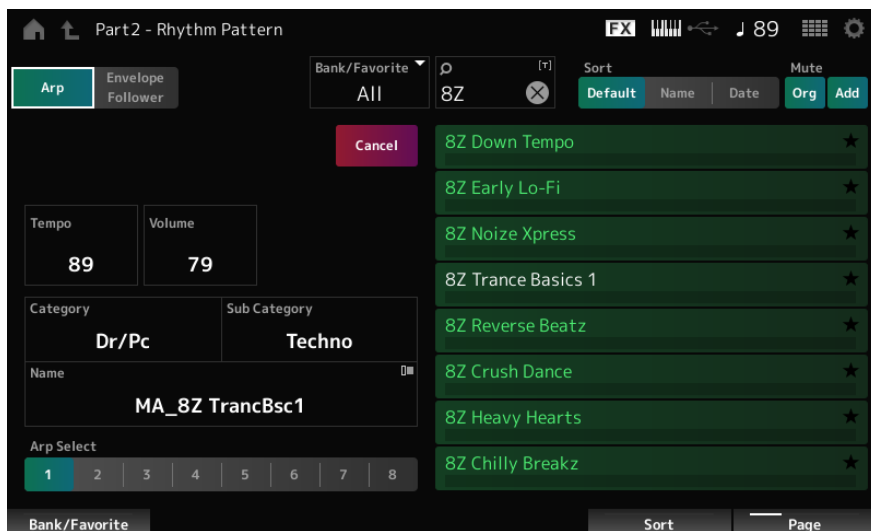

The rhythm Part has been added.

- 4. Press the key to play the rhythm.**
- 5. Press the [PERFORMANCE (HOME)] button or the [EXIT] button to confirm the Rhythm Pattern.**
The Rhythm Pattern screen will close.

NOTE

You can also confirm the selection by tapping the HOME icon (🏠).

- 6. To stop the Rhythm Pattern, press the [ARP] button or the [■] (Stop) button.**

Next, set the Envelope Follower. For information about the Envelope Follower, see "[Using the Envelope Follower.](#)"

- 7. Press [SHIFT]+[SONG/PATTERN] to open the Rhythm Pattern screen, and tap Envelope Follower.**
- 8. Set Quick Assign to On.**

You can play the keyboard to hear the sound with the Envelope Follower enabled.

9. The settings can be adjusted as necessary.

Here, in this example, set the Polarity to Bi, the Ratio to -64, and the Gain to -12.0 dB.

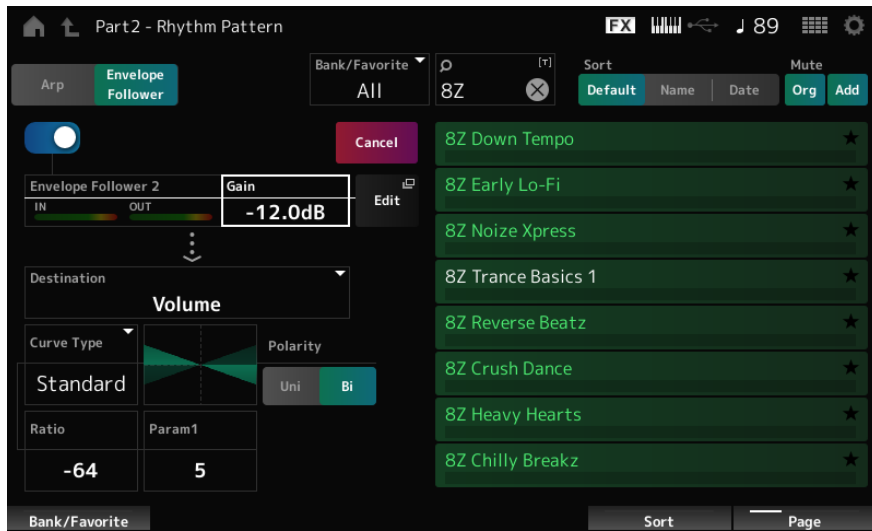

For finer adjustments, open the Envelope Follower Edit from Edit on the screen.

When you wish to change the Rhythm Pattern kit or Arpeggio type, press [SHIFT]+[SONG/PATTERN] to go back to the Rhythm Pattern screen. The Envelope Follower settings are retained even after the kit or the Arpeggio type has been changed.

Arp Category Search (Arpeggio Category Search)

On the Arp Category Search screen, you can search for and select Arpeggio types.

Operation

[PERFORMANCE (HOME)] → Part Common selection → [EDIT/↺] → Arpeggio → Individual → [CATEGORY]

[PERFORMANCE (HOME)] → Common selection → [EDIT/↺] → Arp / MS → Arp Overview → Part selection → [CATEGORY]

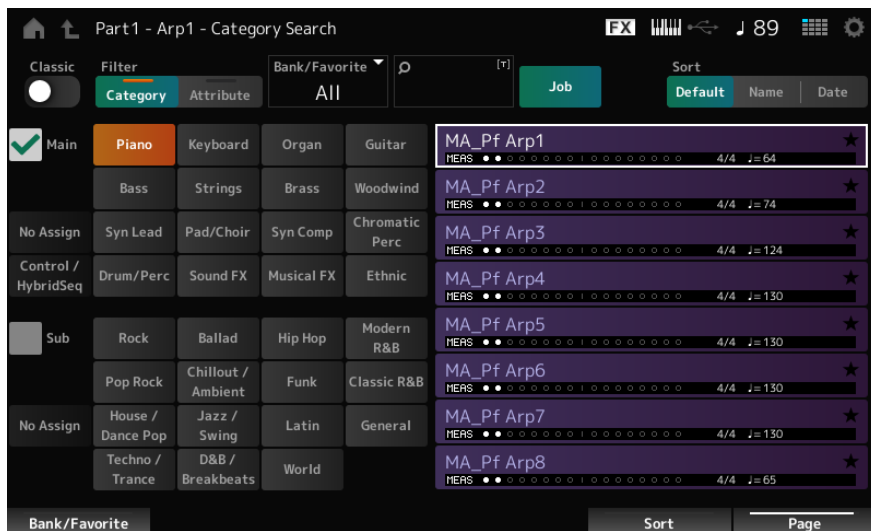

Classic (Classic Switch)

Sets the Classic view on or off.

In the Classic view, only common arpeggios are listed, and no filters are available for search.

Settings: Off, On

Main (Main Category)

Sub (Sub Category)

Filters by category.

By unchecking the Main or Sub checkbox, you can cancel filtering by category.

Settings: Refer to the Data List

Attribute

Filters by attribute.

By unchecking the Attribute checkbox, you can cancel filtering by attribute.

Settings: Note, Chord, Other, Intro, Main, Fill, Ending, AF, Accent, Random SFX, Mg, number of bars, time signature, tempo

Bank/Favorite (Bank/Favorite Select)

Filters by bank or Favorites.

When Favorite is selected, only the Arpeggio types with Favorite Flags will appear in the list.

Settings: All, Favorite, Preset, User, Library name (when a Library file is loaded)

Name Search

Allows you to enter certain characters included in the name for easy searching. You can use up to 20 alphanumeric characters.

Job

Calls up the Job menu.

- **Delete**
Deletes the selected content.
This parameter is available only when the Arpeggio in the User Bank is selected.
- **Rename**
Changes the name of the selected content.
This parameter is available only when the Arpeggio in the User Bank is selected.
- **Favorite All Clear**
Clears all Favorite Flags from the Arpeggios.
This parameter is not available when there are no Arpeggio types with Favorite Flags.

Sort

Sets the sort order of the Arpeggio type list.

Settings: Default, Name, Date

Name: Sorts by name. The down arrow indicates that the list is arranged in ascending order (A to Z). The up arrow indicates that the list is arranged in descending order.

Date: Sorts by date the setting was loaded. The down arrow indicates that the list is arranged in descending order (new to old). The up arrow indicates that the list is arranged in ascending order.

Arpeggio list

Shows the Arpeggio name, number of measures, time signature, recommended tempo, Attributes, and Favorite Flag status.

Waveform Search (Waveform Category Search)

On the Waveform Search screen, you can search for and select Waveforms.

Operation

Waveform-related screen → Part selection → Waveform selection → [CATEGORY]

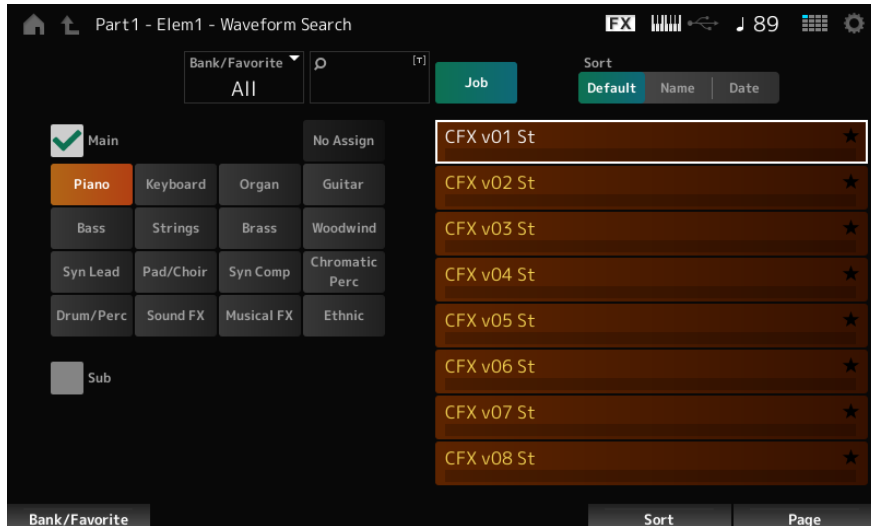

Bank/Favorite (Bank/Favorite Select)

Filters by bank or Favorites.

When Favorite is selected, only Waveforms with Favorite Flags will appear in the list.

Settings: All, Favorite, Preset, User, Library name (when a Library file is loaded)

Name Search

Allows you to enter certain characters included in the name for easy searching. You can use up to 20 alphanumeric characters.

Main (Main Category)

Sub (Sub Category)

Filters by category. By unchecking the Main or Sub checkbox, you can cancel filtering by category.

Settings: Refer to the Data List

Job

Calls up the Job menu.

- **Delete**
Deletes the selected content.
This parameter is available only when a Waveform in the User Bank is selected.
- **Rename**
Changes the name of the selected content.
This parameter is available only when a Waveform in the User Bank is selected.
- **Favorite All Clear**
Clears all Favorite Flags from the Waveforms.
This parameter is not available when there are no Waveforms with Favorite Flags.

Sort

Sets the sort order of the Waveform list.

Settings: Default, Name, Date

Name: Sorts by name. The down arrow indicates that the list is arranged in ascending order (A to Z). The up arrow indicates that the list is arranged in descending order.

Date: Sorts by date the setting was stored. The down arrow indicates that the list is arranged in descending order (new to old). The up arrow indicates that the list is arranged in ascending order.

Waveform list

Shows the Waveform list.

Live Set Screens

The Live Set function is a convenient way to instantaneously change among different Performances as you play songs on a setlist, for example.

Live Set

On the Live Set screen, you can call up a Performance.

When you press [SHIFT] + [EDIT/↻] while the User Bank is selected, a dialog will be shown and then you can copy or exchange pages or banks.

Operation

Press the [LIVE SET] button

Tap the LIVE SET icon (☰)

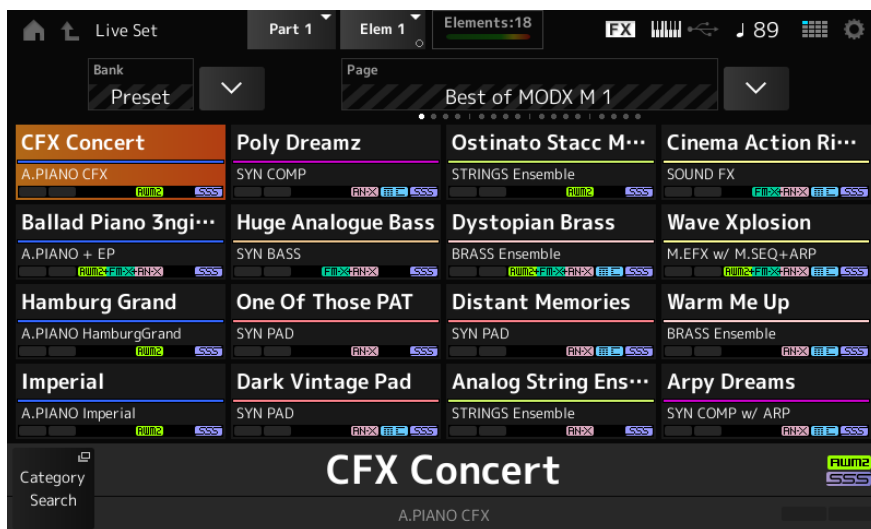

Bank (Bank Name)

Selects the Live Set bank.

Settings: Preset, User 1–8 (factory default settings), Library name (when a Library file is loaded)

Page

Selects the Live Set page.

Edit

The Live Set Edit screen appears.

Edit appears only when User Bank is selected.

Live Set Slot 1–16

Displays a list of Performances registered on the selected Live Set page.

Category Search

The Performance Category Search screen will open.

Current Performance Name

Shows the name of the Performance registered in the selected slot.

Current Slot Name

Shows the name of the selected slot.

When a Pattern, Song, or audio is assigned to a slot, the name of the Pattern or Song, or the audio file will be shown.

Performance Attribute

Shows the attribute(s) of the Performance registered in the selected slot.

On the Live Set screen, the PTN icon changes to PTN CHAIN when a Pattern with chain on is assigned to a slot.

PTN: Displayed for a slot to which a Pattern is assigned.

PTN CHAIN: Displayed for a slot to which a Pattern with chain on is assigned.

SONG: Displayed for a slot to which a Song is assigned.

AUDIO: Displayed for a slot to which audio is assigned.

Live Set Register

On the Live Set Register screen, you can register Performances to Live Set slots.

Operation

[SHIFT] + [LIVE SET]

While holding down the [SHIFT] button, tap the LIVE SET icon on the Navigation bar

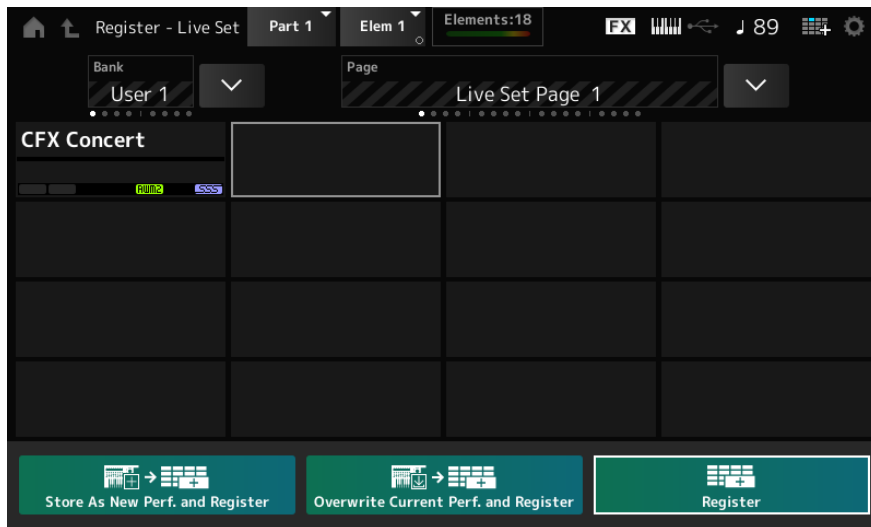

Store as New Perf. and Register (Store as New Performance and Register)

Stores the current Performance as a new Performance and registers it to the selected slot.

Jump to Data Utility

The Data Utility screen appears.

Overwrite Current Perf. and Register (Overwrite Current Performance and Register)

Stores the new Performance over the existing Performance and registers it to the selected slot.

Register

Registers Performances.

While holding down the [SHIFT] button, press Register to register a Performance by inserting it between slots.

Live Set Edit

On the Live Set Edit screen, you can edit Live Sets.

Only Live Sets in the User Bank can be edited.

Operation

[LIVE SET] → [EDIT/↺]

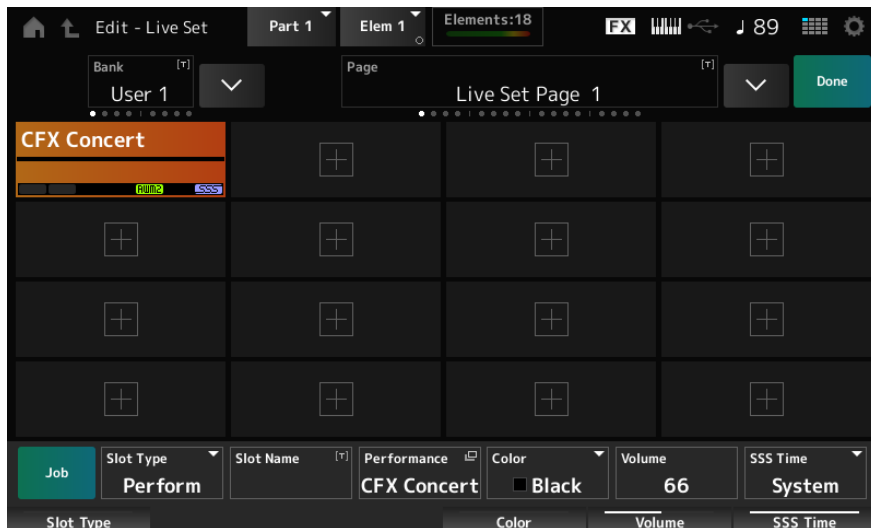

Bank (Bank Name)

Saves the selected Live Set bank under a new name. You can use up to 20 alphanumeric characters.

Page (Page Name)

Saves the selected Live Set page under a new name. You can use up to 20 alphanumeric characters.

Done

Tap to close the Live Set Edit and show the Live Set screen.

Live Set Slot 1–16

Displays a list of Performances registered to the selected Live Set.

[+] (Add)

Tap to register the selected Performance to that slot.

Job

Calls up the Job menu.

- **Copy**

Turns the copy function on.

You can copy settings by selecting a slot to copy from, tapping Copy, and then selecting the slot to copy to.
Settings: Off, On

- **Exchange**

Turns the exchange function on.

You can exchange settings by selecting the first slot, tapping Exchange, and then selecting the second slot.
Settings: Off, On

- **Delete**

Select the slot, and then tap Delete to delete any registered Performances and other settings from the slot.

- **Delete & Move**

Select the slot, and then tap Delete & Move to delete any registered Performances and other settings from the slot and move the subsequent slots up.

Slot Type

Selects the slot type.

Settings: Perform, Song, Audio, Pattern

Perform: Registers only the Performance to the slot

Song: Registers the Performance and Song to the slot

Audio: Registers the Performance and audio file to the slot

Pattern: Registers the Performance and Pattern to the slot

Slot Name

Song Name

Audio Name

Pattern Name

Shows the Slot Name when the Slot Type is Perform.

Tapping on the name calls up the onscreen keyboard, allowing you to enter a name for the current slot. You can use up to 20 alphanumeric characters.

When the Slot Type is Pattern, the Pattern Name is displayed; when it is Song, the Song Name is displayed; and when it is Audio, the Audio Name is displayed. The registered Pattern, Song or Audio will be shown. When you tap on the name, the Utility Load screen appears. Then you can select the Pattern, Song, or Audio to register.

Performance (Performance Name)

Shows the name of the Performance registered to the selected slot.

Tap to display the Performance Category Search screen.

Color

Sets the color for the selected slot.

Settings: Black, Red, Yellow, Green, Blue, Azure, Pink, Orange, Purple, Sakura, Cream, Lime, Aqua, Beige, Mint, Lilac

Volume

Sets the volume of the Performance registered in the selected slot.

SSS Time

Adjusts the SSS Time of the selected slot. If you set the SSS Time, even if you change the Performance while playing, if the sound being played is set to Note Off, the sound will fade out after the set time.

Settings: 0.0sec – 30sec, Hold, System

Playing back the Pattern, Song, or Audio file from the Live Set screen

Operation

[LIVE SET] (or tap the LIVE SET icon on the top panel) → User Bank selection → Slot selection → [▶] (Play) button

NOTE

- Performance and slot cannot be changed while the Pattern or Song is being played back. If you attempt to change them, an error message will appear.
- When you press the [▶] (Play) button while the Pattern, Song, or Audio file is played back, the Pattern, Song, or Audio file playback screen will open.

Utility Screens

The Utility screen is used for setting common items for the entire instrument.

Settings

Sound

The Sound screen is used for setting the sound output from the instrument.

Operation

[UTILITY] → Settings → Sound

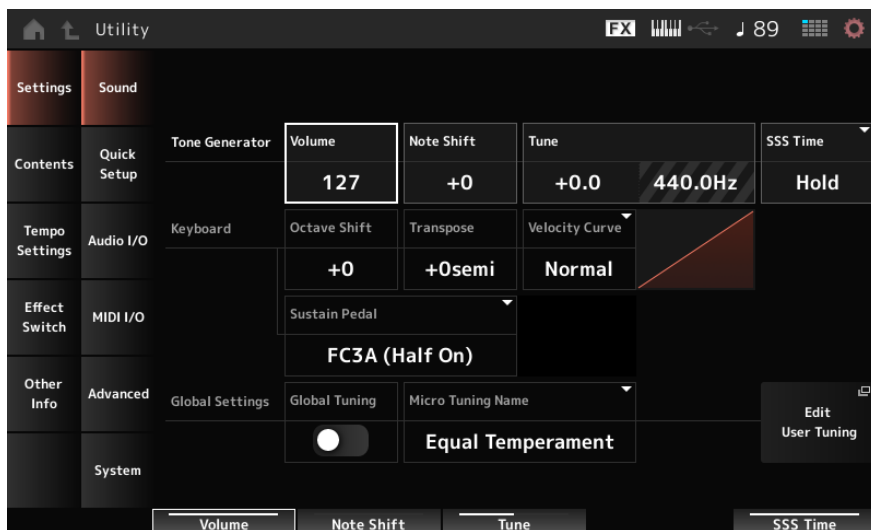

Tone Generator Volume

Sets the overall volume of the sound output from the instrument.

Settings: 0–127

Tone Generator Note Shift

Adjusts the pitch of the overall sound produced by the Tone Generator block of the instrument in semitones.

Settings: –24–+0–+24

Tone Generator Tune

Adjusts the tuning of the overall sound produced by the Tone Generator block of the instrument in semitones. You can fine-adjust the pitch in units of cents.

Settings: –102.4–+0.0–+102.3

SSS Time

Adjusts the SSS Time of the overall sound produced by the Tone Generator block of the instrument. When selected, the Live Set Slot's SSS Time will be applied.

Settings: 0.0sec – 30sec, Hold, System

Keyboard Octave Shift

Shifts the pitch of the keyboard in octaves. It is linked to the [OCTAVE] buttons on the top panel.

Settings: -3--+0--+3

NOTE

The Keyboard Octave Shift setting will be set to 0 the next time you start the program.

Keyboard Transpose

Shifts the pitch of the keyboard in semitones.

Settings: -11semi to +0semi to +11semi

NOTE

- If the pitch exceeds the range (C -2 to G8) that the sound source section of the unit can play, a note one octave higher (or lower) will be output.
- The Keyboard Transpose setting will be set to +0semi the next time you start the program.

Keyboard Velocity Curve

Sets the velocity curve to determine how velocity is expressed in relation to the strength with which the keys are played. The horizontal axis of the graph displayed on the screen of the instrument indicates the strength with which the keys are played, and the vertical axis indicates the velocity output from the keys.

Settings: Normal, Soft 1, Soft 2, Hard 1, Hard 2, Wide, Fixed

Normal: The most common curve, where the strength and velocity of the keystroke are proportional

Soft 1: Provides increased response

Soft 2: The curve between Soft 1 and Normal

Hard 1: Provides decreased response

Hard 2: The curve between Hard 1 and Normal

Wide: A curve that suppresses velocity with a light touch and makes velocity more pronounced with a strong touch. It provides a feeling of a wider dynamic range.

Fixed: Used when you want to create a sound source with a constant velocity regardless of the strength of the key presses. The value set in Keyboard Fixed Velocity is used as the velocity value

Keyboard Fixed Velocity

Sends a fixed velocity to the tone generator regardless of how hard or soft you play the keyboard.

This is only valid if you set the Keyboard Velocity Curve parameter to Fixed.

Settings: 1-127

Sustain Pedal (Sustain Pedal Select)

Select the type of footswitch connected to the FOOT SWITCH [SUSTAIN] jack on the rear panel.

- **FC3, FC3A (half-damper feature enabled)**
Select FC3A (Half On). If you do not need to use the half-damper feature, select FC3A (Half Off).
- **FC4, FC4A, FC5**
Select FC4A or FC5. The half-damper feature is not available with the FC4, FC4A, and FC5.
- **Pedal with reverse polarity**
Select Reverse Polarity. The half-damper feature is not available.

Settings: FC3A (Half On), FC3A (Half Off), FC4A/FC5, Reverse Polarity

NOTE

If you are using control changes from an external MIDI device to play half damper, the Sustain Pedal (Sustain Pedal Select) setting is not necessary.

Global Tuning (Global Micro Tuning Switch)

When this parameter is On, the micro tuning settings in the global settings are prioritized over the micro tuning settings for each Part of the Performance. This applies to all Parts except the Drum Part.

Settings: Off, On

NOTE

The Global Tuning (Global Micro Tuning Switch) setting will be set to Off the next time you start the program.

Micro Tuning Name (Global Micro Tuning Name)

Shows the name of the selected micro tuning. Tapping on the name lets you call up the menu for selecting the micro tuning.

Settings: **Preset:** Equal Temperament, Pure Major, Pure Minor, Werckmeister, Kirnberger, Vallotti & Young, 1/4 shift, 1/4 tone, 1/8 tone, Indian, Arabic1, Arabic2, Arabic3

User: Init Tuning1–8

Library: Library name (when a Library file is loaded)

Root (Global Micro Tuning Root)

Sets the root note for the micro tuning. This parameter is not shown if the selected type in Micro Tuning Name does not require a root note.

Settings: C–B

Edit User Tuning

Opens the User Micro Tuning settings window.

Quick Setup

This function allows you to set all necessary settings for connecting the external device to the optimal values by simply selecting a group of settings.

Parameters across several setting screens can be set all at once to suit the intended purpose.

Operation

[QUICK SETUP]

[UTILITY] → Settings → Quick Setup

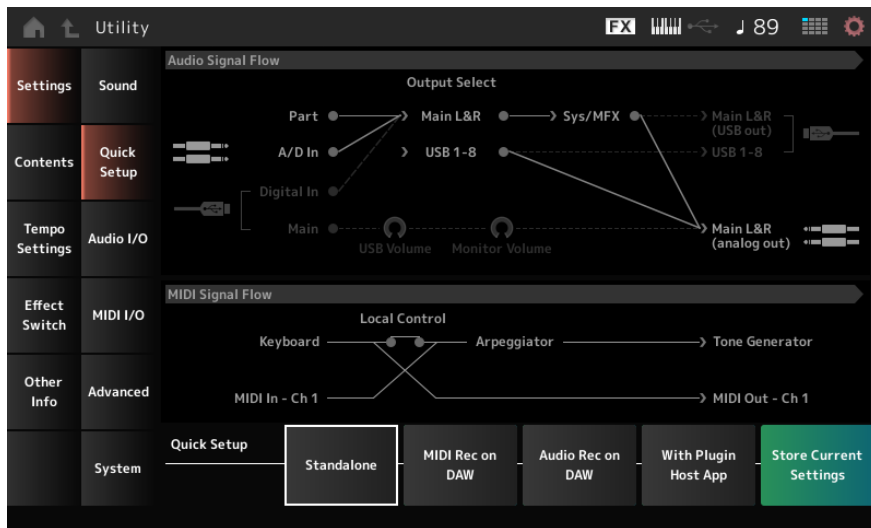

Audio Signal Flow

Displays the current audio signal flow diagram.

The signal flow depicted changes depending on the connection on the USB [TO HOST] terminal and the other settings of the instrument.

MIDI Signal Flow

Displays the current MIDI signal flow diagram.

The signal flow diagram changes depending on the settings of the instrument.

Quick Setup (Quick Setup Select)

Selects Quick Setup.

Settings: Standalone, MIDI Rec on DAW (Setup No.1), Audio Rec on DAW (Setup No.1), With Plugin Host App (Setup No.3)

The parameters stored in each quick setup are as follows:

Audio settings	Direct Monitor
MIDI settings	Local Control
Performance settings	Part 1–16 Output Select A/D In Output Select Digital In Output Select Part 1–8 Keyboard Control Switch Part 1–16 Part Mode Part 1–16 Transmit Channel

See Audio I/O for audio setting parameters and MIDI I/O for MIDI setting parameters.

Quick Setup initial settings

• Standalone

Settings for using the instrument by itself and for operating the external device from the instrument

Direct Monitor	Local Control	Output Select	Keyboard Sw	Part Mode	Transmit Ch
On	On	Main L&R	Part 1–8: On	Part 1–16: Int	Part 1–16: Ch 1–16

• MIDI Rec on DAW

Settings for recording your performance in MIDI on DAW software

Direct Monitor	Local Control	Output Select	Keyboard Sw	Part Mode	Transmit Ch
On	Off	Main L&R	Part 1–8: On	Part 1–16: Int	Part 1–16: Ch 1–16

• Audio Rec on DAW

Settings for recording each Part on the internal Tone Generator to DAW software as an individual audio track

Direct Monitor	Local Control	Output Select	Keyboard Sw	Part Mode	Transmit Ch
Off	On	Different for each Part	Part 1–8: On	Part 1–16: Int	Part 1–16: Ch 1–16

• With Plugin Host App

Settings for using the internal Tone Generator with a sound generator plug-in on a computer

Direct Monitor	Local Control	Output Select	Keyboard Sw	Part Mode	Transmit Ch
On	On	Main L&R	Part 1–5: On Part 6–8: Off	Part 1–4: Int Part 5–16: Ext	Part 1–4: Ch 1–4 Part 5–8: Ch 1–4 Part 9–16: Ch 9–16

Store Current Settings

You can save the current settings to any one of Setup No.1–3 of Quick Setup.

Audio I/O

On the Audio I/O screen, you can set the audio signal input and output.

Operation

[UTILITY] → Settings → Audio I/O

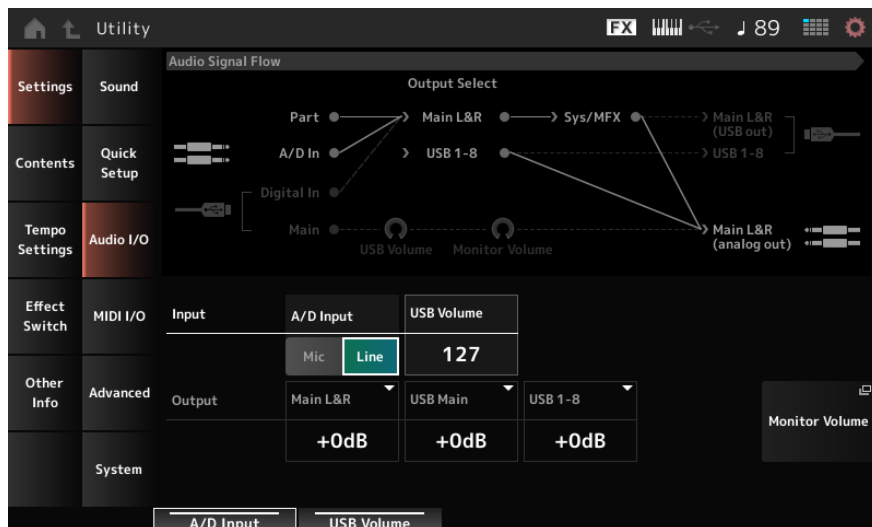

Audio Signal Flow

Displays the current audio signal flow diagram.

The signal flow depicted changes depending on the connection on the USB [TO HOST] terminal and the other settings of the instrument.

A/D Input (A/D Input Gain)

Sets the input gain for the A/D INPUT jack to Mic or Line.

Settings: Mic, Line

Mic: Intended for a device with a low output level, such as a microphone.

Line: Intended for a device with a high output level, such as a synthesizer, or audio device.

NOTE

A guitar or bass having an active pickup can be directly connected. On the other hand, when using a passive pickup, connect the instrument via an effect unit or direct box.

USB Volume (USB Input Volume)

Adjusts the volume of the audio signal input from the USB [TO HOST] terminal.

Settings: 0–127

NOTE

The USB input volume is stored as a system-wide setting and not on a per-performance basis.

Direct Monitor

Sets the audio signal output from Main L&R, USB Main or USB 1–8 channels to the external device (such as a computer) to be also played back from this instrument (direct monitoring).

When this is set to On, the audio signals output to the Main L&R, USB Main, and USB 1–8 channels are also sent to the OUTPUT [L/MONO] and [R] jacks and the [PHONES] jack of the instrument. When there is no USB connection, this is automatically turned On.

Settings: Off, On

Main L&R (Analog Output L&R Output Gain)

Sets the output gain of the OUTPUT [L/MONO] and [R] terminals.

Settings: -6dB, +0dB, +6dB, +12dB

USB Main (USB Main L&R Output Gain)

Sets the output gain of the Main L&R channel of the USB [TO HOST] terminal.

Settings: -6dB, +0dB, +6dB, +12dB

USB 1-8 (USB Individual Output Gain)

Sets the output gain of the channels 1–8 of the USB [TO HOST] terminal.

Settings: -6dB, +0dB, +6dB, +12dB

Monitor Volume

The Monitor Volume screen appears.

MIDI I/O

The MIDI input and output is set on the MIDI I/O screen.

Operation

[UTILITY] → Settings → MIDI I/O

Tap the Quick Setup icon

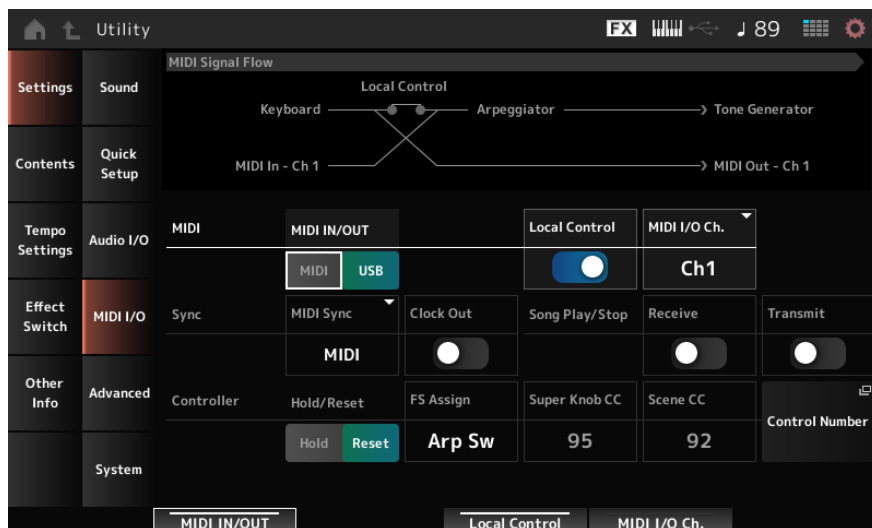

MIDI Signal Flow

Displays the current MIDI signal flow diagram. The flow diagram changes depending on the settings of the instrument. By tapping near the Local Control switch on the MIDI Signal Flow, you can turn Local Control On or Off.

MIDI IN/OUT

Selects the terminal(s) for transmitting and receiving MIDI messages.

Settings: MIDI, USB

MIDI Thru

Specifies whether the MIDI [OUT] terminal is used as a MIDI Thru terminal.

Settings: Off, On

Local Control

Switches Local Control on or off.

When the Local Control is set to Off, the instrument's Controller block and the Tone Generator block will be disconnected, and no sound is produced when you play the keyboard.

However, regardless of this setting, the keyboard performance data on this instrument are transmitted as MIDI messages. In addition, MIDI input messages are processed by the Tone Generator block.

Settings: Off, On

MIDI I/O Channel

Sets the MIDI channel for input and output of the Common and the Part with the Keyboard Control Switch to be set to On.

Settings: Ch1–Ch16

MIDI Sync

Sets the parameters related to synchronization to the connected external device.

Select the internal clock of this instrument or the external MIDI clock of DAW software on the computer or the external MIDI device, or the audio signal input from the A/D INPUT jacks for playing back the Arpeggios, Motion Sequencer, Songs, and Patterns.

Settings: Internal, MIDI, A/D In (ABS)

Internal: Synchronizes to the internal clock. For using this instrument by itself or as the master clock source for other devices to sync to.

MIDI: Synchronizes to the MIDI clock received from the external MIDI device. For using the external device as the master clock source.

A/D In (ABS): Operates by extracting the tempo from the audio signal input from the A/D INPUT terminal using the Audio Beat Sync function.

Clock Out (MIDI Clock Out)

Sets the MIDI clock messages to be transmitted.

Settings: Off, On

Receive (Receive Sequencer Control)

Receives the MIDI messages for starting and stopping the Song.

Settings: Off, On

Transmit (Transmit Sequencer Control)

Transmits the MIDI messages for starting and stopping the Song.

Settings: Off, On

Controller Hold/Reset

Sets whether to use the current settings of the controllers such as modulation wheel, aftertouch, foot controller, and breath controller (Hold) or to reset to their initial settings (Reset) when you switch between Performances.

Settings: Hold, Reset

When set to Reset, the controllers will be reset when you switch between Performances as shown below:

Pitch bend	Center
Modulation wheel	Minimum
Aftertouch	Minimum
Foot controller	Maximum
Footswitch	Off
Ribbon controller	Center
Breath controller	Maximum
Expression	Maximum
Assignable switches 1 and 2	Off
[KEYBOARD HOLD] button	Off
Each lane of the motion sequencer	When the Motion Seq Polarity for the lane is set to Unipolar: the value is 0 (minimum) When the Motion Seq Polarity for the lane is set to Bipolar: the value is 64 (center)

FS Assign (FootSwitch Assign Control Number)

Sets the Control Change number generated by the operation of the footswitch connected to the FOOT SWITCH

[ASSIGNABLE] jack. When this instrument receives a MIDI message with the same Control Change number specified here from the external MIDI device, the instrument will act as if the footswitch has been operated.

Settings: Off, 1–95, Arp Sw, MS Sw, Play/Stop, Live Set+, Live Set–, Oct Reset, Tap Tempo

Super Knob CC (Super Knob Control Change Number)

Sets the Control Change number generated by the operation of the Super Knob.

When this instrument receives the MIDI message with the same Control Change number specified here from the external device, the instrument will act as if the Super Knob has been operated.

Settings: Off, 1–95

NOTE

When this parameter is set to Off, the System Exclusive (SysEx) is used for handling MIDI messages.

Scene CC (Scene Control Change Number)

Sets the Control Change number generated when you switch between Scenes.

Also, Scene will change when a MIDI message with the same Control Change number set here is received from the external MIDI device.

Settings: Off, 1–95

NOTE

- Depending on the Control Change number, one of the Scenes 1–8 will be selected.
0–15: Scene 1, 16–31: Scene 2, 32–47: Scene 3, 48–63: Scene 4, 64–79: Scene 5, 80–95: Scene 6, 96–111: Scene 7, 112–127: Scene 8
- If the Super Knob CC number and the Scene CC number are set to the same value, an exclamation mark appears in front of the number. In that case, the Scene Control Change takes priority, and the Super Knob Control Change is disabled.

Control Number

Opens Control → Control Number on the Common Edit screen.

Advanced

On the Advanced screen, you can set the detailed settings for the instrument.

Operation

[UTILITY] → Settings → Advanced

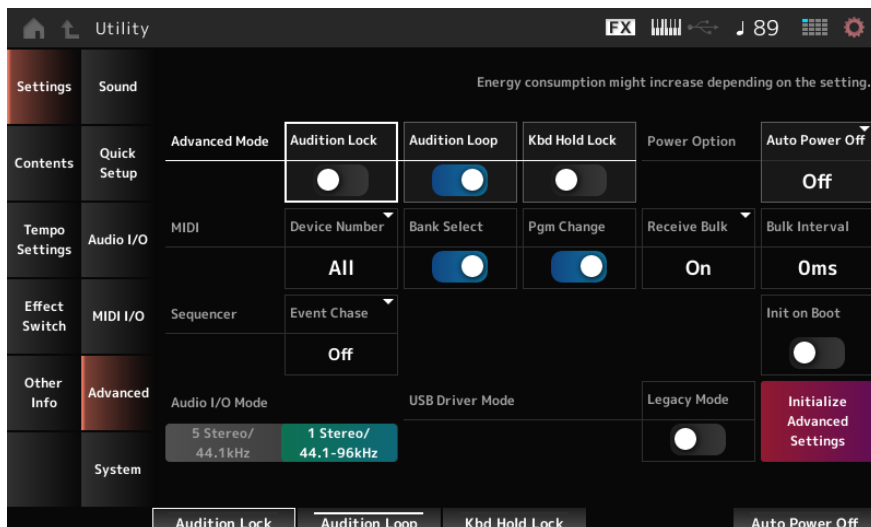

Audition Lock

Switches the audition lock On or Off. When set to On, the audition function is disabled.

Settings: Off, On

Audition Loop

When this is set to On, the audition phrase will be played back in a loop.

When this is set to Off, the playback of the audition phrase will stop automatically after it has been played to the end.

Settings: Off, On

Kbd Hold Lock (Keyboard Hold Lock)

Switches Keyboard hold function On or Off. When set to On, the keyboard hold function is disabled.

It works in conjunction with the [KEYBOARD HOLD] button.

Settings: Off, On

Auto Power Off (Auto Power Off Time)

Auto power off is a function that automatically turns off the power if the unit is not operated for a certain period of time in order to prevent unnecessary power consumption due to leaving the unit on by accident.

Here, you can set the length of time until the instrument is automatically turned off.

Settings: Off (Auto Power Off disabled), 5min, 10min, 15min, 30min, 60min, 120min

Device Number

Sets the MIDI device number. For sending and receiving System Exclusive messages such as Bulk Dump and Parameter Change to and from an external MIDI device, you need to set this number to match the device number of the other device.

Settings: 1–16, All, Off

Bank Select (Receive/Transmit Bank Select)

Sets the reception and transmission of Bank Select messages between the instrument and the external MIDI device. When this is set to On, the instrument will receive or recognize Bank Select messages sent from the external MIDI device.
Settings: Off, On

Pgm Change (Receive/Transmit Program Change)

Sets the reception and transmission of Program Change messages between the instrument and the external MIDI device. When this is set to On, the instrument will receive or recognize Program Change messages sent from the external MIDI device.
Settings: Off, On

Receive Bulk

Sets the reception of Bulk Dump messages.
Settings: Protect (Do not receive), On (Receive)

Bulk Interval

Sets the interval time for transmission of Bulk data when this instrument receives the Bulk Request message from the external device.
Settings: 0–900ms

Sequencer Event Chase (Song Event Chase)

This ensures that specified events to be recognized properly when, for example, a Song is played back from the middle, or with the Forward (fast-forward) and Back (rewind) operations.
Events set with MIDI Event Chase will then function properly with the Forward and Back operations.
Settings: Off, PC (Program Change), PC+PB+Ctrl (Program Change+Pitch Bend+Control Change)

Init On Boot (Initialize User Data on Boot-up)

Sets whether user data is initialized (On) or not (Off) when starting up.
Settings: Off, On

Audio I/O Mode

Switches the output mode for the audio signal output from the USB [TO HOST] terminal.
The instrument must be rebooted for this setting to be effective.
Settings: 5 Stereo/44.1kHz, 1 Stereo/44.1–96kHz

5 Stereo/44.1kHz: Up to 10 channels (5 stereo channels) at a sampling frequency of 44.1 kHz

1 Stereo/44.1-96kHz: Up to 2 channels (1 stereo channel) at a sampling frequency of 44.1 kHz to 96 kHz

NOTE

When set to 1 Stereo/44.1-96kHz, the available frequencies are: 44.1/48/96kHz.

Legacy Mode

Set this to On if you want to use MIDI 1.0 instead of MIDI 2.0.
The instrument must be rebooted for this setting to be effective.
Settings: Off, On

Initialize Advanced Settings

Initializes the settings on the Advanced screen.

System

On the System screen, you can set the parameters related to the entire instrument.

Operation

[UTILITY] → Settings → System

[UTILITY] + [DAW REMOTE] (→ Calibrate Touch Panel setting)

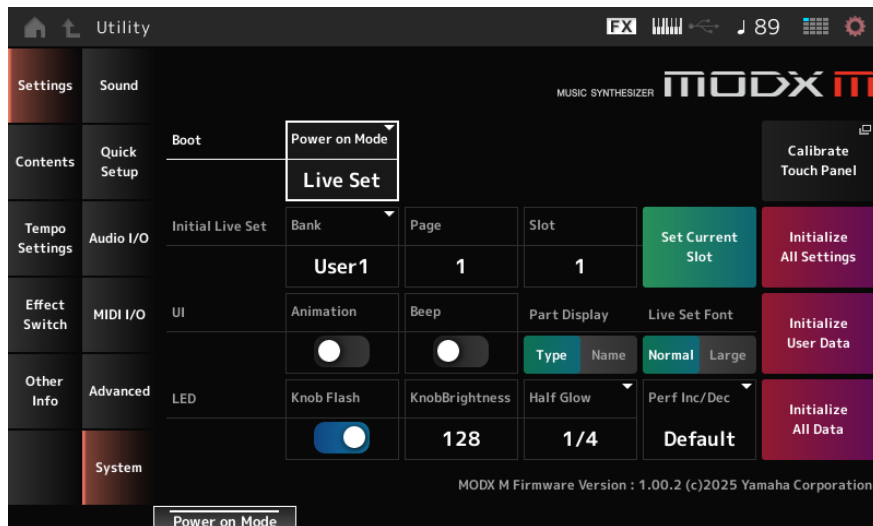

Power on Mode

Sets the screen to be shown on the display when the instrument is turned on.

Settings: Perform, Live Set

Calibrate Touch Panel

Opens the screen for touchscreen calibration. Use it when the touchscreen does not respond correctly.

Initial Live Set Bank (Initial Live Set Bank)

Initial Live Set Page (Initial Live Set Page)

Initial Live Set Slot (Initial Live Set Slot)

When Power on Mode is set to Live Set, this determines the live set slot to be selected immediately after startup.

NOTE

You can also set the slot by selecting a Performance on the Live Set screen, opening this screen, and then tapping the Set Current Slot button.

Set Current Slot (Set Current Slot to Initial Live Set)

Sets the current Performance to the Live Set slot selected after startup.

Initialize All Settings

Initializes all Utility screen settings.

Animation

Sets whether animation is On or Off when the screen switches.

Settings: Off, On

Beep

Turns the touchscreen operation sound on or off.

Settings: Off, On

Part Display

Sets the Part Name to show the Category and Part Type or just Part Name.

Settings: Type, Name

Live Set Font

Determines the font size of the contents names and category names on the Live Set screen and the Category Search screen.

Settings: Normal, Large

Initialize User Data

Initializes all user area data in user memory (performance, motion sequences, live sets, etc.) and all settings on the Utility screen.

Knob Flash (Super Knob LED Blink)

Sets the flashing of the Super Knob on or off.

Settings: Off, On

KnobBrightness

Sets the brightness of lighting on the Super Knob.

Settings: 0–128

Half Glow (LED Half Glow Brightness)

Controls the dimming of the button lamps.

Settings: Off, 1/4, 1/2

Perf Inc/Dec

Sets how performance is switched on the Home screen.

Settings: Default, Live Set

Default: Switches in the order of the Performance list on the Performance Category Search screen

Live Set: Switches in the order of the Live Set slots

Initialize All Data

Initializes all data in User memory and Utility screen settings.

Product Info

Shows the firmware version of the instrument.

NOTICE

Initializing will overwrite all of the target data and system settings to the factory settings.

Be careful not to lose important data. It is also recommended to save the necessary settings to a USB flash drive in advance.

Contents

Load

Files and internal data are loaded using the Load screen.

Operation

[UTILITY] → Contents → Load

[SHIFT] + [STORE]

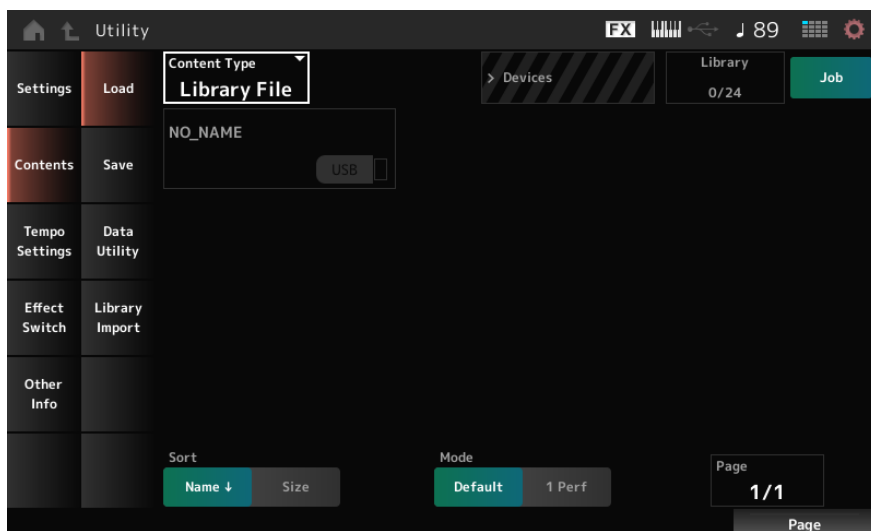

Content Type

All data or a specific set of data is loaded from a single file saved on a USB flash drive or setting stored on the instrument. Here, you can select which set of data in a file to load.

Available settings vary depending on the route you take to open the screen.

Settings: The file types which can be loaded are as follows.

Content Type	Device Type	File extension	Description
User File	File	.Y2U (.Y2W) .X7U .X8U	<ul style="list-style-type: none">• User files saved on a USB drive are loaded into the user area of user memory.• If the user file has been split, both the .Y2U and .Y2W must be stored on the USB drive.• The following settings are included in a User file. Performance, Arpeggio, Motion Sequence, Curve, Live Set, Microtuning, Waveform, Audition, Utility Settings (.Y2U only), Quick Setup (.Y2U only)
Library File	File	.Y2L (.Y2M) .X7L .X8L	<ul style="list-style-type: none">• Library files saved on a USB drive are loaded into the Library area of User memory.• If a Library file has been split both .Y2L and .Y2M must be saved on the USB drive.• The following settings are included in a Library file. Performance, Arpeggio, Motion Sequence, Curve, Live Set (1 bank only), Microtuning, Waveform, Audition

Content Type	Device Type	File extension	Description
Backup File	File	.Y2A (.Y2B) .X7A .X8A	<ul style="list-style-type: none"> • Backup files saved on a USB drive are loaded into the User memory. • A backup file includes everything in the User and Library areas, as well as Songs, and Patterns. • If a backup file has been split, both .Y2A and .Y2B must be saved on the USB drive.
Song&Perf (Song & Performance)	Internal data		<ul style="list-style-type: none"> • Only the specified Song is loaded from Songs stored in the User area of the User memory. • Both MIDI sequences and Performances can be loaded.
Song	Internal data		<ul style="list-style-type: none"> • Only the specified Song is loaded from Songs stored in the User area of the User memory. • Only MIDI sequences can be loaded.
.mid File	File	.MID	Standard MIDI Files (SMF) saved on a USB drive are loaded (either in format 0 or format 1).
.wav File	File	.WAV	Audio files saved on a USB drive are loaded.
Pattern&Perf (Pattern & Performance)	Internal data		<ul style="list-style-type: none"> • Only the specified Pattern is loaded from Patterns stored in the User area of the User memory. • Both MIDI sequences and Performances can be loaded.
Pattern	Internal data		<ul style="list-style-type: none"> • Only the specified Pattern is loaded from Patterns stored in the User area of the User memory. • Only MIDI sequences can be loaded.
Audio File*	File	.WAV .AIF	Audio files saved on a USB drive are loaded as Waveforms. Example: [PERFORMANCE (HOME)] → [EDIT/↶] → Part selection → Element selection → Osc/Tune
Motion Seq (Motion Sequence)*	Internal data		Only the specified sequence is loaded from the Motion Sequences saved (stored) in the User area of the User memory.
Smart Morph*	Internal data		Only Smart Morph data is loaded from the Performance saved (stored) in the User area of User memory.

NOTE

Content types marked with an asterisk (*) are not displayed when this screen is opened from the Utility screen.

Parent Folder Name

Current Folder Name

Indicates the name of the parent folder and the name of the current folder.

Once you tap on the parent folder name, it is then the current folder.

Job

Sets whether the Job function is enabled (On) or disabled (Off).

When this parameter is turned On, tapping on the current file, folder, or content will call up the Rename or Delete context menu.

Tapping on the connected USB flash drive, will call up the Format context menu.

Settings: Off, On

Free Storage

Indicates the used capacity and total capacity of the selected storage.

The indication differs depending on the content type.

Folder file select

Indicates the folders and files within the current folder.

Sort

Set the sort order for the files in file select.

Settings: Name, Size, Date, Default (depending on content type)

Name: Sorts by name. The down arrow indicates that the list is arranged in ascending order (A to Z). The up arrow indicates that the list is arranged in descending order.

Size: Sorts in order of data size. The down arrow indicates that the list is in ascending order (small to large). The up arrow indicates that the list is in descending order. Invalid for content types Motion Seq, Song, Song&Perf, Pattern, Pattern&Perf, Performance, Smart Morph

Date: Sorts by date the setting was stored. The down arrow indicates that the list is arranged in descending order (new to old). The up arrow indicates that the list is arranged in ascending order. This is available only when the content type is Motion Seq, Song, Song&Perf, Pattern, Pattern&Perf, Performance, Smart Morph

Default: Sorts in ascending order of content number. This is available only when the content type is Song, Song&Perf, Pattern, Pattern&Perf, Performance, Motion Seq, Smart Morph

Mode

Selects the mode for loading.

This is displayed only for a User File or a Library File.

Settings: Default, 1 Perf

Default: Loads all Performances

1 Perf: Loads only a specified Performance

Key (Center Key)

Select the key to which the loaded WAV or AIFF is to be assigned.

This is shown only for audio files.

Settings: Keyboard Select (C-2 -G8), All

Keyboard Select

Set whether Center Key is updated by keyboard operation.

This is shown only for audio files.

Page

If the files appearing in the file select cannot fit on a single page, a scroll button will appear to allow you to select a page.

Alternately you can use a Display knob to select a page.

Save

On the Save screen, you can save files and internal data.
This is basically the same as the Load screen.

Operation

[UTILITY] → Contents → Save

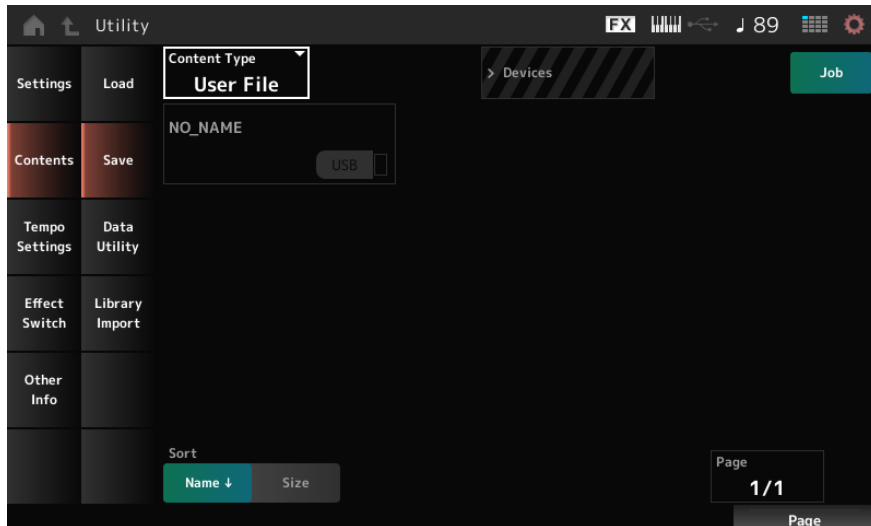

Content Type

All data or a specified portion of data from files stored on a USB drive or the main unit can be retrieved and loaded into the instrument.

Here, you can set which data to store or save.

Available settings vary depending on the route you take to open the screen.

Settings: The following table shows the content types that can be stored or saved.

Content Type	Device Type	File extension	Description
Performance	Internal data		Saves (Stores) the Performance to the User area of the User memory.
User File	File	.Y2U (.Y2W)	<ul style="list-style-type: none"> Settings saved (stored) in the User area of User memory are saved to a USB drive as a User file. The following settings are included in a User file. Performance, Arpeggio, Motion Sequence, Curve, Live Set, Microtuning, Waveform, Audition, Utility Settings, Quick Setup When the file size exceeds 2 GB and the file has been divided, both .Y2U and .Y2W must be handled as a set.
Library File	File	.Y2L (.Y2M)	<ul style="list-style-type: none"> Settings saved (stored) in the Library area of User memory are saved to a USB drive as a Library file. The settings contained in the Library file are as follows (same as the User File, except for the utility settings): Performance, Arpeggio, Motion Sequence, Curve, Live Set (1 bank only), Microtuning, Waveform, Audition When the file size exceeds 2 GB and the file has been divided, both .Y2L and .Y2M must be handled as a set.
Backup File	File	.Y2A (.Y2B)	<ul style="list-style-type: none"> Settings stored in the User memory are saved to a USB drive as a backup file. A backup file includes everything in the User and Library areas, as well as Songs, and Patterns. When the file size exceeds 2 GB and the file has been divided, both .Y2A and .Y2B must be handled as a set.

Content Type	Device Type	File extension	Description
.mid File	File	.MID	MIDI data stored in the Song and Pattern area of User memory is saved to a USB drive as a Standard MIDI File (SMF; only in format 1).
Motion Seq (Motion Sequence)*	Internal data		Stores (saves) the Motion Sequence being edited to the User area.

NOTE

Content types marked with an asterisk (*) are not displayed when this screen is opened from the Utility screen.

Data Utility

On the Data Utility screen, you can manage files and data in User memory. This is basically the same as the Load screen.

Operation

[UTILITY] → Contents → Data Utility

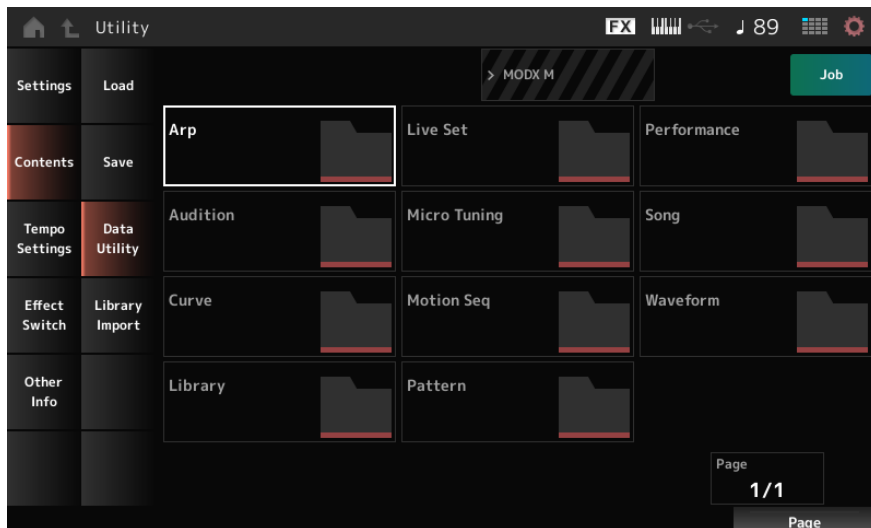

Folder select

Shows the Content types in User memory as folders. Tap the folder to open.

Content Type: Arp, Audition, Curve, Library, Live Set, Micro Tuning, Motion Seq, Pattern, Performance, Song, Waveform

Content Select

Tapping the content calls up the Rename, Delete context menu.

When Job is set to On, the following three items are displayed.

Select All

Selects all of the contents in the folder.

Displayed when nothing has been selected.

Unselect All

Unselects all of the contents in the folder.

Displayed when any of the contents have been selected.

Delete

Deletes all selected content.

Displayed when any of the contents have been selected

Library Import

This function selects a specific performance from the library and copies it to the user bank.
This is basically the same as the Load screen.

Operation

[UTILITY] → Contents → Library Import

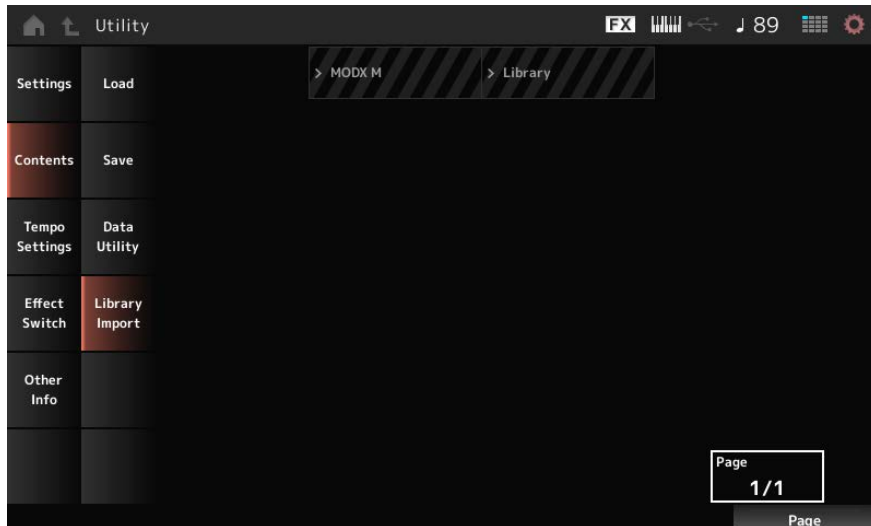

Select All

Selects all Performances in the current library folder.
Shown only when no Performance has been selected.

Unselect All

Deselects all Performances in the current library folder.
Displayed only when any Performance has been selected.

Import to User Bank

Copies the selected Performance to the User Bank.

When this operation is carried out, the User Waveforms and User Arpeggios, User Curves, User Micro Tuning, and User Auditions used in the selected Performance are also copied to the User Bank.

Displayed only when any performance has been selected.

Tempo Settings

On the Tempo Settings screen, you can set the parameters related to tempo and synchronization.

Operation

[TEMPO/TAP]

[UTILITY] + Tempo Settings

Tap the TEMPO SETTINGS icon

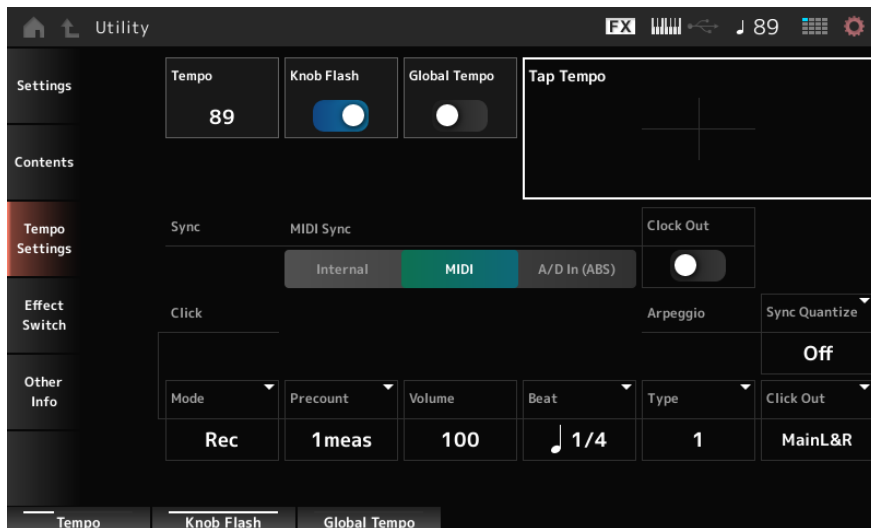

Tempo

Sets the Performance tempo.

If MIDI Sync is set to MIDI or A/D In (ABS) and is synchronized with an external device, Ex.Tempo will be displayed instead of the setting value.

Settings: 5–300

Knob Flash (Super Knob LED Blink)

Sets the flashing of the Super Knob On or Off.

Settings: Off, On

Global Tempo

When this parameter is set to Off, the Tempo setting for each Performance is used.

When set to On, the current tempo is retained even when you change the Performance.

Settings: Off, On

Tap Tempo

By tapping this area or by pressing (tapping) the [ENTER] button while the cursor is present, you can set the tempo to the tap or press speed.

Or you can use the [TEMPO/TAP] button to set the tempo in the same way.

However, this parameter is not available when MIDI Sync is set to MIDI and the instrument is set to synchronize to an external device.

NOTE

If MIDI Sync is set to “A/D In (ABS)”, the tempo is changed with the tap serving as the beginning of the beat.

MIDI Sync

Sets the parameters related to synchronization to the connected external device.

You can choose whether to play Arpeggio, Motion Sequencer, and Song using the internal clock of the instrument, using the clock (external clock) of the DAW software or MIDI devices connected to this unit, or using audio signals input from the A/D INPUT terminal.

Settings: Internal, MIDI, A/D In (ABS)

Internal: Synchronizes to the internal clock. For using this instrument by itself or as the master clock source for other devices.

MIDI: Synchronizes to the MIDI clock received from the external MIDI device. For using the external device as the master clock source.

A/D In (ABS): Operates by extracting the tempo from the audio signal input from the A/D INPUT terminal using the Audio Beat Sync function.

Clock Out (MIDI Clock Out)

Sets the MIDI clock messages to be transmitted.

Settings: Off, On

Sync Quantize (Arpeggio Synchro Quantize Value)

Adjusts the timing for starting the next Arpeggio if playing back an Arpeggio for multiple Parts. When set to Off, the Arpeggio is played back when the Part is played on the keyboard.

Settings: "Off, 60 (thirty-second note), 80 (sixteenth note triplet), 120 (sixteenth note), 160 (eighth note triplet), 240 (eighth note), 320 (quarter note triplet), 480 (quarter note)"

Mode (Click Mode)

Set the timing for when the click sound (metronome sound) is played.

Settings: Off, Rec, Rec/Play, Always

Off: No click sound is played.

Rec: The click sound is played during Song or Pattern recording.

Rec/Play: The click sound is played during Song or Pattern recording and playback.

Always: The click sound is always played.

NOTE

The click sound is played using an internal tone generator, so some of the simultaneous sound output will be consumed.

Precount (Click Precount)

Sets the number of count-in measures from the time the [▶] (Play) button is pressed until recording actually starts when recording a Song or Pattern.

Settings: Off (recording starts as soon as you press the [▶] (Play) button), 1meas–8meas

Volume (Click Volume)

Sets the volume for the click sound.

Settings: 0–127

Beat (Click Beat)

Sets the beat at which the click sound is played.

Settings: 1/16 (sixteenth notes), 1/8 (eighth notes), 1/4 (quarter notes), 1/2 (half notes), Whole (whole notes)

Type (Click Type)

Selects the type of click sound.

Settings: 1–10

Click Out (Click Output Select)

Sets the output destination for the click sound.

Settings: MainL&R, (AsgnL&R), USB Stereo, (AsgnL), (AsgnR), USB mono

MainL&R: Outputs in stereo (two channels) to the OUTPUT [L/MONO] and OUTPUT [R] jacks.

USB Stereo: Outputs in stereo (channels 1 and 2, to channels 7 and 8) to the USB [TO HOST] terminal

USB mono: Outputs in mono (channels 1 to 8) to the USB [TO HOST] terminal

NOTE

The settings for data compatibility with MONTAGE M are shown below. They are considered Off when set.

- AsgnL&R
- USB Stereo: USB9&10 – USB29&30
- USB mono: USB9 – USB30
- AsgnL
- AsgnR

Effect Switch

On the Effect Switch screen, you can set the parameters related to effect bypass.

The settings on this screen are not saved (stored), so the settings are reset to the default when the instrument is restarted.

Operation

[UTILITY] → Effect Switch

Tap the EFFECT icon ([FX])

[SHIFT] + [QUICK SETUP]

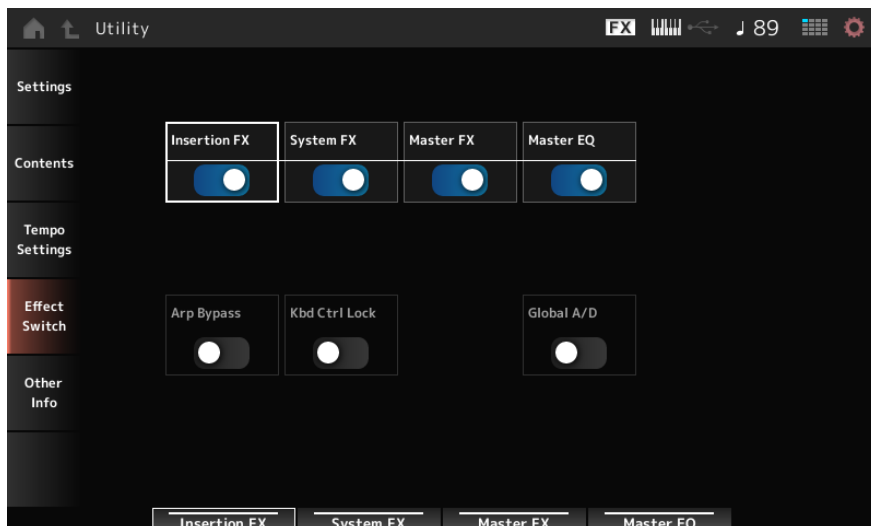

Insertion FX (Insertion Effect)

Sets the Insertion Effect on or off.

Settings: Off, On

System FX (System Effect)

Sets the System Effect on or off.

Settings: Off, On

Master FX (Master Effect)

Sets the Master Effect on or off.

Settings: Off, On

Master EQ

Sets the Master EQ on or off.

Settings: Off, On

Arp Bypass (Arpeggio Bypass)

Sets the Arpeggio Bypass on or off. When this parameter is set to On, all Arpeggio operations are disabled.

Settings: Off, On

NOTE

- When Arp Bypass On, the [ARP] button flashes.
- When Arp Bypass is set to On, if you change the Arpeggio Switch for each Part, Arp Bypass will be set to Off.
- The Songs recorded by using the Arpeggio function will have the Arpeggio sequence included in the data. If you continue to edit the song data in the DAW software, setting Arp Bypass to On prevents the arpeggiator from having a double effect.

Kbd Ctrl Lock (Keyboard Control Lock)

Sets lock for the Keyboard Control on or off.

When set to On, the lock is activated and Keyboard Control for all parts is disabled. Turning it off unlocks Keyboard Control.

This is useful for creating or editing each MIDI track separately, for example, when using the instrument as a 16-part multi-timbral sound module with the DAW software.

Settings: Off, On

NOTE

When Kbd Ctrl Lock is On, if you change Keyboard Control SW of each part, Kbd Ctrl Lock will be set to Off.

Global A/D

When this parameter is set to On, the volume of the A/D Part does not change when switching between performances, and other parameters related to the A/D part do not change. When this parameter is set to Off, the volume changes to a performance-specific setting when switching between performances, and other parameters related to the A/D part will change.

Master FX and Master EQ are switched on and off simultaneously.

Settings: Off, On

Other Info

Other information is displayed on the Other Info screen.

Shift Function

Shows the list of shortcut operations for simultaneous pressing of the [SHIFT] button and other buttons.

Legal Notices

Shows content such as copyrights.

Screens shown by pressing specific buttons

Panel Lock

Using the panel lock function prevents accidental operation during live performances.

Operation

When the Home screen or the Live Set screen is shown, press [SHIFT]+[TEMPO/TAP]

■ Valid operations

Keyboard, pedals, Master Volume, Super Knob, Pitch bend wheel, Modulation wheel, Ribbon controller, and panel lock disengage

■ Invalid operation

All other operations, including touchscreen operations

How to disengage the panel lock

To unlock the panel, hold the [SHIFT] button again while tapping the [TEMPO/TAP] button to unlock the panel.

Split Job

Sets the split.

Operation

Press the [SPLIT] button.

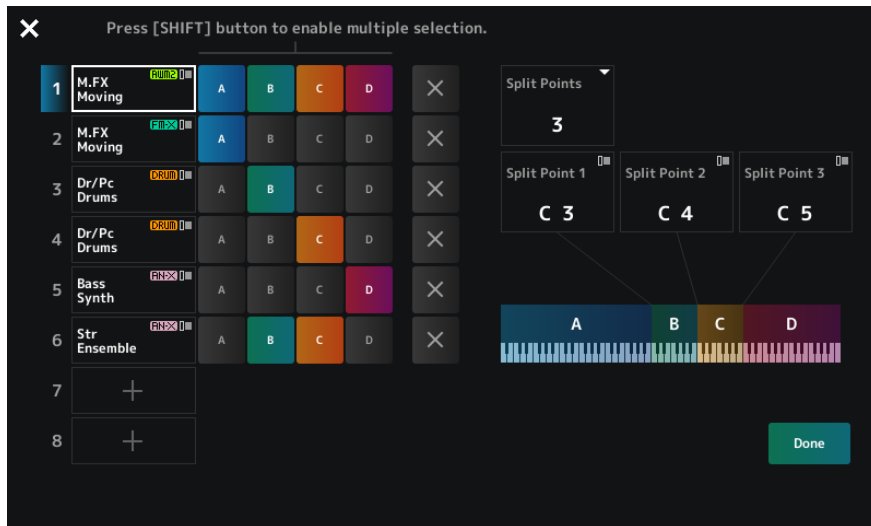

Split Points

Specifies the number of split points.

Settings: Off, 1–3

Split Point 1–3

Specifies the key for the split point.

When Keyboard is set to On, you can also specify the split point position using the keyboard.

Settings: C#–2 – G8

Part Name

Tapping on the Part name calls up the context menu for Category Search and Delete.

[+](Add)

Tap to display the Part Category Search screen or Performance Merge screen, which allows you to add a Part.

Group A–D

Press a Group button to assign the Part to the group.

Tap the group buttons while holding down the [SHIFT] button to assign a single Part to multiple groups.

× (Cancel)

Cancels group assignments.

Done

Confirms the settings and closes the screen.

NOTE

Tapping the × (close) on the upper left closes the screen without confirming settings other than adding, deleting, or changing parts.

Note Range

Operation

[SHIFT] + [SPLIT]



The Part - Note view is shown on the Home screen.

The cursor will move to TG Note Limit Low of the selected part, and you can enter the lower limit of the note range on the keyboard.

Navigation

Operation

Press the [NAVIGATION] button

(With the (Home screen View Modeset to Default) Tap Navigation displayed on the screen)

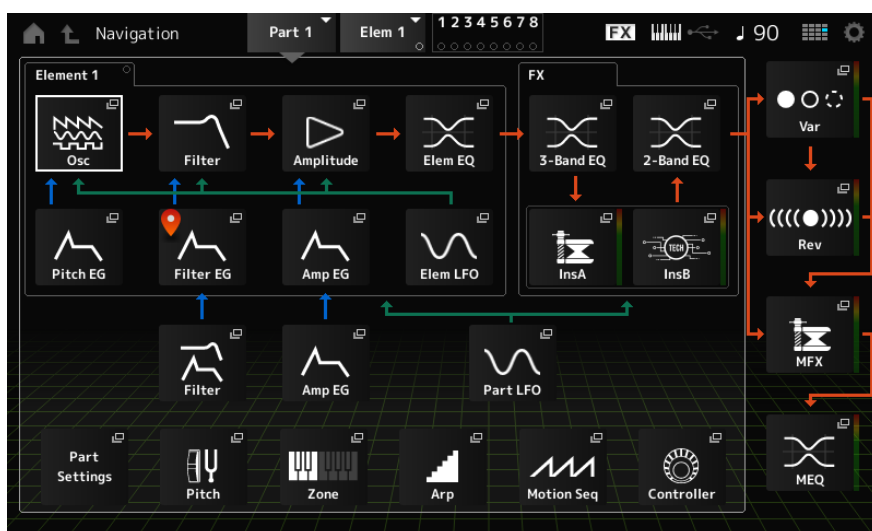

Tapping the icons calls up the corresponding setting screens.

Pressing the [NAVIGATION] button during editing calls up the current location icon (📍).

From the Navigation screen, you can jump not only to elements, but also to the Part Common's Filter and Amp EG.

FX Overview

On the FX OVERVIEW screen, you can check the status of effect settings and easily access screens for advanced settings.

Operation

[SHIFT] + [NAVIGATION]

(With the Home screen View Mode set to Default) Tap the Fx Overview displayed on the screen

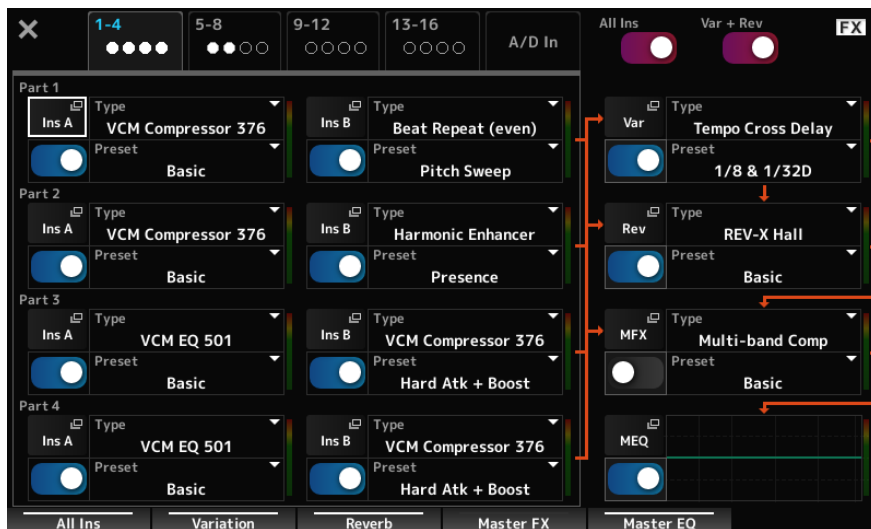

Switching Parts for display

Switches the Parts to display.

Settings: 1-4, 5-8, 9-12, 13-16, A/D In

All Ins

Turns all Insertion Effects (A and B) on or off.

Settings: Off, On

Var + Rev

Turns the Variation and Reverb effects on or off.

Settings: Off, On

Ins A, Ins B, Var, Rev, MFX, MEQ

Shows the corresponding screen for detailed settings.

Effect switch

Switches each effect on or off.

Settings: Off, On

Type

Sets the type for each effect.

Settings: Refer to the Effect types

Preset

Sets the preset for each effect.

Settings: Refer to the Data List

Store

This is the confirmation screen when saving (storing) the current Performance in the User area.

Operation

[STORE]

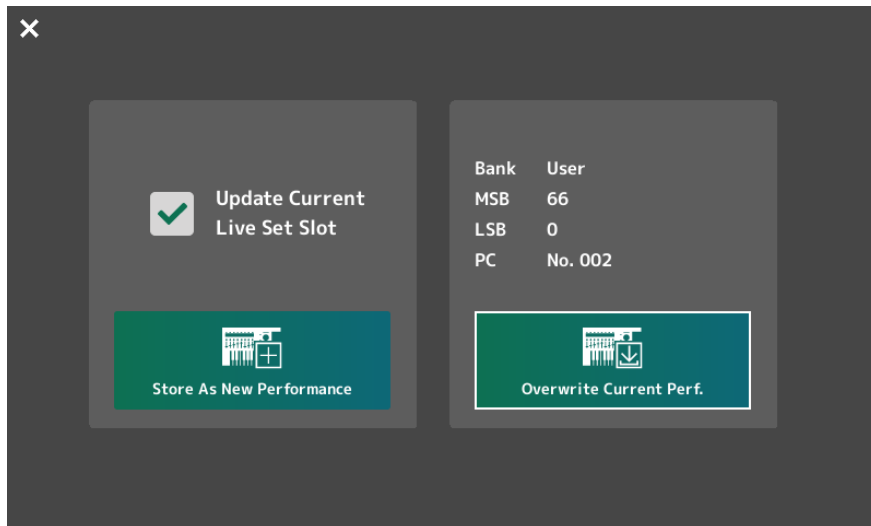

Store As New Performance

Registers as a new Performance.

Update Current Live Set Slot

When a slot in the User Live Set bank is selected, a message confirming the update of the Live Set slot will appear. To proceed with the update, check the box and select Store As New Performance.

Overwrite Current Perf.

Saves the Performance you are editing over the existing settings (Bank, MSB, LSB, and Program Change number) shown on the display.

Jump to Data Utility

Displayed when saving is not possible due to an error such as Performance full.

Use [UTILITY] → Contents → Data Utility to display the screen.

DAW Remote

Pressing the [DAW REMOTE] button enables the DAW remote function, allowing you to conveniently control your preferred DAW with the controllers on the instrument.

Operation

[DAW REMOTE]

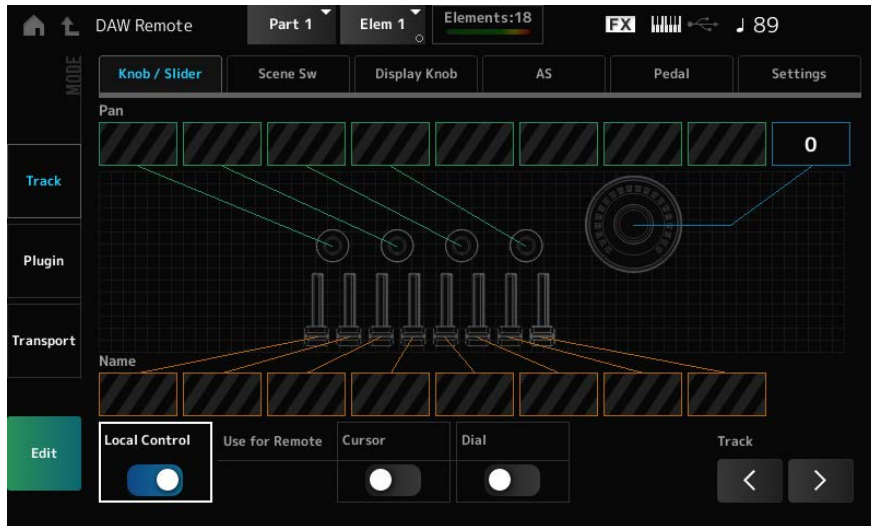

Mode (Remote Control Mode)

Select the DAW remote function from three modes of operation.

Settings: Track, Plugin, Transport

Track: Mode for controlling multiple tracks on the DAW at once. Knob and control slider operations are sent as Mackie Control compatible protocols from Port 2.

Plugin: Mode for controlling a specific plugin on the DAW. Knob and control slider operations are sent as messages in CC Number format for Remote functions from Port 1.

Transport: Mode for playing the keyboard while playing back the recorded data on the DAW, or recording your keyboard performance on the DAW. You can use the Sequencer transport buttons to start or stop the playback on the DAW. All controllers except the Sequencer transport buttons operate as they normally do.

Switching screens

Opens the settings screen for each controller and the remote function.

Settings: Knob/Slider, Scene Sw, Display Knob, AS, Pedal, Settings

Local Control

Sets Local Control On or Off.

This is the same as what can be set in [UTILITY] → Settings → MIDI I/O.

Use for Remote Cursor / Dial

Sets whether to use the Data dial and Cursor buttons on the Top panel for controlling the DAW.

On: For controlling the DAW.

Off: For controlling the Main display on the top panel.

Track (Track Select)

Outputs the Track group selection (by eight tracks at a time).

For using controllers

■ Track mode

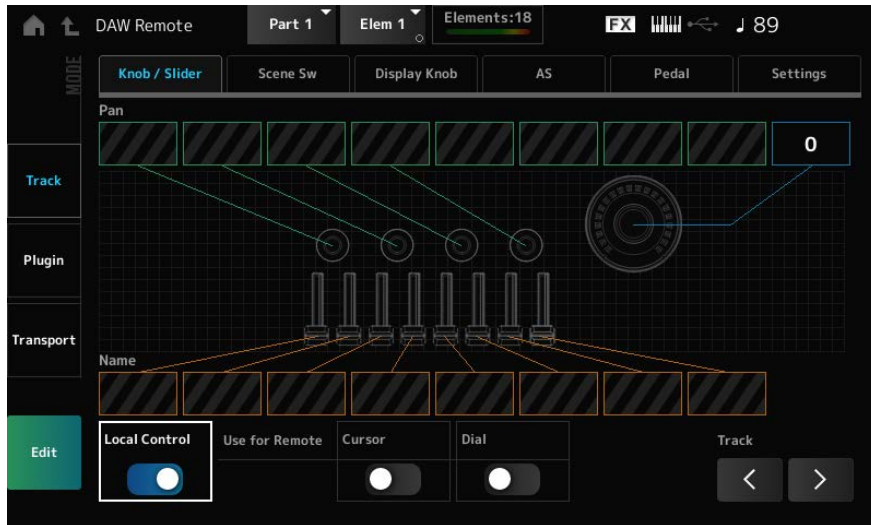

Controllers

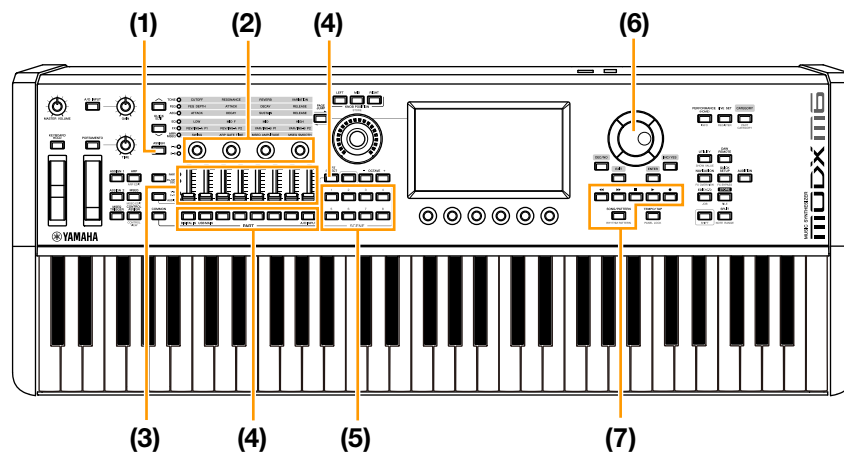

	Controllers	DAW operation
(1)	[ASSIGN] button	Pan selection (1 – 4 / 5 – 8)
(2)	Knob 1 – 4 (5 – 8)	Track Pan is output from Port2
(3)	Control sliders 1–8	Track volume is output from Port2
(4)	PART button, [PART SELECT] button	Selects track(s), and switches mute and solo of the selected track(s) on or off.
(5)	SCENE buttons	Functions 1 – 8 are output from Port2
(6)	Data dial, cursor buttons	Moves the cursor position or Song position.
(7)	Sequencer transport button. [SONG/PATTERN] button	Controls the transport actions (recording and playback).

Other controllers are set to send the Control Change messages set in remote mode.

■ Plugin mode

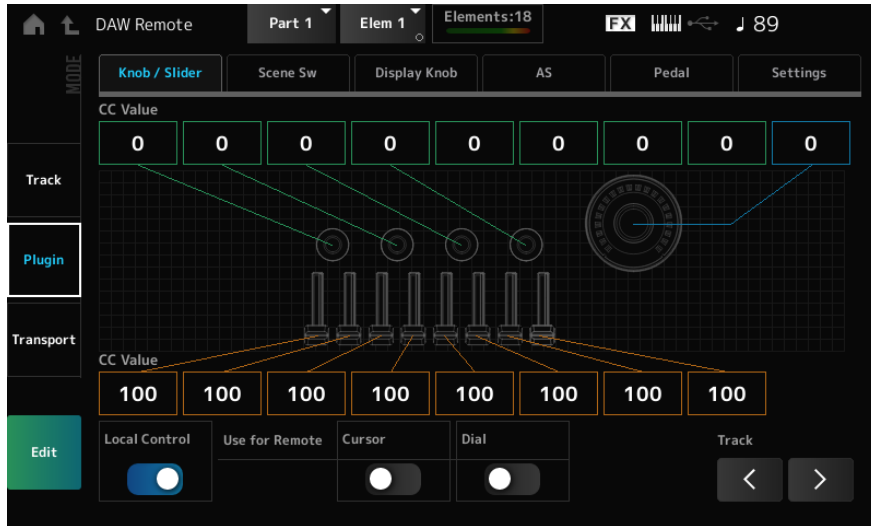

Controllers

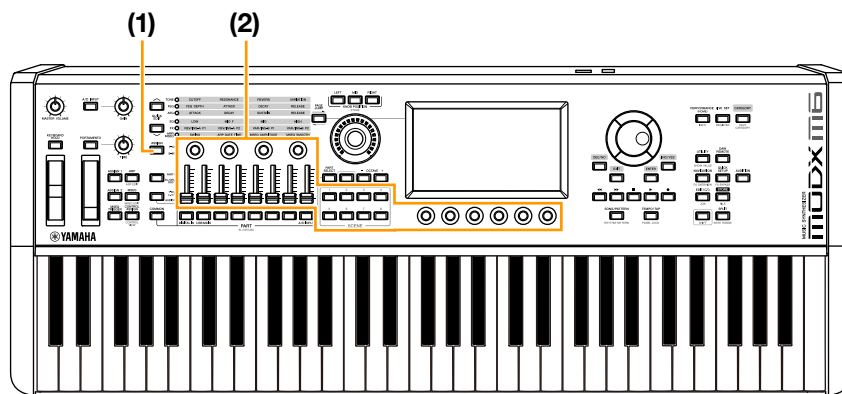

	Controllers	DAW operation
(1)	[ASSIGN] button	Knob selection (1 – 4 / 5 – 8)
(2)	Knobs 1 – 4 (5 – 8), Control sliders 1 – 8, SCENE button, Display knob	Any Control Change you have selected. (The CC number set in Edit on the DAW Remote screen will be output.)

PART buttons, [PART SELECT] button, [KEYBOARD CONTROL] button, data dial, cursor buttons, sequencer transport buttons, BANK buttons, and PAGE buttons behave the same way as in Track mode.

■ Transport mode

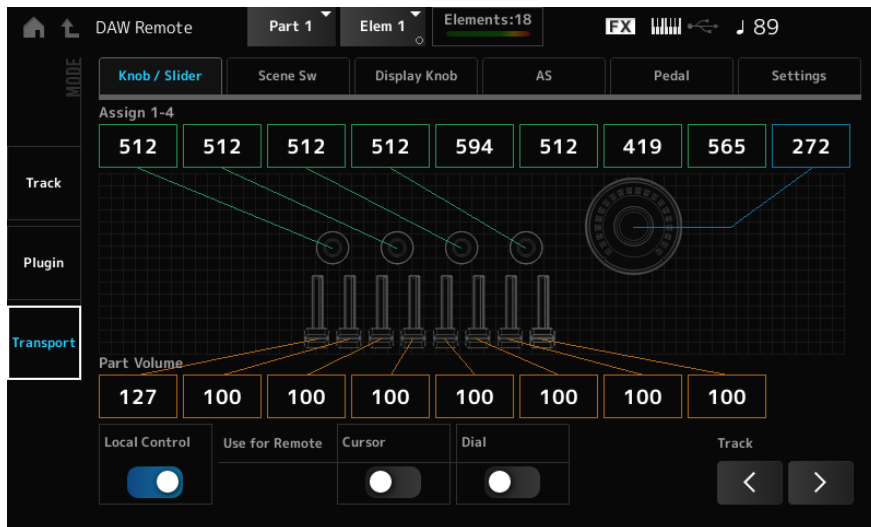

Controllers

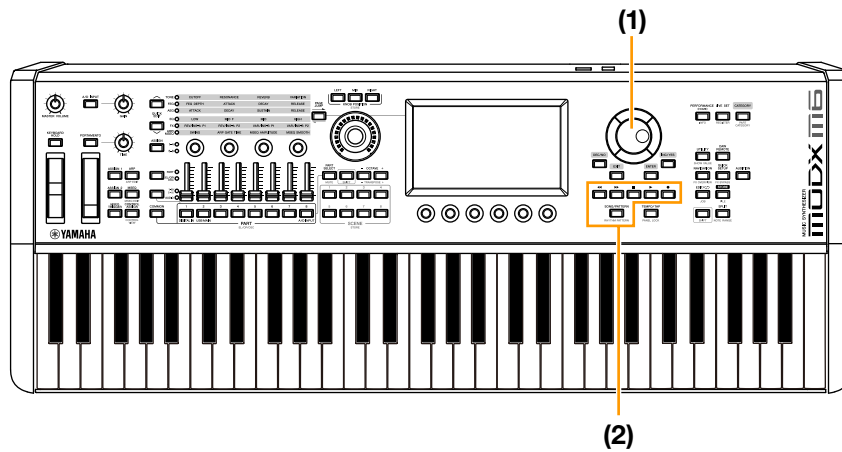

	Controllers	DAW operation
(1)	Data dial, cursor buttons	Moves the cursor position or Song position.
(2)	Sequencer transport button. [SONG/PATTERN] button	Controls the transport actions (recording and playback).

Other controllers operate as normal.

During Edit

Edit

Sets the Control Change message, such as the control number and channel mode, that is output from Port 1.

The settings on each tab are as follows:

■ Common

Local (Local Control)

Sets Local Control On or Off.

This is the same as what can be set in [UTILITY] → Settings → MIDI I/O.

Use for Remote Cursor / Dial

Sets whether to use the Data dial and Cursor buttons on the Top panel for controlling the DAW.

On: For controlling the DAW.

Off: For controlling the Main display on the top panel.

■ Knob / Slider

CC Num. (Control Change Number)

Sets the control number for the knobs and control sliders.

Settings: 1–95

■ Scene SW

Scene1–8CC# (Scene 1–8 Control Number)

Sets the control number for the SCENE buttons.

Settings: 1–95

Latch/Momentary (Scene 1–8 Switch Mode)

Switches the operating mode of the SCENE buttons.

Settings: Momentary, Latch

■ Display Knob

DispKnob 1–6CC# (Display Knob 1–6 Control Number)

Sets the control number for the Display Knobs.

Settings: 1–95

AS

Porta Sw CC# (Portamento Switch Control Number)

Sets the control number for the [PORTAMENTO] button.

Settings: 1–95

Latch/Momentary (Portamento Switch Mode)

Switches the operating mode of the [PORTAMENTO] button.

Settings: Momentary, Latch

Porta Knob CC# (Portamento Knob Control Number)

Sets the control number for the PORTAMENTO [TIME] knob.

Settings: 1–95

AssignSw 1 CC# (Assignable Switch 1 Control Number)**AssignSw 2 CC# (Assignable Switch 2 Control Number)****MS Trigger CC# (Motion Seq Trigger Switch Control Number)**

Sets the control numbers for the [ASSIGN 1] button, [ASSIGN 2] button, and [MSEQ TRIGGER] button.

Settings: 1–95

Assign SW 1 Latch/Momentary (Assignable Switch 1 Mode)**Assign SW 2 Latch/Momentary (Assignable Switch 2 Mode)****MS Trigger Latch/Momentary (Motion Seq Trigger Switch Mode)**

Switches the operating mode of the [ASSIGN 1] button, [ASSIGN 2] button, and [MSEQ TRIGGER] button.

Settings: Momentary, Latch

■ Pedal**FC 1 CC# (Foot Controller 1 Control Number)****FC 2 CC# (Foot Controller 2 Control Number)**

Sets the control number for Foot Controller 1 and Foot Controller 2.

Settings: 1–95

FS CC# (Foot Switch Control Number)

Shows the control number for the foot switch.

Settings: 1–95

Latch/Momentary (Foot Switch Mode)

Switches the operating mode of the foot switch.

Settings: Momentary, Latch

■ Settings**DAW**

Selects the particular DAW for use with this instrument.

Settings: Cubase, Logic Pro, Pro Tools, Live

MIDI I/O Ch.

Sets the MIDI channel for input and output of the Common and the Part with the Keyboard Control Switch to be set to On.

The MIDI channel set here is used also for sending the Control Change message from DAW Remote.

This is the same as what can be set in [UTILITY] → Settings → MIDI I/O.

Settings: Ch1–Ch16

Control Assign

Register the combination of Source and Destination in the Controller Set.

Operation

Press the [CONTROL ASSIGN] button while selecting parameters that can be assigned to the controller on the screen.

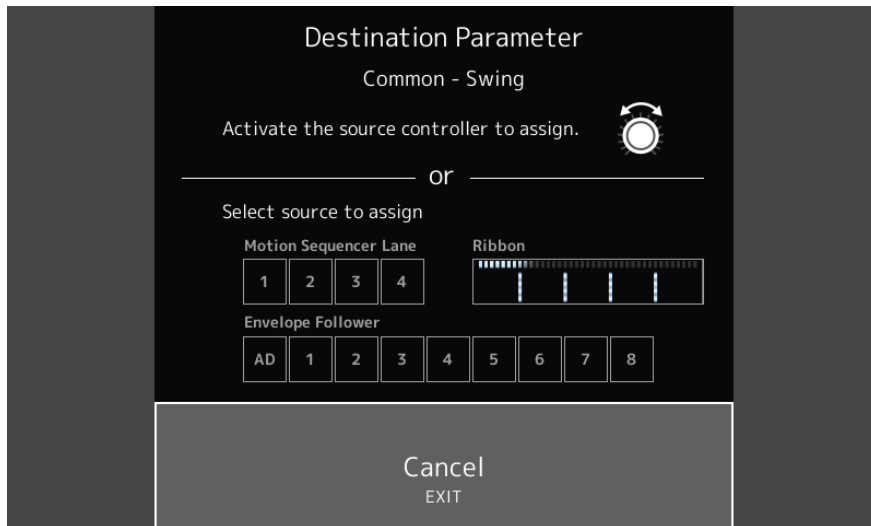

Operate the controller used to adjust the target parameter, or select Motion Sequencer Lane, Envelope Follower, or Ribbon on the screen.

NOTE

- When you move the Super Knob but there aren't any unused assignable knobs to proceed with the setting, an error message will appear.
- When a Part parameter is selected, press the [COMMON] button while operating the assignable knob to select the assignable knob for Common.

Control View

You can check the settings of the controller being operated.

Operation

[SHIFT] + [CONTROL ASSIGN]

(With the Home screen View Mode set to Default) Tap the Control View displayed on the screen.

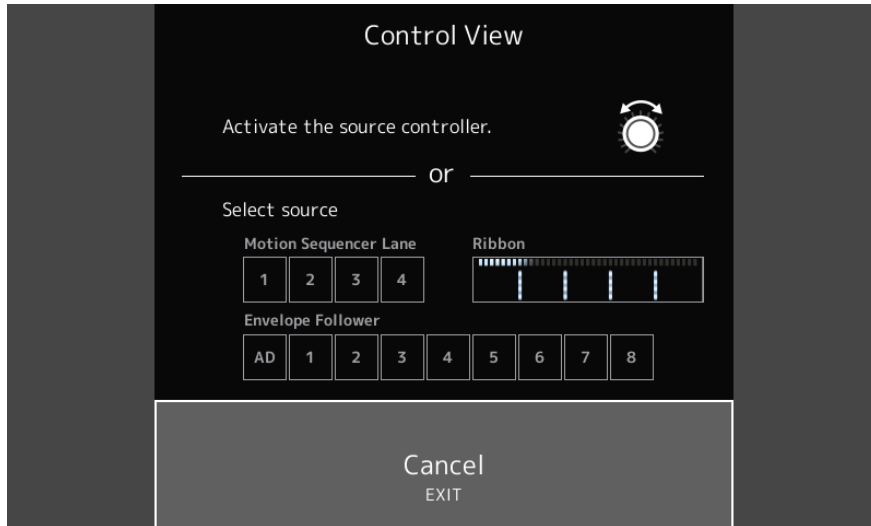

Operate the controller you want to check, or select Motion Sequencer Lane, Envelope Follower, or Ribbon on the screen. The Control Assign screen will open where you can view the settings information.

7. Other information

Effect types

No Effect	Disables the Effects. Does not output the sound.
Thru	Sets the Effect to Thru. The input sound is output without any effects being applied.

Reverb

HD Hall	Simulates the natural acoustics of a concert hall.
REV-X Hall	Hall reverb using the REV-X reverb algorithm
R3 Hall	Hall reverb using the reverb algorithm of the ProR3 Digital Reverb Processor
SPX Hall	Hall reverb from the classic SPX1000
HD Room	Simulates the natural acoustics of a room.
REV-X Room	Room reverb using the REV-X reverb algorithm
R3 Room	Room reverb using the reverb algorithm of the ProR3 Digital Reverb Processor
SPX Room	Room reverb from the classic SPX1000
HD Plate	Simulates a plate reverb.
R3 Plate	Plate reverb using the reverb algorithm of the ProR3 Digital Reverb Processor
SPX Stage	Stage reverb from the classic SPX1000.
Space Simulator	Allows you to specify the width, height, and depth of the room size.
Gated Reverb	Produces a gated reverb.
Reverse Reverb	Produces reverse playback of a gated reverb.
Shimmer Reverb	Creates mystical shimmering effects by adding pitch-changed Reverb sounds.

Delay

Cross Delay	The feedback of the delayed sound on each of the two channels is routed to the opposite channel. Produces alternate delayed sounds on the right and left.
Tempo Cross Delay	Tempo-synchronized Cross delay
Tempo Delay Mono	Tempo-synchronized Mono delay
Tempo Delay Stereo	Tempo-synchronized Stereo delay
Control Delay	Delay for creating scratch sounds by changing the delay length in real-time.
Delay LR	Produces two delayed sounds on the left and right, with two feedback delays.
Delay LCR	Produces three delayed sounds on the left, center, and right.
Analog Delay Retro	Simulates a bucket-brigade analog delay, set to short delay.
Analog Delay Modern	Simulates a bucket-brigade analog delay, set to long delay.

Chorus

G Chorus	Creates a deep sound with complex modulation.
2 Modulator	Allows you to set the pitch modulation and amplitude modulation. Spreads out the sound naturally.
SPX Chorus	Chorus effect that uses a 3-phase LFO to add modulation and spaciousness to the sound.
Symphonic	Multiplexes the modulations for creating more spaciousness.
Ensemble Detune	Chorus effect without modulation, created by adding a slightly pitch-shifted sound.

Flanger

VCM Flanger	Flanger using VCM technology
Classic Flanger	Flanger with typical swirling sounds
Tempo Flanger	Flanger with tempo synchronized LFO
Dynamic Flanger	Flanger that controls the delay modulation in real-time depending on the level of the input sound.
Control Flanger	Allows manual operation instead of the LFO.

Phaser

VCM Phaser Mono	Mono Phaser using VCM technology
VCM Phaser Stereo	Stereo Phaser using VCM technology
Tempo Phaser	Phaser with tempo synchronized LFO
Dynamic Phaser	Effect that controls the phase in real-time depending on the level of the input sound.
Control Phaser	Allows manual operation instead of the LFO.

Trem/Rtr (Tremolo & Rotary)

Auto Pan	Moves the Pan left and right.
Tremolo	Creates cyclical changes to the volume.
Rotary Speaker 1	Simulates a rotary speaker.
Rotary Speaker 2	Simulates a rotary speaker including an amplifier.
VCM Rotary Speaker Classic	Standard rotary speaker effect using VCM technology. Suitable for organs.
VCM Rotary Speaker Overdrive	Rotary speaker effect using VCM technology. Simulates the distorted sound of a rotary speaker with a transistor preamp connected.
VCM Rotary Speaker Studio	Rotary speaker effect using VCM technology, with three-dimensional rotation.

Dist (Distortion)

Amp Simulator 1	Simulates a guitar amplifier.
Amp Simulator 2	Simulates a guitar amplifier.
Comp Distortion	Combines Compressor and Distortion.
Comp Distortion Delay	Combines Compressor, Distortion, and Delay.
U.S. Combo	American combo amp simulator
Jazz Combo	Jazz combo amp simulator
U.S. High Gain	American high gain amp simulator
British Lead	British stack amp simulator
Multi FX	Multi-effect processor for guitars
Small Stereo	Stereo distortion for guitar sounds
British Combo	British combo amp simulator
British Legend	British stack amp simulator

Comp (Compressor)

VCM Compressor 376	Compressor using VCM technology
Classic Compressor	Simple, easy-to-use compressor. Suitable for solo instruments.
Multi-band Comp	Splits the sound into three bands and applies compressor separately on those bands.
Uni Comp Down	Compressor with a downward algorithm that suppresses loud sounds.
Uni Comp Up	Compressor with an upward algorithm that amplifies soft sounds.
Parallel Comp	Compressor applying parallel processing of the compressed sounds and dry sounds

Wah

VCM Auto Wah	Auto Wah using VCM technology. Creates cyclical changes to the center frequency of the filter.
VCM Touch Wah	Touch Wah using VCM technology. Changes the center frequency of the filter depending on the level of the input sound.
VCM Pedal Wah	Pedal Wah using VCM technology. Changes the center frequency of the filter by operating controllers, such as a pedal.

Lo-Fi

Lo-Fi	Downgrades the quality of the audio input for a lo-fi sound.
Noisy	Adds noise to the sound.
Digital Turntable	Adds turntable noise to the sound.
Bit Crusher	Produces distortion by reducing the resolution or bandwidth of the digital sound.

Tech

Ring Modulator	Changes the input to a metallic sound.
Dynamic Ring Modulator	The OSC Freq parameter for the Ring Modulator is controlled in real-time depending on the level of the input sound.
Dynamic Filter	The filter cutoff frequency is controlled in real-time depending on the level of the input sound.
Auto Synth	Resynthesizes the input signal using delay and modulation.
Spiralizer P	Special phaser-based filter with seemingly endless up or down pitch changes.
Tempo Spiralizer P	Spiralizer with tempo synchronized LFO
Spiralizer F	Special flanger-based filter with seemingly endless up or down pitch changes.
Tempo Spiralizer F	Spiralizer with tempo synchronized LFO
Isolator	Controls the volume of each band by using a powerful filter.
Slice	Slices the Amplitude EG of the input sound.
Tech Modulation	Applies special modulation.
Control Filter	A filter that allows manual operation of the cutoff frequency.
Vinyl Break	Causes the pitch to drop gradually to create a sound effect of a turntable stopped by hand or turning the device off.
Beat Repeat (even)	Creates mechanical beats by repeatedly playing sampled sounds. The length of the repeat is specified as a fraction of a beat with a denominator of an even number, such as 1/2, 1/4, 1/8, 1/16, and so on.
Beat Repeat (triplet)	Creates mechanical beats by repeatedly playing sampled sounds. The length of the repeat is specified as a fraction of a beat with a denominator having multiples of three, such as 1/3, 1/6, 1/12, and so on.
Beat Repeat (even+tri.)	Creates mechanical beats by repeatedly playing sampled sounds. Contains both even and triplet settings.
Beat Repeat (free)	Creates mechanical beats by repeatedly playing sampled sounds. The length of the repeat is specified as a decimal number.

Misc

VCM EQ 501	5-band EQ using VCM technology
Presence	Gives greater sonic presence to the input sound.
Harmonic Enhancer	Adds harmonic overtones to make the input sound stand out.
Stereophonic Optimizer	Adjusts the stereo location in the sound field.
Talking Modulator	Resynthesizes the input sound to create vowel formants.
Wave Folder	Controls the harmonic overtones to create a rich sound that changes over time.
VCM Mini Filter	Filter that adds thickness and depth to the sound. Simulates analog synthesizer circuitry.
VCM Mini Booster	Booster with distinctive characteristics. Simulates analog synthesizer circuitry.
Damper Resonance	Simulates the resonance of open string notes of an acoustic piano.
Pitch Change	Changes the pitch of the input sound.
Early Reflection	An effect created by isolating the early reflections of the reverb.
Vocoder	Extracts characteristics from the microphone sound and applies it to the Part played on the keyboard. The instrument's sound changes to sound like a robot's voice.
NoiseGate+Comp+Eq	Contains Noise Gate, Compressor, and 3-band EQ. Suitable mainly for vocals.

Effect parameters

A

Display name	Parameter name	Effect types using the parameter	Description
AEG Phase	AEG Phase	Slice	Shifts the phase of the Amplitude EG.
AM Depth	AM Depth	2 Modulator, Tremolo, Noisy, Auto Synth, Shimmer Reverb	Sets the depth of Amplitude Modulation.
AM Freq	AM Frequency	Shimmer Reverb	Sets the Amplitude Modulation speed.
AM Inverse R	AM Inverse R	Auto Synth	Sets the phase of the Amplitude Modulation for the right channel.
AM LR Phase	AM LR Phase	Shimmer Reverb	Sets the phase of the Amplitude Modulation between the L and R channels.
AM Speed	AM Speed	Noisy, Auto Synth	Sets the Amplitude Modulation speed.
AM Wave	AM Wave	Auto Synth	Selects the wave for modulating the Amplitude.
AM Waveform	AM Waveforms	Shimmer Reverb	Selects the wave for modulating the Amplitude.
Amp Type	Amp Type	Amp Simulator 2	Selects the amplifier type to be simulated.
Analog Feel	Analog Feel	Classic Flanger	Adds the characteristics of an analog flanger to the sound.
Attack	Attack	Comp Distortion, VCM Compressor 376, Classic Compressor, Downward Compressor, Upward Compressor	Sets the length of time it takes for the compressor to reach the maximum.
Attack Offset	Attack Offset	VCM Touch Wah	Sets the length of time it takes for the Wah effect to be applied.
Attack Time	Attack Time	Dynamic Flanger, Dynamic Phaser, Dynamic Ring Modulator, Dynamic Filter	Sets the attack time of the Envelope Follower.
		Beat Repeat	Sets the Attack time of the Gate applied to the entire sound

B

Display name	Parameter name	Effect types using the parameter	Description
Balance	Balance	U.S. Combo	Adjusts the balance between the bass and the treble.
Bass	Bass	British Combo, British Lead, British Legend, Jazz Combo, U.S. High Gain	Adjusts the tone quality of the bass.
Bit	Bit	Bit Crusher	Reduces the bit precision.
Bit Assign	Bit Assign	Lo-Fi	Sets how Word Length is applied to the sound
Bit Link	Bit Link	Bit Crusher	Sets the level of the Side setting that follows the Mid value when M/S is on
BPF 1–10 Gain	BPF1–10 Gain	Vocoder	Sets the Gain of BPFs 1–10 of the Vocoder effect
Break	Break	Vinyl Break	Sets Break to On
Brilliant	Brilliant	British Combo	Adjusts the volume of the sound for which the bass is cut.

C

Display name	Parameter name	Effect types using the parameter	Description
Chorus	Chorus	Jazz Combo	Selects the Chorus type.
Click Density	Click Density	Digital Turntable	Sets the frequency of the click sound to be repeated.
Click Level	Click Level	Digital Turntable	Sets the click level.
Clipper	Clipper	Upward Compressor, Downward Compressor	Sets the distortion level of the Clipper that determines the maximum level for limiting the wave.
Clipper Source	Clipper Source	Upward Compressor, Downward Compressor	Selects the signal to which the Clipper effect is applied.
Color	Color	Control Phaser, VCM Phaser Mono, VCM Phaser Stereo	Sets the fixed phase modulation.
Com Release	Common Release	Multi Band Comp	Sets the Release Time (the time it takes for the Compressor effect to fade away) used commonly on three bands.
Comp Attack	Comp Attack	NoiseGate+Comp+Eq	Sets the length of time for the Compressor to be applied.
Comp Level	Comp Level	Small Stereo	Adjusts the output level of the compressor.
Comp Out Lvl	Comp Output Level	NoiseGate+Comp+Eq	Sets the output level of the compressor.
Comp Ratio	Comp Ratio	NoiseGate+Comp+Eq	Sets the ratio of the compressor.
Comp Release	Comp Release	NoiseGate+Comp+Eq	Sets the length of time it takes until the compressor effect fades away.
Comp Sustain	Comp Sustain	Multi FX, Small Stereo	Adjusts the length of time for the compressor to sustain.
Comp Sw	Comp SW	Small Stereo	Turns the compressor on or off.
Comp Threshold	Comp Threshold	NoiseGate+Comp+Eq	Sets the input level for the effect to be applied.
Compress	Compress	Comp Distortion Delay	Sets the threshold (or the minimum input level) for the compressor to be applied.
Compression	Compression	Parallel Compressor	Sets the extent to which the compressor is applied.
Control Type	Control Type	Control Delay	When set to Normal, the delay effect is always applied to the sound. When set to Scratch, the delay effect is not applied if the controller value 0 is set to the Delay Time. The delay is applied to other cases.
Cross-Feedback	Cross-Feedback	Shimmer Reverb	Sets the balance of the pitch-shifted sound on the first routing and the pitched sound on the second routing to be sent to the opposite routing for the feedback of the pitch-shifted sound
Crush Type	Crush Type	Bit Crusher	Sets how the bit precision is reduced.
Cut	Cut	British Combo	Sets the velocity curve to the end of the sound
Cutoff	Cutoff Frequency	Beat Repeat	Cuts the high frequencies.
		VCM Mini Filter	Sets the Cutoff Frequency of the Filter for the effect sound.
	Cutoff Frequency Control	Control Filter	Sets the Filter Cutoff Frequency.

D

Display name	Parameter name	Effect types using the parameter	Description
Damper Control	Damper Control	Damper Resonance	Sets the amount of resonance for the piano damper.
Decay	Decay	REV-X Hall, REV-X Room	Controls how the reverb sound decays.
Delay Control	Delay Control	Multi FX	Adjusts the depth or amount of the effect set to Delay Sw
Delay Input Lvl	Delay Input Level	Analog Delay Retro, Analog Delay Modern	Sets the input level to the delay.
Delay Level	Delay Level	Auto Synth	Sets the level of the delayed sound.
Delay Level C	Delay Level C	Delay LCR	Sets the level of the delayed sound for the center channel.
Delay Mix	Delay Mix	Comp Distortion Delay	Sets the mixing level of the delayed sound.
Delay Offset	Delay Offset	G Chorus, 2 Modulator, SPX Chorus, Symphonic, Classic Flanger, Tempo Flanger, Dynamic Flanger	Sets the offset value for the delay modulation.
Delay Sw	Delay SW	Multi FX	Sets the delay type or modulation type.
Delay Time	Delay Time	Tempo Delay Mono, Tempo Delay Stereo	Specifies the delay length in note duration.
Comp Ratio	Comp Ratio	Control Delay, Auto Synth, Tech Modulation, Multi FX, Analog Delay Retro, Analog Delay Modern	Sets the delay length.
Delay Time C	Delay Time C	Delay LCR	Sets the delay length for the center channel.
Delay Time L	Delay Time L	Delay LR, Delay LCR, Comp Distortion Delay	Sets the delay length for the left channel.
Delay Time L>R	Delay Time L>R	Cross Delay, Tempo Cross Delay	Sets the delay time for the sound that is input from the left to be output from the right.
Delay Time R	Delay Time R	Delay LR, Delay LCR, Comp Distortion Delay	Sets the delay length for the right channel.
Delay Time R>L	Delay Time R>L	Cross Delay, Tempo Cross Delay	Sets the delay time for the sound that is input from the right to be output from the left.
Delay Tm Ofs R	Delay Time Offset R	Auto Synth, Tech Modulation	Sets the offset to the delay length for the right channel.
Density	Density	R3 Hall, R3 Room, R3 Plate, SPX Hall, SPX Room, SPX Stage, Space Simulator	Sets the density of the reverb.
		Early Reflection, Gated Reverb, Reverse Reverb	Sets the density of the reflections.
Depth	Depth	Space Simulator	Sets the depth of the simulated room.
		VCM Flanger	Sets the Amplitude of the LFO wave that controls the cyclic change of the delay modulation.
		VCM Phaser Mono, VCM Phaser Stereo	Sets the Amplitude value of the LFO wave that controls the cyclic change of the phase modulation.
		Jazz Combo	Sets the depth of the Chorus/Vibrato.
Device	Device	Amp Simulator 1, Comp Distortion Delay	Sets the device for creating distortion sounds

Display name	Parameter name	Effect types using the parameter	Description
Diffusion	Diffusion	REV-X Hall, REV-X Room, R3 Hall, R3 Room, R3 Plate, SPX Hall, SPX Room, SPX Stage, Space Simulator, Gated Reverb, Reverse Reverb, Shimmer Reverb	Sets the spread of the reverb.
		Tempo Phaser, Early Reflection	Sets the spread of the selected effect.
Direction	Direction	Dynamic Flanger, Dynamic Phaser, VCM Touch Wah, VCM Pedal Wah, Dynamic Ring Modulator, Dynamic Filter	Sets the direction of the modulation controlled by the envelope follower.
		Tempo Spiralizer P, Tempo Spiralizer F	Sets the direction of the pitch shift.
Dist Drive	Dist Drive	Multi FX, Small Stereo	Controls the amount of distortion.
Dist EQ	Dist EQ	Multi FX, Small Stereo	Switches the EQ type for adjusting the tone quality of distortion.
Dist Presence	Dist Presence	Multi FX, Small Stereo	Adjusts the tone quality for each distortion type.
Dist Sw	Dist SW	Multi FX	Sets the distortion type.
Dist Tone	Dist Tone	Multi FX, Small Stereo	Adjusts the tone quality of distortion.
Dist Type	Dist Type	Small Stereo	Sets the distortion type.
Distortion	Distortion	Jazz Combo	Sets the level of distortion.
Divide Freq Hi	Divide Freq High	Multi Band Comp	Sets the Mid/High frequency to divide into three bands
Divide Freq Low	Divide Freq Low	Multi Band Comp	Sets the Low/Mid frequency to divide into three bands
Divide Min Lvl	Divide Min Level	Slice	Sets the minimum level of the sliced section.
Divide Type	Divide Type	Slice	Specifies the timing for slicing by note duration.
Drive	Drive	Noisy, Slice, Rotary Speaker 2, VCM Rotary Speaker Classic, VCM Rotary Speaker Overdrive, VCM Rotary Speaker Studio	Sets the level of distortion.
		Harmonic Enhancer, Talking Modulator	Sets the level of the effect.
Drive Horn	Drive Horn	Rotary Speaker 1	Sets the depth of modulation generated by the rotation of the horn (treble).
Drive Rotor	Drive Rotor	Rotary Speaker 1	Sets the depth of modulation generated by the rotation of the rotor (woofer).
Dry Level	Dry Level	Digital Turntable	Sets the level of the dry sound.
Dry LPF Cutoff	Dry LPF Cutoff Frequency	Digital Turntable	Sets the frequency to cut by using the Low-Pass Filter applied to the dry sound.
Dry Mix Level	Dry Mix Level	Auto Synth	Sets the level of the dry sound.
Dry/Wet	Dry/Wet Balance	All	Sets the balance of the dry sound and the effect sound.

E

Display name	Parameter name	Effect types using the parameter	Description
Edge	Edge	Comp Distortion	Sets the curve that determines how the sound is distorted.
Emphasis	Emphasis	Lo-Fi	Sets the change of the high frequency characteristics.
EQ 1 Freq	EQ1(LSH) Frequency	VCM EQ 501	Sets the cutoff frequency of EQ1 (Low Shelving)
EQ 1 Gain	EQ1(LSH) Gain	VCM EQ 501	Sets the gain of EQ1 (Low Shelving)
EQ 2 Freq	EQ2 Frequency	VCM EQ 501	Sets the center frequency of EQ2.
EQ 2 Gain	EQ2 Gain	VCM EQ 501	Sets the gain of EQ2.
EQ 2 Q	EQ2 Q	VCM EQ 501	Sets the Q of EQ2.
EQ 3 Freq	EQ3 Frequency	VCM EQ 501	Sets the center frequency of EQ3
EQ 3 Gain	EQ3 Gain	VCM EQ 501	Sets the gain of EQ3
EQ 3 Q	EQ3 Q	VCM EQ 501	Sets the Q of EQ3
EQ 4 Freq	EQ4 Frequency	VCM EQ 501	Sets the center frequency of EQ4
EQ 4 Gain	EQ4 Gain	VCM EQ 501	Sets the gain of EQ4
EQ 4 Q	EQ4 Q	VCM EQ 501	Sets the Q of EQ4
EQ 5 Freq	EQ5(HSH) Frequency	VCM EQ 501	Sets the cutoff frequency of EQ5 (High Shelving)
EQ 5 Gain	EQ5(HSH) Gain	VCM EQ 501	Sets the gain of EQ5 (High Shelving)
EQ Frequency	EQ Frequency	Noisy	Sets the frequency to boost or attenuate by using the EQ.
		VCM Mini Booster	Sets the frequency of the EQ set to Type
EQ Gain	EQ Gain	Noisy	Sets the gain to boost or attenuate by using the EQ.
EQ High Freq	EQ High Frequency	Cross Delay, Tempo Cross Delay, Tempo Delay Mono, Tempo Delay Stereo, Control Delay, Delay LR, Delay LCR, G Chorus, 2 Modulator, SPX Chorus, Symphonic, Ensemble Detune, Classic Flanger, Tempo Flanger, Dynamic Flanger, Tempo Phaser, Dynamic Phaser, Auto Pan, Tremolo, Rotary Speaker 1, Ring Modulator, Dynamic Ring Modulator, Dynamic Filter, Slice, HD Hall, HD Room, HD Plate, NoiseGate+Comp+Eq	Sets the frequency of the high band to boost or attenuate by using the EQ.
EQ High Gain	EQ High Gain	Cross Delay, Tempo Cross Delay, Tempo Delay Mono, Tempo Delay Stereo, Control Delay, Delay LR, Delay LCR, G Chorus, 2 Modulator, SPX, Chorus, Symphonic, Ensemble Detune, Classic Flanger, Tempo Flanger, Dynamic Flanger, Tempo Phaser, Dynamic Phaser, Auto Pan, Tremolo, Rotary Speaker 1, Ring Modulator, Dynamic Ring Modulator, Dynamic Filter, Slice, HD Hall, HD Room, HD Plate, NoiseGate+Comp+Eq	Sets the gain of the high band to boost or attenuate by using the EQ.

Display name	Parameter name	Effect types using the parameter	Description
EQ Low Freq	EQ Low Frequency	Cross Delay, Tempo Cross Delay, Tempo Delay Mono, Tempo Delay Stereo, Control Delay, Delay LR, Delay LCR, G Chorus, 2 Modulator, SPX Chorus, Symphonic, Ensemble Detune, Classic Flanger, Tempo Flanger, Dynamic Flanger, Tempo Phaser, Dynamic Phaser, Auto Pan, Tremolo, Rotary Speaker 1, Ring Modulator, Dynamic Ring Modulator, Dynamic Filter, Slice, Comp Distortion, HD Hall, HD Room, HD Plate	Sets the frequency of the low band to boost or attenuate by using the EQ.
EQ Low Gain	EQ Low Gain	Cross Delay, Tempo Cross Delay, Tempo Delay Mono, Tempo Delay Stereo, Control Delay, Delay LR, Delay LCR, G Chorus, 2 Modulator, SPX Chorus, Symphonic, Ensemble Detune, Classic Flanger, Tempo Flanger, Dynamic Flanger, Tempo Phaser, Dynamic Phaser, Auto Pan, Tremolo, Rotary Speaker 1, Ring Modulator, Dynamic Ring Modulator, Dynamic Filter, Slice, Comp Distortion, HD Hall, HD Room, HD Plate	Sets the gain of the low band to boost or attenuate by using the EQ.
EQ Mid Freq	EQ Mid Frequency	G Chorus, 2 Modulator, SPX Chorus, Symphonic, Classic Flanger, Tempo Flanger, Auto Pan, Tremolo, Comp Distortion, NoiseGate+Comp+EQ	Sets the frequency of the mid band to boost or attenuate by using the EQ.
EQ Mid Gain	EQ Mid Gain	G Chorus, 2 Modulator, SPX Chorus, Symphonic, Classic Flanger, Tempo Flanger, Auto Pan, Tremolo, Comp Distortion, NoiseGate+Comp+EQ	Sets the gain of the mid band to boost or attenuate by using the EQ.
EQ Mid Width	EQ Mid Width	G Chorus, 2 Modulator, SPX Chorus, Symphonic, Classic Flanger, Tempo Flanger, Auto Pan, Tremolo, Comp Distortion, NoiseGate+Comp+EQ	Sets the width of the middle band to boost or attenuate by using the EQ.
EQ Width	EQ Width	Noisy	Sets the width to boost or attenuate by using the EQ.
ER/Rev Balance	ER/Rev Balance	R3 Hall, R3 Room, R3 Plate, SPX Hall, SPX Room, SPX Stage, Space Simulator	Sets the level balance of the early reflection and reverb sounds.

F

Display name	Parameter name	Effect types using the parameter	Description
F/R Depth	F/R Depth	Auto Pan	Sets the depth of the pan on the front and rear (available when PAN Direction is set to L Turn or R Turn)
FB Hi Dmp Ofs R	FB Hi Damp Offset R	Tech Modulation	Sets the offset for the treble attenuation on the right channel
FB High Damp	Feedback High Damp	R3 Hall, R3 Room, R3 Plate, SPX Hall, SPX Room, SPX Stage, Space Simulator, Cross Delay, Tempo Cross Delay, Tempo Delay Mono, Tempo Delay Stereo, Control Delay, Delay LR, Delay LCR, Classic Flanger, Early Reflection, Gated Reverb, Reverse Reverb, Comp Distortion Delay, Tech Modulation	Adjusts the attenuation of high frequency sound by using the feedback sound. The smaller the value, the faster the attenuation of the high frequency sounds.
FB Level Ofs R	FB Level Offset R	Auto Synth, Tech Modulation	Sets the offset for the amount of feedback on the right channel
FB Time L	Feedback Time L	Delay LR	Sets the length of feedback for left delay
FB Time R	Feedback Time R	Delay LR	Sets the length of feedback for right delay
Feedback	Feedback	VCM Flanger, VCM Phaser Mono, VCM Phaser Stereo, Control Flanger, Control Phaser Spiralizer P, Spiralizer F, Tempo Spiralizer P, Tempo Spiralizer F	Sets the level of the output signal returned to the effect block.
Feedback	Feedback Level	R3 Hall, R3 Room, R3 Plate, SPX Hall, SPX Room, SPX Stage, Space Simulator, Early Reflection, Gated Reverb, Reverse Reverb	Sets the feedback level of the initial delay.
		Cross Delay, Tempo Cross Delay, Tempo Delay Mono, Tempo Delay Stereo, Control Delay, Delay LR, Delay LCR, G Chorus, 2 Modulator, SPX Chorus, Classic Flanger, Tempo Flanger, Dynamic Flanger, Comp Distortion Delay, Auto Synth, Teck Modulation	Sets the level of the delay sound to be sent back to the input (phase is inverted for negative values)
		Analog Delay Retro, Analog Delay Modern	Sets the feedback level of the delayed sound.
		Tempo Phaser, Dynamic Phaser	Sets the level of the signal output from the phaser and returned to the input (phase is inverted for negative values)
Feedback Lvl 1	Feedback Level 1	Pitch Change	Sets the feedback level of the delayed sound on the first routing
Feedback Lvl 2	Feedback Level 2	Pitch Change	Sets the feedback level of the delayed sound on the second routing
Feedback Time	Feedback Time	Delay LCR, Comp Distortion Delay	Sets the delay length of the feedback.
Filter Type	Filter Type	Lo-Fi	Selects the effect type.
		Dynamic Filter, Control Filter	Sets the filter Type.
		Beat Repeat	Sets the filter type for the effect sound.
Fine 1	Fine 1	Pitch Change, Shimmer Reverb	Fine-tunes the pitch on the first routing.

Display name	Parameter name	Effect types using the parameter	Description
Fine 2	Fine 2	Pitch Change, Shimmer Reverb	Fine-tunes the pitch on the second routing.
Flanger Control	Flanger Control	Control Flanger	Sets the delay value (the value of the Comb Filter of the delay modulation)
Fold	Fold	Wave Folder	Distorts the sound.
Fold Type	Fold Type	Wave Folder	Selects the level of distortion.
Formant Offset	Formant Offset	Vocoder	Adds the offset value to the Cutoff Frequency of the BPF for the input of the instrument sound.
Formant Shift	Formant Shift	Vocoder	Shifts the Cutoff Frequency of each BPF for the input of the instrument sound.
Freeze	Freeze	Beat Repeat	When this parameter is set to On, the beat is repeated.

G

Display name	Parameter name	Effect types using the parameter	Description
Gain	Gain	U.S. High Gain	Sets the gain of the preamplifier.
		VCM Mini Booster	Adjusts the Gain of the ShelfEQ
Gain Boost	Gain Boost	U.S. Combo	Switches the gain of the power amplifier.
Gain Limit	Gain Limit	Upward Compressor	Sets the maximum Gain level
Gate Time	Gate Time	Slice	Sets the gate time of a slice.
		Beat Repeat	Sets the Gate time of the entire sound

H

Display name	Parameter name	Effect types using the parameter	Description
Height	Height	Space Simulator	Sets the height of the simulated room.
Hi Damp Freq	High Damp Frequency	HD Hall, HD Room, HD Plate	Adjusts the attenuation of the high band.
High Attack	High Attack	Multi Band Comp	Sets the length of time for the compressor to be applied to the high band
High Cut	High Cut	U.S. Combo	Cuts the high band.
High Gain	High Gain	Multi Band Comp	Sets the output level for the high band
High Gain L	High Subband Gain Lch	Stereophonic Optimizer	Sets the resultant gain of the High band after the adjustment of the stereo sound (L channel)
High Gain R	High Subband Gain Rch	Stereophonic Optimizer	Sets the resultant gain of the High band after the adjustment of the stereo sound (R channel)
High Level	High Level	Isolator	Sets the level of the high band.
High Mute	High Mute	Isolator	Switches the mute for the high band.
High Ratio	High Ratio	REV-X Hall, REV-X Room, HD Hall, HD Room, HD Plate	Adjusts the ratio of the high frequencies.
		Multi Band Comp	Sets the compression ratio for the high band
High Threshold	High Threshold	Multi Band Comp	Sets the minimum input level for the effect to be applied to the high band
High Treble	High Treble	Jazz Combo	Adjusts the tone quality in the frequency higher than the Treble setting

Display name	Parameter name	Effect types using the parameter	Description
Horn Accel	Horn Acceleration	Rotary Speaker 2, VCM Rotary Speaker Classic, VCM Rotary Speaker Overdrive, VCM Rotary Speaker Studio	Sets how the rotation of the horn (treble) changes from Slow to Fast
Horn Decel	Horn Deceleration	Rotary Speaker 2, VCM Rotary Speaker Classic, VCM Rotary Speaker Overdrive, VCM Rotary Speaker Studio	Sets how the rotation of the horn (treble) changes from Fast to Slow
Horn Fast	Horn Speed Fast	Rotary Speaker 1, Rotary Speaker 2, VCM Rotary Speaker Classic, VCM Rotary Speaker Overdrive, VCM Rotary Speaker Studio	Sets the rotation speed of the horn (treble) for the Fast setting
Horn Level	Horn Level	VCM Rotary Speaker Classic, VCM Rotary Speaker Overdrive, VCM Rotary Speaker Studio	Sets the volume of the horn (treble).
Horn Slow	Horn Speed Slow	Rotary Speaker 1, Rotary Speaker 2, VCM Rotary Speaker Classic, VCM Rotary Speaker Overdrive, VCM Rotary Speaker Studio	Sets the rotation speed of the horn (treble) for the Slow setting
Horn Slow/Fast	Horn Slow/Fast Time	Rotary Speaker 1	Sets the transition time for the rotation speed of the horn (treble) to change from Slow to Fast
HPF Cutoff	HPF Cutoff Frequency	REV-X Hall, REV-X Room, R3 Hall, R3 Room, R3 Plate, SPX Hall, SPX Room, SPX Stage, Space Simulator, Ring Modulator, Dynamic Ring Modulator, Auto Synth, Harmonic Enhancer, Early Reflection, Gated Reverb, Reverse Reverb	Sets the low frequency to cut by using the HPF
		Vocoder	Sets the Cutoff Frequency of the High-Pass Filter applied to the sound input from the microphone.
HPF Output Lvl	HPF Output Level	Vocoder	Sets how much the output from High-Pass Filter is mixed with the output from the Vocoder.

I

Display name	Parameter name	Effect types using the parameter	Description
Initial Delay	Initial Delay	REV-X Hall, REV-X Room, R3 Hall, R3 Room, R3 Plate, SPX Hall, SPX Room, SPX Stage, Space Simulator, Early Reflection, HD Hall, HD Room, HD Plate, Gated Reverb, Reverse Reverb	Sets the delay time for the early reflections.
Initial Delay 1	Initial Delay 1	Pitch Change	Sets the delay length of the first series of effects.
Initial Delay 2	Initial Delay 2	Pitch Change	Sets the delay length of the second series of effects.
Initial Delay L	Initial Delay Lch	Ensemble Detune	Sets the length of the left channel delay.
Initial Delay R	Initial Delay Rch	Ensemble Detune	Sets the length of the right channel delay.
Input Level	Input Level	Bit Crusher, VCM Compressor 376, Rotary Speaker 2, Parallel Compressor, Wave Folder, VCM Mini Filter, VCM Mini Booster	Sets the input level.
Input Mode	Input Mode	G Chorus, 2 Modulator, SPX Chorus, Auto Pan, Tremolo, Lo-Fi	Selects whether the input sound is in mono or stereo.
Input Select	Input Select	Cross Delay, Tempo Cross Delay	Selects an input.
Inst Level	Inst Level	Vocoder	Sets the input level of the Instrument sound.

K

Display name	Parameter name	Effect types using the parameter	Description
Knee	Knee	Upward Compressor, Downward Compressor	Sets the curve around the Threshold. The higher the value, the shallower the curve.

L

Display name	Parameter name	Effect types using the parameter	Description
L/R Depth	L/R Depth	Auto Pan	Sets the depth of the left and right pan.
L/R Diffusion	L/R Diffusion	Tempo Delay Mono, Tempo Delay Stereo	Sets the difference of the delay on the right and left for creating spaciousness.
Lag	Lag	Tempo Cross Delay, Tempo Delay Mono, Tempo Delay Stereo	Sets an additional delay length applied to the delayed sound specified by a note duration.
Length	Length	Beat Repeat	Sets the length for a repeat.
Level Offset	Dyna Level Offset	Dynamic Flanger, Dynamic Phaser, Dynamic Ring Modulator, Dynamic Filter	Sets the offset value added to the output of the envelope follower.
LFO Depth	LFO Depth	SPX Chorus, Symphonic, Classic Flanger, Tempo Flanger, Ring Modulator	Sets the depth of the modulation.
		Tempo Phaser	Sets the depth of the phase modulation.
		Wave Folder	Adjusts the depth of the LFO effect.
LFO Shape	LFO Shape	Wave Folder	Adjusts the shape of the LFO.

Display name	Parameter name	Effect types using the parameter	Description
LFO Speed	LFO Speed	G Chorus, 2 Modulator, SPX Chorus, Symphonic, Classic Flanger, Tremolo, Ring Modulator, Multi FX	Sets the frequency of the modulation.
		Tempo Flanger, Tempo Phaser	Specifies the modulation speed by note duration.
		Auto Pan	Sets the frequency of the Auto Pan.
		Wave Folder	Adjusts the LFO speed.
LFO Wave	LFO Wave	Classic Flanger, Ring Modulator	Selects the wave for modulation.
		Auto Pan	Sets the panning curve.
		VCM Auto Wah	Selects the wave: sine or square.
Liveness	Liveness	Gated Reverb, Reverse Reverb, Early Reflection	Sets the attenuation of the early reflections.
Ln Chg Quantz	Length Change Quantize	Beat Repeat	Quantizes the timing for changing the Length parameter.
Low Attack	Low Attack	Multi Band Comp	Sets the length of time for the compressor to be applied to the low band
Low Cut	Low Cut	U.S. Combo	Cuts the low band.
Low Gain	Low Gain	Multi Band Comp	Sets the output level for the low band
Low Gain L	Low Subband Gain Lch	Stereophonic Optimizer	Sets the resultant gain of the Low band after the adjustment of the stereo sound (L channel)
Low Gain R	Low Subband Gain Rch	Stereophonic Optimizer	Sets the resultant gain of the Low band after the adjustment of the stereo sound (R channel)
Low Level	Low Level	Isolator	Sets the level for the low band.
Low Mute	Low Mute	Isolator	Switches the mute for the low band.
Low Ratio	Low Ratio	REV-X Hall, REV-X Room	Sets the adjustment of the low frequencies.
		Multi Band Comp	Sets the compression ratio for the low band
Low Threshold	Low Threshold	Multi Band Comp	Sets the minimum input level for the effect to be applied to the low band
Lower Range	Lower Range	VCM Auto Wah, VCM Touch Wah, VCM Pedal Wah	Sets the maximum value for the variable range of the Wah filter.
		Control Flanger	Sets the maximum value for the variable range of the Flanger Control
		Control Phaser	Sets the maximum value for the variable range of the Phase Control
LPF Cutoff	LPF Cutoff Frequency	REV-X Hall, REV-X Room, R3 Hall, R3 Room, R3 Plate, SPX Hall, SPX Room, SPX Stage, Space Simulator, Amp Simulator 2, Comp Distortion, Noisy, Ring Modulator, Dynamic Ring Modulator, Auto Synth, Early Reflection, Gated Reverb, Reverse Reverb, Auto Synth, Noisy	Sets the high frequency range cut by the Low-Pass Filter.
LPF Resonance	LPF Resonance	Noisy	Adds characteristics to the input to the Low-Pass Filter.

M

Display name	Parameter name	Effect types using the parameter	Description
M/S	M/S	Bit Crusher	When this parameter is on, each sound located at the center, left, and right changes individually.
Make Up Gain	Make Up Gain	Upward Compressor, Downward Compressor	Adjusts the level of the signal output from the compressor.
Manual	Manual	VCM Flanger	Sets the offset value of the delay modulation.
		VCM Phaser Mono, VCM Phaser Stereo	Sets the offset value of the phase modulation.
Master Volume	Master Volume	U.S. High Gain, British Lead, British Legend	Adjusts the gain of the power amplifier.
Mic Input Level	Mic Input Level	Vocoder	Sets the input level of the microphone
Mic L-R Angle	Mic L-R Angle	Rotary Speaker 1, Rotary Speaker 2, VCM Rotary Speaker Classic, VCM Rotary Speaker Overdrive, VCM Rotary Speaker Studio	Sets the L/R angle of the microphone for extracting sound from the output
Mic Out Gate	Mic Output Gate Switch	Vocoder	Off: Always passes HPF output and Noise Generator output On: Passes HPF output and Noise Generator output when there is audio input of the Instrument sound
Mic Position	Mic Position	U.S. Combo, Jazz Combo, U.S. High Gain, British Lead, British Combo, British Legend, Rotary Speaker 2	Sets the relative position of the microphone to the speaker.
Mid	Middle	British Lead, British Legend, Jazz Combo, U.S. High Gain	Sets the tone quality of the mid band.
Mid 1 Gain L	Mid1 Subband Gain Lch	Stereophonic Optimizer	Sets the resultant gain of the Mid1 band after the adjustment of the stereo sound (L channel)
Mid 1 Gain R	Mid1 Subband Gain Rch	Stereophonic Optimizer	Sets the resultant gain of the Mid1 band after the adjustment of the stereo sound (R channel)
Mid 2 Gain L	Mid2 Subband Gain Lch	Stereophonic Optimizer	Sets the resultant gain of the Mid2 band after the adjustment of the stereo sound (L channel)
Mid 2 Gain R	Mid2 Subband Gain Rch	Stereophonic Optimizer	Sets the resultant gain of the Mid2 band after the adjustment of the stereo sound (R channel)
Mid 3 Gain L	Mid3 Subband Gain Lch	Stereophonic Optimizer	Sets the resultant gain of the Mid3 band after the adjustment of the stereo sound (L channel)
Mid 3 Gain R	Mid3 Subband Gain Rch	Stereophonic Optimizer	Sets the resultant gain of the Mid3 band after the adjustment of the stereo sound (R channel)
Mid Attack	Mid Attack	Multi Band Comp	Sets the length of time for the compressor to be applied to the mid band
Mid Cut	Mid Cut	U.S. Combo	Cuts the mid frequencies.
Mid Gain	Mid Gain	Multi Band Comp	Sets the output level for the mid band
Mid Level	Mid Level	Isolator	Sets the level for the mid frequencies.
Mid Mute	Mid Mute	Isolator	Switches the mute for the mid frequencies.
Mid Ratio	Mid Ratio	Multi Band Comp	Sets the compression ratio for the mid band

Display name	Parameter name	Effect types using the parameter	Description
Mid Sweep	Mid Sweep	U.S. Combo	Adjusts the frequency range over which the mid frequencies are cut.
Mid Threshold	Mid Threshold	Multi Band Comp	Sets the minimum input level for the effect to be applied to the mid band
Mid Width	Mid Width	U.S. Combo	Sets the bandwidth to cut the mid frequencies.
Mix	Mix	VCM Flanger, Control Flanger	Sets the volume of the effect sound.
Mix Level	Mix Level	Harmonic Enhancer	Sets the level of the effect sound mixed with the dry sound.
Mod Depth	Mod Depth	Noisy, Auto Synth, Tech Modulation, Shimmer Reverb	Sets the depth of the modulation.
	Modulation Depth	Rotary Speaker 2	Sets the depth of cyclical changes in the volume.
Mod Dpt Ofs R	Mod Depth Offset R	Auto Synth	Sets the offset to the depth of the modulation for the R channel.
Mod Feedback	Mod Feedback	Noisy	Sets the level of feedback to the modulation.
Mod Gain	Mod Gain	Tech Modulation	Sets the gain level of the modulation.
Mod LPF Cutoff	Mod LPF Cutoff Frequency	Tech Modulation	Sets the Cutoff Frequency of the Low-Pass Filter applied to the modulated sound.
Mod LPF Res	Mod LPF Resonance	Tech Modulation	Adds characteristics to the modulated sound by using the Low-Pass Filter.
Mod Mix	Mod Mix Balance	Noisy, Tech Modulation	Sets the mix balance of the modulated sound.
Mod Phase	Modulation Phase	Classic Flanger	Sets the L/R phase difference of the modulated wave.
Mod Speed	Mod Speed	Noisy, Auto Synth, Tech Modulation, Shimmer Reverb	Sets the modulation speed.
Mod Wave Type	Mod Wave Type	Auto Synth	Selects the wave type for modulation.
Mode	Mode	VCM Phaser Mono, VCM Phaser Stereo, Control Phaser	Sets an element for changing the phaser type, or more specifically, the factor for forming the phaser effect.
		British Combo	Switches the preamplifier.
Modulator Lvl	Modulator Input Level	Ring Modulator	Sets the modulator level.
Move Speed	Move Speed	Talking Modulator	Sets how long it takes to change to the sound specified by the Vowel parameter

N

Display name	Parameter name	Effect types using the parameter	Description
Noise Level	Background Noise Level	VCM Rotary Speaker Classic, VCM Rotary Speaker Overdrive, VCM Rotary Speaker Studio	Sets the amount of background noise.
	Noise Level	Vocoder	Sets the level of the noise input.
		Digital Turntable	Sets the noise level.
Noise LPF Q	Noise LPF Q	Digital Turntable	Sets the Resonance of the Low-Pass Filter applied to the noise.
Noise Switch	Background Noise Off/On	VCM Rotary Speaker Classic, VCM Rotary Speaker Overdrive, VCM Rotary Speaker Studio	Turns the background noise on or off.
Noise Tone	Noise Tone	Digital Turntable	Sets the tone quality of the noise.

Display name	Parameter name	Effect types using the parameter	Description
Normal	Normal	British Combo	Adjusts the volume of the sound with flat EQ response.
Ns Gate Atk	Noise Gate Attack	NoiseGate+Comp+Eq	Sets the length of time for the Noise Gate to be applied.
Ns Gate Rls	Noise Gate Release	NoiseGate+Comp+Eq	Sets the length of time for the Noise Gate to be inactive.
Ns Gate Thrs	Noise Gate Threshold	NoiseGate+Comp+Eq	Sets the minimum input level for the Noise Gate to be applied.
Ns LPF Cutoff	Noise LPF Cutoff Frequency	Digital Turntable	Sets the frequency to cut by using the Low-Pass Filter applied to the noise.
Ns Mod Depth	Noise Mod Depth	Digital Turntable	Sets the depth of the noise modulation.
Ns Mod Speed	Noise Mod Speed	Digital Turntable	Sets the speed of the noise modulation.

O

Display name	Parameter name	Effect types using the parameter	Description
Offset	Filter Offset	Spiralizer P, Spiralizer F, Tempo Spiralizer P, Tempo Spiralizer F	Sets the initial pitch value in semitones.
Ofs Transition	Offset Transition Rate	Spiralizer P, Spiralizer F, Tempo Spiralizer P, Tempo Spiralizer F	Sets the transition time for the Offset value to change to the new value.
On/Off Switch	On/Off Switch	Isolator	Turns the isolator on or off.
		Stereophonic Optimizer	Turns the effect on or off.
Osc Freq	OSC Frequency Coarse	Ring Modulator	Sets the frequency for modulating the input wave.
Osc Freq Fine	OSC Frequency Fine	Ring Modulator	Finely adjusts the frequency for modulating the input wave.
Output	Output	VCM Auto Wah, VCM Touch Wah, VCM Pedal Wah	Sets the output level.
Output Level	Filter Output Level	Control Filter	Sets the output level of the filter.
	Output Level	Amp Simulator 1, Amp Simulator 2, Comp Distortion, Comp Distortion Delay, U.S. Combo, Jazz Combo, U.S. High Gain, British Combo, British Lead, British Legend, Multi FX, Small Stereo, VCM Compressor 376, Classic Compressor, VCM EQ 501, Talking Modulator, Lo-Fi, Bit Crusher, Vinyl Break, Beat Repeat, Rotary Speaker 2, Downward Compressor, Upward Compressor, Parallel Compressor, Presence, Wave Folder, VCM Mini Filter, VCM Mini Booster	Sets the output level.
		Vocoder	Sets the output level of the Vocoder.
Output Level 1	Output Level1	Pitch Change	Sets the output level on the first routing.
Output Level 2	Output Level2	Pitch Change	Sets the output level on the second routing.
Overdrive	Overdrive	Amp Simulator 1, Amp Simulator 2, Comp Distortion, Comp Distortion Delay, VCM Auto Wah, VCM Touch Wah, VCM Pedal Wah	Sets the level of distortion.

P

Display name	Parameter name	Effect types using the parameter	Description
Pan 1	Pan 1	Pitch Change	Sets the pan on the first routing.
Pan 2	Pan 2	Pitch Change	Sets the pan on the second routing.
Pan AEG Min Lvl	Pan AEG Min Level	Slice	Sets the minimum level of the Amplitude EG applied to the panned sound.
Pan AEG Type	Pan AEG Type	Slice	Sets the type of Amplitude EG applied to the panned sound.
Pan Depth	Pan Depth	Slice	Sets the depth of the pan.
Pan Direction	Pan Direction	Auto Pan	Sets the Auto Pan type.
Pan Type	Pan Type	Slice	Sets the pan type.
Panning	Panning	Jazz Combo	Sets the spread of the Chorus/Vibrato.
Pedal Control	Pedal Control	VCM Pedal Wah	Controls the Cutoff Frequency of the Wah filter.
Phase Control	Phase Control	Control Phaser	Sets the depth of the phase modulation.
Phase Differ	LFO Phase Difference	Tempo Flanger, Tremolo	Sets the L/R phase difference of the modulated wave. (No phase difference for 0 deg or the value 64.)
Phase Reset	LFO Phase Reset	Tempo Flanger, Tempo Phaser, Slice	Sets how the initial phase of the LFO is reset.
Phase Shift Ofs	Phase Shift Offset	Tempo Phaser	Sets the offset value of the phase modulation.
Phaser Sw	Phaser SW	Multi FX	Sets the Phaser type.
Pitch 1	Pitch 1	Pitch Change, Shimmer Reverb	Sets the pitch for the first routing in semitones.
Pitch 2	Pitch 2	Pitch Change, Shimmer Reverb	Sets the pitch for the second routing in semitones.
P1/P2 Balance	Pitch 1/Pitch 2 Balance	Shimmer Reverb	Sets the volume balance of the pitch-shifted sound on the first routing and the pitch-shifted sound on the second routing.
P1&P2 Dly Ofs	Pitch 1 & Pitch 2 Delay Offset	Shimmer Reverb	Sets the delay offset value for the pitch-shifted sound on the first routing and the pitch-shifted sound on the second routing.
P1&P2 Panning	Pitch 1/Pitch 2 Panning	Shimmer Reverb	Sets the pan for the pitch-shifted sound on the first routing and the pitch-shifted sound on the second routing.
Pitch Sweep	Pitch Sweep	Beat Repeat	Sets the pitch to change gradually in each repetition.
Plate Type	Plate Type	HD Plate	Sets how the sound resonates.
Play Speed	Play Speed	Beat Repeat	Sets the playback speed.
PM Depth	PM Depth	G Chorus, 2 Modulator, Tremolo	Sets the depth of the pitch modulation.
Post-comp HPF	Post-comp HPF	Upward Compressor, Downward Compressor	Sets the Cutoff Frequency of the High-Pass Filter which follows the compressor.
Pre Mod HPF F	Pre Mod HPF Cutoff Frequency	Tech Modulation	Sets the Cutoff Frequency of the High-Pass Filter before modulation is applied.
Preamp	Preamp	British Lead	Sets the gain of the preamplifier.
Pre-Delay	Pre-Delay	Shimmer Reverb	Sets the delay time for the early reflections.
Pre-LPF Cutoff	Pre-LPF Cutoff Frequency	Lo-Fi	Sets the Cutoff Frequency of the Low-Pass Filter for cutting the high frequency.
Pre-LPF Res	Pre-LPF Resonance	Lo-Fi	Adds characteristics to the input to the Low-Pass Filter.
Presence	Presence	Presence	Sets the level of the effect.
		Amp Simulator 1, Comp Distortion Delay U.S. Combo, U.S. Hi Gain, British Lead, British Legend	Boosts the high frequencies.

R

Display name	Parameter name	Effect types using the parameter	Description
R/H Balance	Rotor/Horn Balance	Rotary Speaker 1, Rotary Speaker 2	Sets the volume balance of the horn (treble) and rotor (woofer).
Random	Random	Beat Repeat	Creates random repetition.
Ratio	Ratio	Comp Distortion, VCM Compressor 376, Classic Compressor, Downward Compressor, Upward Compressor	Sets the ratio of the compressor.
Release	Release	Comp Distortion, VCM Compressor 376, Classic Compressor, Downward Compressor, Upward Compressor	Sets the length of time it takes until the compressor effect fades away.
Release Curve	Release Curve	Dynamic Flanger, Dynamic Phaser, Dynamic Ring Modulator, Dynamic Filter	Sets the release curve of the envelope follower.
Release Time	Release Time	Dynamic Flanger, Dynamic Phaser, Dynamic Ring Modulator, Dynamic Filter	Sets the release time of the envelope follower.
		Beat Repeat	Sets the Release time of the Gate applied to the entire sound
Repeat	Repeat	Beat Repeat	Sets the Repeat on or off.
Resonance	Resonance	Dynamic Filter, Control Filter, VCM Mini Filter, VCM Mini Booster	Adds characteristics to the filter.
		Beat Repeat	Sets the Resonance of the filter for the effect sound.
Resonance Ofs	Resonance Offset	VCM Auto Wah, VCM Touch Wah, VCM Pedal Wah	Sets the offset value to the Resonance.
Retrigger Cycle	Retrigger Cycle	Beat Repeat	Sets the cycle for retriggering the Repeat
Reverb Delay	Reverb Delay	R3 Hall, R3 Room, R3 Plate, SPX Hall, SPX Room, SPX Stage, Space Simulator	Sets the delay time from the early reflections to the reverb.
Reverb Time	Reverb Time	REV-X Hall, REV-X Room, R3 Hall, R3 Room, R3 Plate, SPX Hall, SPX Room, SPX Stage, Space Simulator, HD Hall, HD Room, HD Plate	Sets the reverb length.
Room Size	Room Size	REV-X Hall, REV-X Room, Early Reflection, HD Hall, HD Room, Gated Reverb, Reverse Reverb	Sets the size of the room.
Rotor Accel	Rotor Acceleration	Rotary Speaker 2, VCM Rotary Speaker Classic, VCM Rotary Speaker Overdrive, VCM Rotary Speaker Studio	Sets the rotation speed of the rotor (woofer) to change from Slow to Fast
Rotor Decel	Rotor Deceleration	Rotary Speaker 2, VCM Rotary Speaker Classic, VCM Rotary Speaker Overdrive, VCM Rotary Speaker Studio	Sets the rotation speed of the rotor (woofer) to change from Fast to Slow
Rotor Fast	Rotor Speed Fast	Rotary Speaker 1, Rotary Speaker 2, VCM Rotary Speaker Classic, VCM Rotary Speaker Overdrive, VCM Rotary Speaker Studio	Sets the rotation speed of the rotor (woofer) for the Fast setting

Display name	Parameter name	Effect types using the parameter	Description
Rotor Level	Rotor Level	VCM Rotary Speaker Classic, VCM Rotary Speaker Overdrive, VCM Rotary Speaker Studio	Sets the volume of the rotor (woofer).
Rotor Slow	Rotor Speed Slow	Rotary Speaker 1, Rotary Speaker 2, VCM Rotary Speaker Classic, VCM Rotary Speaker Overdrive, VCM Rotary Speaker Studio	Sets the rotation speed of the rotor (woofer) for the Slow setting
Rotor Slow/Fast	Rotor Slow/Fast Time	Rotary Speaker 1	Sets the transition time for the rotation speed of the rotor (woofer) to change from Slow to Fast
Rtg Attack T	Retrigger Attack Time	Beat Repeat	Sets the Attack time of the Gate applied to the entire sound
Rtg Gate Time	Retrigger Gate Time	Beat Repeat	Sets the Gate time of the entire sound
Rtg Quantize	Retrigger Quantize	Beat Repeat	When this parameter is set to On, the sound is repeated at the beginning of the measure set in the built-in sequencer.
Rtg Release T	Retrigger Release Time	Beat Repeat	Sets the Release time of the Gate applied to the entire sound

S

Display name	Parameter name	Effect types using the parameter	Description
Sample Rate	Sample Rate	Bit Crusher	Lowers the Sample Rate
Sampling Freq	Sampling Frequency Control	Lo-Fi	Controls the sampling frequency.
SC EQ Freq	Side Chain EQ Frequency	Downward Compressor, Upward Compressor	Sets the frequency of the EQ used for detecting the compressor level.
SC EQ Gain	Side Chain EQ Gain	Downward Compressor, Upward Compressor	Sets the gain of the EQ used for detecting the compressor level.
SC EQ Q	Side Chain EQ Q	Downward Compressor, Upward Compressor	Sets the Q of the EQ used for detecting the compressor level.
Scale Type	Spiral Step Scale Type	Spiralizer P, Spiralizer F, Tempo Spiralizer P, Tempo Spiralizer F	Sets how to create changes when the Step Mode is set to Scale
Semitones	Spiral Step Semitones	Spiralizer P, Spiralizer F, Tempo Spiralizer P, Tempo Spiralizer F	Specifies the variation width in semitones when the Step Mode is set to Semitone
Send to Noise	Dry Send to Noise	Digital Turntable	Sets the level of the dry signal sent to the noise effect.
Sensitivity	Sensitivity	Dynamic Flanger, Dynamic Phaser, Dynamic Ring Modulator, Dynamic Filter	Sets the sensitivity of the modulation applied to the input change.
		VCM Touch Wah	Sets the sensitivity of the Wah filter's change applied to the input change.
SEQ Clock	SEQ Clock	Wave Folder	Adjusts the speed of the built-in sequencer.
SEQ Depth	SEQ Depth	Wave Folder	Adjusts the depth of the effect on the built-in sequencer.
SEQ Pattern	SEQ Pattern	Wave Folder	Select the pattern on the built-in sequencer.
SEQ Ph Reset	SEQ Phase Reset	Wave Folder	Sets the mode for resetting the built-in sequencer.
SEQ Variation	SEQ Variation	Wave Folder	Changes the behavior of the built-in sequencer.
Shimmer Fdbk	Shimmer Feedback	Shimmer Reverb	Adjusts the feedback level of the pitch-shifted sound.

Display name	Parameter name	Effect types using the parameter	Description
Shimmer Gain	Shimmer Gain	Shimmer Reverb	Adjusts the level of the pitch-shifted sound.
Shimmer HPF	Shimmer HPF Frequency	Shimmer Reverb	Sets the Cutoff Frequency of the High Pass Filter for cutting the low frequency of the pitch-shifted sound.
Shimmer LPF	Shimmer LPF Frequency	Shimmer Reverb	Sets the Cutoff Frequency of the Low Pass Filter for cutting the high frequency of the pitch-shifted sound.
Side Bit	Side Bit	Bit Crusher	Reduces the bit precision for the side chain.
Side Chain EQ	Side Chain EQ Switch	Downward Compressor, Upward Compressor	Turns the EQ used for detecting the compressor level on or off.
Side Chain Lvl	Side Chain Input Level	VCM Compressor 376, Classic Compressor, Dyna Flanger, Dyna Phaser, Dyna Ring Mod, Dyna Filter, Multi Band Comp	Sets the level of the input to the control circuit for Side Chain.
Side Smpl Rate	Side Sample Rate	Bit Crusher	Reduces the Sample Rate for the Side
Size	Size	Shimmer Reverb	Sets the apparent size of the reverb space.
Smpl Rate Link	Sample Rate Link	Bit Crusher	Sets the level of the Side setting that follows the Mid value when M/S is on
Space Type	Space Type	Space Simulator	Selects the space simulation type.
Speaker Air	Speaker Air	U.S. Combo, Jazz Combo, U.S. High Gain, British Lead, British Combo, British Legend	Emphasizes the characteristics of the speaker cabinet.
Speaker Type	Speaker Type	Amp Simulator 1, Comp Distortion Delay	Selects the speaker simulation type.
		U.S. Combo, Jazz Combo, U.S. High Gain, British Lead, Small Stereo, British Combo, British Legend, Multi FX	Sets the speaker type.
Speed	Speed	VCM Flanger	Sets the frequency of the LFO wave which controls the cyclic change of the delay modulation.
		VCM Phaser Mono, VCM Phaser Stereo	Sets the frequency of the LFO wave which controls the cyclic change of the phase modulation.
		VCM Auto Wah	Sets the speed of the LFO.
		Vinyl Break	Sets the length of time for the sound to stop.
Speed Adjust	Speed Adjust	Vinyl Break	Finely adjusts the speed.
Speed Control	Speed Control	Rotary Speaker 1, Rotary Speaker 2	Switches the rotation speed (Slow/Fast)
		VCM Rotary Speaker Classic, VCM Rotary Speaker Overdrive, VCM Rotary Speaker Studio	Switches the rotation speed (Slow/Stop/Fast)
Spiral	Spiral Switch	Spiralizer P, Spiralizer F, Tempo Spiralizer P, Tempo Spiralizer F	Turns the LFO On or Off.
Spiral Speed	Spiral Speed	Spiralizer P, Spiralizer F, Tempo Spiralizer P, Tempo Spiralizer F	Sets the speed of the pitch change.
Spiral Sync	Spiral Sync	Spiralizer P, Spiralizer F, Tempo Spiralizer P, Tempo Spiralizer F	Sets the standard cycle for changing the pitch in steps.
Spread	Spread	Ensemble Detune, VCM Flanger, VCM Phaser Stereo, Control Phaser	Sets how the sound spreads.

Display name	Parameter name	Effect types using the parameter	Description
Stage	Stage	VCM Phaser Mono, VCM Phaser Stereo, Tempo Phaser, Dynamic Phaser, Control Phaser	Sets the number of steps for the phase shifter.
Step Mode	Spiral Step Mode	Spiralizer P, Spiralizer F, Tempo Spiralizer P, Tempo Spiralizer F	Sets the pitch to change continuously (smoothly) or in steps.
Step Transition	Spiral Step Transition Rate	Spiralizer P, Spiralizer F, Tempo Spiralizer P, Tempo Spiralizer F	Sets the transition time for the pitch to change in steps.
Sample Rate	Sample Rate	Bit Crusher	Lowers the Sample Rate
Sampling Freq	Sampling Frequency Control	Lo-Fi	Controls the sampling frequency.

T

Display name	Parameter name	Effect types using the parameter	Description
Texture	Texture	Parallel Compressor, Presence, VCM Mini Filter, VCM Mini Booster	Creates various changes to the texture of the effect.
Threshold	Threshold	Comp Distortion, Classic Compressor, Downward Compressor, Upward Compressor	Sets the input level for the effect to be applied.
Threshold Level	Dyna Threshold Level	Dynamic Flanger, Dynamic Phaser, Dynamic Ring Modulator, Dynamic Filter	Sets the minimum level at which the envelope follower starts.
Time Sweep	Time Sweep	Beat Repeat	Creates a gradual change in the time length with each repetition.
Tone	Tone	Rotary Speaker 2, VCM Rotary Speaker Classic, VCM Rotary Speaker Overdrive, VCM Rotary Speaker Studio	Sets the tone control.
Tone Shift	Tone Shift	British Lead	Switches the characteristic of the tone control.
Transition Rate	Delay Transition Rate	Control Delay	Sets the transition speed for changing the current Delay Time to the new value Delay Time
Treble	Treble	British Combo, British Lead, British Legend, Jazz Combo, U.S. High Gain	Adjusts the tone quality of the treble.
Type	Type	VCM Flanger, Control Flanger	Selects the flanger type.
		VCM Auto Wah, VCM Touch Wah, VCM Pedal Wah	Selects the Wah type.
		Early Reflection, Gated Reverb, Reverse Reverb	Selects the reflection type.
		US High Gain, British Lead	Selects the amplifier type.
		Analog Delay Retro, Analog Delay Modern	Sets the character of the delay.
		Parallel Compressor	Sets the compressor type.
		Mini Filter, Mini Boost	Sets the filter Type.

U

Display name	Parameter name	Effect types using the parameter	Description
Upper Range	Upper Range	VCM Auto Wah, VCM Touch Wah, VCM Pedal Wah	Sets the maximum value for the variable range of the Wah filter.
		Control Flanger	Sets the maximum value for the variable range of the Flanger Control
		Control Phaser	Sets the maximum value for the variable range of the Phase Control

V

Display name	Parameter name	Effect types using the parameter	Description
Vib Speed	Vib Speed	Jazz Combo	Sets the speed of the vibrato. Available when Chorus is set to Vib.
Vocoder Attack	Vocoder Attack	Vocoder	Sets the Attack value of the Vocoder output.
Vocoder Rls	Vocoder Release	Vocoder	Sets the Release value of the Vocoder output.
Volume	Volume	U.S. Combo, Jazz Combo	Sets the level of the preamp.
Vowel	Vowel	Talking Modulator	Selects a vowel type.

W

Display name	Parameter name	Effect types using the parameter	Description
Wah Pedal	Wah Pedal	Multi FX	Sets the position of the Wah pedal.
Wah Sw	Wah SW	Multi FX	Sets the Wah type.
Wall Vary	Wall Vary	Space Simulator	Sets the wall type of the simulated room. Higher values produce more diffuse reflections.
Width	Width	Space Simulator	Sets the width of the simulated room.
Width High	Width High	Stereophonic Optimizer	Adjusts the stereo balance of the High band
Width Low	Width Low	Stereophonic Optimizer	Adjusts the stereo balance of the Low band
Width Mid 1	Width Mid1	Stereophonic Optimizer	Adjusts the stereo balance of the Mid1 band
Width Mid 2	Width Mid2	Stereophonic Optimizer	Adjusts the stereo balance of the Mid2 band
Width Mid 3	Width Mid3	Stereophonic Optimizer	Adjusts the stereo balance of the Mid3 band
Word Length	Word Length	Lo-Fi	Sets the resolution of the sound, or how coarse the sound is.

Shortcuts and special operations

In addition to shortcut operations using the [SHIFT] button, etc., special operations can also be performed by pressing a button twice or holding it down.

Shortcuts

Operation	Function
[SHIFT] + Knob 1 to 4 (5 to 8)	Switches knob to high-precision mode (slower value changes) This is useful when you want to fine-tune a value
[SHIFT] + [EDIT/COPY]	Calls up the Copy/Exchange screen
[SHIFT] + KNOB POSITION [LEFT]	Registers the Assign 1–8 value assigned to the knob to the KNOB POSITION [LEFT] button
[SHIFT] + KNOB POSITION [MID]	Registers the Assign 1–8 value assigned to the knob to the KNOB POSITION [MID] button
[SHIFT] + KNOB POSITION [RIGHT]	Registers the Assign 1–8 value assigned to the knob to the KNOB POSITION [RIGHT] button
[SHIFT] + [PAGE JUMP]	Changes the parameters that can be switched with the [QUICK EDIT] button to match the parameters currently displayed on the screen
[SHIFT] + [PART SELECT]	Enables the PART buttons for turning the mute setting on or off
[SHIFT] + Part Group [1–8/9–16]	Enables the PART buttons and sliders to switch between Parts 9–16
[SHIFT] + [COMMON]	Selects Common for Elements, Operators, and Oscillators.
[SHIFT] + PART [1]–[8]	Selects one from Element 1–8, Operator 1–8, Oscillator 1–3, and Noise.
[SHIFT] + OCTAVE [-]	Sets the transpose value to -1 (reduce)
[SHIFT] + OCTAVE [+]	Sets the transpose value to +1 (increase)
[SHIFT] + OCTAVE [-] + OCTAVE [+]	Sets the transpose value to 0 (reset).
[SHIFT] + SCENE [1]–[8]	Registers the created Scene to one of the SCENE [1]–[8] buttons.
[SHIFT] + [DEC/NO]	Sets the selected parameter value to -10 (reduce) Returns to the previous page on the Live Set screen
[SHIFT] + [INC/YES]	Sets the selected parameter value to +10 (increase) Moves to the next page on the Live Set screen
[SHIFT] + [ARP]	Calls up the Arp Edit screen
[SHIFT] + [MSEQ]	Calls up the Motion Seq Edit screen
[SHIFT] + [CONTROL ASSIGN]	Calls up the Control View screen
[SHIFT] + [PERFORMANCE (HOME)]	Calls up the info screen (property screen) (Home screen only)
[SHIFT] + [LIVE SET]	Moves to the Live Set Register screen
[SHIFT] + [CATEGORY]	Opens the Part Category Search screen for the selected Part
[SHIFT] + [UTILITY]	Displays the parameter value.
[SHIFT] + [NAVIGATION]	Calls up the FX Overview screen
[SHIFT] + [QUICK SETUP]	Calls up the Effect Switch screen
[SHIFT] + [STORE]	Calls up the Load screen
[SHIFT] + [SPLIT]	Calls up the Homescreen with the Part-Note view selected
[SHIFT] + [SONG/PATTERN]	Calls up the Rhythm Pattern screen
[SHIFT] + [TEMPO/TAP]	Turns the panel lock function on or off (only on the Home screen or Live Set screen)
[SHIFT] + [A/D INPUT]	Calls up the Audio In Mixing screen
[SHIFT] + [PORTAMENTO]	Calls up the Pitch Edit screen
[SHIFT] + [ASSIGN 1]/[ASSIGN 2]	Calls up the Control Settings screen
[UTILITY] + [DAW REMOTE]	Selects the Calibration Touch Panel
OCTAVE [-] + OCTAVE [+]	Resets octave shift.

Other operations

Operation	Function
Quickly press the PART button twice	Switches between Internal and External When switched to External, the Part name is displayed in blue
Hold down the [CATEGORY] button	Resets Bank/Favorite (Bank/Favorite Select) to All

Message List

Message	Description	Required operation
** library will be overwritten.	The Library file with the same name has already been loaded when you tried to load a library. The existing data will be overwritten when the new data is loaded. The name of the Library file you are attempting to load is displayed in place of **.	
** Control Assign full.	Could not carry out the operation because there is no controller set available. The Part name you are attempting to add to the controller set is displayed in place of "***".	Delete the unnecessary controller set and redo the operation.
** will be deleted.	Data will be deleted as a result of this operation.	
** will be loaded to Pattern.	The .mid file will be loaded to the Pattern.	
** will be loaded to Song.	The .mid file will be loaded to the Song.	
** will be loaded.	The file will be loaded.	
** will be overwritten.	When saving, the Performance, file, folder, or Quick Setup with the same name already exists. The existing data will be overwritten by the data being saved. The name of the Performance, file, folder, or Quick Setup that you are attempting to save is displayed in place of "***".	
Activate the source controller to assign.	You can assign parameters to the controller you are about to operate.	Operate the controller that you wish to assign.
Advanced settings will be initialized.	Initializes the settings of the [UTILITY] → Settings → Advanced tab.	
All data and libraries will be initialized. Unsaved user data will be lost.	Restores the factory default settings.	It is recommended to save any necessary settings you wish to keep to a USB flash drive in advance.
All data is initialized upon power-on.	The instrument has been set to restore factory defaults when the instrument is turned on.	
All data will be overwritten by **	When loading is performed, all data will be overwritten. The name of the backup file you are attempting to load is displayed in place of "***".	
All Favorite Marks will be cleared.	All Favorite marks will be deleted.	
All settings will be initialized. User data is kept.	The settings for the instrument will be initialized. The User data will not be deleted.	
All sound will be stopped during optimization.	The internal memory will be restored.	
All user data will be initialized. Unsaved user data will be lost.	The User area in the User memory will be initialized.	It is recommended to save any necessary settings you wish to keep to a USB flash drive in advance.
Arpeggio bypass disabled.	Arpeggio Bypass is disabled.	
Arpeggio full.	Could not carry out the operation because the Arpeggio is full.	Delete unnecessary User Arpeggio data from the [UTILITY] → Contents → Data Utility screen.

Message	Description	Required operation
Assignable knob full.	Could not carry out the operation because all assignable knobs are used in the controller set.	Delete any unnecessary controller set that has an assignable knob set as a Source and redo the operation.
Audio file is not found.	The specified audio file cannot be found.	
Audio Rec stopped due to lack of memory space.	Audio recording stopped automatically because the USB flash drive is full.	Use a new USB flash drive or delete unnecessary files, and try this operation again.
Audition full.	Could not carry out the operation because the User Audition data is full.	Delete unnecessary User Audition data from the [UTILITY] → Contents → Data Utility screen.
Auto power off disabled.	The Auto Power Off function has been disabled.	
Bulk data protected.	Bulk data cannot be received because of the setting.	
Can't process.	Cannot process the requested operation.	
Can't register unstored performance.	Cannot register the Performance to the Live Set because the bank or program number being edited has not yet been set.	
Completed.	The specified load, save, format, or other Job has been completed.	
Connecting to USB device...	Connecting the USB flash drive to the instrument.	
Converting Pattern to Song.	The Pattern is being converted.	
CPU Fan Error	The built-in cooling fan has stopped.	This condition may cause the internal temperature to rise and the instrument may stop working. Immediately back up all necessary data, turn off the instrument and contact your Yamaha dealer.
Current user data will be overwritten by **.	User data already exists at the destination for the file to be loaded. If you proceed, the existing user data will be overwritten. The name of the User file you are attempting to load is displayed in place of “**.”	
Curve full	Could not carry out the operation because the User Curve data is full.	Delete unnecessary User Curve data from the [UTILITY] → Contents → Data Utility screen.
Data memory full.	(When loading a Library file) The content data in the library cannot be saved because the instrument memory is full.	
Device number is off.	The bulk data cannot be sent or received because the device number is off.	
Device number mismatch.	The bulk data cannot be sent or received because the device number does not match.	
Dividing the drum track makes new performance data. Performance full.	Cannot run because there is no room in the Performance created by using Divide Drum Track.	
Dividing the drum track makes new performance data. You can't undo this operation.	A new Performance will be created by using Divide Drum Track. This operation cannot be undone.	
File is not found.	There are no files for the selected type.	
File or folder already exists.	A file or folder with the same already exists.	

Message	Description	Required operation
File or folder path is too long.	Cannot open the specified file or folder because its path name is too long.	
Folder is not empty.	You are attempting to delete a folder that contains data.	
Folder is too deep.	The folder cannot be opened because the folder hierarchy is too deep.	
Illegal bulk data.	An error occurred while receiving bulk data or bulk requests.	
Illegal file name.	The file name is invalid.	
Illegal file.	The specified file cannot be handled or loaded into this instrument.	
Illegal parameters.	Incorrect parameters have been specified.	
Illegal sample data.	The specified sample data is not supported.	
Illegal smart morph data.	The specified Smart Morph data is not supported.	
Keybank full.	While loading, the total number of keybanks exceeds the maximum number.	
Keyboard control lock disabled.	Keyboard Lock is disabled.	
Knob value stored.	The Knob Value has been stored.	
Library full.	The total number of libraries exceeds the maximum number.	
Micro Tuning full.	Could not run because the User Micro Tuning data is full.	Delete unnecessary User Micro Tuning data from the [UTILITY] → Contents → Data Utility screen.
MIDI buffer full.	Could not be processed because an excessively large amount of MIDI data was received at once.	
MIDI checksum error.	The checksum of the received System Exclusive message is incorrect.	
No data.	There is no data in the selected track or specified range. Select the range again.	
No read/write authority to the file.	No read or write permissions for this file.	
Note ranges will be initialized.	The Note Range will be initialized.	
Now initializing all data...	The factory settings are being restored.	
Now initializing...	Some data is being initialized.	
Now loading...	The file is being loaded.	
Now receiving MIDI bulk data...	The instrument is receiving MIDI bulk data.	
Now saving...	The file is being saved.	
Now transmitting MIDI bulk data...	The instrument is sending MIDI bulk data.	
Panel unlocked.	The panel lock has been disabled.	
Part *** will be overwritten.	There is already a Part at the copy destination. If you continue the operation, the existing Part at the copy destination will be overwritten.	
Part full.	Could not open the Rhythm Pattern screen because there were no Parts available.	Delete the unnecessary Part(s) and redo the operation.
Pattern full.	Could not carry out the operation because the Pattern is full.	
Pattern will be converted to Song.	The Pattern will be converted to a Song.	

Message	Description	Required operation
Performance data in *** will be loaded.	The Performance Data in the file for a past model will be loaded.	
Performance full.	Could not carry out the operation because the Performance is full.	
Please connect USB device.	Connect a USB flash drive.	
Please keep power on.	Writing data in the flash ROM.	Do not turn off the instrument while this message is shown. If the instrument is turned off while this is displayed, User data may be lost or the system may be corrupted, preventing the system from starting properly the next time the instrument is turned on.
Please reboot to enable the new Audio I/O Mode.	Restart the instrument to enable the changes to the audio input and output settings.	
Please reboot to enable the new USB Driver Mode.	Restart the instrument to enable the changes to the USB driver mode settings.	
Please reboot to maintain internal memory.	Restart the instrument to repair the instrument memory.	
Please stop audio play/rec.	Stop audio recording or playback, and then try again.	
Please stop sequencer.	Stop the sequencer (Pattern or Song), and then try again.	
Please store the pattern to change the chain play mode.	Store the Pattern before changing the chain playback mode.	
Please wait...	Processing.	Please wait.
Press [SHIFT]+[TEMPO/TAP] to unlock panel.	Panel Lock has been enabled. Press [SHIFT] + [TEMPO/TAP] to unlock the panel.	
Quick Setup ** is loaded.	Quick Setup has been loaded.	
Recall latest edits.	Recalls the last edited Performance data and puts it in the edit buffer.	
Redo **.	Carries out the operation again (Redo) that had been undone. The name of the operation is displayed in place of "***."	
Sample is protected.	The sample is protected and cannot be changed.	
Sample is too long.	The sample size is too large and cannot be loaded.	
Turn on Memory Switch to memorize ** into this scene.	To register a function to a Scene, Memory (Memory Switch) for the function must be turned on in advance.	Open the screen from [PERFORMANCE (HOME)] → Scene and turn the switch on.
Undo **.	Cancels the immediately previous action (undo). The name of the operation is displayed in place of "***."	
Unsupported USB device.	This USB device is not supported by this instrument.	
USB connection terminated.	The USB flash drive was shut off due to abnormal current flow.	Disconnect the USB flash drive and then press any button on the top panel.
USB device is full.	The USB flash drive is full and files cannot be saved.	Use a new USB flash drive or delete unnecessary files, and try this operation again.

Message	Description	Required operation
USB device is write-protected.	The USB flash drive you are using is write-protected.	
USB device read/write error.	An error occurred during read/write to the USB flash drive.	
USB device will be formatted.	The USB flash drive will be formatted.	
User auditions will be overwritten with stored songs.	The existing User Audition will be overwritten by the currently stored Song.	
VCM Rotary is disabled except in Part 1.	The VCM Rotary can be used only with Part 1. It cannot be used on other Parts.	
Voice data in *** will be loaded.	The Voice Data in the file for a past model will be loaded.	
Waveform full.	The total number of waveforms exceeds the maximum number.	

When there's a problem

No sound? Wrong sound? When a problem like this occurs, make sure to check the troubleshooting section before assuming that the product is faulty.

Many problems can be solved by carrying out Initialize All Data, after backing up your data to a USB flash drive.

If the problem persists, consult your Yamaha dealer.

The touchscreen response is poor

- **Is the cursor pointing to the precise location you have touched on the touchscreen?**

If not, calibrate the touchscreen.

[UTILITY] + [DAW REMOTE] → Calibrate Touch Panel

[UTILITY] → Settings → System → Calibrate Touch Panel

No sound

- **Are Control sliders 1–8 at the lowest setting?**

Try moving Control sliders 1–8 to change their position.

- **Are any amplifiers, speakers, or headphones connected to the instrument?**

Since this instrument has no built-in speakers, it is necessary to connect amplifiers, speakers, or headphones to hear any sounds.

- **Is this instrument as well as any connected devices turned on?**

- **Have you made all the appropriate level settings—including the Master Volume on the instrument and the volume settings on the connected device?**

When a foot controller is connected to the FOOT CONTROLLER jack, try moving the foot controller.

- **Is Local Control set to Off?**

When Local Control is set to Off, no sound is produced when you play the keyboard.

[UTILITY] → Settings → MIDI I/O → Local Control

- **Is a blank Part selected?**

If so, assign a sound to the Part or select another Part.

- **Is the Mute switch for each Part turned on?**

When the Mute switch is turned on, no sound is produced when you play the keyboard.

[PERFORMANCE (HOME)] → Part selection → Mute

- **Is the Keyboard Control Switch of each Part turned off?**

[PERFORMANCE (HOME)] → Part selection → Keyboard Control Switch

- **Is the Arp Play Only of the selected Part turned on?**

When Arp Play Only is turned on, the corresponding Part produces sound only via Arpeggio playback.

[PERFORMANCE (HOME)] → Part selection → [EDIT/↶] → General / Pitch → Part Settings → Arp Play Only

[PERFORMANCE (HOME)] → Part selection → [EDIT/↶] → Arpeggio → Common → Arp Play Only

- **Are the MIDI volume or MIDI expression settings too low when using the external controller?**

- **Are the effect and filter settings appropriate?**

If you are using a filter, try changing the cutoff frequency. Some cutoff settings may filter out all of the sound.

[SHIFT]+[NAVIGATION]

[PERFORMANCE (HOME)] → Common selection → [EDIT/↶↷] → Effect

For Normal Parts (AWM2) and Drum Parts

[PERFORMANCE (HOME)] → Part selection → [EDIT/↶↷] → Select Element or Drum Key → Filter

[PERFORMANCE (HOME)] → Part selection → [EDIT/↶↷] → Effect

For Normal Parts (FM-X) and Normal Parts (AN-X)

[PERFORMANCE (HOME)] → Part selection → [EDIT/↶↷] → Filter / Amp

[PERFORMANCE (HOME)] → Part selection → [EDIT/↶↷] → Effect

- **Is Vocoder selected as the Insertion Effect Type of the Part?**

If so, set the parameters related to the A/D INPUT jacks to appropriate values, and then play the keyboard while speaking or singing into the microphone connected to this instrument. Check the A/D INPUT [GAIN] knob on the top panel is set to a value other than 0.

[PERFORMANCE (HOME)] → Part selection → [EDIT/↶↷] → Effect → Routing

[PERFORMANCE (HOME)] → Common selection → [EDIT/↶↷] → Audio In

- **Are the volume or level settings too low?**

[UTILITY] → Settings → Sound → Tone Generator Volume

[PERFORMANCE (HOME)] → Common selection → [EDIT/↶↷] → General/Pitch → Perf Settings → Volume

[PERFORMANCE (HOME)] → Part selection → [EDIT/↶↷] → General/Pitch → Part Settings → Volume

[PERFORMANCE (HOME)] → Part selection → [EDIT/↶↷] → Part Settings → Dry Level

For Normal Parts (AWM2) and Drum Parts

[PERFORMANCE (HOME)] → Part selection → [EDIT/↶↷] → Element or Drum Key selection → Amplitude → Level/Pan → Level

For Normal Parts (FM-X)

[PERFORMANCE (HOME)] → Part selection → [EDIT/↶↷] → Operator selection → Level → Level

For Normal part (AN-X)

[PERFORMANCE (HOME)] → Part selection → [EDIT/↶↷] → Oscillator selection → OSC/Tune → Out Level

- **Are the element switch, note limit, velocity limit, and velocity offset settings appropriate?**

For Normal Parts (AWM2) and Drum Parts

[PERFORMANCE (HOME)] → Part selection → [EDIT/↶↷] → General/Pitch → Part Settings

[PERFORMANCE (HOME)] → Part selection → [EDIT/↶↷] → Element or Drum Key selection → Osc/Tune

For Normal Parts (FM-X) and Normal Parts (AN-X)

[PERFORMANCE (HOME)] → Part selection → [EDIT/↶↷] → General/Pitch → Part Settings

- **Is the Mute switch for each Element or Operator of Part turned on?**

[PERFORMANCE (HOME)] → Part Common selection → Element, Operator, or Oscillator status on the Navigation bar

- **With a Normal Part (FM-X), is the Carrier Level set to “0”?**

[PERFORMANCE (HOME)] → Part selection → [EDIT/↶↷] → Operator selection → Level → Level

- **Is the output setting of each Part turned off?**

[PERFORMANCE (HOME)] → Part selection → [EDIT/↶↷] → General/Pitch → Part Settings → Part Output

- **Are the controller settings appropriate?**

When Destination is set to Volume or Cutoff, no sound is produced depending on the setting and controller status.

[PERFORMANCE (HOME)] → Part selection → [EDIT/↶↷] → Mod/Control → Control Assign

No sound from the A/D INPUT jacks

- **Is the connected microphone turned on?**

- **Is a dynamic microphone connected to the instrument?**

- **Is the cable between the microphone or audio equipment and this instrument properly connected?**

- **Is the A/D INPUT [GAIN] knob turned to the minimum?**

- **Is the [A/D INPUT] button turned on (lit)?**

- **Check if the cable connection to the A/D INPUT jacks matches the Mono/Stereo settings for the jack.**

[PERFORMANCE (HOME)] → Common selection → [EDIT/↶↷] → Audio In → Mixing → A/D In Input Mode

- **Are the Mic or Line settings appropriate?**

Set to Mic when a microphone or any device with a low output level is connected. Set to Line when an audio device, electronic instrument, or any device with a high input level is connected.

[UTILITY] → Settings → Audio I/O → A/D Input

- **Are the volume settings of the A/D Input Part too low?**

[PERFORMANCE (HOME)] → Common selection → [EDIT/↶↷] → Audio In → Mixing → A/D In Volume

- **Are the effect settings for the A/D Input Part appropriate?**

[PERFORMANCE (HOME)] → Common selection → [EDIT/↶↷] → Audio In → Routing

- **Is the output setting of the A/D Input Part appropriate?**

[PERFORMANCE (HOME)] → Common selection → [EDIT/↶↷] → Audio In → Mixing → A/D In Output Select

- **Check if the Vocoder effect is selected.**

If the insertion effect is set to use vocoder, the input sound from the A/D INPUT connector may not produce sound unless the keyboard is played.

[PERFORMANCE (HOME)] → Part selection → [EDIT/↶↷] → Effect → Routing

Playback continues without stopping

- When the [KEYBOARD HOLD] button is on, try turning it off.
- When the [ARP] button is on, try turning it off.
- For the Pattern/Song/Audio screen, press the [■] (Stop) button.
- When an effect sound (such as Delay) continues and does not stop, change the effect setting or select a different Performance.
- When the click sound continues, check the following setting.

If set to Always, the click sound will always sound. Set this parameter to something other than Always.

[UTILITY] → Tempo Settings → Click Mode

Distorted sound

- **Is the volume set too high?**

[UTILITY] → Settings → Sound → Tone Generator Volume

[UTILITY] → Settings → Audio I/O

[PERFORMANCE (HOME)] → Common selection → [EDIT/↶] → General/Pitch → Perf Settings → Volume

[PERFORMANCE (HOME)] → Part selection → [EDIT/↶] → General/Pitch → Part Settings → Volume

For Normal Parts (AWM2)

[PERFORMANCE (HOME)] → Part selection → [EDIT/↶] → Element selection → Amplitude → Level/Pan → Level

For Drum Parts

[PERFORMANCE (HOME)] → Part selection → [EDIT/↶] → Key selection → Level/Pan → Level

For Normal Parts (FM-X)

[PERFORMANCE (HOME)] → Part selection → [EDIT/↶] → Operator selection → Level → Level

For Normal part (AN-X)

[PERFORMANCE (HOME)] → Part selection → [EDIT/↶] → Oscillator selection → OSC/Tune → Out Level

The sound is cut off

- **Is the entire sound exceeding the maximum polyphony?**
 - AWM2 (preset waveforms): 128 sounds (both stereo and mono waveforms)
 - AWM2 (user or library waveforms): 128 sounds (both stereo and mono waveforms)
 - FM-X: 128
 - AN-X: 12

Only one note sounds at a time

- **Check if the tone generation mode is set to Mono.**

If you wish to play chords, set this parameter to Poly.

[PERFORMANCE (HOME)] → Part selection → [EDIT/↶↷] → General/Pitch → Part Settings → Mono/Poly

Wrong pitch

- **Is the Tune setting set too far from 0?**

[UTILITY] → Settings → Sound → Tone Generator Tune

- **Is the note shift or detuning for each part set to anything other than 0?**

[PERFORMANCE (HOME)] → Part selection → [EDIT/↶↷] → General/Pitch → Pitch → Note Shift

[PERFORMANCE (HOME)] → Part selection → [EDIT/↶↷] → General/Pitch → Pitch → Detune

- **If the part is out of pitch, is a special temperament selected in the micro tuning setting?**

[PERFORMANCE (HOME)] → Part selection → [EDIT/↶↷] → General/Pitch → Pitch → Micro Tuning Name

- **Have you set a special temperament in Global Tuning?**

[UTILITY] → Settings → Sound → Global Settings

- **When the Part produces a wrong pitch, is LFO Pitch Modulation Depth set too high?**

For Normal Parts (AWM2)

[PERFORMANCE (HOME)] → Part selection → [EDIT/↶↷] → Element selection → Element LFO → Pitch Mod

For Normal Parts (FM-X)

[PERFORMANCE (HOME)] → Part selection → [EDIT/↶↷] → Mod/Control → 2nd LFO → Pitch Modulation Depth

For Normal part (AN-X)

[PERFORMANCE (HOME)] → Part selection → [EDIT/↶↷] → General/Pitch → Pitch LFO → Pitch LFO Depth

- **If the part is out of pitch, are the coarse tuning and fine tuning misaligned?**

For Normal Parts (AWM2) and Drum Parts

[PERFORMANCE (HOME)] → Part selection → [EDIT/↶↷] → Element or Drum Key selection → Osc/Tune → Coarse

[PERFORMANCE (HOME)] → Part selection → [EDIT/↶↷] → Element or Drum Key selection → Osc/Tune → Fine

For Normal Parts (FM-X)

[PERFORMANCE (HOME)] → Part selection → [EDIT/↶↷] → Operator selection → Form/Freq → Coarse

[PERFORMANCE (HOME)] → Part selection → [EDIT/↶↷] → Operator selection → Form/Freq → Fine

- **If the part is out of pitch, is the controller destination set to pitch?**

[PERFORMANCE (HOME)] → Part selection → [EDIT/↶↷] → Mod/Control → Control Assign → Destination

- **For an AN-X Part, is Voltage Drift set to an excessively large value?**

[PERFORMANCE (HOME)] → Part selection → [EDIT/↶↷] → General/Pitch → AN-X Settings → Voltage Drift

No effect is applied

Check the effect settings using [SHIFT] + [NAVIGATION].

- **Is the Effect Switch off?**

[UTILITY] → Effect Switch

- **Are the variation send and reverb send values set at the lowest level?**

[PERFORMANCE (HOME)] → Part selection → [EDIT/↶] → Effect → Routing → Var Send

[PERFORMANCE (HOME)] → Part selection → [EDIT/↶] → Effect → Routing → Rev Send

- **Are the variation return and reverb return values set at the lowest level?**

[PERFORMANCE (HOME)] → Common selection → [EDIT/↶] → Effect → Routing → Var Return

[PERFORMANCE (HOME)] → Common selection → [EDIT/↶] → Effect → Routing → Rev Return

- **Is the Insertion Effect on all Elements or all Keys in the Part set to Thru?**

[PERFORMANCE (HOME)] → Part selection → [EDIT/↶] → Effect → Routing → Connect or Element 1–8

- **(For System Effects) Is the effect type selected for each effect set to No Effect?**

- **(For Insertion Effects) Is the effect type selected for each effect set to Thru?**

- **Is the Insertion Switch setting appropriate?**

[PERFORMANCE (HOME)] → Part selection → [EDIT/↶] → Effect → Ins A or Ins B

Cannot start the Arpeggio

- **Is the [ARP] button on?**

Check the number of Parts for which the Arpeggio switch is turned on. You can simultaneously play back Arpeggios for up to eight Parts.

- **Are the arpeggio note limits and velocity limits settings appropriate?**

[PERFORMANCE (HOME)] → Part selection → [EDIT/↶] → Arpeggio → Common

- **Is the Arpeggio Type set to Off?**

[PERFORMANCE (HOME)] → Part selection → [EDIT/↶] → Arpeggio → Individual → Name

- **Check the Arpeggio switch settings for each Part.**

When the Arpeggio switch is set to off, the Arpeggio will not be played back even when you turn on the [ARP] button on the Top panel.

[PERFORMANCE (HOME)] → Part selection → [EDIT/↶] → Arpeggio → Common, Individual, or Advanced → Arp Part

Cannot stop the Arpeggio

- **If you cannot stop Arpeggio playback by releasing your finger from the key, change the Arpeggio Hold switch to Off.**

[PERFORMANCE (HOME)] → Part selection → [EDIT/⟲] → Arpeggio → Common → Hold

- Turn off the [KEYBOARD HOLD] button on the Top panel.

Pattern or Song playback does not start by pressing the [▶] (Play) button

- Is there data in the selected pattern or song?

Cannot record pattern or song audio

- **Is there any memory space available for recording a Pattern or Song?**

Memory space on the instrument can hold up to 128 Patterns and 128 Songs. If you attempt to record more than 128 Songs or Patterns, you will get a Song full message, and no more recording is possible.

Data communication between the instrument and the connected computer is not working properly

- Is the Port setting on the computer appropriate?
- Have you selected the proper terminal (MIDI or USB) on the Utility screen?

[UTILITY] → Settings → MIDI I/O → MIDI IN/OUT

MIDI Bulk dump data transmission or reception is not working properly

- **Is Receive Bulk protected?**

Set MIDI Receive Bulk to On.

[UTILITY] → Settings → Advanced → MIDI Receive Bulk

- **To enable the reception of data recorded by using the Bulk dump function of this instrument, you must set the same device number for both transmission and reception.**

[UTILITY] → Settings → Advanced → MIDI Device Number

- **Is the same device number set to the connected MIDI device?**

[UTILITY] → Settings → Advanced → MIDI Device Number

Cannot save to the USB flash drive

- **Is the USB flash drive write-protected?**
- **Is there enough free space on the USB flash drive?**

Open the Content screen and set the device to a USB flash drive. Check to see if the free storage space shown in the upper right corner of the screen is 0.0 KB.

[UTILITY] → Contents → Save

- **Are you using a USB flash drive that has been confirmed to work with this instrument?**

Check the following URL for the list of USB devices that have been confirmed to work with this instrument.

<https://download.yamaha.com/>

In the display, there are some black points (unlit) or white points (always lit)

This is a characteristic of color LCDs, and is not a malfunction.

Restoring the factory default settings (Initialize All Data)

NOTICE

When the Initialize All Data function is carried out, all the Performances and songs stored in the User memory, as well as the settings for the entire instrument on the Utility screen, will be restored to the factory default settings. It is recommended to save any important data you wish to keep to a USB flash drive in advance.

1. Open the settings screen from [UTILITY] → Settings → System.

This calls up the settings screen for the entire instrument.

2. Tap Initialize All Data.

The confirmation screen appears.

To cancel the operation, tap the Cancel(NO) button on the screen or press the [DEC/NO] button on the top panel.

3. Tap the Initialize(YES) button on the screen or press the [INC/YES] button on the top panel.

The Initialize All Data operation is carried out.

