

STAGE PIANO

CP88**CP73****追加機能説明書****目次**

Version 2.00 新機能	3
Tempo Delay タイプの追加	4
ダンパーレゾナンスの調節機能追加	4
Output Gain の追加	5
Section SW Mode の追加	5
USB [TO DEVICE]の MIDI 対応	6
ライブセットのページ拡張	7
オートパワーオフ機能の時間変更	8
新ボイスの追加	9
新ライブセットサウンドの追加	11
Data List	14
Version 1.60 新機能	27
Mono/Poly、Portamentoの追加	28
Panの追加	29

Version 1.50 新機能.	30
Touch Sensitivityの追加.	31
新ボイスの追加	33
新ライブセットサウンドの追加	34
Version 1.40 新機能.	37
操作性の向上.	38
新ボイスの追加	39
新ライブセットサウンドの追加	40
Version 1.30 新機能.	43
マスター EQの設定をライブセットサウンドに保存する.	44
操作性の向上.	45
新ボイスの追加	46
新ライブセットサウンドの追加	47
Version 1.20 新機能.	50
Controllers以下の項目変更とパラメーターの追加.	51
LIVE SET [1] - [6]ボタンを使った設定項目の選択.	53
[EXIT] + [SETTINGS]で現在選択中の音色を初期化.	54
新ボイスの追加	55
新ライブセットサウンドの追加	56
Version 1.10 新機能.	58
全データファイルから1ライブセットサウンド単位でロードする.	59
MIDI Control Delayの追加	60
新ボイスの追加	61
新ライブセットサウンドの追加	62

Version 2.00 新機能

このたび、CP88/CP73ではファームウェアのバージョンアップにより、以下の機能が追加されました。
本書では、製品付属の取扱説明書に対して追加または変更となる点についてご説明します。

- DELAYエフェクトにTempo Delayタイプを追加しました。
- 「SETTINGS」に「Damper Resonance」項目を追加しました。
- 「MENU」に「Output Gain」項目を追加しました。
- 「MENU」に「Section SW Mode」項目を追加しました。
- USB [TO DEVICE]に MIDI機器を接続できるようになりました。
- ライブセットのページを拡張しました。
- オートパワーオフ機能で電源が切れるまでの時間を変更しました。
- 新規ボイスを追加しました。
- 新規ライブセットサウンドを追加しました。
- Data Listを更新しました。

Tempo Delay タイプの追加

ディレイエフェクトに Tempo Delay が追加されました。

Tempo Delay は[Analog/Digital]切り替えボタンで設定できます。

Tempo Delay が選択されているときは、[Analog/Digital]切り替えボタンと[TIME]ノブのランプが点滅します。

エフェクト	効果
Analog	アナログディレイ特有の温かいサウンドが特徴。[DEPTH]ノブで深さ、[FEEDBACK]ノブで繰り返し回数、[TIME]ノブでディレイタイムを調節します。ディレイタイムは最大 800 ms です。
Digital	クリーンなデジタルディレイ。[DEPTH]ノブで深さ、[FEEDBACK]ノブで繰り返し回数、[TIME]ノブでディレイタイムを調節します。ディレイタイムは最大 1,486 ms です。
Tempo	曲のテンポに合わせるディレイです。テンポと音符の長さ(Tempo Delay Time)を指定して、その長さでディレイがかかります。初期設定は 1/4 (4分音符)です。[DEPTH]ノブで深さ、[FEEDBACK]ノブでフィードバックレベル、[TIME]ノブでテンポを調整します。テンポは、[EXIT]ボタンを押しながら [Analog/Digital]切り替えボタンを数回タップすることでも設定できます。 NOTE 音符の長さは、[SETTINGS] → 「Sound」 → 「Tempo Delay Time」、または[EXIT]ボタンを押しながら[TIME]ノブで設定できます。

ダンパーレゾナンスの調節機能追加

[SETTINGS]ボタン → 「Sound」 → 「Piano」 → 「Damper Resonance」

ダンパーレゾナンスとは、ピアノのダンパーペダルを踏んだときの開放弦による音の広がり再現するエフェクトです。ドライ/ウェットのバランス(Dry/Wet Balance)と弦の開放度(Damper Control)を調節します。

初期設定

- Dry/Wet Balance: D39>W
- Damper Control: 0

Output Gain の追加

Menu から Output Gain (-24dB~0dB~+24dB)が調節できるようになりました。

新旧ツリー図

・V1.60

Menu

- └ General
 - | └ Master Tune
 - | └ MIDI Settings
 - | └ Keyboard/Pedal
 - | └ Local Control
 - | └ USB Audio Volume
 - | └ Auto Power Off
- └ Control Panel
- └ Job
- └ File
- └ Version Info

・V2.00

Menu

- └ General
 - | └ Master Tune
 - | └ MIDI Settings
 - | └ Keyboard/Pedal
 - | └ Local Control
 - | └ I/O Volume
 - | └ USB Audio
 - | └ Output Gain
 - | └ Auto Power Off
- └ Control Panel
- └ Job
- └ File
- └ Version Info

Section SW Mode の追加

[MENU]ボタン → 「Control Panel」 → 「Advanced Settings」 → 「Section SW Mode」

ボイスセクション [ON/OFF] スイッチに新しいモードを追加しました。

以下の 2 タイプから設定できます。

機能名		内容
Section SW Mode	Realtime	ボイスセクション [ON/OFF] スイッチを無効 (オフ) にすると、各ボイスセクションで発音中の音が止まります。
	Next-Key	押鍵中のノートはボイスセクション [ON/OFF] スイッチを無効 (オフ) にしても音は止まりません。その押鍵された鍵盤を離鍵すると音は止まり、次の押鍵から発音されません。
初期設定: Realtime		

USB [TO DEVICE]の MIDI 対応

USB [TO DEVICE]端子に接続された MIDI 機器からの MIDI 入力に対応しました。

USB [TO DEVICE]端子に USB MIDI キーボードなどを接続すると、接続した USB MIDI キーボードの機能に応じて、本機に装備されている鍵盤と同じように扱えます。

ご注意

- USB [TO DEVICE]端子の定格は、最大 5V/500mA です。定格を超える USB 機器は故障の原因になるため、接続しないでください。
- USB ケーブルは AB タイプで、3 メートル未満のものをご使用ください。

使用できる MIDI 機器

- USB クラスコンプライアント対応の MIDI 機器

USB MIDI キーボードなど

- 動作確認済みのヤマハ MIDI 機器

CP1、CP4 STAGE、CP40 STAGE、CP88、CP73、MODX、MODX+、MONTAGE、MOTIF XF、MOXF、MX、reface、YC、MONTAGE M、CK

MIDI 通信時の特別な動作

本機に装備されている鍵盤に近い扱いとするため、USB [TO DEVICE]端子で接続した機器との MIDI 通信では特別な動作をします。

- MIDI 通信は一方方向だけ(外部 MIDI 機器から送信し、本機で受信する)
- MIDI Port, MIDI Channel の設定に関係なく、すべての MIDI 情報が受信される

ライブセットのページ拡張

ライブセットページが 20 ページから 40 ページに拡張されました。

トップ画面で[EXIT]ボタンを押しながら PAGE [-]ボタンや PAGE [+]ボタンを使うことで、10 ページ単位で切り替えできるようになりました。

NOTE

バージョン 2.0 で作成したライブセットを、それ以前のバージョンで読み込んだとき、20 ページまでしか読み込みできません。

オートパワーオフ機能の時間変更

オートパワーオフ機能を有効にした場合に、自動的に電源が切れるまでの時間を約30分から約15分へと変更しました。
また、オートパワーオフの設定画面を開くと、「Energy consumption might increase depending on the setting.」と表示されるようにしました。

[MENU]ボタン → 「General」 → 「Auto Power Off」 → 「Enable」(有効)

新ボイスの追加

2個の新規ボイス()を追加しました。

Voice List

Section	Category	No.	Voice	CC No.	CC #	
PIANO	Grand Piano	1	CFX	1	12	
		2	Imperial	2	12	
		3	S700	3	12	
		4	Digi Piano	4	12	
		5	C7	58	12	
		6	CF3	92	12	
		7	Nashville C3	95	12	
		8	Live CF3	96	12	
		9	Hamburg Grand	107	12	
		10	CFX2	1	44	
		11	Imperial+	2	44	
	Upright Piano	1	U1	5	12	
		2	SU7	6	12	
		3	Felt Piano	108	12	
	CP	1	CP80 1	7	12	
		2	CP80 2	8	12	
	Layered Piano	1	Piano Strings	9	12	
		2	Piano Synth	10	12	
	E.PIANO	Rd	1	78Rd	11	12
2			75Rd Funky	12	12	
3			73Rd	13	12	
4			67Rd Dark	59	12	
5			67Rd Bright	60	12	
6			73Rd Studio	93	12	
7			74Rd Stage	94	12	
Wr		1	Wr Warm	14	12	
		2	Wr Bright	15	12	
		3	Wr Wide	61	12	
Clv		1	Clavi B	16	12	
		2	Clavi S	17	12	
		3	Harpichord	18	12	
DX		1	DX Legend	19	12	
		2	DX Woody	20	12	
		3	DX FTine	21	12	
		4	DX 7 II	22	12	
		5	DX Mellow	23	12	
		6	DX Crisp	24	12	
SUB		Pad/Strings	1	Mellow Pad	25	12
			2	Spectrum	26	12
			3	Back Pad	27	12
			4	Air Choir	28	12
			5	Natural Str	29	12
	6		Warm Strings	30	12	
	7		OB Strings	31	12	
	8		Section Str	32	12	
	9		Fat Saw Pad	62	12	
	10		Noble Pad	63	12	
	11		Pop Pad	64	12	
	12		Analog Pad	65	12	
	13		Itopia	66	12	
	14		Marcato Str	67	12	
	15		Slow Str	68	12	
	16		Tape Str	69	12	
	17		Oct Syn Str	70	12	
	18		Angel Pad	97	12	
	19		Mystic Pad	98	12	
	20		JP Strings	99	12	
	21		Pop Syn Str	100	12	
	22		Fast Strings	101	12	
	23		Pizzicato	102	12	
	24		Dark Light	109	12	

Section	Category	No.	Voice	CC No.	CC #
SUB	Pad/Strings	25	Digi Pad	110	12
		26	Lite Strings	111	12
		27	Unison Str	112	12
		28	Violin	113	12
		29	Cello	114	12
	Organ	1	Bright Bars	33	12
		2	Click Organ	34	12
		3	Draw Organ 1	35	12
		4	All Bars Out	36	12
		5	Draw Organ 2	37	12
		6	60s Combo	38	12
		7	Compact	39	12
		8	Panther	40	12
		9	Pipe Organ 1	41	12
		10	Pipe Organ 2	42	12
		11	Accordion	103	12
		12	Musette	115	12
	Chromatic Perc.	1	Glocken	43	12
		2	Vibraphone	44	12
		3	Xylophone	45	12
		4	Marimba	46	12
		5	Brightness	47	12
		6	Nice Bell	48	12
		7	Stack Bell	49	12
		8	Jazz Vibes	71	12
		9	Marimba 2	72	12
		10	Kalimba	73	12
		11	Heaven Bell	74	12
	Others	1	Syn Lead 1	50	12
		2	Syn Lead 2	51	12
		3	Syn Bass	52	12
		4	E.Bass	53	12
		5	A.Bass	54	12
6		Steel Gt	55	12	
7		Clean Gt	56	12	
8		Syn Brass	57	12	
9		Sine Lead	75	12	
10		Sync Saw	76	12	
11		Dirty Hook	77	12	
12		Classic Mini	78	12	
13		Funky Mini	79	12	
14		Nu Mini	80	12	
15		80s Pop Bass	81	12	
16		Sub Bass	82	12	
17		Unison Bass	83	12	
18		Finger Bass	84	12	
19		Brass	85	12	
20		Syn Brass 2	86	12	
21		OB Brass 1	87	12	
22		OB Brass 2	88	12	
23		Jazz Flute	89	12	
24		Tape Flute	90	12	
25		Harmonica	91	12	
26		Classic Gt	104	12	
27		Steel Gt 2	105	12	
28		Sf. Brass	106	12	
29		12Strings Gt	116	12	
30		Clean Gt 2	117	12	
31		Syn Brass 3	118	12	
32		Horn	119	12	
33		Sax Section	120	12	

Section	Category	No.	Voice	CC No.	CC #
		34	Soprano Sax	121	12
		35	Alto Sax	122	12
		36	Tenor Sax	123	12
		37	Baritone Sax	124	12
		38	Soft Square	125	12
		39	Calliope Lead	126	12
		40	1o1 Bass	127	12

新ライブセットサウンドの追加

新規ボイスを使った新規ライブセットサウンド()が追加されました。

Live Set Sound List

Page	No	Name	Split Point	Section	Voice Name	MSB	LSB	PC	Page	No	Name	Split Point	Section	Voice Name	MSB	LSB	PC
1	1	Natural CFX	G2	Piano	CFX	63	0	1	4	1	Compressed CFX	G2	Piano	CFX	63	3	1
				E.Piano	-								E.Piano	-			
				Sub	-								Sub	-			
1	2	NaturalImperial	G2	Piano	Imperial	63	0	2	4	2	Kinda Squashed	G2	Piano	Imperial	63	3	2
				E.Piano	-								E.Piano	-			
				Sub	-								Sub	-			
1	3	Jazz S700	G2	Piano	S700	63	0	3	4	3	Layered CFX	G2	Piano	CFX	63	3	3
				E.Piano	-								E.Piano	75Rd Funky			
				Sub	-								Sub	Mellow Pad			
1	4	Rock Upright	G2	Piano	U1	63	0	4	4	4	Chorus CFX	G2	Piano	CFX	63	3	4
				E.Piano	-								E.Piano	-			
				Sub	-								Sub	-			
1	5	Simple 78	G2	Piano	-	63	0	5	4	5	Upright	G2	Piano	U1	63	3	5
				E.Piano	78Rd								E.Piano	-			
				Sub	-								Sub	-			
1	6	Funky Tines	G2	Piano	-	63	0	6	4	6	A Tacky Piano	G2	Piano	SU7	63	3	6
				E.Piano	75Rd Funky								E.Piano	75Rd Funky			
				Sub	-								Sub	Brightness			
1	7	Tremolo Wr	G2	Piano	-	63	0	7	4	7	HonkyTonk Piano	G2	Piano	U1	63	3	7
				E.Piano	Wr Warm								E.Piano	-			
				Sub	-								Sub	-			
1	8	Clavi B Amped	G2	Piano	-	63	0	8	4	8	Old Record	G2	Piano	U1	63	3	8
				E.Piano	Clavi B								E.Piano	-			
				Sub	-								Sub	-			
2	1	CFX+DX Legend	G2	Piano	CFX	63	1	1	5	1	Case 73	G2	Piano	-	63	4	1
				E.Piano	DX Legend								E.Piano	73Rd			
				Sub	-								Sub	-			
2	2	A.Bass/78Rd	G2	Piano	U1	63	1	2	5	2	Chimin' Tines	G2	Piano	Digi Piano	63	4	2
				E.Piano	78Rd								E.Piano	78Rd			
				Sub	A.Bass								Sub	Glocken			
2	3	80s El Grand	G2	Piano	CP80 1	63	1	3	5	3	Slow Phase	G2	Piano	-	63	4	3
				E.Piano	-								E.Piano	73Rd			
				Sub	-								Sub	-			
2	4	Brite Pop 8ve	G2	Piano	Digi Piano	63	1	4	5	4	73 Tines OD	G2	Piano	-	63	4	4
				E.Piano	DX Legend								E.Piano	73Rd			
				Sub	OB Strings								Sub	-			
2	5	E.Bass/78Rd	G2	Piano	-	63	1	5	5	5	Fast Phaser	G2	Piano	-	63	4	5
				E.Piano	78Rd								E.Piano	75Rd Funky			
				Sub	E.Bass								Sub	-			
2	6	Driven Wr+Pad	G2	Piano	-	63	1	6	5	6	Ampy Funk	G2	Piano	-	63	4	6
				E.Piano	Wr Warm								E.Piano	75Rd Funky			
				Sub	Warm Strings								Sub	-			
2	7	Imperial + Str	G2	Piano	Imperial	63	1	7	5	7	Wet Phase	G2	Piano	-	63	4	7
				E.Piano	-								E.Piano	78Rd			
				Sub	Section Str								Sub	-			
2	8	Ghostly U1	G2	Piano	U1	63	1	8	5	8	78 & Pad	G2	Piano	-	63	4	8
				E.Piano	Wr Warm								E.Piano	78Rd			
				Sub	-								Sub	Mellow Pad			
3	1	Rock Grand	G2	Piano	CFX	63	2	1	6	1	Wr Bright	G2	Piano	-	63	5	1
				E.Piano	-								E.Piano	Wr Bright			
				Sub	-								Sub	-			
3	2	S700 + Pad	G2	Piano	S700	63	2	2	6	2	Wr Comp	G2	Piano	-	63	5	2
				E.Piano	-								E.Piano	Wr Warm			
				Sub	OB Strings								Sub	-			
3	3	MonoCmp CFX	G2	Piano	CFX	63	2	3	6	3	Clavi B	G2	Piano	-	63	5	3
				E.Piano	-								E.Piano	Clavi B			
				Sub	-								Sub	-			
3	4	Lo Fi Grand	G2	Piano	CFX	63	2	4	6	4	Driven S	G2	Piano	-	63	5	4
				E.Piano	-								E.Piano	Clavi S			
				Sub	-								Sub	-			
3	5	Piano Grind Pad	G2	Piano	Piano Synth	63	2	5	6	5	Clavi Wah Dist	G2	Piano	-	63	5	5
				E.Piano	73Rd								E.Piano	Clavi B			
				Sub	Mellow Pad								Sub	-			
3	6	Lush Love	G2	Piano	Imperial	63	2	6	6	6	Squeeze B	G2	Piano	-	63	5	6
				E.Piano	78Rd								E.Piano	Clavi B			
				Sub	Brightness								Sub	-			
3	7	Big S700	G2	Piano	S700	63	2	7	6	7	Long Chorus S	G2	Piano	-	63	5	7
				E.Piano	73Rd								E.Piano	Clavi S			
				Sub	OB Strings								Sub	-			
3	8	Piano Scape	G2	Piano	Imperial	63	2	8	6	8	Rock Wr w/Ba	G2	Piano	Digi Piano	63	5	8
				E.Piano	DX Legend								E.Piano	Wr Bright			
				Sub	Mellow Pad								Sub	E.Bass			

Page	No	Name	Split Point	Section	Voice Name	MSB	LSB	PC
7	1	CP80 Comp	G2	Piano	CP80 1	63	6	1
				E.Piano	-			
				Sub	-			
7	2	Natural CP80	G2	Piano	CP80 2	63	6	2
				E.Piano	-			
				Sub	-			
7	3	Chorus Legend	G2	Piano	-	63	6	3
				E.Piano	DX Legend			
				Sub	-			
7	4	Chorus FTine	G2	Piano	-	63	6	4
				E.Piano	DX FTine			
				Sub	Mellow Pad			
7	5	Chorus 7II	G2	Piano	-	63	6	5
				E.Piano	DX 7 II			
				Sub	-			
7	6	Legend + Pad	G2	Piano	-	63	6	6
				E.Piano	DX Legend			
				Sub	OB Strings			
7	7	SynBass/DXEP	G2	Piano	-	63	6	7
				E.Piano	DX Mellow			
				Sub	Syn Bass			
7	8	Digi DX Pads	G2	Piano	Digi Piano	63	6	8
				E.Piano	DX Legend			
				Sub	Mellow Pad			
8	1	Bright Bars	G2	Piano	-	63	7	1
				E.Piano	-			
				Sub	Bright Bars			
8	2	All Bars Out	G2	Piano	-	63	7	2
				E.Piano	-			
				Sub	All Bars Out			
8	3	PipeOrgan1	G2	Piano	-	63	7	3
				E.Piano	-			
				Sub	Pipe Organ 1			
8	4	PipeOrgan2	G2	Piano	-	63	7	4
				E.Piano	-			
				Sub	Pipe Organ 2			
8	5	The Red Combo	G2	Piano	-	63	7	5
				E.Piano	-			
				Sub	60s Combo			
8	6	Italian Combo	G2	Piano	-	63	7	6
				E.Piano	-			
				Sub	Compact			
8	7	Aggro Syn Pad	G2	Piano	-	63	7	7
				E.Piano	78Rd			
				Sub	Panther			
8	8	RdBa/60sCombo	G2	Piano	-	63	7	8
				E.Piano	78Rd			
				Sub	60s Combo			
9	1	Strings1	G2	Piano	-	63	8	1
				E.Piano	-			
				Sub	Natural Str			
9	2	Strings2	G2	Piano	-	63	8	2
				E.Piano	-			
				Sub	Section Str			
9	3	Synth Pad1	G2	Piano	-	63	8	3
				E.Piano	-			
				Sub	Mellow Pad			
9	4	Synth Pad2	G2	Piano	-	63	8	4
				E.Piano	-			
				Sub	Warm Strings			
9	5	Vibraphone	G2	Piano	-	63	8	5
				E.Piano	-			
				Sub	Vibraphone			
9	6	Nice Bell	G2	Piano	-	63	8	6
				E.Piano	-			
				Sub	Nice Bell			
9	7	Syn Brass	G2	Piano	-	63	8	7
				E.Piano	-			
				Sub	Syn Brass			
9	8	Syn Lead1	G2	Piano	-	63	8	8
				E.Piano	78Rd			
				Sub	Syn Lead 1			

Page	No	Name	Split Point	Section	Voice Name	MSB	LSB	PC
10	1	Harpsichord	G2	Piano	-	63	9	1
				E.Piano	Harpsichord			
				Sub	-			
10	2	Electric Harpsi	G2	Piano	-	63	9	2
				E.Piano	Harpsichord			
				Sub	-			
10	3	Pipes Rd PBMW	G2	Piano	Digi Piano	63	9	3
				E.Piano	78Rd			
				Sub	Pipe Organ 2			
10	4	Funky w/RdBass	G2	Piano	CP80 1	63	9	4
				E.Piano	78Rd			
				Sub	Marimba			
10	5	Rough Lead	G2	Piano	CP80 2	63	9	5
				E.Piano	78Rd			
				Sub	Back Pad			
10	6	Clavi Syn Wah	G2	Piano	-	63	9	6
				E.Piano	Clavi B			
				Sub	Syn Lead 1			
10	7	Chimin' Crs	G2	Piano	Digi Piano	63	9	7
				E.Piano	75Rd Funky			
				Sub	Glocken			
10	8	Brite Pop	G2	Piano	Digi Piano	63	9	8
				E.Piano	DX Legend			
				Sub	OB Strings			
11	1	Back to 60s SP	G2	Piano	-	63	10	1
				E.Piano	67Rd Dark			
				Sub	-			
11	2	80s Piano JG	G2	Piano	C7	63	10	2
				E.Piano	78Rd			
				Sub	-			
11	3	NaturalWrWideJG	G2	Piano	-	63	10	3
				E.Piano	Wr Wide			
				Sub	-			
11	4	Chorused67Rd SP	G2	Piano	-	63	10	4
				E.Piano	67Rd Bright			
				Sub	-			
11	5	R&B Ballad NS	G2	Piano	-	63	10	5
				E.Piano	67Rd Dark			
				Sub	-			
11	6	Squashed C7 NS	G2	Piano	C7	63	10	6
				E.Piano	-			
				Sub	-			
11	7	WrWideChorus SP	G2	Piano	-	63	10	7
				E.Piano	Wr Wide			
				Sub	-			
11	8	Driven 67Rd JG	G2	Piano	-	63	10	8
				E.Piano	67Rd Bright			
				Sub	-			
12	1	CFX + Slow Str	G2	Piano	CFX	63	11	1
				E.Piano	-			
				Sub	Slow Str			
12	2	C7 + Noble Pad	G2	Piano	C7	63	11	2
				E.Piano	-			
				Sub	Noble Pad			
12	3	78Rd+AnalogPad	G2	Piano	-	63	11	3
				E.Piano	78Rd			
				Sub	Analog Pad			
12	4	78Rd+OBBrass MW	G2	Piano	-	63	11	4
				E.Piano	78Rd			
				Sub	OB Brass 1			
12	5	Sync Saw/DX EP	C3	Piano	-	63	11	5
				E.Piano	DX Legend			
				Sub	Sync Saw			
12	6	Fat Saw Pad MW	G2	Piano	-	63	11	6
				E.Piano	-			
				Sub	Fat Saw Pad			
12	7	OB Brass	G2	Piano	-	63	11	7
				E.Piano	-			
				Sub	OB Brass 2			
12	8	Marcato Str	G2	Piano	-	63	11	8
				E.Piano	-			
				Sub	Marcato Str			

Page	No	Name	Split Point	Section	Voice Name	MSB	LSB	PC
13	1	73Rd Studio	G2	Piano	-	63	12	1
				E.Piano	73Rd Studio			
				Sub	-			
13	2	73Rd Chorus	G2	Piano	-	63	12	2
				E.Piano	73Rd Studio			
				Sub	-			
13	3	73Rd+AnalogPad	G2	Piano	-	63	12	3
				E.Piano	73Rd Studio			
				Sub	Analog Pad			
13	4	73Rd+AP	G2	Piano	C7	63	12	4
				E.Piano	73Rd Studio			
				Sub	-			
13	5	74Rd Stage	G2	Piano	-	63	12	5
				E.Piano	74Rd Stage			
				Sub	-			
13	6	Overdriven 74Rd	G2	Piano	-	63	12	6
				E.Piano	74Rd Stage			
				Sub	-			
13	7	CF3	G2	Piano	CF3	63	12	7
				E.Piano	-			
				Sub	-			
13	8	CF3+AnalogPad	G2	Piano	CF3	63	12	8
				E.Piano	-			
				Sub	Analog Pad			
14	1	Nashville C3	G2	Piano	Nashville C3	63	13	1
				E.Piano	-			
				Sub	-			
14	2	NVille C3 Comp	G2	Piano	Nashville C3	63	13	2
				E.Piano	-			
				Sub	-			
14	3	Fat Jazz Ballad	G2	Piano	Nashville C3	63	13	3
				E.Piano	78Rd			
				Sub	Vibraphone			
14	4	Fundamental Pad	G2	Piano	Nashville C3	63	13	4
				E.Piano	73Rd			
				Sub	Analog Pad			
14	5	Live CF3	G2	Piano	Live CF3	63	13	5
				E.Piano	-			
				Sub	-			
14	6	WestCoast CF3	G2	Piano	Live CF3	63	13	6
				E.Piano	78Rd			
				Sub	Analog Pad			
14	7	Gospel CF3	G2	Piano	Live CF3	63	13	7
				E.Piano	-			
				Sub	-			
14	8	Piano Pad CF3	G2	Piano	Live CF3	63	13	8
				E.Piano	-			
				Sub	Analog Pad			

Page	No	Name	Split Point	Section	Voice Name	MSB	LSB	PC
15	1	Hamburg Grand	G2	Piano	Hamburg Grand	63	14	1
				E.Piano	-			
				Sub	-			
15	2	Ambient Hamburg	G2	Piano	Hamburg Grand	63	14	2
				E.Piano	-			
				Sub	-			
15	3	Soft Ballad H-G	G2	Piano	Hamburg Grand	63	14	3
				E.Piano	78Rd			
				Sub	-			
15	4	Romance Layer	G2	Piano	Hamburg Grand	63	14	4
				E.Piano	-			
				Sub	Slow Str			
15	5	Felt Piano	G2	Piano	Felt Piano	63	14	5
				E.Piano	-			
				Sub	-			
15	6	Night Moods	G2	Piano	Felt Piano	63	14	6
				E.Piano	67Rd Dark			
				Sub	Analog Pad			
15	7	Big MusicBox	G2	Piano	Felt Piano	63	14	7
				E.Piano	DX FTine			
				Sub	E. Bass			
15	8	All Mellow	G2	Piano	Felt Piano	63	14	8
				E.Piano	Wr Wide			
				Sub	Soft Square			
16	1	CFX2	G2	Piano	CFX2	63	15	1
				E.Piano	-			
				Sub	-			
16	2	CFX2/78Rd	G2	Piano	CFX2	63	15	2
				E.Piano	78Rd			
				Sub	-			
16	3	Quiet CFX2	G2	Piano	CFX2	63	15	3
				E.Piano	73Rd			
				Sub	Analog Pad			
16	4	Blockbuster	G2	Piano	CFX2	63	15	4
				E.Piano	DX Legend			
				Sub	Slow Str			
16	5	Imperial+	G2	Piano	Imperial+	63	15	5
				E.Piano	-			
				Sub	-			
16	6	Studio Layer	G2	Piano	Imperial+	63	15	6
				E.Piano	Wr Wide			
				Sub	-			
16	7	Warm Layer	G2	Piano	Imperial+	63	15	7
				E.Piano	DX 7 II			
				Sub	Analog Pad			
16	8	Distant Ring	G2	Piano	Imperial+	63	15	8
				E.Piano	67Rd Bright			
				Sub	Sub Bass			

Data List

Data List を更新しました。

DATA LIST

Control Change Number List

P:=Piano, E:=Electric Piano, S:=Sub
 括弧付きで表示されるパラメーターは、本体の音源には効果しません。
 *：フットスイッチのみ有効です。フットコントローラーには反応しません。
 *コントローラー値/パラメーター値対応表 (16ページ)

	CC No. (ディスプレイ表示)	コントローラー	対応表*
Piano	12 または 44 P: Select	18 ボイスカテゴリーセクター	M
		19 ボイスセレクトスイッチ	M
	13 P: Volume	23 [VOLUME]ノブ	A
	14 P: Tone	24 [TONE]ノブ	A
	15 P: Damper Reso	25 DAMPER RESONANCE [ON/OFF]ボタン	B
	16 P: Effect SW	26 インサージョンエフェクト[ON/OFF]ボタン	B
	17 P: Effect Depth	28 [DEPTH]ノブ	A
	77 P: Delay Depth	44 [DEPTH]ノブ	A
	81 P: Reverb Depth	46 [DEPTH]ノブ	A
	102 P: SW	17 ボイスセクション[ON/OFF]スイッチ	B
	103 P: Split	21 SPLIT [L R]ボタン	E
	104 P: Octave	22 OCTAVE [-2 -1]/[+1 +2]ボタン	F
	105 P: Effect Type	27 インサージョンエフェクト 切り替えボタン	G
E.Piano	18 E: Select	18 ボイスカテゴリーセクター	N
		19 ボイスセレクトスイッチ	N
	19 E: Volume	23 [VOLUME]ノブ	A
	20 E: Tone	24 [TONE]ノブ	A
	21 E: Drive SW	26 インサージョンエフェクト[ON/OFF]ボタン	B
	22 E: Drive Depth	28 [DRIVE]ノブ	A
	23 E: Effect 1 SW	26 インサージョンエフェクト[ON/OFF]ボタン	B
	24 E: Effect 1 Depth	31 [DEPTH]ノブ	A
	25 E: Effect 1 Rate	32 [RATE]ノブ	A
	26 E: Effect 2 SW	26 インサージョンエフェクト[ON/OFF]ボタン	B
	27 E: Effect 2 Depth	34 [DEPTH]ノブ	A
	28 E: Effect 2 Speed	35 [SPEED]ノブ	A
	78 E: Delay Depth	44 [DEPTH]ノブ	A
	82 E: Reverb Depth	46 [DEPTH]ノブ	A
	106 E: SW	17 ボイスセクション[ON/OFF]スイッチ	B
	107 E: Split	21 SPLIT [L R]ボタン	E
	108 E: Octave	22 OCTAVE [-2 -1]/[+1 +2]ボタン	F
	109 E: Effect 1 Type	30 インサージョンエフェクト 切り替えボタン	H
	110 E: Effect 2 Type	33 インサージョンエフェクト 切り替えボタン	I
	Sub	29 S: Select	18 ボイスカテゴリーセクター
19 ボイスセレクトスイッチ			O
30 S: Volume		23 [VOLUME]ノブ	A
31 S: Tone		24 [TONE]ノブ	A
68 S: Effect SW		26 インサージョンエフェクト[ON/OFF]ボタン	B
72 S: Release		37 [RELEASE]ノブ	A
73 S: Attack		35 [ATTACK]ノブ	A
75 S: Effect Depth		39 [DEPTH]ノブ	A
76 S: Effect Speed		40 [SPEED]ノブ	A
79 S: Delay Depth		44 [DEPTH]ノブ	A
83 S: Reverb Depth		46 [DEPTH]ノブ	A
111 S: SW		17 ボイスセクション[ON/OFF]スイッチ	B
112 S: Split		21 SPLIT [L R]ボタン	E
113 S: Octave		22 OCTAVE [-2 -1]/[+1 +2]ボタン	F
114 S: Effect Type	33 インサージョンエフェクト切り替えボタン	J	
DELAY REVERB	80 Delay Time	45 [TIME]ノブ	A
	85 Reverb Time	45 [TIME]ノブ	A
	91 All Reverb Depth	46 [DEPTH]ノブ	A
	92 Delay Feedback	45 [FEEDBACK]ノブ	A
	93 All Delay Depth	44 [DEPTH]ノブ	A
	115 Delay SW	42 DELAY [ON/OFF]スイッチ	B
	116 Delay Effect Type	43 [Analog/Digital]切り替えボタン	K
	117 Reverb SW	47 REVERB [ON/OFF]スイッチ	B
	118 Depth Knob Select	41 エフェクトレベル表示切り替えボタン	L

	CC No. (ディスプレイ表示)	コントローラー	対応表*
MASTER EQUALIZER	86 Master EQ SW	50 MASTER EQUALIZER [ON/OFF]ボタン	B
	87 Master EQ High	51 [HIGH]ノブ	C
	88 Master EQ Mid	52 [MID]ノブ	C
	89 Master EQ Freq	53 [FREQUENCY]ノブ	D
	90 Master EQ Low	54 [LOW]ノブ	C
	PEDAL	1 Modulation	
4 Pedal Wah			
5 (Portamento Time)			
6 (Data Entry MSB)			
7 All Volume			
10 (Pan)			
11 Expression			
12 P: Select		18 ボイスカテゴリーセクター	M
		19 ボイスセレクトスイッチ	M
13 P: Volume		23 [VOLUME]ノブ	A
14 P: Tone		24 [TONE]ノブ	A
15 P: Damper Reso		25 DAMPER RESONANCE [ON/OFF]ボタン	B
16 P: Effect SW		26 インサージョンエフェクト[ON/OFF]ボタン	B
17 P: Effect Depth		28 [DEPTH]ノブ	A
18 E: Select		18 ボイスカテゴリーセクター	N
		19 ボイスセレクトスイッチ	N
19 E: Volume		23 [VOLUME]ノブ	A
20 E: Tone		24 [TONE]ノブ	A
21 E: Drive SW		26 インサージョンエフェクト[ON/OFF]ボタン	B
22 E: Drive Depth		28 [DRIVE]ノブ	A
23 E: Effect 1 SW		26 インサージョンエフェクト[ON/OFF]ボタン	B
24 E: Effect 1 Depth		31 [DEPTH]ノブ	A
25 E: Effect 1 Rate		32 [RATE]ノブ	A
26 E: Effect 2 SW		26 インサージョンエフェクト[ON/OFF]ボタン	B
27 E: Effect 2 Depth		34 [DEPTH]ノブ	A
28 E: Effect 2 Speed	35 [SPEED]ノブ	A	
29 S: Select	18 ボイスカテゴリーセクター	O	
	19 ボイスセレクトスイッチ	O	
30 S: Volume	23 [VOLUME]ノブ	A	
31 S: Tone	24 [TONE]ノブ	A	
32 (Bank LSB)			
38 (Data Entry LSB)			
64 Sustain	*		
65 (Portamento)			
66 Sostenuto	*		
67 Soft			
68 S: Effect SW	26 インサージョンエフェクト[ON/OFF]ボタン	B	
71 (Resonance)			
72 S: Release	37 [RELEASE]ノブ	A	
73 S: Attack	35 [ATTACK]ノブ	A	
74 (Cutoff)			
75 S: Effect Depth	39 [DEPTH]ノブ	A	
76 S: Effect Speed	40 [SPEED]ノブ	A	
77 P: Delay Depth	44 [DEPTH]ノブ	A	
78 E: Delay Depth	44 [DEPTH]ノブ	A	
79 S: Delay Depth	44 [DEPTH]ノブ	A	
80 Delay Time	45 [TIME]ノブ	A	
81 P: Reverb Depth	46 [DEPTH]ノブ	A	
82 E: Reverb Depth	46 [DEPTH]ノブ	A	
83 S: Reverb Depth	46 [DEPTH]ノブ	A	
84 (Portamento Ctrl)			
85 Reverb Time	45 [TIME]ノブ	A	

	CC No. (ディスプレイ表示)	コントローラー	対応表*	
PEDAL	86	Master EQ SW	50 MASTER EQUALIZER [ON/OFF] ボタン	B
	87	Master EQ High	51 [HIGH]ノブ	C
	88	Master EQ Mid	52 [MID]ノブ	C
	89	Master EQ Freq	53 [FREQUENCY]ノブ	D
	90	Master EQ Low	54 [LOW]ノブ	C
	91	All Reverb Depth	43 [DEPTH]ノブ	A
	92	Delay Feedback	45 [FEEDBACK]ノブ	A
	93	All Delay Depth	44 [DEPTH]ノブ	A
	94	(Effect 4 Depth)		
	95	(Effect 5 Depth)		
	96	(Data Increment)		
	97	(Data Decrement)		
	98	(NRPN LSB)		
	99	(NRPN MSB)		
	100	(RPN LSB)		
	101	(RPN MSB)		
	102	P: SW	17 ボイスセクション[ON/OFF]スイッチ	B
	103	P: Split	21 SPLIT [L R]ボタン	E
	104	P: Octave	22 OCTAVE [-2 -1]/[+1 +2]ボタン	F
	105	P: Effect Type	27 インサージョンエフェクト切り替えボタン	G
106	E: SW	17 ボイスセクション[ON/OFF]スイッチ	B	
107	E: Split	21 SPLIT [L R]ボタン	E	
108	E: Octave	22 OCTAVE [-2 -1]/[+1 +2]ボタン	F	
109	E: Effect 1 Type	30 インサージョンエフェクト切り替えボタン	H	
110	E: Effect 2 Type	32 インサージョンエフェクト切り替えボタン	I	
111	S: SW	17 ボイスセクション[ON/OFF]スイッチ	B	
112	S: Split	21 SPLIT [L R]ボタン	E	
113	S: Octave	22 OCTAVE [-2 -1]/[+1 +2]ボタン	F	
114	S: Effect Type	30 インサージョンエフェクト切り替えボタン	J	
115	Delay SW	42 DELAY [ON/OFF]スイッチ	B	
116	Delay Effect Type	43 [Analog/Digital]切り替えボタン	K	
117	Reverb SW	47 REVERB [ON/OFF]スイッチ	B	
118	Depth Knob Select	41 エフェクトレベル表示切り替えボタン	L	
---	Live Set Sound +	*		
---	Live Set Sound -	*		
---	Tempo Delay Tap	*		

コントローラー値/パラメーター値対応表

A

Parameter	Controller	
	Transmitted	Recognized
0-127	0-127	0-127

B

Parameter		Controller	
		Transmitted	Recognized
Off	0	0	0-63
On	1	127	64-127

C

Parameter		Controller	
		Transmitted	Recognized
-12dB	52	0-5	0-5
-11dB	53	6-10	6-10
-10dB	54	11-15	11-15
-9dB	55	16-20	16-20
-8dB	56	21-25	21-25
-7dB	57	26-30	26-30
-6dB	58	31-35	31-35
-5dB	59	36-40	36-40
-4dB	60	41-46	41-46
-3dB	61	47-51	47-51
-2dB	62	52-56	52-56
-1dB	63	57-61	57-61

Parameter		Controller	
		Transmitted	Recognized
0dB	64	62-66	62-66
1dB	65	67-71	67-71
2dB	66	72-76	72-76
3dB	67	77-81	77-81
4dB	68	82-87	82-87
5dB	69	88-92	88-92
6dB	70	93-97	93-97
7dB	71	98-102	98-102
8dB	72	103-107	103-107
9dB	73	108-112	108-112
10dB	74	113-117	113-117
11dB	75	118-122	118-122
12dB	76	123-127	123-127

D

Parameter		Controller	
		Transmitted	Recognized
100Hz	14	0-3	0-3
110Hz	15	4-6	4-6
125Hz	16	7-9	7-9
140Hz	17	10-12	10-12
160Hz	18	13-15	13-15
180Hz	19	16-18	16-18
200Hz	20	19-21	19-21
225Hz	21	22-24	22-24
250Hz	22	25-28	25-28
280Hz	23	29-31	29-31
315Hz	24	32-34	32-34
355Hz	25	35-37	35-37
400Hz	26	38-40	38-40
450Hz	27	41-43	41-43
500Hz	28	44-46	44-46
560Hz	29	47-49	47-49
630Hz	30	50-53	50-53
700Hz	31	54-56	54-56
800Hz	32	57-59	57-59
900Hz	33	60-62	60-62
1.0kHz	34	63-65	63-65
1.1kHz	35	66-68	66-68
1.2kHz	36	69-71	69-71
1.4kHz	37	72-74	72-74
1.6kHz	38	75-78	75-78
1.8kHz	39	79-81	79-81
2.0kHz	40	82-84	82-84
2.2kHz	41	85-87	85-87
2.5kHz	42	88-90	88-90
2.8kHz	43	91-93	91-93
3.2kHz	44	94-96	94-96
3.6kHz	45	97-99	97-99
4.0kHz	46	100-102	100-102
4.5kHz	47	103-106	103-106
5.0kHz	48	107-109	107-109
5.6kHz	49	110-112	110-112
6.3kHz	50	113-115	113-115
7.0kHz	51	116-118	116-118
8.0kHz	52	119-121	119-121
9.0kHz	53	122-124	122-124
10kHz	54	125-127	125-127

E

Parameter		Controller	
		Transmitted	Recognized
L&R	0	0	0-42
L	1	63	43-85
R	2	127	86-127

F

Parameter		Controller	
		Transmitted	Recognized
-2	62	0	0-25
-1	63	31	26-51
0	64	63	52-76
+1	65	95	77-102
+2	66	127	103-127

G

Parameter		Controller	
		Transmitted	Recognized
Comp	0	0	0-31
Dist/OD	1	42	32-63
Drive	2	84	64-95
Chorus	3	127	96-127

H

Parameter		Controller	
		Transmitted	Recognized
A.Pan	0	0	0-21
Trem	1	25	22-42
R.Mod	2	50	43-63
T.Wah	3	76	64-85
P.Wah	4	101	86-106
Comp	5	127	107-127

I

Parameter		Controller	
		Transmitted	Recognized
Cho1	0	0	0-21
Cho2	1	25	22-42
Fla	2	50	43-63
Pha1	3	76	64-85
Pha2	4	101	86-106
Pha3	5	127	107-127

J

Parameter		Controller	
		Transmitted	Recognized
Cho/Fla	0	0	0-31
Rotary	1	42	32-63
Trem	2	84	64-95
Dist/OD	3	127	96-127

K

Parameter		Controller	
		Transmitted	Recognized
Analog	0	0	0-42
Digital	1	127	86-127
Tempo	2	63	43-85

L

Parameter		Controller	
		Transmitted	Recognized
All	0	0	0-31
Piano	1	42	32-63
E.Piano	2	84	64-95
Sub	3	127	96-127

M

Parameter			Controller		CC#
			Transmitted	Recognized	
Grand Piano	1	0	1	1	12
	2	1	2	2	12
	3	2	3	3	12
	4	3	4	4	12
	5	57	58	58	12
	6	91	92	92	12
	7	94	95	95	12
	8	95	96	96	12
	9	106	107	107	12
	10	127	1	1	44
	11	128	2	2	44
Upright Piano	1	4	5	5	12
	2	5	6	6	12
	3	107	108	108	12
CP	1	6	7	7	12
	2	7	8	8	12
Special Piano	1	8	9	9	12
	2	9	10	10	12

N

Parameter			Controller	
			Transmitted	Recognized
Rd	1	10	11	11
	2	11	12	12
	3	12	13	13
	4	58	59	59
	5	59	60	60
	6	92	93	93
	7	93	94	94
Wr	1	13	14	14
	2	14	15	15
	3	60	61	61
Clv	1	15	16	16
	2	16	17	17
	3	17	18	18
DX	1	18	19	19
	2	19	20	20
	3	20	21	21
	4	21	22	22
	5	22	23	23
	6	23	24	24

O

Parameter	Controller		
		Transmitted	Recognized
Pad/Strings	1	24	25
	2	25	26
	3	26	27
	4	27	28
	5	28	29
	6	29	30
	7	30	31
	8	31	32
	9	61	62
	10	62	63
	11	63	64
	12	64	65
	13	65	66
	14	66	67
	15	67	68
	16	68	69
	17	69	70
	18	96	97
	19	97	98
	20	98	99
	21	99	100
	22	100	101
	23	101	102
	24	108	109
	25	109	110
	26	110	111
	27	111	112
	28	112	113
	29	113	114
Organ	1	32	33
	2	33	34
	3	34	35
	4	35	36
	5	36	37
	6	37	38
	7	38	39
	8	39	40
	9	40	41
	10	41	42
	11	102	103
	12	114	115
Chromatic Perc	1	42	43
	2	43	44
	3	44	45
	4	45	46
	5	46	47
	6	47	48
	7	48	49
	8	70	71
	9	71	72
	10	72	73
	11	73	74
Others	1	49	50
	2	50	51
	3	51	52
	4	52	53
	5	53	54
	6	54	55
	7	55	56
	8	56	57
	9	74	75
	10	75	76
	11	76	77
	12	77	78
	13	78	79
	14	79	80
	15	80	81
	16	81	82
	17	82	83

Parameter	Controller		
		Transmitted	Recognized
18	83	84	84
19	84	85	85
20	85	86	86
21	86	87	87
22	87	88	88
23	88	89	89
24	89	90	90
25	90	91	91
26	103	104	104
27	104	105	105
28	105	106	106
29	115	116	116
30	116	117	117
31	117	118	118
32	118	119	119
33	119	120	120
34	120	121	121
35	121	122	122
36	122	123	123
37	123	124	124
38	124	125	125
39	125	126	126
40	126	127	127

MIDI Data Format

(1) TRANSMIT FLOW

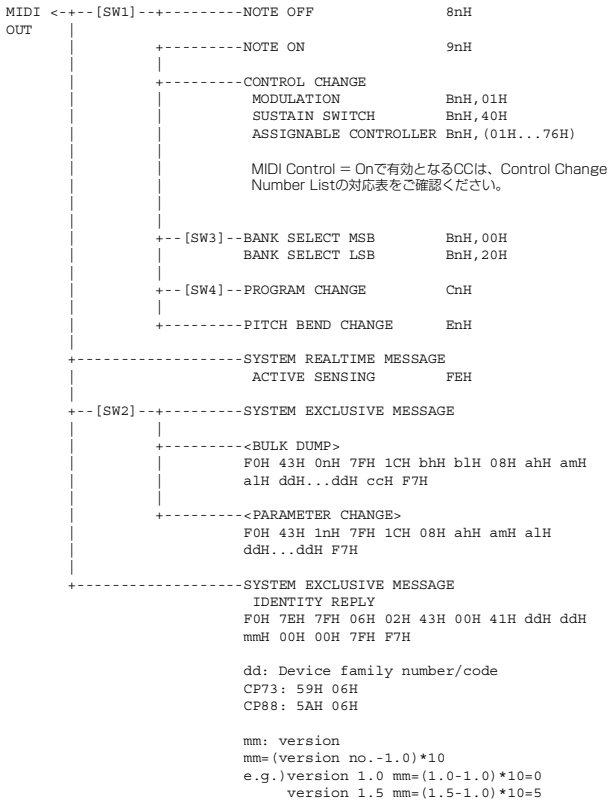

- [SW1] MIDI Transmit Channel
Part Zone Switch = on のときは、Zone Transmit Channel に従います。それ以外の場合は、MIDI Transmit Channel に従います。
- [SW2] SYSTEM MIDI Device Number
allのときは、1で送信されます。
- [SW3] SYSTEM Bank Select Switch
- [SW4] SYSTEM Program Change Switch

(2) RECEIVE FLOW

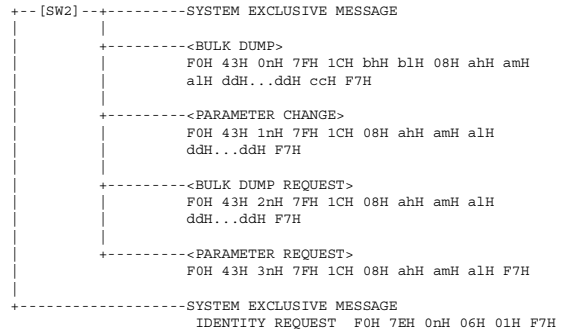
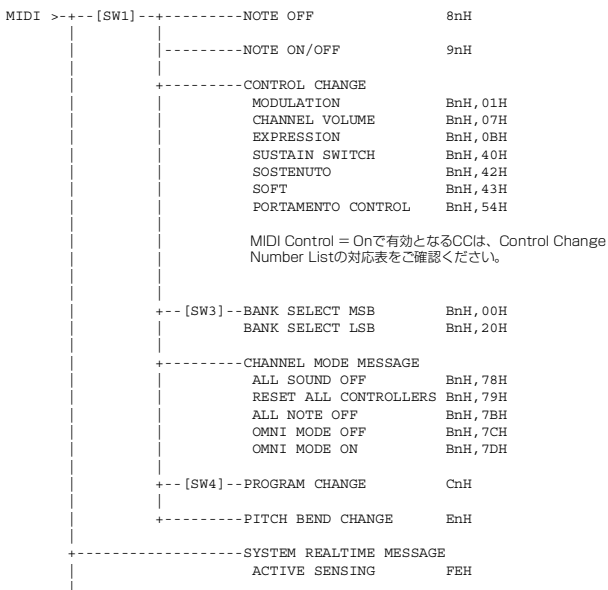

- [SW1] MIDI Receive Channel に従う。
- [SW2] SYSTEM MIDI Device Number
- [SW3] SYSTEM Bank Select Switch
- [SW4] SYSTEM Program Change Switch

(3) TRANSMIT/RECEIVE DATA

(3-1) CHANNEL VOICE MESSAGES

(3-1-1) NOTE OFF

STATUS	1000nnnn (9nH)	n=0-15 CHANNEL NUMBER
NOTE No.	0kkkkkkk	k=0 (C-2) -127 (G8)
VELOCITY	0vvvvvvv	送信時 v=64

(3-1-2) NOTE ON/OFF

STATUS	1000nnnn (8nH)	n=0-15 CHANNEL NUMBER
NOTE No.	0kkkkkkk	k=0 (C-2) -127 (G8)
VELOCITY NOTE ON	0vvvvvvv (v≠0)	
NOTE OFF	0vvvvvvv (v=0)	

(3-1-3) CONTROL CHANGE

STATUS	1011nnnn (BnH)	n=0-15 CHANNEL NUMBER
CONTROL NUMBER	0ccccccc	
CONTROL VALUE	0vvvvvvv	

*送信するCONTROL NUMBER

c=0	BANK SELECT MSB	;v=0-127	*1
c=32	BANK SELECT LSB	;v=0-127	*1
c=1	MODULATION	;v=0-127	
c=64	SUSTAIN SWITCH	;v=0-127	*3
c=1...118	ASSIGNABLE CONTROLLER	;v=0-127	*2

*受信するCONTROL NUMBER

c=0	BANK SELECT MSB	;v=0-127	*1
c=32	BANK SELECT LSB	;v=0-127	*1
c=1	MODULATION	;v=0-127	
c=7	CHANNEL VOLUME	;v=0-127	
c=11	EXPRESSION	;v=0-127	
c=64	SUSTAIN SWITCH	;v=0-127	
c=66	SOSTENUTO	;v=0-63:OFF, 64-127:ON	
c=67	SOFT	;v=0-127	
c=84	PORTAMENTO CONTROL	;v=0-127	

*1 BANK SELECTとPROGRAMの関係

	CATEGORY	MSB	LSB	PROGRAM No.
Live Set Page 1		63	0	0..7
:	:	:	:	:
Live Set Page 20		63	19	0..7

*2 ASSIGNABLE CONTROLLERのDEFAULT CONTROL NUMBERは、以下の通りです。

FOOT CONTROLLER 1	11
FOOT CONTROLLER 2	4
FOOT SWITCH Live Set Inc	

*3 サステインペダルの設定が「FC3 (half on)」以外の場合、サステインペダルの操作によって送信されるメッセージの値は0 (オフ)と127 (オン)のみとなります。

Bank Selectの動作は、すべてProgram Changeを受信したときに発生します。Bank Select、Program Changeは、サポートしている番号以外のものは無視されます。

(3-1-4) PROGRAM CHANGE

STATUS	1100nnnn (CnH)	n=0-15 CHANNEL NUMBER
PROGRAM NUMBER	0000pppp	p=0-7

(3-1-5) PITCH BEND CHANGE

STATUS	1110nnnn (EnH)	n=0-15 CHANNEL NUMBER
LSB	0vvvvvvv	PITCH BEND CHANGE LSB
MSB	0vvvvvvv	PITCH BEND CHANGE MSB

送信の分解能は7 bitです。

(3-2) CHANNEL MODE MESSAGES

```

STATUS          1011nnnn (BnH)    n=0-15 CHANNEL NUMBER
CONTROL NUMBER  0ccccccc          c=CONTROL NUMBER
CONTROL VALUE   0vvvvvvvv        v=DATA VALUE
    
```

(3-2-1) ALL SOUND OFF (CONTROL NUMBER = 78H, DATA VALUE = 0)

該当チャンネルの発音中の音をすべて消音します。ノート・オンやホールド・オンなどのチャンネルメッセージの状態も消去します。

(3-2-2) RESET ALL CONTROLLERS (CONTROL NUMBER = 79H, DATA VALUE = 0)

以下のコントローラーの設定値をリセットします。

```

PITCH BEND CHANGE 0 (中央)
MODULATION         0 (最小)
EXPRESSION        127 (最大)
PEDAL WAH         0 (最小)
SUSTAIN SWITCH    0 (オフ)
SOSTENUTO SWITCH  0 (オフ)
SOFT              0 (オフ)
PORTAMENTO CONTROL 予約したノート番号のリセット
    
```

以下のデータは変更されません。

```

PROGRAM CHANGE, BANK SELECT MSB/LSB, VOLUME
    
```

(3-2-3) ALL NOTE OFF (CONTROL NUMBER = 7BH, DATA VALUE = 0)

該当チャンネルのオンしているノートをすべてオフします。ただし、サステイン、あるいはソステヌートがオンの場合は、それらがオフになるまで発音は終了しません。

(3-2-4) OMNI MODE OFF (CONTROL NUMBER = 7CH, DATA VALUE = 0)

ALL NOTE OFF を受信したときと同じ処理を行いません。

(3-2-5) OMNI MODE ON (CONTROL NUMBER = 7DH, DATA VALUE = 0)

ALL NOTE OFF を受信したときと同じ処理を行いません。

(3-4) SYSTEM REAL TIME MESSAGES

(3-4-1) ACTIVE SENSING

```

STATUS          11111110 (FEH)
    
```

約200 msecごとに送信します。

このCODEを一度受信すると、SENSINGを開始します。約350 msec以上の間、STATUSもDATAも来ないときは、MIDI受信BUFFERをCLEARし、発音している音を強制的にOFFにします。

(3-5) SYSTEM EXCLUSIVE MESSAGE

(3-5-1) UNIVERSAL NON REALTIME MESSAGE

(3-5-1-1) IDENTITY REQUEST (受信のみ)

F0H 7EH 0nH 06H 01H F7H (nはDevice No.、本機はomniで受信します。)

(3-5-1-2) IDENTITY REPLY (送信のみ)

F0H 7EH 7FH 06H 02H 43H 00H 41H ddH ddH mmH 00H 00H 7FH F7H

dd: Device family number/code

CP73: 59H 06H

CP88: 5AH 06H

mm: version

mm=(version no.-1.0)*10

e.g.) version 1.0 mm=(1.0-1.0)*10=0

version 1.5 mm=(1.5-1.0)*10=5

(3-5-2) UNIVERSAL REALTIME MESSAGE

(3-5-3) PARAMETER CHANGE

(3-5-3-1) NATIVE PARAMETER CHANGE, MODE CHANGE

```

11110000 F0 Exclusive status
01000011 43 YAMAHA ID
0001nnnn 1n Device Number
01111111 7F Group ID High
00011100 1C Group ID Low
00000010 08 Model ID
0aaaaaaaa aaaaaaaa Address High
0aaaaaaaa aaaaaaaa Address Mid
0aaaaaaaa aaaaaaaa Address Low
0ddddddd dddddddd Data
|
11110111 F7 End of Exclusive
    
```

Data Sizeが2以上のパラメータはそのSize分データを送信します。Addressは、MIDI Data Tableをご参照ください。

(3-5-4) BULK DUMP

```

11110000 F0 Exclusive status
01000011 43 YAMAHA ID
0000nnnn 0n Device Number
01111111 7F Group ID High
00011100 1C Group ID Low
0bbbbbbb bbbbbbbb Byte Count
0bbbbbbb bbbbbbbb Byte Count
00000010 08 Model ID
0aaaaaaaa aaaaaaaa Address High
0aaaaaaaa aaaaaaaa Address Mid
0aaaaaaaa aaaaaaaa Address Low
0 Data
|
0ccccccc cccccccc Check-sum
11110111 F7 End of Exclusive
    
```

AddressおよびByte Countは、MIDI Data Tableをご参照ください。Check sumは、Byte Count、Start Address、Data、Check-sum自身を加算した値の下位7bitがゼロになる値です。

(3-5-5) DUMP REQUEST

```

11110000 F0 Exclusive status
01000011 43 YAMAHA ID
0010nnnn 2n Device Number
01111111 7F Group ID High
00011100 1C Group ID Low
00000010 08 Model ID
0aaaaaaaa aaaaaaaa Address High
0aaaaaaaa aaaaaaaa Address Mid
0aaaaaaaa aaaaaaaa Address Low
11110111 F7 End of Exclusive
    
```

Addressは、MIDI Data Tableをご参照ください。

(3-5-6) PARAMETER REQUEST

```

11110000 F0 Exclusive status
01000011 43 YAMAHA ID
0011nnnn 3n Device Number
01111111 7F Group ID High
00011100 1C Group ID Low
00000010 08 Model ID
0aaaaaaaa aaaaaaaa Address High
0aaaaaaaa aaaaaaaa Address Mid
0aaaaaaaa aaaaaaaa Address Low
11110111 F7 End of Exclusive
    
```

Addressは、MIDI Data Tableをご参照ください。

(4) Keyboardと音源部との構成図

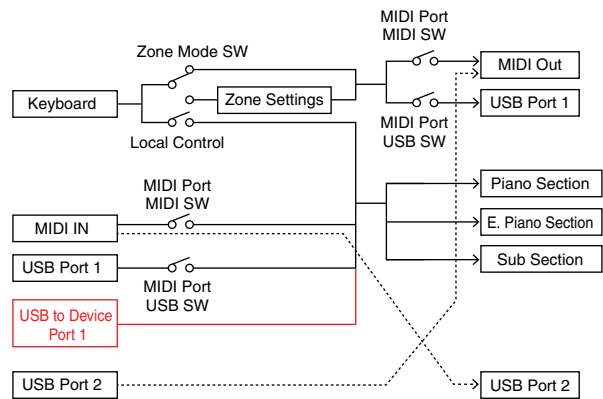

USB Port 2 is enabled when 'MIDI Port MIDI SW = OFF' and 'MIDI Port USB SW = ON'

ALL SOUND OFFは、MIDI、本体の区別なく、該当チャンネルすべての発音を消去します。MIDIで受信したALL NOTE OFFは、該当チャンネルでMIDIにより発音されたノートのみをオフします。

USB to Device Port 1は受信のみで、送信はしません。

MIDI Data Table

Bank Select

MSB	(HEX)	LSB	(HEX)	Program No.	Type	Memory	Description
63	3F	0	00	0-7	Live Set Sound	User	Live Set Page 1
		1	01	0-7		User	Live Set Page 2
		2	02	0-7		User	Live Set Page 3
		3	03	0-7		User	Live Set Page 4
		4	04	0-7		User	Live Set Page 5
		5	05	0-7		User	Live Set Page 6
		6	06	0-7		User	Live Set Page 7
		7	07	0-7		User	Live Set Page 8
		8	08	0-7		User	Live Set Page 9
		9	09	0-7		User	Live Set Page 10
		10	0A	0-7		User	Live Set Page 11
		11	0B	0-7		User	Live Set Page 12
		12	0C	0-7		User	Live Set Page 13
		13	0D	0-7		User	Live Set Page 14
		14	0E	0-7		User	Live Set Page 15
		15	0F	0-7		User	Live Set Page 16
		16	10	0-7		User	Live Set Page 17
		17	11	0-7		User	Live Set Page 18
		18	12	0-7		User	Live Set Page 19
		19	13	0-7		User	Live Set Page 20
		20	14	0-7		User	Live Set Page 21
		21	15	0-7		User	Live Set Page 22
		22	16	0-7		User	Live Set Page 23
		23	17	0-7		User	Live Set Page 24
		24	18	0-7		User	Live Set Page 25
		25	19	0-7		User	Live Set Page 26
		26	1A	0-7		User	Live Set Page 27
		27	1B	0-7		User	Live Set Page 28
		28	1C	0-7		User	Live Set Page 29
		29	1D	0-7		User	Live Set Page 30
		30	1E	0-7		User	Live Set Page 31
		31	1F	0-7		User	Live Set Page 32
		32	20	0-7		User	Live Set Page 33
		33	21	0-7		User	Live Set Page 34
		34	22	0-7		User	Live Set Page 35
		35	23	0-7		User	Live Set Page 36
		36	24	0-7		User	Live Set Page 37
		37	25	0-7		User	Live Set Page 38
		38	26	0-7		User	Live Set Page 39
39	27	0-7	User	Live Set Page 40			

Bulk Dump Block

Top Addressは、Bulk Dumpで指定されるブロックの先頭アドレスを示します。
 Byte Countは、Bulk Dumpのブロックに含まれるデータサイズを示します。
 Live Set SoundのBulk HeaderからBulk FooterまでのBlockは、順序は関係なく、すべて揃わなくても受信します。
 ただし、本来含まれないBlockが割り込んだ場合は、無効となります。
 1 Live Set Soundのリクエストは、対応するBulk Headerのアドレスを指定してください。
 以下の表のBulk Headerの部分のpp, nについては、MIDI PARAMETER CHANGE TABLE (BULK CONTROL)をご参照ください。

Group Number = 7F 1C, Model ID = 08

Parameter Block	Description	Byte Count		Top Address		
		Dec	Hex	High	Mid	Low
System	System	48	30	20	00	00
	Master EQ	20	14	20	40	00
	Contents Unlock			20	70	00
Live Set Sound	Bulk Header	0	00	0E	pp	0n
	Soundmodo Format Version	4	04	00	7F	00
Common		48	30	46	00	00
	Additional	48	30	46	01	00
Zone	Zone 1	16	10	4A	00	00
	:				:	
	Zone 4				03	
Section	Piano Common	24	18	50	00	00
	E.Piano Common				01	
	Sub Common				02	
	Piano Specific	28	1C	50	10	00
	E.Piano Specific				11	
	Sub Specific				12	
	Piano Additional	16	10	50	20	00
	E.Piano Additional				21	
	Sub Additional				22	
Master EQ	20	14	20	40	00	
Bulk Footer	0	00	0F	pp	0n	

Message Type	Data
Parameter Change	F0, 43, 1n, gh, gl, id, ah, am, al, dt, ... F7
Parameter Request	F0, 43, 3n, gh, gl, id, ah, am, al F7
Bulk Dump	F0, 43, 0n, gh, gl, bh, bl, id, ah, am, al, dt, ..., cc, F7
Bulk Request	F0, 43, 2n, gh, gl, id, ah, am, al, F7

n: Device Number
 gh: Group Number High
 gl: Group Number Low
 bh: Byte Count High
 bl: Byte Count Low
 id: Model ID
 ah: Parameter Address High
 am: Parameter Address Middle
 al: Parameter Address Low
 dt: Data
 cc: Data Checksum

Parameter Base Address

Group Number = 7F 1C, Model ID = 08

Parameter Block	Top Address			Description
	High	Mid	Low	
	System	20	00	
BULK CONTROL	20	40	00	Master EQ
	00	7F	00	Soundmodo Format Version
	0E	00	00	Header
STORE TO FLASH	0F	00	00	Footer
	0D	00	00	Store To Flash
Live Set Sound	46	00	00	Common
	46	01	00	Additional
Zone	4A	zz	00	Zone (zz: 00 - 03)
	Section	50	0p	00
50		1p	00	Specific
50		2p	00	Additional

MIDI PARAMETER CHANGE TABLE (BULK CONTROL)

Group Number = 7F 1C, Model ID = 08

Address			Size	Data Range (HEX)	Parameter Name	Description	Default (HEX)	Notes
High	Mid	Low						
0E	pp	0n	1	-	Bulk Header	Live Set Sound User (pp = 0 - 39, n = 0 - 7)	-	
	7F	00	1	-		Current Sound Buffer	-	
0F	pp	0n	1	-	Bulk Footer	Live Set Sound User (pp = 0 - 39, n = 0 - 7)	-	
	7F	00	1	-		Current Sound Buffer	-	

Address			Size	Data Range	Parameter Name	Description	Default (HEX)	Notes
High	Mid	Low						
		29	1	00 - 01	Live Set View Mode	Close, Keep	00	
		2A	1	00 - 27	Power On Page	1 - 40	00	
		2B	1	00 - 07	Power On Sound	1 - 8	00	
		2C	1	00 - 79	FS Control Number	Off, 1 - 118, 119 (Live Set Inc), 120 (Live Set Dec), 121 (Tempo Delay Tap Tempo)	77	
		2D	1		reserved			
		2E	1	00 - 7F	USB Audio Volume	0 - 127	40	
		2F	1	00 - 02	Sustain Pedal Select	FC3 Half On, FC3 HalfOff, FC4/5	00	

TOTAL SIZE = 48

30 (HEX)

SYSTEM System Common

Group Number = 7F 1C, Model ID = 08

Address			Size	Data Range	Parameter Name	Description	Default (HEX)	Notes
High	Mid	Low						
20	00	00	1		reserved			
		01	1		reserved			
		02	4	00 - 00 00 - 07 00 - 0F 00 - 0F	Master Tune	-102.4 - +102.3 [cent] 1st bit3-0: bit15-12 2nd bit3-0: bit11-8 3rd bit3-0: bit 7-4 4th bit3-0: bit 3-0	00 04 00 00	
		06	1	3D - 43	Keyboard Octave Shift	-3 - 0 - +3	40	
		07	1	34 - 4C	Keyboard Transpose	-12 - +12 [semitones]	40	
		08	1	00 - 01	Controller Reset	Hold, Reset	01	
		09	1	00 - 01	Local Switch	Off, On	01	
		0A	1	00 - 0F, 7F	Tx Channel	1 - 16, Off	00	
		0B	1	00 - 10	Rx Channel	1 - 16, All	00	
		0C	1	00 - 02	MIDI Control	Off, On, Invert	00	
		0D	1	00 - 01	Section SW Mode	Realtime, Next Key	00	
		0E	1	38 - 48	Output Gain	-24 - 0 - +24 [dB]	40	3[dB] 刻み
		0F	1		reserved			
		10	1	00 - 04	Keyboard Velocity Curve	Normal, Soft, Hard, Wide, Fixed	00	
		11	1	01 - 7F	Keyboard Fixed Velocity	1 - 127	40	
		12	1	00 - 01	Transmit/Receive Bank Select	Off, On	01	
		13	1	00 - 01	Transmit/Receive Program Change	Off, On	01	
		14	1		reserved			
		15	1	00 - 01	MIDI In/Out	USB Thru, In/Out	01	
		16	1	00 - 01	USB In/Out	Off, On	01	
		17	1		reserved			
		18	1		reserved			
		19	1	00 - 01	Display Lights Ins Effect	Off, On	01	
		1A	1	00 - 01	Display Lights Section	Off, On	01	
		1B	1	00 - 01	Display Lights LCD	Off, On	01	
		1C	1		reserved			
		1D	1		reserved			
		1E	1	00 - 01	Value Indication	Off, On	01	
		1F	1		reserved			
		20	1	00 - 01	SW Direction	Default, Reverse	00	
		21	1		reserved			
		22	1	01 - 3F	LCD Contrast	1 - 63	20	
		23	1	00 - 01	Panel Lock Live Set	Off, On	01	
		24	1	00 - 01	Panel Lock Section	Off, On	01	
		25	1	00 - 01	Panel Lock Effect	Off, On	01	
		26	1	00 - 01	Panel Lock Master EQ	Off, On	01	
		27	1		reserved			
		28	1	00 - 01	Section Hold	Disable, Enable	00	

System MEQ

Group Number = 7F 1C, Model ID = 08

Address			Size	Data Range	Parameter Name	Description	Default (HEX)	Notes
High	Mid	Low						
20	40	00	1	34 - 4C	EQ Gain1	-12dB - +12dB	40	
		01	1		reserved			
		02	1		reserved			
		03	1		reserved			
		04	1		reserved			
		05	1		reserved			
		06	1		reserved			
		07	1		reserved			
		08	1	34 - 4C	EQ Gain3	-12dB - +12dB	40	
		09	1	0E - 36	EQ Frequency3	100Hz - 10kHz	1C	
		0A	1		reserved			
		0B	1		reserved			
		0C	1		reserved			
		0D	1		reserved			
		0E	1		reserved			
		0F	1		reserved			
		10	1	34 - 4C	EQ Gain5	-12dB - +12dB	40	
		11	1		reserved			
		12	1		reserved			
		13	1	00 - 01	EQ On/Off	Off, On	00	

TOTAL SIZE = 20

14 (HEX)

Soundmondo Format Version

Group Number = 7F 1C, Model ID = 08

Address			Size	Data Range	Parameter Name	Description	Default (HEX)	Notes
High	Mid	Low						
00	7F	00	1	00 - 7F	Soundmondo Format Version Major		01	
			1	00 - 7F	Soundmondo Format Version Minor		04	
			1	00 - 7F	Soundmondo Format Version Bugfix		00	
			1		reserved		00	

TOTAL SIZE = 4

04 (HEX)

LIVE SET SOUND

Live Set Sound Common

Group Number = 7F 1C, Model ID = 08

Address			Size	Data Range	Parameter Name	Description	Default (HEX)	Notes
High	Mid	Low						
46	00	00	1	20 - 7F	Live Set Sound Name 1	32 - 127 (ASCII)	49	'i'
		01	1	20 - 7F	Live Set Sound Name 2	32 - 127 (ASCII)	6E	'n'
		02	1	20 - 7F	Live Set Sound Name 3	32 - 127 (ASCII)	69	'i'
		03	1	20 - 7F	Live Set Sound Name 4	32 - 127 (ASCII)	74	't'
		04	1	20 - 7F	Live Set Sound Name 5	32 - 127 (ASCII)	20	''
		05	1	20 - 7F	Live Set Sound Name 6	32 - 127 (ASCII)	53	'S'
		06	1	20 - 7F	Live Set Sound Name 7	32 - 127 (ASCII)	6F	'o'
		07	1	20 - 7F	Live Set Sound Name 8	32 - 127 (ASCII)	75	'u'
		08	1	20 - 7F	Live Set Sound Name 9	32 - 127 (ASCII)	6E	'n'
		09	1	20 - 7F	Live Set Sound Name 10	32 - 127 (ASCII)	64	'd'
		0A	1	20 - 7F	Live Set Sound Name 11	32 - 127 (ASCII)	20	
		0B	1	20 - 7F	Live Set Sound Name 12	32 - 127 (ASCII)	20	
		0C	1	20 - 7F	Live Set Sound Name 13	32 - 127 (ASCII)	20	
		0D	1	20 - 7F	Live Set Sound Name 14	32 - 127 (ASCII)	20	
		0E	1	20 - 7F	Live Set Sound Name 15	32 - 127 (ASCII)	20	
		0F	1	02	Bulk Format Version	2	02	2固定
		10	1		reserved			
		11	1	00 - 01	Zone Mode Switch	Off, On	00	
		12	1	00 - 01	Advanced Zone Mode Switch	Off, On	00	
		13	1	00 - 01	Live Set EQ Mode Switch	Off, On	00	
		14	1	00 - 3F, 41, 43 - 77	Modulation Lever Assign	0 - 63, 65, 67 - 118, 119 (USB Audio Volume)	01	sustain (=64), sostenuto (=66)は選択不可
		15	1	34 - 4C	TG Transpose	-12 - +12	40	
		16	1	01 - 7F	Split Point	C#-2 - G8	37	
		17	1	00 - 7F	Modulation Lever Limit Low	0 - 127	00	
		18	1	00 - 7F	Modulation Lever Limit High	0 - 127	7F	
		19	1	00 - 3F, 41, 43 - 77	FC1 Assign	0 - 63, 65, 67 - 118, 119 (USB Audio Volume)	0B	sustain (=64), sostenuto (=66)は選択不可
		1A	1	00 - 3F, 41, 43 - 77	FC2 Assign	0 - 63, 65, 67 - 118, 119 (USB Audio Volume)	04	sustain (=64), sostenuto (=66)は選択不可
		1B	1	00 - 7F	FC1 Limit Low	0 - 127	00	
		1C	1	00 - 7F	FC1 Limit High	0 - 127	7F	
		1D	1	00 - 7F	FC2 Limit Low	0 - 127	00	
		1E	1	00 - 7F	FC2 Limit High	0 - 127	7F	
		1F	1		reserved			
		20	1	00 - 03	Depth Knob Section Select	All, Piano, E.Piano, Sub	00	
		21	1	00 - 7F	Piano Touch Sensitivity Depth	0 - 127	40	
		22	1	00 - 7F	E.Piano Touch Sensitivity Depth	0 - 127	40	
		23	1	00 - 7F	Sub Touch Sensitivity Depth	0 - 127	40	
		24	1	00 - 01	Delay Switch	Off, On	01	
		25	1	00 - 02	Delay Type	Analog, Digital, Tempo	00	
		26	1	00 - 7F	Delay Feedback	0 - 127	40	

Address			Size	Data Range	Parameter Name	Description	Default (HEX)	Notes
High	Mid	Low						
		27	1	00 - 7F	Delay Time	0 - 127	40	
		28	1	00 - 01	Reverb Switch	Off, On	01	
		29	1	00 - 7F	Piano Touch Sensitivity Offset	0 - 127	40	
		2A	1	00 - 7F	E.Piano Touch Sensitivity Offset	0 - 127	40	
		2B	1	00 - 7F	Reverb Time	0 - 127	40	
		2C	1	00 - 7F	Sub Touch Sensitivity Offset	0 - 127	40	
		2D	1	00 - 7F	Piano Pitch Modulation Speed	0 - 127	40	
		2E	1	00 - 7F	E.Piano Pitch Modulation Speed	0 - 127	40	
		2F	1	00 - 7F	Sub Pitch Modulation Speed	0 - 127	40	

TOTAL SIZE = 48 30 (HEX)

Live Set Sound Additional

Group Number = 7F 1C, Model ID = 08

Address			Size	Data Range	Parameter Name	Description	Default (HEX)	Notes
High	Mid	Low						
46	01	00	1		reserved			
		01	1	00 - 0E	Tempo Delay Time	1/32 Tri., 1/64 Dot., 1/32, 1/16 Tri., 1/32 Dot., 1/16, 1/8 Tri., 1/16 Bot, 1/8, 1/4 Tri., 1/8 Dot., 1/4, 1/2 Tri., 1/4 Dot., 1/2	0B	
		02	2	01 - 12, 00 - 7F	Tempo	42.0 - 240.0	07 04	
		04	1		reserved			
		05	1		reserved			
		06	1		reserved			
		07	1		reserved			
		08	1		reserved			
		09	1		reserved			
		0A	1		reserved			
		0B	1		reserved			
		0C	1		reserved			
		0D	1		reserved			
		0E	1		reserved			
		0F	1		reserved			

TOTAL SIZE = 16 10 (HEX)

ZONE

Group Number = 7F 1C, Model ID = 08

Address			Size	Data Range	Parameter Name	Description	Default (HEX)	Notes
High	Mid	Low						
4A	zz	00	1	00 - 01	Zone Switch	off, on	00 - 01	Default は Zone1 のみ ON
		01	1	00 - 0F	Transmit Channel	Ch1 - 16	00 - 03	Default は Zone1 (0), Zone2(1), Zone3(2), Zone4(3)
		02	1	3D - 43	Transpose (Octave)	-3 - +3	40	
		03	1	35 - 4B	Transpose (Semitone)	-11 - +11	40	
		04	1	00 - 7F	Note Limit Low	C-2 - G8	00	上限は Note Limit Highでリミット
		05	1	00 - 7F	Note Limit High	C-2 - G8	7F	下限は Note Limit Lowでリミット
		06	1		reserved			
		07	1	00 - 7F	MIDI Volume	0 - 127	64	
		08	1	00 - 7F	MIDI Pan	L64 - C - R63	40	
		09	1	00 - 7F	MIDI Bank MSB	000 - 127	00	
		0A	1	00 - 7F	MIDI Bank LSB	000 - 127	00	
		0B	1	00 - 7F	MIDI Program Number	001 - 128	00	
		0C	1	00 - 1F	Transmit Bank Select Transmit Program Change Transmit Volume Transmit Pan Transmit Note	bit0: off, on Bank Select bit1: off, on Program Change bit2: off, on Volume bit3: off, on Pan bit4: off, on Note	1F	Volumeを offにしたときは CC# 11 (Expression)も出力しない
		0D	1	00 - 3F	Transmit PB Transmit MW Transmit FC1 Transmit FC2 Transmit FS Transmit Sus	bit0: off, on PB bit1: off, on MW bit2: off, on FC1 bit3: off, on FC2 bit4: off, on FS bit5: off, on Sus	3F	
		0E	1		reserved			
		0F	1		reserved			

TOTAL SIZE = 16 10 (HEX)

zz = Zone Number
00 - 03 (HEX)

SECTION Section Common

Group Number = 7F 1C, Model ID = 08

Address			Size	Data Range	Parameter Name	Description	Default (HEX)	Notes
High	Mid	Low						
50	0p	00	1	00 - 0B	Current Category		00	
		01	1	00 - 7F	Category 1 Voice Number		00	
		02	1	00 - 7F	Category 2 Voice Number		00	
		03	1	00 - 7F	Category 3 Voice Number		00	
		04	1	00 - 7F	Category 4 Voice Number		00	
		05	1	00 - 7F	Advanced Sound Mode Voice Number		00	7Fの場合は Advanced Sound Mode Extra Voice Numberを加算した値が音色番号になる
		06	1	00 - 01	Advanced Sound Mode Switch	Off, On	00	
		07	1	00 - 01	Section Switch	Off, On	01	
		08	1	00 - 02	Split Mode	L&R, L, R	00	
		09	1	3E - 42	Octave Shift	-2 - 0 - +2	40	
		0A	1	00 - 7F	Section Volume	0 - 127	7F (Piano), 40 (EP, Sub)	
		0B	1	00 - 7F	Tone	0 - 127	40	
		0C	1	00 - 02	Advanced Sound Mode Extra Voice Number		00	Advanced Sound Mode Voice Numberが 7F以外のときは無効
		0D	1	28 - 58	Pitch Bend Range	-24 - 0 - +24	42	
		0E	1		reserved			
		0F	1	00 - 7F	Pitch Modulation Depth	0 - 127	00 (Piano), 0A (Sub)	
		10	1		reserved			
		11	1	00 - 01	Receive Expression	Off, On	01	
		12	1	00 - 01	Receive Sustain	Off, On	01	
		13	1	00 - 01	Receive Sostenuto	Off, On	01	
		14	1	00 - 01	Receive Soft	Off, On	01	
		15	1		reserved			
		16	1	00 - 7F	Delay Depth	0 - 127	00	
		17	1	00 - 7F	Reverb Depth	0 - 127	00	

TOTAL SIZE = 24 18 (HEX)

0p = Section Number
00 = Piano, 01 = E.Piano, 02 = Sub

Section Specific

Group Number = 7F 1C, Model ID = 08

Address			Size	Data Range	Parameter Name	Description	Default (HEX)	Notes
High	Mid	Low						
50	1p	00	1	00 - 01	Piano Damper Resonance Switch	Off, On	00	Piano Sectionのみ有効
		01	1	1	Bulk Format Version	1	01	1固定
		02	1	00 - 7F	Piano Damper Resonance Damper Control	0 - 127	00	Piano Sectionのみ有効
		03	1	01 - 7F	Piano Damper Resonance Dry/Wet Balance	D63<W - D<W63	19	Piano Sectionのみ有効
		04	1	00 - 01	Piano Effect Switch	Off, On	00	Piano Sectionのみ有効
		05	1	00 - 03	Piano Effect Type	Comp, Dist/OD, Drive, Chorus	00	Piano Sectionのみ有効
		06	1	00 - 7F	Piano Effect Depth	0 - 127	40	Piano Sectionのみ有効
		07	1		reserved			
		08	1	00 - 01	E.Piano Effect 1 Switch	Off, On	00	E.Piano Sectionのみ有効
		09	1	00 - 05	E.Piano Effect 1 Type	A.Pan, Trem, R.Mod, T.Wah, P.Wah, Comp	00	E.Piano Sectionのみ有効
		0A	1	00 - 7F	E.Piano Effect 1 Depth	0 - 127	40	E.Piano Sectionのみ有効
		0B	1	00 - 7F	E.Piano Effect 1 Rate	0 - 127	40	E.Piano Sectionのみ有効
		0C	1	00 - 01	E.Piano Effect 2 Switch	Off, On	00	E.Piano Sectionのみ有効
		0D	1	00 - 05	E.Piano Effect 2 Type	Cho1, Cho2, Fla, Pha1, Pha2, Pha3	00	E.Piano Sectionのみ有効
		0E	1	00 - 7F	E.Piano Effect 2 Depth	0 - 127	40	E.Piano Sectionのみ有効
		0F	1	00 - 7F	E.Piano Effect 2 Speed	0 - 127	40	E.Piano Sectionのみ有効
		10	1	00 - 01	E.Piano Drive Switch	Off, On	00	E.Piano Sectionのみ有効
		11	1	00 - 7F	E.Piano Drive	0 - 127	40	E.Piano Sectionのみ有効
		12	1		reserved			
		13	1		reserved			
		14	1	00 - 01	Sub Effect Switch	Off, On	00	Sub Sectionのみ有効
		15	1	00 - 03	Sub Effect Type	Cho/Fla, Rotary, Trem, Dist/OD	00	Sub Sectionのみ有効
		16	1	00 - 7F	Sub Effect Depth	0 - 127	40	Sub Sectionのみ有効
		17	1	00 - 7F	Sub Effect Speed	0 - 127	40	Sub Sectionのみ有効
		18	1	00 - 7F	Sub Attack	0 - 127	40	Sub Sectionのみ有効
		19	1	00 - 7F	Sub Release	0 - 127	40	Sub Sectionのみ有効
		1A	1		reserved			
		1B	1		reserved			

TOTAL SIZE = 28 1C (HEX)

1p = Section Number
10 = Piano, 11 = E.Piano, 12 = Sub

Section Additional

Group Number = 7F 1C, Model ID = 08

Address			Size	Data Range	Parameter Name	Description	Default (HEX)	Notes
High	Mid	Low						
50	2p	00	1		reserved			
		01	1	00 - 01	Mono/Poly	Mono, Poly	01	
		02	1	00 - 01	Portamento Switch	Off, On	00	Mono/Poly = Polyのときは無効
		03	1	00 - 7F	Portamento Time	0 - 127	40	//
		04	1	00 - 01	Portamento Mode	Fingered, Full-time	01	//
		05	1	00 - 01	Portamento Time Mode	Rate, Time	00	//
		06	1		reserved			
		07	1		reserved			
		08	1	01 - 7F	Pan	L63 - C - R63	40	
		09	1		reserved			
		0A	1		reserved			
		0B	1		reserved			
		0C	1		reserved			
		0D	1		reserved			
		0E	1		reserved			
		0F	1		reserved			

TOTAL SIZE = 16 10 (HEX)

2p = Section Number
20 = Piano, 21 = E.Piano, 22 = Sub

Function...	Transmitted	Recognized	Remarks
Basic Channel Default Changed	1 - 16 1 - 16	1 - 16 1 - 16	Memorized
Mode Default Messages Altered	3 X *****	3 X X	Memorized
Note Number : True voice	0 - 127 *****	0 - 127 0 - 127	
Velocity Note ON Note OFF	O 9nH,v=1-127 X 8nH,v=64	O 9nH,v=1-127 O 9nH,v=0 or 8nH	
After Touch Key's Ch's	X X	X X	
Pitch Bend	O	O	
Control Change	0,32 *2 1 O 7,11,67,84 X 64 O *2 66 X *2 12-31 O *1 68,72,73 O *1 75-83,85-93 O *1 102-118 O *1 1-118 O *3	O *2 O O O *2 O *2 O *1 O *1 O *1 O *1 X	Bank Select Sustain Sw Sostenuto
Prog Change : True #	O 0 - 127 *2	O 0 - 7 *2	
System Exclusive	O	O	
Common : Song Pos. : Song Sel. : Tune	X X X	X X X	
System : Clock Real Time : Commands	X X	X X	
Aux : All Sound Off : Reset All Cntrls : Local ON/OFF Mes- : All Notes OFF sages: Active Sense : Reset	X X X X O X	O (120) O (121) X O (123-125) O X	
Notes: *1 receive/transmit if MIDI control mode is on. *2 receive/transmit if switch is on. *3 transmit if assigned to foot controllers.			

Mode 1 : OMNI ON , POLY
 Mode 3 : OMNI OFF, POLY

Mode 2 : OMNI ON ,MONO
 Mode 4 : OMNI OFF,MONO

O : Yes
 X : No

Version 1.60 新機能

このたび、CP88/CP73ではファームウェアのバージョンアップにより、以下の機能が追加されました。
本書では、製品付属の取扱説明書に対して追加または変更となる点についてご説明します。

- 「SETTINGS」に「Mono/Poly」「Portamento」「Pan」を追加しました。これらの機能は、ボイスセクション（「Piano」「E.Piano」「Sub」）ごとに設定できます。また、機能追加に伴い、新規項目「Sound」を設定しました。
- 「Touch Sensitivity」を「Sound」内に移動しました。

新旧ツリー図

・V1.50

Settings

- └ Function
- └ Master Keyboard
- └ Advanced Mode SW
- └ Touch Sensitivity
- └ Controllers
- └ Name

・V1.60

Settings

- └ Sound
 - └ Piano / E.Piano / Sub
 - └ Mono/Poly
 - └ Portamento
 - └ Touch Sensitivity
 - └ Pan
- └ Function
- └ Master Keyboard
- └ Advanced Mode SW
- └ Controllers
- └ Name

Mono/Poly、Portamento の追加

Mono/Poly

[SETTINGS]ボタン → 「Sound」 → 設定対象のボイスセクションを選択 → 「Mono/Poly」

「Mono/Poly」は、ボイスセクション（「Piano」「E. Piano」「Sub」）ごとに設定できます。

「Mono」に設定すると、トップ画面の該当するボイスセクション名（P、E、S）の右側に  アイコンが表示されます。



Portamento

[SETTINGS]ボタン → 「Sound」 → 設定対象のボイスセクションを選択 → 「Portamento」

「Portamento」は、「Mono/Poly」を「Mono」にしているときのみ設定できます。

NOTE

一部のボイス（アコースティックピアノ、エレクトリックピアノなど）には、ポルタメント効果がかかりません。

機能名	内容
Switch	ポルタメント効果をかける（On）か、かけない（Off）かを設定します。 初期設定: Off
Time	ポルタメントのピッチ変化にかかる時間、またはピッチ変化の速さを設定します。 設定値: 0 - 127 初期設定: 64
Mode	鍵盤の弾き方により、どのようにポルタメント効果がかかるかを設定します。 <ul style="list-style-type: none">• Full-time: 常にポルタメントがかかります。• Fingered: レガート演奏（あるキーを押したまま、次のキーを押す演奏）をしたときのみ、ポルタメントの効果がかけられます。 初期設定: Full-time
Time Mode	ピッチが変化する時間的基準を設定します。 <ul style="list-style-type: none">• Rate: 一定の速さでピッチが変化します。• Time: 一定の時間でピッチが変化します。 初期設定: Rate

Pan の追加

[SETTINGS]ボタン → 「Sound」 → 設定対象のボイスセクションを選択 → 「Pan」

「Pan」は、ボイスセクション（「Piano」「E. Piano」「Sub」）ごとに設定できます。

L63～C～R63 の範囲で設定できます。

設定が「C」以外の場合は、スプリットの下にバーが表示されます。

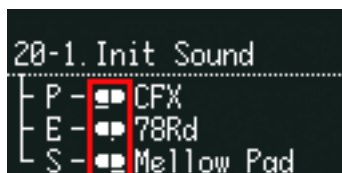

Version 1.50 新機能

このたび、CP88/CP73ではファームウェアのバージョンアップにより、以下の機能が追加されました。
本書では、製品付属の取扱説明書に対して追加または変更となる点についてご説明します。

- 「SETTINGS」に「Touch Sensitivity」項目を追加しました。
- 新規ボイスを追加しました。
- 新規ライブセットサウンドを追加しました。

Touch Sensitivity の追加

[SETTINGS]ボタン → エンコーダーダイヤルでTouch Sensitivityを選択 → 「ENTER」 ボタン

SETTINGSに、Touch Sensitivityを追加しました。

Touch Sensitivityは、ボイスセクションごとの設定が可能です。

Touch Sensitivity

パラメーター名	内容
Piano Depth	<p>選択中のボイスセクションにおいて、「鍵盤を弾いたときのペロシティー」に対する「実際に音源部に送るペロシティー」の変化の割合を設定します。図のように、値を大きくするほどグラフの傾きが急になり、「鍵盤を弾いたときのペロシティー」に対して「実際に音源に送るペロシティー」の変化が大きくなります。</p> <p>値を0に設定すると、「鍵盤を弾いたときのペロシティー」が変化しても「実際に音源に送るペロシティー」は変化しなくなり、オルガンのようにペロシティー変化のない状態になります。</p> <p>設定値: 0 - 127 初期設定: 64</p> <p>オフセット(次項参照)=64の場合</p> <p>実際に音源に送るペロシティー</p> <p>鍵盤を弾いたときのペロシティー</p>

パラメーター名	内容	
Offset	<p>選択中のボイスセクションにおいて、実際に音源に送るペロシティーの値を一律に増減します。図のように、ここでの設定値から 64 を引いて 2 倍した値が実際のペロシティー値にプラス/マイナスされます。ただし、プラス/マイナスした結果、ペロシティーが 1 より小さくなる場合は 1 になり、127 より大きくなる場合は 127 になります。</p> <p>設定値: 0 - 127</p> <p>初期設定: 64</p> <div style="display: flex; justify-content: space-around;"> <div style="text-align: center;"> <p>デプス(前項参照)=64、 オフセット=32 の場合</p> <p>鍵盤を弾いたときのペロシティー</p> </div> <div style="text-align: center;"> <p>デプス(前項参照)=64、 オフセット=96 の場合</p> <p>鍵盤を弾いたときのペロシティー</p> </div> </div> <div style="text-align: center; margin-top: 20px;"> <p>デプス(前項参照)=64、 オフセット=64 の場合</p> <p>鍵盤を弾いたときのペロシティー</p> </div>	
E.Piano	Depth	(Piano の Depth と同様です。)
	Offset	(Piano の Offset と同様です。)
Sub	Depth	(Piano の Depth と同様です。)
	Offset	(Piano の Offset と同様です。)

新ボイスの追加

21個の新規ボイス()を追加しました。

Voice List

Section	Category	No.	Voice	CC No.	
PIANO	Grand Piano	01	CFX	1	
		02	Imperial	2	
		03	S700	3	
		04	Digi Piano	4	
		05	C7	58	
		06	CF3	92	
		07	Nashville C3	95	
		08	Live CF3	96	
		09	Hamburg Grand	107	
	Upright Piano	01	U1	5	
		02	SU7	6	
		03	Felt Piano	108	
	CP	01	CP80 1	7	
		02	CP80 2	8	
	Layered Piano	01	Piano Strings	9	
02		Piano Synth	10		
E.PIANO	Rd	01	78Rd	11	
		02	75Rd Funky	12	
		03	73Rd	13	
		04	67Rd Dark	59	
		05	67Rd Bright	60	
		06	73Rd Studio	93	
		07	74Rd Stage	94	
	Wr	01	Wr Warm	14	
		02	Wr Bright	15	
		03	Wr Wide	61	
	Clv	01	Clavi B	16	
		02	Clavi S	17	
		03	Harpichord	18	
	DX	01	DX Legend	19	
		02	DX Woody	20	
		03	DX FTine	21	
		04	DX 7 II	22	
		05	DX Mellow	23	
		06	DX Crisp	24	
	SUB	Pad/Strings	01	Mellow Pad	25
			02	Spectrum	26
			03	Back Pad	27
			04	Air Choir	28
			05	Natural Str	29
06			Warm Strings	30	
07			OB Strings	31	
08			Section Str	32	
09			Fat Saw Pad	62	
10			Noble Pad	63	
11			Pop Pad	64	
12			Analog Pad	65	
13			Itopia	66	
14			Marcato Str	67	
15			Slow Str	68	
16			Tape Str	69	
17			Oct Syn Str	70	
18			Angel Pad	97	
19			Mystic Pad	98	
20			JP Strings	99	
21			Pop Syn Str	100	
22			Fast Strings	101	
23			Pizzicato	102	
24			Dark Light	109	
25			Digi Pad	110	
26			Lite Strings	111	
27			Unison Str	112	
28			Violin	113	
29			Cello	114	

Section	Category	No.	Voice	CC No.
SUB	Organ	01	Bright Bars	33
		02	Click Organ	34
		03	Draw Organ 1	35
		04	All Bars Out	36
		05	Draw Organ 2	37
		06	60s Combo	38
		07	Compact	39
		08	Panther	40
		09	Pipe Organ 1	41
		10	Pipe Organ 2	42
		11	Accordion	103
	Chromatic Perc.	12	Musette	115
		01	Glocken	43
		02	Vibraphone	44
		03	Xylophone	45
		04	Marimba	46
		05	Brightness	47
		06	Nice Bell	48
		07	Stack Bell	49
		08	Jazz Vibes	71
		09	Marimba 2	72
		10	Kalimba	73
	Others	11	Heaven Bell	74
		01	Syn Lead 1	50
		02	Syn Lead 2	51
		03	Syn Bass	52
		04	E.Bass	53
		05	A.Bass	54
		06	Steel Gt	55
		07	Clean Gt	56
		08	Syn Brass	57
		09	Sine Lead	75
		10	Sync Saw	76
		11	Dirty Hook	77
		12	Classic Mini	78
		13	Funky Mini	79
		14	Nu Mini	80
		15	80s Pop Bass	81
		16	Sub Bass	82
		17	Unison Bass	83
18		Finger Bass	84	
19		Brass	85	
20		Syn Brass 2	86	
21		OB Brass 1	87	
22		OB Brass 2	88	
23		Jazz Flute	89	
24		Tape Flute	90	
25		Harmonica	91	
26		Classic Gt	104	
27		Steel Gt 2	105	
28		Sf. Brass	106	
29	12Strings Gt	116		
30	Clean Gt 2	117		
31	Syn Brass 3	118		
32	Horn	119		
33	Sax Section	120		
34	Soprano Sax	121		
35	Alto Sax	122		
36	Tenor Sax	123		
37	Baritone Sax	124		
38	Soft Square	125		
39	Calliope Lead	126		
40	1o1 Bass	127		

新ライブセットサウンドの追加

新規ボイスを使った新規ライブセットサウンド()が追加されました。

Live Set Sound List

Page	No	Name	Split Point	Section	Voice Name	MSB	LSB	PC
1	1	Natural CFX	G2	Piano	CFX	63	0	1
				E.Piano	-			
				Sub	-			
1	2	NaturalImperial	G2	Piano	Imperial	63	0	2
				E.Piano	-			
				Sub	-			
1	3	Jazz S700	G2	Piano	S700	63	0	3
				E.Piano	-			
				Sub	-			
1	4	Rock Upright	G2	Piano	U1	63	0	4
				E.Piano	-			
				Sub	-			
1	5	Simple 78	G2	Piano	-	63	0	5
				E.Piano	78Rd			
				Sub	-			
1	6	Funky Times	G2	Piano	-	63	0	6
				E.Piano	75Rd Funky			
				Sub	-			
1	7	Tremolo Wr	G2	Piano	-	63	0	7
				E.Piano	Wr Warm			
				Sub	-			
1	8	Clavi B Amped	G2	Piano	-	63	0	8
				E.Piano	Clavi B			
				Sub	-			
2	1	CFX+DX Legend	G2	Piano	CFX	63	1	1
				E.Piano	DX Legend			
				Sub	-			
2	2	A.Bass/78Rd	G2	Piano	U1	63	1	2
				E.Piano	78Rd			
				Sub	A.Bass			
2	3	80s El Grand	G2	Piano	CP80 1	63	1	3
				E.Piano	-			
				Sub	-			
2	4	Brite Pop 8ve	G2	Piano	Digi Piano	63	1	4
				E.Piano	DX Legend			
				Sub	OB Strings			
2	5	E.Bass/78Rd	G2	Piano	-	63	1	5
				E.Piano	78Rd			
				Sub	E.Bass			
2	6	Driven Wr+Pad	G2	Piano	-	63	1	6
				E.Piano	Wr Warm			
				Sub	Warm Strings			
2	7	Imperial + Str	G2	Piano	Imperial	63	1	7
				E.Piano	-			
				Sub	Section Str			
2	8	Ghostly U1	G2	Piano	U1	63	1	8
				E.Piano	Wr Warm			
				Sub	-			
3	1	Rock Grand	G2	Piano	CFX	63	2	1
				E.Piano	-			
				Sub	-			
3	2	S700 + Pad	G2	Piano	S700	63	2	2
				E.Piano	-			
				Sub	OB Strings			
3	3	MonoCmp CFX	G2	Piano	CFX	63	2	3
				E.Piano	-			
				Sub	-			
3	4	Lo Fi Grand	G2	Piano	CFX	63	2	4
				E.Piano	-			
				Sub	-			
3	5	Piano Grind Pad	G2	Piano	Piano Synth	63	2	5
				E.Piano	73Rd			
				Sub	Mellow Pad			
3	6	Lush Love	G2	Piano	Imperial	63	2	6
				E.Piano	78Rd			
				Sub	Brightness			

Page	No	Name	Split Point	Section	Voice Name	MSB	LSB	PC
3	7	Big S700	G2	Piano	S700	63	2	7
				E.Piano	73Rd			
				Sub	OB Strings			
3	8	Piano Scape	G2	Piano	Imperial	63	2	8
				E.Piano	DX Legend			
				Sub	Mellow Pad			
4	1	Compressed CFX	G2	Piano	CFX	63	3	1
				E.Piano	-			
				Sub	-			
4	2	Kinda Squashed	G2	Piano	Imperial	63	3	2
				E.Piano	-			
				Sub	-			
4	3	Layered CFX	G2	Piano	CFX	63	3	3
				E.Piano	75Rd Funky			
				Sub	Mellow Pad			
4	4	Chorus CFX	G2	Piano	CFX	63	3	4
				E.Piano	-			
				Sub	-			
4	5	Upright	G2	Piano	U1	63	3	5
				E.Piano	-			
				Sub	-			
4	6	A Tacky Piano	G2	Piano	SU7	63	3	6
				E.Piano	75Rd Funky			
				Sub	Brightness			
4	7	HonkyTonk Piano	G2	Piano	U1	63	3	7
				E.Piano	-			
				Sub	-			
4	8	Old Record	G2	Piano	U1	63	3	8
				E.Piano	-			
				Sub	-			
5	1	Case 73	G2	Piano	-	63	4	1
				E.Piano	73Rd			
				Sub	-			
5	2	Chimin' Times	G2	Piano	Digi Piano	63	4	2
				E.Piano	78Rd			
				Sub	Glocken			
5	3	Slow Phase	G2	Piano	-	63	4	3
				E.Piano	73Rd			
				Sub	-			
5	4	73 Times OD	G2	Piano	-	63	4	4
				E.Piano	73Rd			
				Sub	-			
5	5	Fast Phaser	G2	Piano	-	63	4	5
				E.Piano	75Rd Funky			
				Sub	-			
5	6	Ampy Funk	G2	Piano	-	63	4	6
				E.Piano	75Rd Funky			
				Sub	-			
5	7	Wet Phase	G2	Piano	-	63	4	7
				E.Piano	78Rd			
				Sub	-			
5	8	78 & Pad	G2	Piano	-	63	4	8
				E.Piano	78Rd			
				Sub	Mellow Pad			
6	1	Wr Bright	G2	Piano	-	63	5	1
				E.Piano	Wr Bright			
				Sub	-			
6	2	Wr Comp	G2	Piano	-	63	5	2
				E.Piano	Wr Warm			
				Sub	-			
6	3	Clavi B	G2	Piano	-	63	5	3
				E.Piano	Clavi B			
				Sub	-			
6	4	Driven S	G2	Piano	-	63	5	4
				E.Piano	Clavi S			
				Sub	-			

Page	No	Name	Split Point	Section	Voice Name	MSB	LSB	PC
6	5	Clavi Wah Dist	G2	Piano	-	63	5	5
				E.Piano	Clavi B			
				Sub	-			
6	6	Squeeze B	G2	Piano	-	63	5	6
				E.Piano	Clavi B			
				Sub	-			
6	7	Long Chorus S	G2	Piano	-	63	5	7
				E.Piano	Clavi S			
				Sub	-			
6	8	Rock Wr w/Ba	G2	Piano	Digi Piano	63	5	8
				E.Piano	Wr Bright			
				Sub	E.Bass			
7	1	CP80 Comp	G2	Piano	CP80 1	63	6	1
				E.Piano	-			
				Sub	-			
7	2	Natural CP80	G2	Piano	CP80 2	63	6	2
				E.Piano	-			
				Sub	-			
7	3	Chorus Legend	G2	Piano	-	63	6	3
				E.Piano	DX Legend			
				Sub	-			
7	4	Chorus FTine	G2	Piano	-	63	6	4
				E.Piano	DX FTine			
				Sub	Mellow Pad			
7	5	Chorus 7II	G2	Piano	-	63	6	5
				E.Piano	DX 7 II			
				Sub	-			
7	6	Legend + Pad	G2	Piano	-	63	6	6
				E.Piano	DX Legend			
				Sub	OB Strings			
7	7	SynBass/DXEP	G2	Piano	-	63	6	7
				E.Piano	DX Mellow			
				Sub	Syn Bass			
7	8	Digi DX Pads	G2	Piano	Digi Piano	63	6	8
				E.Piano	DX Legend			
				Sub	Mellow Pad			
8	1	Bright Bars	G2	Piano	-	63	7	1
				E.Piano	-			
				Sub	Bright Bars			
8	2	All Bars Out	G2	Piano	-	63	7	2
				E.Piano	-			
				Sub	All Bars Out			
8	3	PipeOrgan1	G2	Piano	-	63	7	3
				E.Piano	-			
				Sub	Pipe Organ 1			
8	4	PipeOrgan2	G2	Piano	-	63	7	4
				E.Piano	-			
				Sub	Pipe Organ 2			
8	5	The Red Combo	G2	Piano	-	63	7	5
				E.Piano	-			
				Sub	60s Combo			
8	6	Italian Combo	G2	Piano	-	63	7	6
				E.Piano	-			
				Sub	Compact			
8	7	Aggro Syn Pad	G2	Piano	-	63	7	7
				E.Piano	78Rd			
				Sub	Panther			
8	8	RdBa/60sCombo	G2	Piano	-	63	7	8
				E.Piano	78Rd			
				Sub	60s Combo			
9	1	Strings1	G2	Piano	-	63	8	1
				E.Piano	-			
				Sub	Natural Str			
9	2	Strings2	G2	Piano	-	63	8	2
				E.Piano	-			
				Sub	Section Str			
9	3	Synth Pad1	G2	Piano	-	63	8	3
				E.Piano	-			
				Sub	Mellow Pad			
9	4	Synth Pad2	G2	Piano	-	63	8	4
				E.Piano	-			
				Sub	Warm Strings			
9	5	Vibraphone	G2	Piano	-	63	8	5
				E.Piano	-			
				Sub	Vibraphone			
9	6	Nice Bell	G2	Piano	-	63	8	6
				E.Piano	-			
				Sub	Nice Bell			
9	7	Syn Brass	G2	Piano	-	63	8	7
				E.Piano	-			
				Sub	Syn Brass			

Page	No	Name	Split Point	Section	Voice Name	MSB	LSB	PC
9	8	Syn Lead1	G2	Piano	-	63	8	8
				E.Piano	78Rd			
				Sub	Syn Lead 1			
10	1	Harpichord	G2	Piano	-	63	9	1
				E.Piano	Harpichord			
				Sub	-			
10	2	Electric Harpsi	G2	Piano	-	63	9	2
				E.Piano	Harpichord			
				Sub	-			
10	3	Pipes Rd PBMW	G2	Piano	Digi Piano	63	9	3
				E.Piano	78Rd			
				Sub	Pipe Organ 2			
10	4	Funky w/RdBass	G2	Piano	CP80 1	63	9	4
				E.Piano	78Rd			
				Sub	Marimba			
10	5	Rough Lead	G2	Piano	CP80 2	63	9	5
				E.Piano	78Rd			
				Sub	Back Pad			
10	6	Clavi Syn Wah	G2	Piano	-	63	9	6
				E.Piano	Clavi B			
				Sub	Syn Lead 1			
10	7	Chimin' Crs	G2	Piano	Digi Piano	63	9	7
				E.Piano	75Rd Funky			
				Sub	Glocken			
10	8	Brite Pop	G2	Piano	Digi Piano	63	9	8
				E.Piano	DX Legend			
				Sub	OB Strings			
11	1	Back to 60s SP	G2	Piano	-	63	10	1
				E.Piano	67Rd Dark			
				Sub	-			
11	2	80s Piano JG	G2	Piano	C7	63	10	2
				E.Piano	78Rd			
				Sub	-			
11	3	NaturalWrWideJG	G2	Piano	-	63	10	3
				E.Piano	Wr Wide			
				Sub	-			
11	4	Chorused67Rd SP	G2	Piano	-	63	10	4
				E.Piano	67Rd Bright			
				Sub	-			
11	5	R&B Ballad NS	G2	Piano	-	63	10	5
				E.Piano	67Rd Dark			
				Sub	-			
11	6	Squashed C7 NS	G2	Piano	C7	63	10	6
				E.Piano	-			
				Sub	-			
11	7	WrWideChorus SP	G2	Piano	-	63	10	7
				E.Piano	Wr Wide			
				Sub	-			
11	8	Driven 67Rd JG	G2	Piano	-	63	10	8
				E.Piano	67Rd Bright			
				Sub	-			
12	1	CFX + Slow Str	G2	Piano	CFX	63	11	1
				E.Piano	-			
				Sub	Slow Str			
12	2	C7 + Noble Pad	G2	Piano	C7	63	11	2
				E.Piano	-			
				Sub	Noble Pad			
12	3	78Rd+AnalogPad	G2	Piano	-	63	11	3
				E.Piano	78Rd			
				Sub	Analog Pad			
12	4	78Rd+OBBrass MW	G2	Piano	-	63	11	4
				E.Piano	78Rd			
				Sub	OB Brass 1			
12	5	Sync Saw/DX EP	C3	Piano	-	63	11	5
				E.Piano	DX Legend			
				Sub	Sync Saw			
12	6	Fat Saw Pad MW	G2	Piano	-	63	11	6
				E.Piano	-			
				Sub	Fat Saw Pad			
12	7	OB Brass	G2	Piano	-	63	11	7
				E.Piano	-			
				Sub	OB Brass 2			
12	8	Marcato Str	G2	Piano	-	63	11	8
				E.Piano	-			
				Sub	Marcato Str			
13	1	73Rd Studio	G2	Piano	-	63	12	1
				E.Piano	73Rd Studio			
				Sub	-			
13	2	73Rd Chorus	G2	Piano	-	63	12	2
				E.Piano	73Rd Studio			
				Sub	-			

Page	No	Name	Split Point	Section	Voice Name	MSB	LSB	PC
13	3	73Rd+AnalogPad	G2	Piano	-	63	12	3
				E.Piano	73Rd Studio			
				Sub	Analog Pad			
13	4	73Rd+AP	G2	Piano	C7	63	12	4
				E.Piano	73Rd Studio			
				Sub	-			
13	5	74Rd Stage	G2	Piano	-	63	12	5
				E.Piano	74Rd Stage			
				Sub	-			
13	6	Overdriven 74Rd	G2	Piano	-	63	12	6
				E.Piano	74Rd Stage			
				Sub	-			
13	7	CF3	G2	Piano	CF3	63	12	7
				E.Piano	-			
				Sub	-			
13	8	CF3+AnalogPad	G2	Piano	CF3	63	12	8
				E.Piano	-			
				Sub	Analog Pad			
14	1	Nashville C3	G2	Piano	Nashville C3	63	13	1
				E.Piano	-			
				Sub	-			
14	2	Nville C3 Comp	G2	Piano	Nashville C3	63	13	2
				E.Piano	-			
				Sub	-			
14	3	Fat Jazz Ballad	G2	Piano	Nashville C3	63	13	3
				E.Piano	78Rd			
				Sub	Vibraphone			
14	4	Fundamental Pad	G2	Piano	Nashville C3	63	13	4
				E.Piano	73Rd			
				Sub	Analog Pad			
14	5	Live CF3	G2	Piano	Live CF3	63	13	5
				E.Piano	-			
				Sub	-			
14	6	WestCoast CF3	G2	Piano	Live CF3	63	13	6
				E.Piano	78Rd			
				Sub	Analog Pad			
14	7	Gospel CF3	G2	Piano	Live CF3	63	13	7
				E.Piano	-			
				Sub	-			
14	8	Piano Pad CF3	G2	Piano	Live CF3	63	13	8
				E.Piano	-			
				Sub	Analog Pad			
15	1	Hamburg Grand	G2	Piano	Hamburg Grand	63	14	1
				E.Piano	-			
				Sub	-			
15	2	Ambient Hamburg	G2	Piano	Hamburg Grand	63	14	2
				E.Piano	-			
				Sub	-			
15	3	Soft Ballad H-G	G2	Piano	Hamburg Grand	63	14	3
				E.Piano	78Rd			
				Sub	-			
15	4	Romance Layer	G2	Piano	Hamburg Grand	63	14	4
				E.Piano	-			
				Sub	Slow Str			
15	5	Felt Piano	G2	Piano	Felt Piano	63	14	5
				E.Piano	-			
				Sub	-			
15	6	Night Moods	G2	Piano	Felt Piano	63	14	6
				E.Piano	67Rd Dark			
				Sub	Analog Pad			
15	7	Big MusicBox	G2	Piano	Felt Piano	63	14	7
				E.Piano	DX FTime			
				Sub	E.Bass			
15	8	All Mellow	G2	Piano	Felt Piano	63	14	8
				E.Piano	Wr Wide			
				Sub	Soft Square			

Version 1.40 新機能

このたび、CP88/CP73ではファームウェアのバージョンアップにより、以下の機能が追加されました。
本書では、製品付属の取扱説明書に対して追加または変更となる点についてご説明します。

- 操作性が向上しました。
- 新規ボイスを追加しました。
- 新規ライブセットサウンドを追加しました。

操作性の向上

トップ画面では、ボイスセレクトスイッチの長押しかダブルクリックで、音色リストを表示するようになりました。



NOTE

音色数が5つ以下のカテゴリーでは、音色リストを表示しません。

設定値を表示する画面では、[ENTER] ボタンで確定後、1 つ上の階層画面に戻るようになりました。続けて他のパラメーターを設定できます。[EXIT] ボタンの長押しで、トップ画面に戻るようになりました。

NOTE

MENU画面の階層にいるときは[MENU] ボタンでトップ画面に戻れます。SETTINGS画面の階層にいるときは[SETTINGS] ボタンでトップ画面に戻れます。

新ボイスの追加

12個の新規ボイス()を追加しました。

Voice List

Section	Category	No.	Voice	CC No.	
PIANO	Grand Piano	01	CFX	1	
		02	Imperial	2	
		03	S700	3	
		04	Digi Piano	4	
		05	C7	58	
		06	CF3	92	
		07	Nashville C3	95	
		08	Live CF3	96	
	Upright Piano	01	U1	5	
		02	SU7	6	
	CP	01	CP80 1	7	
		02	CP80 2	8	
	Layered Piano	01	Piano Strings	9	
		02	Piano Synth	10	
E.PIANO	Rd	01	78Rd	11	
		02	75Rd Funky	12	
		03	73Rd	13	
		04	67Rd Dark	59	
		05	67Rd Bright	60	
		06	73Rd Studio	93	
		07	74Rd Stage	94	
	Wr	01	Wr Warm	14	
		02	Wr Bright	15	
		03	Wr Wide	61	
	Clv	01	Clavi B	16	
		02	Clavi S	17	
		03	Harpsichord	18	
	DX	01	DX Legend	19	
		02	DX Woody	20	
		03	DX FTine	21	
		04	DX 7 II	22	
		05	DX Mellow	23	
		06	DX Crisp	24	
	SUB	Pad/Strings	01	Mellow Pad	25
			02	Spectrum	26
			03	Back Pad	27
			04	Air Choir	28
			05	Natural Str	29
06			Warm Strings	30	
07			OB Strings	31	
08			Section Str	32	
09			Fat Saw Pad	62	
10			Noble Pad	63	
11			Pop Pad	64	
12			Analog Pad	65	
13			Itopia	66	
14			Marcato Str	67	
15			Slow Str	68	
16			Tape Str	69	
17			Oct Syn Str	70	
18			Angel Pad	97	
19			Mystic Pad	98	
20			JP Strings	99	
21			Pop Syn Str	100	
22			Fast Strings	101	
23			Pizzicato	102	
Organ		01	Bright Bars	33	
		02	Click Organ	34	
		03	Draw Organ 1	35	
		04	All Bars Out	36	
		05	Draw Organ 2	37	
		06	60s Combo	38	
		07	Compact	39	
		08	Panther	40	
		09	Pipe Organ 1	41	
10		Pipe Organ 2	42		
11	Accordion	103			
Chromatic Perc.	01	Glocken	43		
	02	Vibraphone	44		

Section	Category	No.	Voice	CC No.	
SUB		03	Xylophone	45	
		04	Marimba	46	
		05	Brightness	47	
		06	Jazz Vibes	71	
		07	Marimba 2	72	
		08	Kalimba	73	
		09	Heaven Bell	74	
		10	Nice Bell	48	
		11	Stack Bell	49	
		Others	01	Syn Lead 1	50
			02	Syn Lead 2	51
	03		Syn Bass	52	
	04		E.Bass	53	
	05		A.Bass	54	
	06		Steel Gt	55	
	07		Clean Gt	56	
	08		Syn Brass	57	
	09		Sine Lead	75	
	10		Sync Saw	76	
	11		Dirty Hook	77	
	12		Classic Mini	78	
	13		Funky Mini	79	
	14		Nu Mini	80	
	15		80s Pop Bass	81	
	16		Sub Bass	82	
	17		Unison Bass	83	
	18	Finger Bass	84		
	19	Brass	85		
20	Syn Brass 2	86			
21	OB Brass 1	87			
22	OB Brass 2	88			
23	Jazz Flute	89			
24	Tape Flute	90			
25	Harmonica	91			
26	Classic Gt	104			
27	Steel Gt 2	105			
28	Sf. Brass	106			

新ライブセットサウンドの追加

新規ボイスを使った新規ライブセットサウンド()が追加されました。

Live Set Sound List

Page	No	Name	Split Point	Section	Voice Name	MSB	LSB	PC
1	1	Natural CFX	G2	Piano	CFX	63	0	1
				E.Piano	-			
				Sub	-			
1	2	NaturalImperial	G2	Piano	Imperial	63	0	2
				E.Piano	-			
				Sub	-			
1	3	Jazz S700	G2	Piano	S700	63	0	3
				E.Piano	-			
				Sub	-			
1	4	Rock Upright	G2	Piano	U1	63	0	4
				E.Piano	-			
				Sub	-			
1	5	Simple 78	G2	Piano	-	63	0	5
				E.Piano	78Rd			
				Sub	-			
1	6	Funky Times	G2	Piano	-	63	0	6
				E.Piano	75Rd Funky			
				Sub	-			
1	7	Tremolo Wr	G2	Piano	-	63	0	7
				E.Piano	Wr Warm			
				Sub	-			
1	8	Clavi B Amped	G2	Piano	-	63	0	8
				E.Piano	Clavi B			
				Sub	-			
2	1	CFX+DX Legend	G2	Piano	CFX	63	1	1
				E.Piano	DX Legend			
				Sub	-			
2	2	A.Bass/78Rd	G2	Piano	U1	63	1	2
				E.Piano	78Rd			
				Sub	A.Bass			
2	3	80s El Grand	G2	Piano	CP80 1	63	1	3
				E.Piano	-			
				Sub	-			
2	4	Brite Pop 8ve	G2	Piano	Digi Piano	63	1	4
				E.Piano	DX Legend			
				Sub	OB Strings			
2	5	E.Bass/78Rd	G2	Piano	-	63	1	5
				E.Piano	78Rd			
				Sub	E.Bass			
2	6	Driven Wr+Pad	G2	Piano	-	63	1	6
				E.Piano	Wr Warm			
				Sub	Warm Strings			
2	7	Imperial + Str	G2	Piano	Imperial	63	1	7
				E.Piano	-			
				Sub	Section Str			
2	8	Ghostly U1	G2	Piano	U1	63	1	8
				E.Piano	Wr Warm			
				Sub	-			
3	1	Rock Grand	G2	Piano	CFX	63	2	1
				E.Piano	-			
				Sub	-			
3	2	S700 + Pad	G2	Piano	S700	63	2	2
				E.Piano	-			
				Sub	OB Strings			
3	3	MonoCmp CFX	G2	Piano	CFX	63	2	3
				E.Piano	-			
				Sub	-			
3	4	Lo Fi Grand	G2	Piano	CFX	63	2	4
				E.Piano	-			
				Sub	-			
3	5	Piano Grind Pad	G2	Piano	Piano Synth	63	2	5
				E.Piano	73Rd			
				Sub	Mellow Pad			
3	6	Lush Love	G2	Piano	Imperial	63	2	6
				E.Piano	78Rd			
				Sub	Brightness			

Page	No	Name	Split Point	Section	Voice Name	MSB	LSB	PC
3	7	Big S700	G2	Piano	S700	63	2	7
				E.Piano	73Rd			
				Sub	OB Strings			
3	8	Piano Scape	G2	Piano	Imperial	63	2	8
				E.Piano	DX Legend			
				Sub	Mellow Pad			
4	1	Compressed CFX	G2	Piano	CFX	63	3	1
				E.Piano	-			
				Sub	-			
4	2	Kinda Squashed	G2	Piano	Imperial	63	3	2
				E.Piano	-			
				Sub	-			
4	3	Layered CFX	G2	Piano	CFX	63	3	3
				E.Piano	75Rd Funky			
				Sub	Mellow Pad			
4	4	Chorus CFX	G2	Piano	CFX	63	3	4
				E.Piano	-			
				Sub	-			
4	5	Upright	G2	Piano	U1	63	3	5
				E.Piano	-			
				Sub	-			
4	6	A Tacky Piano	G2	Piano	SU7	63	3	6
				E.Piano	75Rd Funky			
				Sub	Brightness			
4	7	HonkyTonk Piano	G2	Piano	U1	63	3	7
				E.Piano	-			
				Sub	-			
4	8	Old Record	G2	Piano	U1	63	3	8
				E.Piano	-			
				Sub	-			
5	1	Case 73	G2	Piano	-	63	4	1
				E.Piano	73Rd			
				Sub	-			
5	2	Chimin' Times	G2	Piano	Digi Piano	63	4	2
				E.Piano	78Rd			
				Sub	Glocken			
5	3	Slow Phase	G2	Piano	-	63	4	3
				E.Piano	73Rd			
				Sub	-			
5	4	73 Times OD	G2	Piano	-	63	4	4
				E.Piano	73Rd			
				Sub	-			
5	5	Fast Phaser	G2	Piano	-	63	4	5
				E.Piano	75Rd Funky			
				Sub	-			
5	6	Ampy Funk	G2	Piano	-	63	4	6
				E.Piano	75Rd Funky			
				Sub	-			
5	7	Wet Phase	G2	Piano	-	63	4	7
				E.Piano	78Rd			
				Sub	-			
5	8	78 & Pad	G2	Piano	-	63	4	8
				E.Piano	78Rd			
				Sub	Mellow Pad			
6	1	Wr Bright	G2	Piano	-	63	5	1
				E.Piano	Wr Bright			
				Sub	-			
6	2	Wr Comp	G2	Piano	-	63	5	2
				E.Piano	Wr Warm			
				Sub	-			
6	3	Clavi B	G2	Piano	-	63	5	3
				E.Piano	Clavi B			
				Sub	-			
6	4	Driven S	G2	Piano	-	63	5	4
				E.Piano	Clavi S			
				Sub	-			

Page	No	Name	Split Point	Section	Voice Name	MSB	LSB	PC
6	5	Clavi Wah Dist	G2	Piano	-	63	5	5
				E.Piano	Clavi B			
				Sub	-			
6	6	Squeeze B	G2	Piano	-	63	5	6
				E.Piano	Clavi B			
				Sub	-			
6	7	Long Chorus S	G2	Piano	-	63	5	7
				E.Piano	Clavi S			
				Sub	-			
6	8	Rock Wr w/Ba	G2	Piano	Digi Piano	63	5	8
				E.Piano	Wr Bright			
				Sub	E.Bass			
7	1	CP80 Comp	G2	Piano	CP80 1	63	6	1
				E.Piano	-			
				Sub	-			
7	2	Natural CP80	G2	Piano	CP80 2	63	6	2
				E.Piano	-			
				Sub	-			
7	3	Chorus Legend	G2	Piano	-	63	6	3
				E.Piano	DX Legend			
				Sub	-			
7	4	Chorus FTine	G2	Piano	-	63	6	4
				E.Piano	DX FTine			
				Sub	Mellow Pad			
7	5	Chorus 7II	G2	Piano	-	63	6	5
				E.Piano	DX 7 II			
				Sub	-			
7	6	Legend + Pad	G2	Piano	-	63	6	6
				E.Piano	DX Legend			
				Sub	OB Strings			
7	7	SynBass/DXEP	G2	Piano	-	63	6	7
				E.Piano	DX Mellow			
				Sub	Syn Bass			
7	8	Digi DX Pads	G2	Piano	Digi Piano	63	6	8
				E.Piano	DX Legend			
				Sub	Mellow Pad			
8	1	Bright Bars	G2	Piano	-	63	7	1
				E.Piano	-			
				Sub	Bright Bars			
8	2	All Bars Out	G2	Piano	-	63	7	2
				E.Piano	-			
				Sub	All Bars Out			
8	3	PipeOrgan1	G2	Piano	-	63	7	3
				E.Piano	-			
				Sub	Pipe Organ 1			
8	4	PipeOrgan2	G2	Piano	-	63	7	4
				E.Piano	-			
				Sub	Pipe Organ 2			
8	5	The Red Combo	G2	Piano	-	63	7	5
				E.Piano	-			
				Sub	60s Combo			
8	6	Italian Combo	G2	Piano	-	63	7	6
				E.Piano	-			
				Sub	Compact			
8	7	Aggro Syn Pad	G2	Piano	-	63	7	7
				E.Piano	78Rd			
				Sub	Panther			
8	8	RdBa/60sCombo	G2	Piano	-	63	7	8
				E.Piano	78Rd			
				Sub	60s Combo			
9	1	Strings1	G2	Piano	-	63	8	1
				E.Piano	-			
				Sub	Natural Str			
9	2	Strings2	G2	Piano	-	63	8	2
				E.Piano	-			
				Sub	Section Str			
9	3	Synth Pad1	G2	Piano	-	63	8	3
				E.Piano	-			
				Sub	Mellow Pad			
9	4	Synth Pad2	G2	Piano	-	63	8	4
				E.Piano	-			
				Sub	Warm Strings			
9	5	Vibraphone	G2	Piano	-	63	8	5
				E.Piano	-			
				Sub	Vibraphone			
9	6	Nice Bell	G2	Piano	-	63	8	6
				E.Piano	-			
				Sub	Nice Bell			

Page	No	Name	Split Point	Section	Voice Name	MSB	LSB	PC
9	7	Syn Brass	G2	Piano	-	63	8	7
				E.Piano	-			
				Sub	Syn Brass			
9	8	Syn Lead1	G2	Piano	-	63	8	8
				E.Piano	78Rd			
				Sub	Syn Lead 1			
10	1	Harpischord	G2	Piano	-	63	9	1
				E.Piano	Harpischord			
				Sub	-			
10	2	Electric Harpsi	G2	Piano	-	63	9	2
				E.Piano	Harpischord			
				Sub	-			
10	3	Pipes Rd PBMW	G2	Piano	Digi Piano	63	9	3
				E.Piano	78Rd			
				Sub	Pipe Organ 2			
10	4	Funky w/RdBass	G2	Piano	CP80 1	63	9	4
				E.Piano	78Rd			
				Sub	Marimba			
10	5	Rough Lead	G2	Piano	CP80 2	63	9	5
				E.Piano	78Rd			
				Sub	Back Pad			
10	6	Clavi Syn Wah	G2	Piano	-	63	9	6
				E.Piano	Clavi B			
				Sub	Syn Lead 1			
10	7	Chimin' Crs	G2	Piano	Digi Piano	63	9	7
				E.Piano	75Rd Funky			
				Sub	Glocken			
10	8	Brite Pop	G2	Piano	Digi Piano	63	9	8
				E.Piano	DX Legend			
				Sub	OB Strings			
11	1	Back to 60s SP	G2	Piano	-	63	10	1
				E.Piano	67Rd Dark			
				Sub	-			
11	2	80s Piano JG	G2	Piano	C7	63	10	2
				E.Piano	78Rd			
				Sub	-			
11	3	NaturalWrWideJG	G2	Piano	-	63	10	3
				E.Piano	Wr Wide			
				Sub	-			
11	4	Chorused67Rd SP	G2	Piano	-	63	10	4
				E.Piano	67Rd Bright			
				Sub	-			
11	5	R&B Ballad NS	G2	Piano	-	63	10	5
				E.Piano	67Rd Dark			
				Sub	-			
11	6	Squashed C7 NS	G2	Piano	C7	63	10	6
				E.Piano	-			
				Sub	-			
11	7	WrWideChorus SP	G2	Piano	-	63	10	7
				E.Piano	Wr Wide			
				Sub	-			
11	8	Driven 67Rd JG	G2	Piano	-	63	10	8
				E.Piano	67Rd Bright			
				Sub	-			
12	1	CFX + Slow Str	G2	Piano	CFX	63	11	1
				E.Piano	-			
				Sub	Slow Str			
12	2	C7 + Noble Pad	G2	Piano	C7	63	11	2
				E.Piano	-			
				Sub	Noble Pad			
12	3	78Rd+AnalogPad	G2	Piano	-	63	11	3
				E.Piano	78Rd			
				Sub	Analog Pad			
12	4	78Rd+OBBrass MW	G2	Piano	-	63	11	4
				E.Piano	78Rd			
				Sub	OB Brass 1			
12	5	Sync Saw/DX EP	C3	Piano	-	63	11	5
				E.Piano	DX Legend			
				Sub	Sync Saw			
12	6	Fat Saw Pad MW	G2	Piano	-	63	11	6
				E.Piano	-			
				Sub	Fat Saw Pad			
12	7	OB Brass	G2	Piano	-	63	11	7
				E.Piano	-			
				Sub	OB Brass 2			
12	8	Marcato Str	G2	Piano	-	63	11	8
				E.Piano	-			
				Sub	Marcato Str			

Page	No	Name	Split Point	Section	Voice Name	MSB	LSB	PC
13	1	73Rd Studio	G2	Piano	-	63	12	1
				E.Piano	73Rd Studio			
				Sub	-			
13	2	73Rd Chorus	G2	Piano	-	63	12	2
				E.Piano	73Rd Studio			
				Sub	-			
13	3	73Rd+AnalogPad	G2	Piano	-	63	12	3
				E.Piano	73Rd Studio			
				Sub	Analog Pad			
13	4	73Rd+AP	G2	Piano	C7	63	12	4
				E.Piano	73Rd Studio			
				Sub	-			
13	5	74Rd Stage	G2	Piano	-	63	12	5
				E.Piano	74Rd Stage			
				Sub	-			
13	6	Overdriven 74Rd	G2	Piano	-	63	12	6
				E.Piano	74Rd Stage			
				Sub	-			
13	7	CF3	G2	Piano	CF3	63	12	7
				E.Piano	-			
				Sub	-			
13	8	CF3+AnalogPad	G2	Piano	CF3	63	12	8
				E.Piano	-			
				Sub	Analog Pad			
14	1	Nashville C3	G2	Piano	Nashville C3	63	13	1
				E.Piano	-			
				Sub	-			
14	2	Nville C3 Comp	G2	Piano	Nashville C3	63	13	2
				E.Piano	-			
				Sub	-			
14	3	Fat Jazz Ballad	G2	Piano	Nashville C3	63	13	3
				E.Piano	78Rd			
				Sub	Vibraphone			
14	4	Fundamental Pad	G2	Piano	Nashville C3	63	13	4
				E.Piano	73Rd			
				Sub	Analog Pad			
14	5	Live CF3	G2	Piano	Live CF3	63	13	5
				E.Piano	-			
				Sub	-			
14	6	WestCoast CF3	G2	Piano	Live CF3	63	13	6
				E.Piano	78Rd			
				Sub	Analog Pad			
14	7	Gospel CF3	G2	Piano	Live CF3	63	13	7
				E.Piano	-			
				Sub	-			
14	8	Piano Pad CF3	G2	Piano	Live CF3	63	13	8
				E.Piano	-			
				Sub	Analog Pad			

Version 1.30 新機能

このたび、CP88/CP73ではファームウェアのバージョンアップにより、以下の機能が追加されました。
本書では、製品付属の取扱説明書に対して追加または変更となる点についてご説明します。

- マスター EQの設定をライブセットサウンドに保存できるようになりました。
- 操作性が向上しました。
- 新規ボイスを追加しました。
- 新規ライブセットサウンドを追加しました。

マスターEQの設定をライブセットサウンドに保存する

[SETTINGS]ボタン → エンコーダーダイヤルでFunctionを選択 → 「ENTER」ボタン

Function に、Live Set EQ を追加しました。

Function

機能名		内容
Live Set EQ	Mode SW	マスターEQの設定をライブセットサウンドに保存するかどうかを設定します。Onに設定するとEQ（アイコン）がトップ画面に表示されます。 
EQ Settings		保存されたマスターEQの設定値をEQ Settingsで確認できます。また、ノブやボタンによる操作だけでなくEQ Settingsを使ったEQ設定もできます。
High Gain		High Gain 高音域(5 kHz)のゲインを設定します。 設定値：-12 dB - +12 dB
Mid Gain		Mid Gain 中音域(100~10 kHz)のゲインを設定します。 設定値：-12 dB - +12 dB
Mid Frequency		Mid Frequency 中音域の中心周波数を設定します。 設定値：100 - 10 kHz
Low Gain		Low Gain 低音域(80 Hz)のゲインを設定します。 設定値：-12 dB - +12 dB
ON/OFF		マスターEQ をかける(オン)か、かけない(オフ)かを切り替えます。

操作性の向上

設定値が表示される画面では、設定開始時の値を表示するようになりました。



Name画面で[ENTER]を押して確定したときに、ストアするかどうかを確認する画面が出るようになりました。「Store」を選ぶとStore画面に移動し、「Do not store now」を選ぶとライブセット名のみ設定して、Home画面に戻ります。

NOTE

「Do not store now」を選ぶと、ストアしない限りライブセット名は保存されません。ご注意ください。

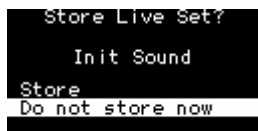

[EXIT]+[TOUCH]でFixed Velocity画面に移動できるようになりました。

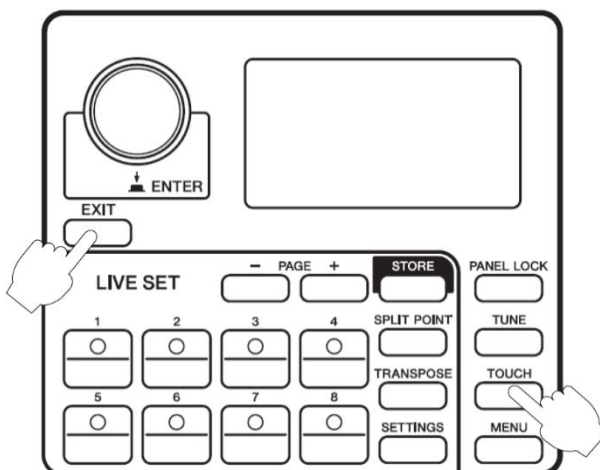

[SPLIT]+鍵盤で、スプリットポイントを設定して自動的に画面を閉じることができるようになりました。

新ボイスの追加

3個の新規ボイス()を追加しました。

Voice List

Section	Category	No.	Voice	CC No.	
PIANO	Grand Piano	01	CFX	1	
		02	Imperial	2	
		03	S700	3	
		04	Digi Piano	4	
		05	C7	58	
		06	CF3	92	
	Upright Piano	01	U1	5	
		02	SU7	6	
	CP	01	CP80 1	7	
		02	CP80 2	8	
	Layered Piano	01	Piano Strings	9	
		02	Piano Synth	10	
	E.PIANO	Rd	01	78Rd	11
			02	75Rd Funky	12
03			73Rd	13	
04			67Rd Dark	59	
05			67Rd Bright	60	
06			73Rd Studio	93	
07			74Rd Stage	94	
Wr		01	Wr Warm	14	
		02	Wr Bright	15	
		03	Wr Wide	61	
Clv	01	Clavi B	16		
	02	Clavi S	17		
	03	Harpichord	18		
DX	01	DX Legend	19		
	02	DX Woody	20		
	03	DX FTine	21		
	04	DX 7 II	22		
	05	DX Mellow	23		
	06	DX Crisp	24		
SUB	Pad/Strings	01	Mellow Pad	25	
		02	Spectrum	26	
		03	Back Pad	27	
		04	Air Choir	28	
		05	Natural Str	29	
		06	Warm Strings	30	
		07	OB Strings	31	
		08	Section Str	32	
		09	Fat Saw Pad	62	
		10	Noble Pad	63	
		11	Pop Pad	64	
		12	Analog Pad	65	
		13	Itopia	66	
		14	Marcato Str	67	
		15	Slow Str	68	
		16	Tape Str	69	
		17	Oct Syn Str	70	
	Organ	01	Bright Bars	33	
		02	Click Organ	34	
		03	Draw Organ 1	35	
		04	All Bars Out	36	
		05	Draw Organ 2	37	
		06	60s Combo	38	
		07	Compact	39	
		08	Panther	40	
		09	Pipe Organ 1	41	
		10	Pipe Organ 2	42	
	Chromatic Perc.	01	Glocken	43	
		02	Vibraphone	44	
		03	Xylophone	45	
		04	Marimba	46	
		05	Brightness	47	
		06	Jazz Vibes	71	
		07	Marimba 2	72	
		08	Kalimba	73	
		09	Heaven Bell	74	
		10	Nice Bell	48	
		11	Stack Bell	49	

Section	Category	No.	Voice	CC No.
SUB	Others	01	Syn Lead 1	50
		02	Syn Lead 2	51
		03	Syn Bass	52
		04	E.Bass	53
		05	A.Bass	54
		06	Steel Gt	55
		07	Clean Gt	56
		08	Syn Brass	57
		09	Sine Lead	75
		10	Sync Saw	76
		11	Dirty Hook	77
		12	Classic Mini	78
		13	Funky Mini	79
		14	Nu Mini	80
		15	80s Pop Bass	81
		16	Sub Bass	82
		17	Unison Bass	83
		18	Finger Bass	84
		19	Brass	85
		20	Syn Brass 2	86
		21	OB Brass 1	87
		22	OB Brass 2	88
		23	Jazz Flute	89
		24	Tape Flute	90
		25	Harmonica	91

新ライブセットサウンドの追加

新規ボイスを使った新規ライブセットサウンド()が追加されました。

Live Set Sound List

Page	No	Name	Split Point	Section	Voice Name	MSB	LSB	PC
1	1	Natural CFX	G2	Piano	CFX	63	0	1
				E.Piano	-			
				Sub	-			
1	2	NaturalImperial	G2	Piano	Imperial	63	0	2
				E.Piano	-			
				Sub	-			
1	3	Jazz S700	G2	Piano	S700	63	0	3
				E.Piano	-			
				Sub	-			
1	4	Rock Upright	G2	Piano	U1	63	0	4
				E.Piano	-			
				Sub	-			
1	5	Simple 78	G2	Piano	-	63	0	5
				E.Piano	78Rd			
				Sub	-			
1	6	Funky Tines	G2	Piano	-	63	0	6
				E.Piano	75Rd Funky			
				Sub	-			
1	7	Tremolo Wr	G2	Piano	-	63	0	7
				E.Piano	Wr Warm			
				Sub	-			
1	8	Clavi B Amped	G2	Piano	-	63	0	8
				E.Piano	Clavi B			
				Sub	-			
2	1	CFX+DX Legend	G2	Piano	CFX	63	1	1
				E.Piano	DX Legend			
				Sub	-			
2	2	A.Bass/78Rd	G2	Piano	U1	63	1	2
				E.Piano	78Rd			
				Sub	A.Bass			
2	3	80s El Grand	G2	Piano	CP80 1	63	1	3
				E.Piano	-			
				Sub	-			
2	4	Brite Pop 8ve	G2	Piano	Digi Piano	63	1	4
				E.Piano	DX Legend			
				Sub	OB Strings			
2	5	E.Bass/78Rd	G2	Piano	-	63	1	5
				E.Piano	78Rd			
				Sub	E.Bass			
2	6	Driven Wr+Pad	G2	Piano	-	63	1	6
				E.Piano	Wr Warm			
				Sub	Warm Strings			
2	7	Imperial + Str	G2	Piano	Imperial	63	1	7
				E.Piano	-			
				Sub	Section Str			
2	8	Ghostly U1	G2	Piano	U1	63	1	8
				E.Piano	Wr Warm			
				Sub	-			
3	1	Rock Grand	G2	Piano	CFX	63	2	1
				E.Piano	-			
				Sub	-			
3	2	S700 + Pad	G2	Piano	S700	63	2	2
				E.Piano	-			
				Sub	OB Strings			
3	3	MonoCmp CFX	G2	Piano	CFX	63	2	3
				E.Piano	-			
				Sub	-			
3	4	Lo Fi Grand	G2	Piano	CFX	63	2	4
				E.Piano	-			
				Sub	-			
3	5	Piano Grind Pad	G2	Piano	Piano Synth	63	2	5
				E.Piano	73Rd			
				Sub	Mellow Pad			
3	6	Lush Love	G2	Piano	Imperial	63	2	6
				E.Piano	78Rd			
				Sub	Brightness			

Page	No	Name	Split Point	Section	Voice Name	MSB	LSB	PC
3	7	Big S700	G2	Piano	S700	63	2	7
				E.Piano	73Rd			
				Sub	OB Strings			
3	8	Piano Scape	G2	Piano	Imperial	63	2	8
				E.Piano	DX Legend			
				Sub	Mellow Pad			
4	1	Compressed CFX	G2	Piano	CFX	63	3	1
				E.Piano	-			
				Sub	-			
4	2	Kinda Squashed	G2	Piano	Imperial	63	3	2
				E.Piano	-			
				Sub	-			
4	3	Layered CFX	G2	Piano	CFX	63	3	3
				E.Piano	75Rd Funky			
				Sub	Mellow Pad			
4	4	Chorus CFX	G2	Piano	CFX	63	3	4
				E.Piano	-			
				Sub	-			
4	5	Upright	G2	Piano	U1	63	3	5
				E.Piano	-			
				Sub	-			
4	6	A Tacky Piano	G2	Piano	SU7	63	3	6
				E.Piano	75Rd Funky			
				Sub	Brightness			
4	7	HonkyTonk Piano	G2	Piano	U1	63	3	7
				E.Piano	-			
				Sub	-			
4	8	Old Record	G2	Piano	U1	63	3	8
				E.Piano	-			
				Sub	-			
5	1	Case 73	G2	Piano	-	63	4	1
				E.Piano	73Rd			
				Sub	-			
5	2	Chimin' Tines	G2	Piano	Digi Piano	63	4	2
				E.Piano	78Rd			
				Sub	Glocken			
5	3	Slow Phase	G2	Piano	-	63	4	3
				E.Piano	73Rd			
				Sub	-			
5	4	73 Tines OD	G2	Piano	-	63	4	4
				E.Piano	73Rd			
				Sub	-			
5	5	Fast Phaser	G2	Piano	-	63	4	5
				E.Piano	75Rd Funky			
				Sub	-			
5	6	Ampy Funk	G2	Piano	-	63	4	6
				E.Piano	75Rd Funky			
				Sub	-			
5	7	Wet Phase	G2	Piano	-	63	4	7
				E.Piano	78Rd			
				Sub	-			
5	8	78 & Pad	G2	Piano	-	63	4	8
				E.Piano	78Rd			
				Sub	Mellow Pad			
6	1	Wr Bright	G2	Piano	-	63	5	1
				E.Piano	Wr Bright			
				Sub	-			
6	2	Wr Comp	G2	Piano	-	63	5	2
				E.Piano	Wr Warm			
				Sub	-			
6	3	Clavi B	G2	Piano	-	63	5	3
				E.Piano	Clavi B			
				Sub	-			
6	4	Driven S	G2	Piano	-	63	5	4
				E.Piano	Clavi S			
				Sub	-			

Page	No	Name	Split Point	Section	Voice Name	MSB	LSB	PC
6	5	Clavi Wah Dist	G2	Piano	-	63	5	5
				E.Piano	Clavi B			
				Sub	-			
6	6	Squeeze B	G2	Piano	-	63	5	6
				E.Piano	Clavi B			
				Sub	-			
6	7	Long Chorus S	G2	Piano	-	63	5	7
				E.Piano	Clavi S			
				Sub	-			
6	8	Rock Wr w/Ba	G2	Piano	Digi Piano	63	5	8
				E.Piano	Wr Bright			
				Sub	E.Bass			
7	1	CP80 Comp	G2	Piano	CP80 1	63	6	1
				E.Piano	-			
				Sub	-			
7	2	Natural CP80	G2	Piano	CP80 2	63	6	2
				E.Piano	-			
				Sub	-			
7	3	Chorus Legend	G2	Piano	-	63	6	3
				E.Piano	DX Legend			
				Sub	-			
7	4	Chorus FTine	G2	Piano	-	63	6	4
				E.Piano	DX FTine			
				Sub	Mellow Pad			
7	5	Chorus 7II	G2	Piano	-	63	6	5
				E.Piano	DX 7 II			
				Sub	-			
7	6	Legend + Pad	G2	Piano	-	63	6	6
				E.Piano	DX Legend			
				Sub	OB Strings			
7	7	SynBass/DXEP	G2	Piano	-	63	6	7
				E.Piano	DX Mellow			
				Sub	Syn Bass			
7	8	Digi DX Pads	G2	Piano	Digi Piano	63	6	8
				E.Piano	DX Legend			
				Sub	Mellow Pad			
8	1	Bright Bars	G2	Piano	-	63	7	1
				E.Piano	-			
				Sub	Bright Bars			
8	2	All Bars Out	G2	Piano	-	63	7	2
				E.Piano	-			
				Sub	All Bars Out			
8	3	PipeOrgan1	G2	Piano	-	63	7	3
				E.Piano	-			
				Sub	Pipe Organ 1			
8	4	PipeOrgan2	G2	Piano	-	63	7	4
				E.Piano	-			
				Sub	Pipe Organ 2			
8	5	The Red Combo	G2	Piano	-	63	7	5
				E.Piano	-			
				Sub	60s Combo			
8	6	Italian Combo	G2	Piano	-	63	7	6
				E.Piano	-			
				Sub	Compact			
8	7	Aggro Syn Pad	G2	Piano	-	63	7	7
				E.Piano	78Rd			
				Sub	Panther			
8	8	RdBa/60sCombo	G2	Piano	-	63	7	8
				E.Piano	78Rd			
				Sub	60s Combo			
9	1	Strings1	G2	Piano	-	63	8	1
				E.Piano	-			
				Sub	Natural Str			
9	2	Strings2	G2	Piano	-	63	8	2
				E.Piano	-			
				Sub	Section Str			
9	3	Synth Pad1	G2	Piano	-	63	8	3
				E.Piano	-			
				Sub	Mellow Pad			
9	4	Synth Pad2	G2	Piano	-	63	8	4
				E.Piano	-			
				Sub	Warm Strings			
9	5	Vibraphone	G2	Piano	-	63	8	5
				E.Piano	-			
				Sub	Vibraphone			
9	6	Nice Bell	G2	Piano	-	63	8	6
				E.Piano	-			
				Sub	Nice Bell			

Page	No	Name	Split Point	Section	Voice Name	MSB	LSB	PC
9	7	Syn Brass	G2	Piano	-	63	8	7
				E.Piano	-			
				Sub	Syn Brass			
9	8	Syn Lead1	G2	Piano	-	63	8	8
				E.Piano	78Rd			
				Sub	Syn Lead 1			
10	1	Harpischord	G2	Piano	-	63	9	1
				E.Piano	Harpischord			
				Sub	-			
10	2	Electric Harpsi	G2	Piano	-	63	9	2
				E.Piano	Harpischord			
				Sub	-			
10	3	Pipes Rd PBMW	G2	Piano	Digi Piano	63	9	3
				E.Piano	78Rd			
				Sub	Pipe Organ 2			
10	4	Funky w/RdBass	G2	Piano	CP80 1	63	9	4
				E.Piano	78Rd			
				Sub	Marimba			
10	5	Rough Lead	G2	Piano	CP80 2	63	9	5
				E.Piano	78Rd			
				Sub	Back Pad			
10	6	Clavi Syn Wah	G2	Piano	-	63	9	6
				E.Piano	Clavi B			
				Sub	Syn Lead 1			
10	7	Chimin' Crs	G2	Piano	Digi Piano	63	9	7
				E.Piano	75Rd Funky			
				Sub	Glocken			
10	8	Brite Pop	G2	Piano	Digi Piano	63	9	8
				E.Piano	DX Legend			
				Sub	OB Strings			
11	1	Back to 60s SP	G2	Piano	-	63	10	1
				E.Piano	67Rd Dark			
				Sub	-			
11	2	80s Piano JG	G2	Piano	C7	63	10	2
				E.Piano	78Rd			
				Sub	-			
11	3	NaturalWrWideJG	G2	Piano	-	63	10	3
				E.Piano	Wr Wide			
				Sub	-			
11	4	Chorused67Rd SP	G2	Piano	-	63	10	4
				E.Piano	67Rd Bright			
				Sub	-			
11	5	R&B Ballad NS	G2	Piano	-	63	10	5
				E.Piano	67Rd Dark			
				Sub	-			
11	6	Squashed C7 NS	G2	Piano	C7	63	10	6
				E.Piano	-			
				Sub	-			
11	7	WrWideChorus SP	G2	Piano	-	63	10	7
				E.Piano	Wr Wide			
				Sub	-			
11	8	Driven 67Rd JG	G2	Piano	-	63	10	8
				E.Piano	67Rd Bright			
				Sub	-			
12	1	CFX + Slow Str	G2	Piano	CFX	63	11	1
				E.Piano	-			
				Sub	Slow Str			
12	2	C7 + Noble Pad	G2	Piano	C7	63	11	2
				E.Piano	-			
				Sub	Noble Pad			
12	3	78Rd+AnalogPad	G2	Piano	-	63	11	3
				E.Piano	78Rd			
				Sub	Analog Pad			
12	4	78Rd+OBBrass MW	G2	Piano	-	63	11	4
				E.Piano	78Rd			
				Sub	OB Brass 1			
12	5	Sync Saw/DX EP	C3	Piano	-	63	11	5
				E.Piano	DX Legend			
				Sub	Sync Saw			
12	6	Fat Saw Pad MW	G2	Piano	-	63	11	6
				E.Piano	-			
				Sub	Fat Saw Pad			
12	7	OB Brass	G2	Piano	-	63	11	7
				E.Piano	-			
				Sub	OB Brass 2			
12	8	Marcato Str	G2	Piano	-	63	11	8
				E.Piano	-			
				Sub	Marcato Str			

Page	No	Name	Split Point	Section	Voice Name	MSB	LSB	PC
13	1	73Rd Studio	G2	Piano	-	63	12	1
				E.Piano	73Rd Studio			
				Sub	-			
13	2	73Rd Chorus	G2	Piano	-	63	12	2
				E.Piano	73Rd Studio			
				Sub	-			
13	3	73Rd+AnalogPad	G2	Piano	-	63	12	3
				E.Piano	73Rd Studio			
				Sub	Analog Pad			
13	4	73Rd+AP	G2	Piano	C7	63	12	4
				E.Piano	73Rd Studio			
				Sub	-			
13	5	74Rd Stage	G2	Piano	-	63	12	5
				E.Piano	74Rd Stage			
				Sub	-			
13	6	Overdriven 74Rd	G2	Piano	-	63	12	6
				E.Piano	74Rd Stage			
				Sub	-			
13	7	CF3	G2	Piano	CF3	63	12	7
				E.Piano	-			
				Sub	-			
13	8	CF3+AnalogPad	G2	Piano	CF3	63	12	8
				E.Piano	-			
				Sub	Analog Pad			

Version 1.20 新機能

このたび、CP88/CP73ではファームウェアのバージョンアップにより、以下の機能が追加されました。
本書では、製品付属の取扱説明書に対して追加または変更となる点についてご説明します。

- Controllers以下の項目をBend Range、Modulation Lever、Foot Controller 1、Foot Controller 2、Receive SWと変更し、操作可能なパラメーターを追加しました。
- LIVE SET [1] - [6]ボタンを使って設定項目を選択できるようになりました。
- [EXIT] + [SETTINGS]で現在選択中の音色を初期化できるようになりました。
- 新規ボイスを追加しました。
- 新規ライブセットサウンドを追加しました。

Controllers 以下の項目変更とパラメーターの追加

[SETTINGS]ボタン → エンコーダーダイヤルでControllersを選択 → 「ENTER」 ボタン

Controllers 以下の項目を Bend Range、Modulation Lever、Foot Controller 1、Foot Controller 2、Receive SW と変更し、操作可能なパラメーターを追加しました。

Controllers

機能名			内容	
Bend Range	Piano		ピッチベンドの範囲を半音単位で設定します。ボイスセクションごとの設定が可能です。 設定値: -24 - +0 - +24 初期設定: +2	
	E.Piano			
	Sub			
Modulation Lever	Assign		モジュレーションレバーに出力されるコントロールチェンジナンバーです。初期設定: 1 (Modulation) NOTE モジュレーションレバーに USB Audio Volume をアサインできるようになりました。	
	Limit Low		モジュレーションレバーを動かしたときに出力される値の上限と下限を設定します。	
	Limit High			
	P.Mod Depth	Piano		鍵盤の音にかけるビブラートの効果の深さを設定します。ボイスセクションごとの設定が可能です。 設定値: 0 - 127 Piano/E.Piano 初期設定: 0 Sub 初期設定: 10 NOTE サブセクションの Ins Effect で「Rotary」を選択している場合、ビブラートが効果しないため、設定値は無効となります。
		E.Piano		
Sub				
P.Mod Speed	Piano		鍵盤の音にかけるビブラートの効果の速さを設定します。ボイスセクションごとの設定が可能です。 設定値: -64 - +63 初期設定: 0 NOTE サブセクションの Ins Effect で「Rotary」を選択している場合、ビブラートが効果しないため、設定値は無効となります。	
	E.Piano			
	Sub			

機能名		内容	
Foot Controller 1	Assign	<p>FOOT CONTROLLER [1]端子に接続した別売のフットコントローラーを操作したときに出力されるコントロールチェンジナンバーです。</p> <p>初期設定: 11 (Expression)</p> <p>NOTE</p> <p>フットコントローラー1 に USB Audio Volume をアサインできるようになりました。</p>	
	Limit Low	フットコントローラーを動かしたときに出力される値の上限と下限を設定します。	
	Limit High	フットコントローラーを動かしたときに出力される値の上限と下限を設定します。	
Foot Controller 2	Assign	<p>FOOT CONTROLLER [2]端子に接続した別売のフットコントローラーを操作したときに出力されるコントロールチェンジナンバーです。</p> <p>初期設定: 4 (Pedal Wah)</p> <p>NOTE</p> <p>フットコントローラー2 に USB Audio Volume をアサインできるようになりました。</p>	
	Limit Low	フットコントローラーを動かしたときに出力される値の上限と下限を設定します。	
	Limit High	フットコントローラーを動かしたときに出力される値の上限と下限を設定します。	
Receive SW	Expression	Piano	各ボイスセクションが外部から受信した MIDI メッセージや、フットスイッチ、およびフットコントローラーの操作によって出力される MIDI メッセージを受信する(On)か、しない(Off)かを設定します。
		E.Piano	
		Sub	
	Sustain	Piano	初期設定: On
		E.Piano	
		Sub	
	Sostenuto	Piano	
		E.Piano	
		Sub	
	Soft	Piano	
		E.Piano	
		Sub	

LIVE SET [1] - [6]ボタンを使った設定項目の選択

MENU画面か、SETTINGS画面を操作中にLIVE SET [1] - [6]ボタン

LIVE SET [1] - [6]ボタンを使って設定項目を選択できるようになりました。LIVE SET [1] - [6]ボタンは、画面に表示されている項目の上から順に対応します。この機能が有効な場合、LIVE SET [1] - [6]ボタンは点灯します。

例) General画面にいるときに、LIVE SET [5] ボタンを押すことで、USB Audio Volumeを選択する

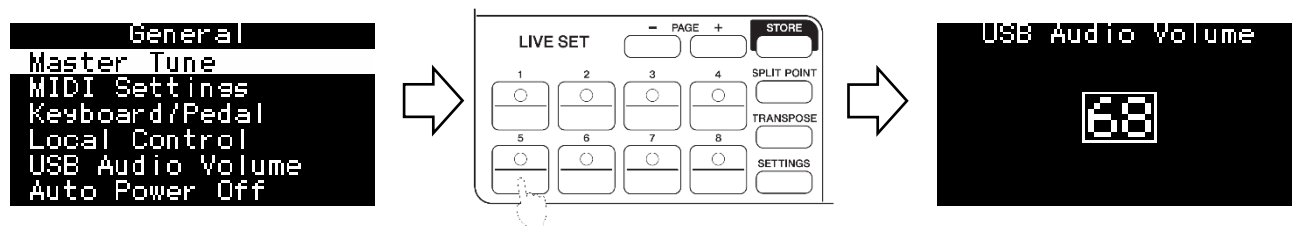

NOTE

項目が7つ以上の場合は、LIVE SET [1] - [6]ボタンを使った設定項目の選択機能は働かず、LIVE SET [1] - [6]ボタンは点灯しません。

[EXIT] + [SETTINGS]で現在選択中の音色を初期化

[EXIT] + [SETTINGS]

[EXIT] + [SETTINGS]で、現在選択中のライブセットサウンドを初期化できるようになりました。現在読み込まれているデータだけが初期化され、保存されているデータは変更しません。

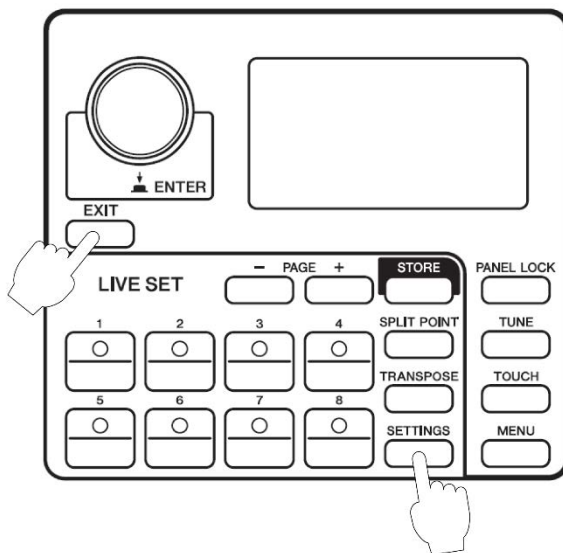

新ボイスの追加

30個の新規ボイス()を追加しました。

Voice List

Section	Category	No.	Voice	CC No.	
PIANO	Grand Piano	01	CFX	1	
		02	Imperial	2	
		03	S700	3	
		04	Digi Piano	4	
		05	C7	58	
	Upright Piano	01	U1	5	
		02	SU7	6	
	CP	01	CP80 1	7	
		02	CP80 2	8	
	Layered Piano	01	Piano Strings	9	
02		Piano Synth	10		
E.PIANO	Rd	01	78Rd	11	
		02	75Rd Funky	12	
		03	73Rd	13	
		04	67Rd Dark	59	
		05	67Rd Bright	60	
	Wr	01	Wr Warm	14	
		02	Wr Bright	15	
		03	Wr Wide	61	
	Clv	01	Clavi B	16	
		02	Clavi S	17	
		03	Harpsichord	18	
	DX	01	DX Legend	19	
		02	DX Woody	20	
		03	DX FTine	21	
		04	DX 7 II	22	
		05	DX Mellow	23	
		06	DX Crisp	24	
	SUB	Pad/Strings	01	Mellow Pad	25
			02	Spectrum	26
03			Back Pad	27	
04			Air Choir	28	
05			Natural Str	29	
06			Warm Strings	30	
07			OB Strings	31	
08			Section Str	32	
09			Fat Saw Pad	62	
10			Noble Pad	63	
11			Pop Pad	64	
12			Analog Pad	65	
13			Itopia	66	
14			Marcato Str	67	
15			Slow Str	68	
16			Tape Str	69	
17			Oct Syn Str	70	
Organ		01	Bright Bars	33	
		02	Click Organ	34	
		03	Draw Organ 1	35	
		04	All Bars Out	36	
		05	Draw Organ 2	37	
		06	60s Combo	38	
		07	Compact	39	
		08	Panther	40	
		09	Pipe Organ 1	41	
		10	Pipe Organ 2	42	
Chromatic Perc.		01	Glocken	43	
		02	Vibraphone	44	
		03	Xylophone	45	
		04	Marimba	46	
		05	Brightness	47	
		06	Jazz Vibes	71	
		07	Marimba 2	72	
		08	Kalimba	73	
		09	Heaven Bell	74	
		10	Nice Bell	48	
		11	Stack Bell	49	

Section	Category	No.	Voice	CC No.
SUB	Others	01	Syn Lead 1	50
		02	Syn Lead 2	51
		03	Syn Bass	52
		04	E.Bass	53
		05	A.Bass	54
		06	Steel Gt	55
		07	Clean Gt	56
		08	Syn Brass	57
		09	Sine Lead	75
		10	Sync Saw	76
		11	Dirty Hook	77
		12	Classic Mini	78
		13	Funky Mini	79
		14	Nu Mini	80
		15	80s Pop Bass	81
		16	Sub Bass	82
		17	Unison Bass	83
		18	Finger Bass	84
		19	Brass	85
		20	Syn Brass 2	86
		21	OB Brass 1	87
		22	OB Brass 2	88
		23	Jazz Flute	89
		24	Tape Flute	90
		25	Harmonica	91

新ライブセットサウンドの追加

新規ボイスを使った新規ライブセットサウンド()が追加されました。

Live Set Sound List

Page	No	Name	Split Point	Section	Voice Name	MSB	LSB	PC
1	1	Natural CFX	G2	Piano	CFX	63	0	1
				E.Piano	-			
				Sub	-			
1	2	NaturalImperial	G2	Piano	Imperial	63	0	2
				E.Piano	-			
				Sub	-			
1	3	Jazz S700	G2	Piano	S700	63	0	3
				E.Piano	-			
				Sub	-			
1	4	Rock Upright	G2	Piano	U1	63	0	4
				E.Piano	-			
				Sub	-			
1	5	Simple 78	G2	Piano	-	63	0	5
				E.Piano	78Rd			
				Sub	-			
1	6	Funky Times	G2	Piano	-	63	0	6
				E.Piano	75Rd Funky			
				Sub	-			
1	7	Tremolo Wr	G2	Piano	-	63	0	7
				E.Piano	Wr Warm			
				Sub	-			
1	8	Clavi B Amped	G2	Piano	-	63	0	8
				E.Piano	Clavi B			
				Sub	-			
2	1	CFX+DX Legend	G2	Piano	CFX	63	1	1
				E.Piano	DX Legend			
				Sub	-			
2	2	A.Bass/78Rd	G2	Piano	U1	63	1	2
				E.Piano	78Rd			
				Sub	A.Bass			
2	3	80s El Grand	G2	Piano	CP80 1	63	1	3
				E.Piano	-			
				Sub	-			
2	4	Brite Pop 8ve	G2	Piano	Digi Piano	63	1	4
				E.Piano	DX Legend			
				Sub	OB Strings			
2	5	E.Bass/78Rd	G2	Piano	-	63	1	5
				E.Piano	78Rd			
				Sub	E.Bass			
2	6	Driven Wr+Pad	G2	Piano	-	63	1	6
				E.Piano	Wr Warm			
				Sub	Warm Strings			
2	7	Imperial + Str	G2	Piano	Imperial	63	1	7
				E.Piano	-			
				Sub	Section Str			
2	8	Ghostly U1	G2	Piano	U1	63	1	8
				E.Piano	Wr Warm			
				Sub	-			
3	1	Rock Grand	G2	Piano	CFX	63	2	1
				E.Piano	-			
				Sub	-			
3	2	S700 + Pad	G2	Piano	S700	63	2	2
				E.Piano	-			
				Sub	OB Strings			
3	3	MonoCmp CFX	G2	Piano	CFX	63	2	3
				E.Piano	-			
				Sub	-			
3	4	Lo Fi Grand	G2	Piano	CFX	63	2	4
				E.Piano	-			
				Sub	-			
3	5	Piano Grind Pad	G2	Piano	Piano Synth	63	2	5
				E.Piano	73Rd			
				Sub	Mellow Pad			
3	6	Lush Love	G2	Piano	Imperial	63	2	6
				E.Piano	78Rd			
				Sub	Brightness			

Page	No	Name	Split Point	Section	Voice Name	MSB	LSB	PC
3	7	Big S700	G2	Piano	S700	63	2	7
				E.Piano	73Rd			
				Sub	OB Strings			
3	8	Piano Scape	G2	Piano	Imperial	63	2	8
				E.Piano	DX Legend			
				Sub	Mellow Pad			
4	1	Compressed CFX	G2	Piano	CFX	63	3	1
				E.Piano	-			
				Sub	-			
4	2	Kinda Squashed	G2	Piano	Imperial	63	3	2
				E.Piano	-			
				Sub	-			
4	3	Layered CFX	G2	Piano	CFX	63	3	3
				E.Piano	75Rd Funky			
				Sub	Mellow Pad			
4	4	Chorus CFX	G2	Piano	CFX	63	3	4
				E.Piano	-			
				Sub	-			
4	5	Upright	G2	Piano	U1	63	3	5
				E.Piano	-			
				Sub	-			
4	6	A Tacky Piano	G2	Piano	SU7	63	3	6
				E.Piano	75Rd Funky			
				Sub	Brightness			
4	7	HonkyTonk Piano	G2	Piano	U1	63	3	7
				E.Piano	-			
				Sub	-			
4	8	Old Record	G2	Piano	U1	63	3	8
				E.Piano	-			
				Sub	-			
5	1	Case 73	G2	Piano	-	63	4	1
				E.Piano	73Rd			
				Sub	-			
5	2	Chimin' Times	G2	Piano	Digi Piano	63	4	2
				E.Piano	78Rd			
				Sub	Glocken			
5	3	Slow Phase	G2	Piano	-	63	4	3
				E.Piano	73Rd			
				Sub	-			
5	4	73 Times OD	G2	Piano	-	63	4	4
				E.Piano	73Rd			
				Sub	-			
5	5	Fast Phaser	G2	Piano	-	63	4	5
				E.Piano	75Rd Funky			
				Sub	-			
5	6	Ampy Funk	G2	Piano	-	63	4	6
				E.Piano	75Rd Funky			
				Sub	-			
5	7	Wet Phase	G2	Piano	-	63	4	7
				E.Piano	78Rd			
				Sub	-			
5	8	78 & Pad	G2	Piano	-	63	4	8
				E.Piano	78Rd			
				Sub	Mellow Pad			
6	1	Wr Bright	G2	Piano	-	63	5	1
				E.Piano	Wr Bright			
				Sub	-			
6	2	Wr Comp	G2	Piano	-	63	5	2
				E.Piano	Wr Warm			
				Sub	-			
6	3	Clavi B	G2	Piano	-	63	5	3
				E.Piano	Clavi B			
				Sub	-			
6	4	Driven S	G2	Piano	-	63	5	4
				E.Piano	Clavi S			
				Sub	-			

Page	No	Name	Split Point	Section	Voice Name	MSB	LSB	PC
6	5	Clavi Wah Dist	G2	Piano	-	63	5	5
				E.Piano	Clavi B			
				Sub	-			
6	6	Squeeze B	G2	Piano	-	63	5	6
				E.Piano	Clavi B			
				Sub	-			
6	7	Long Chorus S	G2	Piano	-	63	5	7
				E.Piano	Clavi S			
				Sub	-			
6	8	Rock Wr w/Ba	G2	Piano	Digi Piano	63	5	8
				E.Piano	Wr Bright			
				Sub	E.Bass			
7	1	CP80 Comp	G2	Piano	CP80 1	63	6	1
				E.Piano	-			
				Sub	-			
7	2	Natural CP80	G2	Piano	CP80 2	63	6	2
				E.Piano	-			
				Sub	-			
7	3	Chorus Legend	G2	Piano	-	63	6	3
				E.Piano	DX Legend			
				Sub	-			
7	4	Chorus FTine	G2	Piano	-	63	6	4
				E.Piano	DX FTine			
				Sub	Mellow Pad			
7	5	Chorus 7II	G2	Piano	-	63	6	5
				E.Piano	DX 7 II			
				Sub	-			
7	6	Legend + Pad	G2	Piano	-	63	6	6
				E.Piano	DX Legend			
				Sub	OB Strings			
7	7	SynBass/DXEP	G2	Piano	-	63	6	7
				E.Piano	DX Mellow			
				Sub	Syn Bass			
7	8	Digi DX Pads	G2	Piano	Digi Piano	63	6	8
				E.Piano	DX Legend			
				Sub	Mellow Pad			
8	1	Bright Bars	G2	Piano	-	63	7	1
				E.Piano	-			
				Sub	Bright Bars			
8	2	All Bars Out	G2	Piano	-	63	7	2
				E.Piano	-			
				Sub	All Bars Out			
8	3	PipeOrgan1	G2	Piano	-	63	7	3
				E.Piano	-			
				Sub	Pipe Organ 1			
8	4	PipeOrgan2	G2	Piano	-	63	7	4
				E.Piano	-			
				Sub	Pipe Organ 2			
8	5	The Red Combo	G2	Piano	-	63	7	5
				E.Piano	-			
				Sub	60s Combo			
8	6	Italian Combo	G2	Piano	-	63	7	6
				E.Piano	-			
				Sub	Compact			
8	7	Aggro Syn Pad	G2	Piano	-	63	7	7
				E.Piano	78Rd			
				Sub	Panther			
8	8	RdBa/60sCombo	G2	Piano	-	63	7	8
				E.Piano	78Rd			
				Sub	60s Combo			
9	1	Strings1	G2	Piano	-	63	8	1
				E.Piano	-			
				Sub	Natural Str			
9	2	Strings2	G2	Piano	-	63	8	2
				E.Piano	-			
				Sub	Section Str			
9	3	Synth Pad1	G2	Piano	-	63	8	3
				E.Piano	-			
				Sub	Mellow Pad			
9	4	Synth Pad2	G2	Piano	-	63	8	4
				E.Piano	-			
				Sub	Warm Strings			
9	5	Vibraphone	G2	Piano	-	63	8	5
				E.Piano	-			
				Sub	Vibraphone			
9	6	Nice Bell	G2	Piano	-	63	8	6
				E.Piano	-			
				Sub	Nice Bell			

Page	No	Name	Split Point	Section	Voice Name	MSB	LSB	PC
9	7	Syn Brass	G2	Piano	-	63	8	7
				E.Piano	-			
				Sub	Syn Brass			
9	8	Syn Lead1	G2	Piano	-	63	8	8
				E.Piano	78Rd			
				Sub	Syn Lead 1			
10	1	Harpischord	G2	Piano	-	63	9	1
				E.Piano	Harpischord			
				Sub	-			
10	2	Electric Harpsi	G2	Piano	-	63	9	2
				E.Piano	Harpischord			
				Sub	-			
10	3	Pipes Rd PBMW	G2	Piano	Digi Piano	63	9	3
				E.Piano	78Rd			
				Sub	Pipe Organ 2			
10	4	Funky w/RdBass	G2	Piano	CP80 1	63	9	4
				E.Piano	78Rd			
				Sub	Marimba			
10	5	Rough Lead	G2	Piano	CP80 2	63	9	5
				E.Piano	78Rd			
				Sub	Back Pad			
10	6	Clavi Syn Wah	G2	Piano	-	63	9	6
				E.Piano	Clavi B			
				Sub	Syn Lead 1			
10	7	Chimin' Crs	G2	Piano	Digi Piano	63	9	7
				E.Piano	75Rd Funky			
				Sub	Glocken			
10	8	Brite Pop	G2	Piano	Digi Piano	63	9	8
				E.Piano	DX Legend			
				Sub	OB Strings			
11	1	Back to 60s SP	G2	Piano	-	63	10	1
				E.Piano	67Rd Dark			
				Sub	-			
11	2	80s Piano JG	G2	Piano	C7	63	10	2
				E.Piano	78Rd			
				Sub	-			
11	3	NaturalWrWideJG	G2	Piano	-	63	10	3
				E.Piano	Wr Wide			
				Sub	-			
11	4	Chorused67Rd SP	G2	Piano	-	63	10	4
				E.Piano	67Rd Bright			
				Sub	-			
11	5	R&B Ballad NS	G2	Piano	-	63	10	5
				E.Piano	67Rd Dark			
				Sub	-			
11	6	Squashed C7 NS	G2	Piano	C7	63	10	6
				E.Piano	-			
				Sub	-			
11	7	WrWideChorus SP	G2	Piano	-	63	10	7
				E.Piano	Wr Wide			
				Sub	-			
11	8	Driven 67Rd JG	G2	Piano	-	63	10	8
				E.Piano	67Rd Bright			
				Sub	-			
12	1	CFX + Slow Str	G2	Piano	CFX	63	11	1
				E.Piano	-			
				Sub	Slow Str			
12	2	C7 + Noble Pad	G2	Piano	C7	63	11	2
				E.Piano	-			
				Sub	Noble Pad			
12	3	78Rd+AnalogPad	G2	Piano	-	63	11	3
				E.Piano	78Rd			
				Sub	Analog Pad			
12	4	78Rd+OBBrass MW	G2	Piano	-	63	11	4
				E.Piano	78Rd			
				Sub	OB Brass 1			
12	5	Sync Saw/DX EP	C3	Piano	-	63	11	5
				E.Piano	DX Legend			
				Sub	Sync Saw			
12	6	Fat Saw Pad MW	G2	Piano	-	63	11	6
				E.Piano	-			
				Sub	Fat Saw Pad			
12	7	OB Brass	G2	Piano	-	63	11	7
				E.Piano	-			
				Sub	OB Brass 2			
12	8	Marcato Str	G2	Piano	-	63	11	8
				E.Piano	-			
				Sub	Marcato Str			

Version 1.10 新機能

このたび、CP88/CP73ではファームウェアのバージョンアップにより、以下の機能が追加されました。
本書では、製品付属の取扱説明書に対して追加または変更となる点についてご説明します。

- 全データファイルから1ライブセットサウンド単位でのロードができるようになりました。
- 「Advanced Settings」に「MIDI Control Delay」項目を追加しました。
- 新規ボイスを追加しました。
- 新規ライブセットサウンドを追加しました。
- Soundmondoに対応しました。

全データファイルから 1 ライブセットサウンド単位でロードする

[MENU]ボタン → 「File」画面 → 本体に読み込む内容を選択 → 「Load Live Set Sound」または「Load All」

複数のライブセットサウンドが含まれるデータ（「Backup File」、「Live Set File」、「Live Set Page File」）から1ライブセットサウンド単位でのロードができるようになりました。

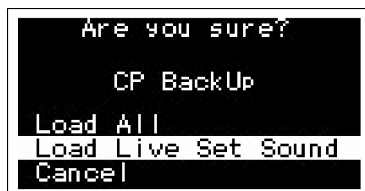

上記の該当ファイルを選択すると、以下の画面が表示されます。

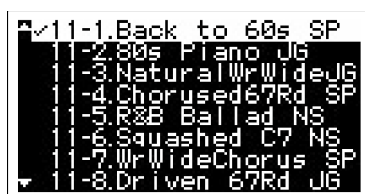

「Load Live Set Sound」を選択すると以下の画面が表示され、必要なライブセットサウンドをロードできます。ロード先は、現在選ばれているライブセットサウンドになります。「Load All」を選択すると、ファイルに含まれるすべてのライブセットサウンドをロードできます。

MIDI Control Delay の追加

[MENU]ボタン → 「Control Panel」画面 → 「Advanced Settings」 → 「MIDI Control Delay」

Live Set Sound切り替えの際に出力するコントロールチェンジの送信タイミングを調整するため、「Advanced Settings」に「MIDI Control Delay」項目を追加しました。

コンピューター上のアプリケーションがコントロールチェンジを正しく受信できないときは、この設定を変更することで送信タイミングを調整できます。

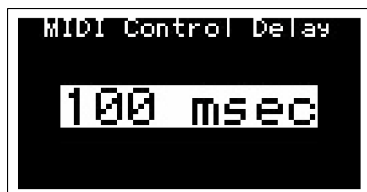

設定値: 0 msec - 1500 msec

初期設定: 0 msec

新ボイスの追加

4個の新規ボイス()を追加しました。

Voice List

Section	Category	No.	Voice	CC No.	
PIANO	Grand Piano	01	CFX	1	
		02	Imperial	2	
		03	S700	3	
		04	Digi Piano	4	
		05	C7	58	
	Upright Piano	01	U1	5	
		02	SU7	6	
	CP	03	CP80 1	7	
		04	CP80 2	8	
	Layered Piano	05	Piano Strings	9	
06		Piano Synth	10		
E.PIANO	Rd	07	78Rd	11	
		08	75Rd Funky	12	
		09	73Rd	13	
		10	67Rd Dark	59	
		11	67Rd Bright	60	
	Wr	12	Wr Warm	14	
		13	Wr Bright	15	
		14	Wr Wide	61	
	Clv	15	Clavi B	16	
		16	Clavi S	17	
		17	Harpsichord	18	
	DX	18	DX Legend	19	
		19	DX Woody	20	
		20	DX FTine	21	
		21	DX 7 II	22	
		22	DX Mellow	23	
		23	DX Crisp	24	
	SUB	Pad/Strings	24	Mellow Pad	25
			25	Spectrum	26
			26	Back Pad	27
			27	Air Choir	28
			28	Natural Str	29
			29	Warm Strings	30
30			OB Strings	31	
31			Section Str	32	
Organ			32	Bright Bars	33
			33	Click Organ	34
			34	Draw Organ 1	35
		35	All Bars Out	36	
		36	Draw Organ 2	37	
		37	60s Combo	38	
		38	Compact	39	
		39	Panther	40	
		40	Pipe Organ 1	41	
		41	Pipe Organ 2	42	
Chromatic Perc.		42	Glocken	43	
		43	Vibraphone	44	
		44	Xylophone	45	
		45	Marimba	46	
		46	Brightness	47	
		47	Nice Bell	48	
Others		48	Stack Bell	49	
		49	Syn Lead 1	50	
		50	Syn Lead 2	51	
		51	Syn Bass	52	
		52	E.Bass	53	
		53	A.Bass	54	
		54	Steel Gt	55	
	55	Clean Gt	56		
	56	Syn Brass	57		

新ライブセットサウンドの追加

新規ボイスを使った新規ライブセットサウンド() が追加されました。

Live Set Sound List

Page	No	Name	Split Point	Section	Voice Name	MSB	LSB	PC
1	1	Natural CFX	G2	Piano	CFX	63	0	1
				E.Piano	-			
				Sub	-			
1	2	NaturalImperial	G2	Piano	Imperial	63	0	2
				E.Piano	-			
				Sub	-			
1	3	Jazz S700	G2	Piano	S700	63	0	3
				E.Piano	-			
				Sub	-			
1	4	Rock Upright	G2	Piano	U1	63	0	4
				E.Piano	-			
				Sub	-			
1	5	Simple 78	G2	Piano	-	63	0	5
				E.Piano	78Rd			
				Sub	-			
1	6	Funky Tines	G2	Piano	-	63	0	6
				E.Piano	75Rd Funky			
				Sub	-			
1	7	Tremolo Wr	G2	Piano	-	63	0	7
				E.Piano	Wr Warm			
				Sub	-			
1	8	Clavi B Amped	G2	Piano	-	63	0	8
				E.Piano	Clavi B			
				Sub	-			
2	1	CFX+DX Legend	G2	Piano	CFX	63	1	1
				E.Piano	DX Legend			
				Sub	-			
2	2	A.Bass/78Rd	G2	Piano	U1	63	1	2
				E.Piano	78Rd			
				Sub	A.Bass			
2	3	80s El Grand	G2	Piano	CP80 1	63	1	3
				E.Piano	-			
				Sub	-			
2	4	Brite Pop 8ve	G2	Piano	Digi Piano	63	1	4
				E.Piano	DX Legend			
				Sub	OB Strings			
2	5	E.Bass/78Rd	G2	Piano	-	63	1	5
				E.Piano	78Rd			
				Sub	E.Bass			
2	6	Driven Wr+Pad	G2	Piano	-	63	1	6
				E.Piano	Wr Warm			
				Sub	Warm Strings			
2	7	Imperial + Str	G2	Piano	Imperial	63	1	7
				E.Piano	-			
				Sub	Section Str			
2	8	Ghostly U1	G2	Piano	U1	63	1	8
				E.Piano	Wr Warm			
				Sub	-			
3	1	Rock Grand	G2	Piano	CFX	63	2	1
				E.Piano	-			
				Sub	-			
3	2	S700 + Pad	G2	Piano	S700	63	2	2
				E.Piano	-			
				Sub	OB Strings			
3	3	MonoCmp CFX	G2	Piano	CFX	63	2	3
				E.Piano	-			
				Sub	-			
3	4	Lo Fi Grand	G2	Piano	CFX	63	2	4
				E.Piano	-			
				Sub	-			
3	5	Piano Grind Pad	G2	Piano	Piano Synth	63	2	5
				E.Piano	73Rd			
				Sub	Mellow Pad			
3	6	Lush Love	G2	Piano	Imperial	63	2	6
				E.Piano	78Rd			
				Sub	Brightness			
3	7	Big S700	G2	Piano	S700	63	2	7
				E.Piano	73Rd			
				Sub	OB Strings			

Page	No	Name	Split Point	Section	Voice Name	MSB	LSB	PC
3	8	Piano Scape	G2	Piano	Imperial	63	2	8
				E.Piano	DX Legend			
				Sub	Mellow Pad			
4	1	Compressed CFX	G2	Piano	CFX	63	3	1
				E.Piano	-			
				Sub	-			
4	2	Kinda Squashed	G2	Piano	Imperial	63	3	2
				E.Piano	-			
				Sub	-			
4	3	Layered CFX	G2	Piano	CFX	63	3	3
				E.Piano	75Rd Funky			
				Sub	Mellow Pad			
4	4	Chorus CFX	G2	Piano	CFX	63	3	4
				E.Piano	-			
				Sub	-			
4	5	Upright	G2	Piano	U1	63	3	5
				E.Piano	-			
				Sub	-			
4	6	A Tacky Piano	G2	Piano	SU7	63	3	6
				E.Piano	75Rd Funky			
				Sub	Brightness			
4	7	HonkyTonk Piano	G2	Piano	U1	63	3	7
				E.Piano	-			
				Sub	-			
4	8	Old Record	G2	Piano	U1	63	3	8
				E.Piano	-			
				Sub	-			
5	1	Case 73	G2	Piano	-	63	4	1
				E.Piano	73Rd			
				Sub	-			
5	2	Chimin' Tines	G2	Piano	Digi Piano	63	4	2
				E.Piano	78Rd			
				Sub	Glocken			
5	3	Slow Phase	G2	Piano	-	63	4	3
				E.Piano	73Rd			
				Sub	-			
5	4	73 Tines OD	G2	Piano	-	63	4	4
				E.Piano	73Rd			
				Sub	-			
5	5	Fast Phaser	G2	Piano	-	63	4	5
				E.Piano	75Rd Funky			
				Sub	-			
5	6	Ampy Funk	G2	Piano	-	63	4	6
				E.Piano	75Rd Funky			
				Sub	-			
5	7	Wet Phase	G2	Piano	-	63	4	7
				E.Piano	78Rd			
				Sub	-			
5	8	78 & Pad	G2	Piano	-	63	4	8
				E.Piano	78Rd			
				Sub	Mellow Pad			
6	1	Wr Bright	G2	Piano	-	63	5	1
				E.Piano	Wr Bright			
				Sub	-			
6	2	Wr Comp	G2	Piano	-	63	5	2
				E.Piano	Wr Warm			
				Sub	-			
6	3	Clavi B	G2	Piano	-	63	5	3
				E.Piano	Clavi B			
				Sub	-			
6	4	Driven S	G2	Piano	-	63	5	4
				E.Piano	Clavi S			
				Sub	-			
6	5	Clavi Wah Dist	G2	Piano	-	63	5	5
				E.Piano	Clavi B			
				Sub	-			
6	6	Squeeze B	G2	Piano	-	63	5	6
				E.Piano	Clavi B			
				Sub	-			

Page	No	Name	Split Point	Section	Voice Name	MSB	LSB	PC
6	7	Long Chorus S	G2	Piano	-	63	5	7
				E.Piano	Clavi S			
				Sub	-			
6	8	Rock Wr w/Ba	G2	Piano	Digi Piano	63	5	8
				E.Piano	Wr Bright			
				Sub	E.Bass			
7	1	CP80 Comp	G2	Piano	CP80 1	63	6	1
				E.Piano	-			
				Sub	-			
7	2	Natural CP80	G2	Piano	CP80 2	63	6	2
				E.Piano	-			
				Sub	-			
7	3	Chorus Legend	G2	Piano	-	63	6	3
				E.Piano	DX Legend			
				Sub	-			
7	4	Chorus FTine	G2	Piano	-	63	6	4
				E.Piano	DX FTine			
				Sub	Mellow Pad			
7	5	Chorus 7II	G2	Piano	-	63	6	5
				E.Piano	DX 7 II			
				Sub	-			
7	6	Legend + Pad	G2	Piano	-	63	6	6
				E.Piano	DX Legend			
				Sub	OB Strings			
7	7	SynBass/DXEP	G2	Piano	-	63	6	7
				E.Piano	DX Mellow			
				Sub	Syn Bass			
7	8	Digi DX Pads	G2	Piano	Digi Piano	63	6	8
				E.Piano	DX Legend			
				Sub	Mellow Pad			
8	1	Bright Bars	G2	Piano	-	63	7	1
				E.Piano	-			
				Sub	Bright Bars			
8	2	All Bars Out	G2	Piano	-	63	7	2
				E.Piano	-			
				Sub	All Bars Out			
8	3	PipeOrgan1	G2	Piano	-	63	7	3
				E.Piano	-			
				Sub	Pipe Organ 1			
8	4	PipeOrgan2	G2	Piano	-	63	7	4
				E.Piano	-			
				Sub	Pipe Organ 2			
8	5	The Red Combo	G2	Piano	-	63	7	5
				E.Piano	-			
				Sub	60s Combo			
8	6	Italian Combo	G2	Piano	-	63	7	6
				E.Piano	-			
				Sub	Compact			
8	7	Aggro Syn Pad	G2	Piano	-	63	7	7
				E.Piano	78Rd			
				Sub	Panther			
8	8	RdBa/60sCombo	G2	Piano	-	63	7	8
				E.Piano	78Rd			
				Sub	60s Combo			
9	1	Strings1	G2	Piano	-	63	8	1
				E.Piano	-			
				Sub	Natural Str			
9	2	Strings2	G2	Piano	-	63	8	2
				E.Piano	-			
				Sub	Section Str			
9	3	Synth Pad1	G2	Piano	-	63	8	3
				E.Piano	-			
				Sub	Mellow Pad			

Page	No	Name	Split Point	Section	Voice Name	MSB	LSB	PC
9	4	Synth Pad2	G2	Piano	-	63	8	4
				E.Piano	-			
				Sub	Warm Strings			
9	5	Vibraphone	G2	Piano	-	63	8	5
				E.Piano	-			
				Sub	Vibraphone			
9	6	Nice Bell	G2	Piano	-	63	8	6
				E.Piano	-			
				Sub	Nice Bell			
9	7	Syn Brass	G2	Piano	-	63	8	7
				E.Piano	-			
				Sub	Syn Brass			
9	8	Syn Lead1	G2	Piano	-	63	8	8
				E.Piano	78Rd			
				Sub	Syn Lead 1			
10	1	Harpichord	G2	Piano	-	63	9	1
				E.Piano	Harpichord			
				Sub	-			
10	2	Electric Harpsi	G2	Piano	-	63	9	2
				E.Piano	Harpichord			
				Sub	-			
10	3	Pipes Rd PBMW	G2	Piano	Digi Piano	63	9	3
				E.Piano	78Rd			
				Sub	Pipe Organ 2			
10	4	Funky w/RdBass	G2	Piano	CP80 1	63	9	4
				E.Piano	78Rd			
				Sub	Marimba			
10	5	Rough Lead	G2	Piano	CP80 2	63	9	5
				E.Piano	78Rd			
				Sub	Back Pad			
10	6	Clavi Syn Wah	G2	Piano	-	63	9	6
				E.Piano	Clavi B			
				Sub	Syn Lead 1			
10	7	Chimin' Crs	G2	Piano	Digi Piano	63	9	7
				E.Piano	75Rd Funky			
				Sub	Glocken			
10	8	Brite Pop	G2	Piano	Digi Piano	63	9	8
				E.Piano	DX Legend			
				Sub	OB Strings			
11	1	Back to 60s SP	G2	Piano	-	63	10	1
				E.Piano	67Rd Dark			
				Sub	-			
11	2	80s Piano JG	G2	Piano	C7	63	10	2
				E.Piano	78Rd			
				Sub	-			
11	3	NaturalWrWideJG	G2	Piano	-	63	10	3
				E.Piano	Wr Wide			
				Sub	-			
11	4	Chorused67Rd SP	G2	Piano	-	63	10	4
				E.Piano	67Rd Bright			
				Sub	-			
11	5	R&B Ballad NS	G2	Piano	-	63	10	5
				E.Piano	67Rd Dark			
				Sub	-			
11	6	Squashed C7 NS	G2	Piano	C7	63	10	6
				E.Piano	-			
				Sub	-			
11	7	WrWideChorus SP	G2	Piano	-	63	10	7
				E.Piano	Wr Wide			
				Sub	-			
11	8	Driven 67Rd JG	G2	Piano	-	63	10	8
				E.Piano	67Rd Bright			
				Sub	-			

