



S30

MUSIC SYNTHESIZER

データリスト

目次

S30ボイスリスト.....	2
クイックアクセスボイスリスト.....	8
ドラムボイスリスト.....	9
ウェーブリスト.....	12
パフォーマンスリスト.....	13
コントロールリスト.....	14
アルペジオタイプリスト.....	15
エフェクトタイプリスト.....	16
エフェクトパラメーターリスト.....	16
MIDIについて.....	25
MIDIデータフォーマット.....	25
MIDIデータテーブル.....	29
MIDIインプリメンテーションチャート.....	37



S30ボイスリスト

Preset 1 (MSB=63, LSB=0)

No.	Voice Name	Category	Reverb Type	Chorus Type	Insertion1 Type	Insertion2 Type	MW	PB	AT	FC	BC	FS	Kn1	Kn2
1(A01)	StereoGrnd	Pf	Hall 1	Chorus 1	3band EQ	Thru	ChoSend	off	off	off	off	off	ChoSend	RevSend
2(A02)	StereoGnd2	Pf	Hall 1	Chorus 1	3band EQ	Thru	ChoSend	off	off	off	off	off	FLT-Frq	RevSend
3(A03)	CF Grand M	Pf	Hall 1	Chorus 1	3band EQ	Thru	ChoSend	off	off	off	off	off	ChoSend	RevSend
4(A04)	Dark Grand	Pf	Hall 1	Chorus 1	Thru	Thru	ChoSend	off	off	off	off	off	FLT-Frq	RevSend
5(A05)	Difference	Pf	Hall 1	Chorus 1	3band EQ	Thru	ChoSend	off	off	off	off	off	FLT-Frq	RevSend
6(A06)	Piano/Ep	Pf	Hall 1	Chorus 1	Chorus 1	3Band EQ	ChoSend, Volume	off	off	off	off	off	FLT-Frq	ELM-Lvl, ELM-Lvl
7(A07)	Piano/Strg	Co	Hall 1	Chorus 1	3band EQ	Thru	ELM-Lvl	off	off	off	off	off	FLT-Frq	RevSend
8(A08)	Piano/Oohs	Pf	Hall 1	Chorus 1	3band EQ	Thru	ELM-Lvl	off	off	off	off	off	FLT-Frq	RevSend
9(A09)	CP2000	Pf	Hall 1	Flanger 3	3band EQ	Thru	ChoSend	off	off	off	off	off	ELM-Lvl	FLT-Frq
10(A10)	Piano/DX	Pf	Hall 1	Chorus 1	3band EQ	Chorus 5	CLFO-D1	off	off	off	off	off	ChoSend, Volume	RevSend
11(A11)	Wurlitm	Pf	Room 1	Celeste 1	Thru	Tremolo	InsL prm2, Volume	off	off	off	off	off	FLT-Frq	ChoSend, RevSend
12(A12)	DF EP IV	Pf	Hall 1	Chorus 1	3band EQ	Pitch Change 1	InsL prm2	off	off	off	off	off	FLT-Frq	ChoSend, RevSend
13(A13)	DF EP III	Pf	Hall 2	Chorus 1	Compressor	Celeste 1	InsL prm3, InsL prm1	off	off	off	off	off	InsL prm10	RevSend
14(A14)	Herb Roadz	Pf	Hall 2	Chorus 1	Auto Pan	Comp Distortion	InsS prm1	off	off	off	off	off	InsS prm2	RevSend
15(A15)	BasicRoadz	Pf	Hall 2	Chorus 1	3band EQ	Auto Pan	InsL prm1	off	off	off	off	off	InsL prm2	ChoSend, RevSend
16(A16)	19 Roadz	Pf	Stage 2	Chorus 1	Compressor	Phaser 1	InsL prm2	off	off	off	off	off	InsL prm4	RevSend
17(B01)	Vic'sRoadz	Pf	Hall 1	Celeste 2	3band EQ	Auto Pan	InsL prm2, InsL prm1	off	off	off	off	off	ChoSend	RevSend
18(B02)	EryFusion	Pf	Hall 1	Phaser	Touch Wah	3Band EQ	CLFO-D1	off	off	off	off	off	RevSend	ChoSend
19(B03)	Grapevine	Pf	Room 2	Chorus 1	Auto Pan	V-Distortion	ELFO-PM	off	off	off	off	off	AEG-D1	RevSend
20(B04)	VintgCond	Pf	Hall 1	Chorus 1	3band EQ	Auto Pan	InsL prm1, InsL prm2, InsL prm3	off	off	off	off	off	RevSend	ChoSend
21(B05)	DXAttack	Pf	Hall 1	Celeste 1	Chorus 3	Thru	CLFO-D1	off	off	off	off	off	RevSend	ChoSend
22(B06)	Digix Wave	Pf	Hall 1	Chorus 5	3band EQ	Thru	CLFO-D1	off	off	off	off	off	RevSend	ChoSend
23(B07)	Dark DX	Pf	Hall 1	Chorus 1	Thru	Thru	CLFO-D1	off	off	off	off	off	FLT-Frq	ChoSend, RevSend
24(B08)	Ice Piano	Pf	Hall 1	Chorus 1	Thru	Thru	CLFO-D1	off	off	off	off	off	FLT-Frq	ChoSend, RevSend
25(B09)	ChorusBel	Pf	Stage 1	Delay LR	3band EQ	Ensemble Detune	InsL prm10	off	off	off	off	off	RevSend	ChoSend
26(B10)	Bel Roadz	Pf	Hall 1	Chorus 4	Thru	Thru	ELFO-AM	off	off	off	off	off	RevSend	ELFOSpd
27(B11)	Glass EP	Pf	Hall 1	Chorus 1	Thru	Thru	ELFO-AM	off	off	off	off	off	RevSend	ChoSend
28(B12)	SuperDyno	Pf	Hall 1	Chorus 1	Compressor	Pitch Change 1	InsL prm11, InsL prm13	off	off	off	off	off	InsS prm4, InsS prm3	RevSend
29(B13)	PowerKeys	Sc	Room 1	Chorus 1	3band EQ	Phaser 2	InsL prm2, InsL prm4, InsL prm10	off	off	off	off	off	InsL prm1	RevSend
30(B14)	Harpicorde	Pf	Room 3	Celeste 1	Thru	Thru	ChoSend, Volume	off	off	off	off	off	FLT-Frq	FEG-D1
31(B15)	Clav	Pf	Stage 2	Celeste 1	Thru	Thru	ChoSend, Volume	off	off	off	off	off	FLT-Frq	AEG-D1, AEG-D2
32(B16)	Clav Wah	Pf	Stage 2	Phaser	Touch Wah	Thru	ChoSend, Volume	RevSend	off	off	off	off	FLT-Frq	FEG-D1
33(C01)	Perc Org	Or	Hall 1	Chorus 1	3band EQ	2Way Rotary Speaker 3	InsL prm16, ChoSend, ELM-Lvl	off	off	off	off	off	InsL prm9	RevSend
34(C02)	Cool	Or	Room 1	Chorus 1	Thru	2Way Rotary Speaker 3	InsL prm16	off	off	off	off	off	InsL prm9	InsL prm1
35(C03)	ClickOrgan	Or	Hall 1	Chorus 1	Overdrive	Rotary Speaker 1	InsL prm1	off	off	off	off	off	ELM-Lvl	ELM-Lvl
36(C04)	Jazz	Or	Room 1	Chorus 1	Overdrive	Rotary Speaker 1	InsL prm1	off	off	off	off	off	InsL prm9	InsL prm1
37(C05)	Soft Rock	Or	Hall 1	Chorus 1	Overdrive	Rotary Speaker 1	InsL prm1, ChoSend, ELM-Lvl	off	off	off	off	off	InsS prm10	ChoSend
38(C06)	Tube	Or	Hall 1	Chorus 3	AMP Simulator	2Way Rotary Speaker 3	InsL prm16, InsL prm9	off	off	off	off	off	InsS prm1, Volume	InsL prm9, FLT-Frq
39(C07)	Contnental	Or	Stage 1	Chorus 1	3band EQ	2Way Rotary Speaker	InsL prm1	off	off	off	off	off	FLT-Frq	RevSend
40(C08)	Swish	Or	Room 1	Chorus 1	Thru	Thru	ChoSend, Volume	off	off	off	off	off	FLT-Frq	RevSend
41(C09)	4 Bars	Or	Hall 1	Chorus 1	Overdrive	Rotary Speaker 1	InsL prm1	off	off	off	off	off	RevSend	ELM-Lvl
42(C10)	Full	Or	Hall 1	Chorus 1	3band EQ	2Way Rotary Speaker 3	InsL prm16, ChoSend, ELM-Lvl	off	off	off	off	off	ELM-Lvl	ELM-Lvl
43(C11)	GiantDrbr	Or	Room 1	Chorus 1	Thru	2Way Rotary Speaker 3	InsL prm16	InsL prm2, InsL prm3	off	off	off	off	InsL prm14	InsL prm5, InsL prm6
44(C12)	Sunday	Or	Hall 2	Chorus 3	2band EQ	Thru	FLT-Frq	off	off	off	off	off	ELM-Lvl	RevSend
45(C13)	Pipes	Or	Hall 2	Chorus 3	Thru	Thru	ChoSend	off	off	off	off	off	RevSend	ELFO-PM
46(C14)	New Nylon	Gt	Hall 1	Chorus 1	3band EQ	Thru	CLFO-D1	off	off	off	off	off	ELM-Lvl	ELM-Lvl, FLT-Frq
47(C15)	JazzGTmelo	Gt	Hall 1	Chorus 1	3band EQ	3Band EQ	CLFO-D1	off	off	off	off	off	InsS prm4	ChoSend
48(C16)	Melo Trmlo	Gt	Hall 1	Delay LR	Tremolo	Comp Distortion	FLT-Frq	off	off	off	off	off	InsS prm1	InsS prm2
49(D01)	Strat Chor	Gt	Hall 1	Delay LR	Chorus 1	Comp Distortion	ELFO-PM	off	off	off	off	off	InsL prm1, InsL prm4, Volume, InsL prm14	InsS prm10
50(D02)	StratChor2	Gt	Hall 1	Chorus 4	3band EQ	AMP Simulator	ELFO-PM	off	off	off	off	off	ChoSend, Volume	RevSend
51(D03)	18 String	Gt	Hall 2	Chorus 1	3band EQ	2Band EQ	CLFO-D1	off	off	off	off	off	ChoSend	FLT-Frq
52(D04)	Acoustic	Gt	Hall 1	Chorus 1	Thru	Thru	ELFO-PM	off	off	off	off	off	FEG-D1	ChoSend
53(D05)	MuteGr	Gt	Room 3	Phaser	Thru	Compressor	ELFO-PM, ChoSend	off	off	off	off	off	FLT-Frq, FLT-Rez	ChoSend
54(D06)	DirtyTwn	Gt	Room 3	Chorus 4	3band EQ	V-Distortion	ELFO-PM	off	off	off	off	off	InsL prm1	InsL prm11, RevSend
55(D07)	Feedback	Gt	Room 3	Chorus 4	3band EQ	V-Distortion	ELFO-PM	off	off	off	off	off	InsL prm1	InsL prm11, RevSend
56(D08)	VOODOO MAN	Gt	Room 3	Phaser	Touch Wah	V-Distortion	ELFO-PM, InsS prm4	off	InsS prm2	off	off	off	InsL prm1	InsL prm11
57(D09)	Rockability	Gt	Room 3	Chorus 4	3band EQ	V-Distortion	ELFO-PM	off	off	off	off	off	InsL prm1, Volume	InsL prm11, RevSend
58(D10)	Funk It!!!	Gt	Room 3	Delay LR	Compressor	Auto WAH Overdrive	FLT-Frq	off	off	off	off	off	InsS prm3, Volume	ChoSend
59(D11)	Upright	Ba	Room 1	Chorus 1	3band EQ	Thru	ELFO-PM	off	off	off	off	off	FLT-Frq, FLT-Frq	ELM-Lvl
60(D12)	Finger	Ba	Room 3	Chorus 4	Compressor	Thru	CLFO-D1	off	off	off	off	off	InsS prm3, Volume	ChoSend
61(D13)	PickBass	Ba	Room 1	Chorus 1	Thru	Thru	ELFO-PM	off	off	off	off	off	FLT-Frq	ChoSend, RevSend
62(D14)	Fretless	Ba	Hall 1	Chorus 1	3band EQ	Thru	ELFO-PM	off	off	off	off	off	FLT-Frq	ChoSend, RevSend
63(D15)	Slap	Ba	Room 1	Chorus 1	Compressor	Thru	ELFO-PM	off	off	off	off	off	FLT-Frq	ChoSend, RevSend
64(D16)	Fngr & RW	Ba	Room 1	Chorus 1	Thru	Thru	ELFO-PM	off	ELFO-PM	off	off	off	FLT-Frq, FLT-Frq	ChoSend, RevSend

No.	Voice Name	Category	Reverb Type	Chorus Type	Insertion1 Type	Insertion2 Type	MW	PB	AT	FC	BC	FS	Kn1	Kn2
65(E01)	Background	St	Hall 2	Chorus 1	3band EQ	3Band EQ	CLFO-D1	off	off	off	off	off	ChoSend, RevSend	AEG-Atk, AEG-Rel
66(E02)	Big String	St	Hall 1	Chorus 1	Thru	Thru	ELFO-PM	off	off	off	off	off	RevSend	FLT-Frq, FLT-Rez
67(E03)	Cello Big	St	Hall 1	Chorus 1	Thru	Thru	FLT-Frq	off	off	off	off	off	AEG-Rel, AEG-Atk	ChoSend, RevSend
68(E04)	Chamberz	St	Hall 1	Chorus 1	Thru	Thru	ELFO-PM	off	off	off	off	off	RevSend	FLT-Frq, FLT-Rez
69(E05)	SmallSect	St	Hall 1	Chorus 1	3band EQ	Thru	ChoSend, Volume	off	off	off	off	off	FLT-Frq	AEG-Atk, AEG-Rel
70(E06)	CelloSmall	St	Hall 1	Chorus 1	Thru	Thru	FLT-Frq	off	off	off	off	off	AEG-Rel, AEG-Atk	ChoSend, RevSend, Volume
71(E07)	Pizz	St	Hall 1	Chorus 3	Thru	Thru	ChoSend	off	off	off	off	off	FLT-Frq	AEG-D1
72(E08)	Harp	St	Hall 1	Celeste 2	Thru	Thru	ELFO-PM	off	off	off	off	off	RevSend	ChoSend
73(E09)	Oboe	Rd	Hall 1	Chorus 1	Thru	Thru	ELFO-PM, ELFO-AM	off	off	off	off	off	RevSend	FLT-Frq
74(E10)	Bssoon	Rd	Hall 1	Chorus 1	Thru	Thru	ELFO-PM	ELFO-AM	off	off	off	off	RevSend	FLT-Frq
75(E11)	Clarnet	Rd	Hall 1	Chorus 1	3band EQ	Thru	ELFO-PM, ELFO-AM	off	off	off	off	off	RevSend	FLT-Frq, FLT-Rez
76(E12)	Wind Orch	Co	Hall 1	Ensemble	3band EQ	Thru	CLFO-D1, CLFO-D2, ELFO-PM, ELFO-FM	off	off	off	off	off	FLT-Frq	ELM-Lvl
77(E13)	SynthStrgs	St	Hall 1	Chorus 1	3band EQ	Cross Delay	FLT-Frq	off	off	off	off	off	ChoSend, Volume	RevSend
78(E14)	ObiStrings	St	Hall 2	Chorus 5	Exciter	Cross Delay	FLT-Frq, FLT-Rez	off	off	off	off	off	InsS prm1	ChoSend
79(E15)	Fanfare	Br	Hall 1	Chorus 1	3band EQ	Thru	CLFO-D1	off	off	off	off	off	ChoSend, Volume	RevSend
80(E16)	MediumBrss	Br	Hall 1	Chorus 1	3band EQ	Thru	CLFO-D1	off	off	off	off	off	ChoSend, Volume	RevSend
81(F01)	Two Brass	Br	Hall 1	Chorus 1	Thru	Thru	ELFO-FM, ELFO-PM	off	off	off	off	off	FLT-Frq	ChoSend, Volume
82(F02)	Brass&Sax	Br	Hall 1	Chorus 1	Thru	Thru	ELFO-FM, ELFO-PM	off	off	off	off	off	FLT-Frq	ChoSend, Volume
83(F03)	Dark Class	Br	Hall 1	Chorus 1	Thru	Thru	ELFO-FM, ELFO-PM	off	off	off	off	off	FLT-Frq	ChoSend, Volume
84(F04)	Stereo Brs	Br	Hall 1	Chorus 1	Thru	Thru	ELFO-FM, ELFO-PM	off	off	off	off	off	FLT-Frq	ChoSend, Volume
85(F05)	Trumpet	Br	Hall 1	Ensemble	Thru	Delay LCR	ELFO-PM, ELFO-FM	off	off	off	off	off	RevSend	ChoSend, FLT-Rez
86(F06)	Mute Trpt	Br	Hall 1	Chorus 1	3band EQ	Thru	ELFO-PM	ELFO-AM	off	off	off	off	RevSend	HPF-Frq
87(F07)	Tenor Sax	Rd	Hall 1	Chorus 1	3band EQ	Thru	ELFO-PM, ELFO-AM	off	off	off	off	off	FLT-Frq	ChoSend
88(F08)	Alto Sax	Rd	Hall 1	Chorus 1	3band EQ	Thru	ELFO-PM, ELFO-AM	off	off	off	off	off	FLT-Frq	ChoSend
89(F09)	Bari Sax	Rd	Hall 1	Chorus 1	3band EQ	Thru	ELFO-PM, ELFO-FM	off	off	off	off	off	FLT-Frq	ChoSend
90(F10)	Soprano	Rd	Hall 1	Delay LR	3band EQ	Thru	ELFO-PM	off	off	off	off	off	RevSend	ChoSend
91(F11)	ObrBrass	Br	Hall 1	Chorus 4	3band EQ	Chorus 4	CLFO-D1	off	off	off	off	off	RevSend	FLT-Frq, FLT-Rez
92(F12)	PowerSynth	Br	Hall 1	Chorus 1	3band EQ	Harmonic Enhancer	CLFO-D1	off	off	off	off	off	InsL prm3	RevSend
93(F13)	Synth Horn	Br	Hall 2	Chorus 1	Thru	Tempo Cross Delay	FLT-Frq, ChoSend, RevSend	off	off	off	off	off	InsL prm10	FLT-Rez
94(F14)	M Brass	Br	Hall 1	Delay LR	Thru	Thru	ELFO-PM	off	off	off	off	off	FLT-Frq, FLT-Rez	PEG-Dpt, PEG-Atk
95(F15)	Moon AT	Br	Hall 1	Chorus 1	3band EQ	Harmonic Enhancer	CLFO-D1	off	FLT-Frq, Volume	off	off	off	PCH-Crs	RevSend
96(F16)	SquishBrs	Br	Hall 1	Chorus 1	Thru	Thru	ELFO-PM	off	off	off	off	off	FLT-Rez	RevSend, ChoSend
97(G01)	Ooh Choir	Vo	Hall 2	Delay LR	Exciter	3Band EQ	CLFO-D1	off	off	off	off	off	AEG-Atk, AEG-Rel	RevSend, ChoSend
98(G02)	Ahh Choir	Vo	Hall 2	Delay LR	3band EQ	Talking Modulator	CLFO-D1	off	off	off	off	off	AEG-Atk, AEG-Rel	RevSend, ChoSend
99(G03)	Panmonks	Vo	Plate	Delay LR	Tremolo	Ensemble Detune	InsS prm2	off	off	off	off	off	AEG-Rel	RevSend, ChoSend
100(G04)	Pad Ooh	En	Hall 1	Ensemble	Chorus 1	Thru	InsS prm10, ChoSend	off	off	off	off	off	FLT-Frq	AEG-Atk, AEG-Rel
101(G05)	Soft Pad	Pd	Hall 1	Chorus 1	Thru	V-Flanger	InsL prm14	off	off	off	off	off	ELM-Lvl	ChoSend
102(G06)	FatSweep	Pd	Hall 2	Symphonic	Chorus 4	Cross Delay	ELFO-PM	off	off	off	off	off	ChoSend	InsL prm10
103(G07)	Cumulus	Pd	Hall 1	Delay LR	Celeste 3	Harmonic Enhancer	ELFO-FM	off	off	off	off	off	RevSend	ChoSend
104(G08)	Big Wing	Pd	Stage 1	Ensemble	Celeste 4	Harmonic Enhancer	ELM-Lvl	off	off	off	off	off	InsL prm3	RevSend
105(G09)	Slide in	Pd	Hall 1	Chorus 1	Thru	Thru	ELFO-PM	off	off	off	off	off	PEG-Atk	ChoSend
106(G10)	BPFx	Pd	Hall 2	Ensemble	Chorus 4	Cross Delay	CLFO-D1, ELM-Lvl	off	CLFO-D1	off	off	off	FEG-Dpt	InsL prm10
107(G11)	DigiSweep	Pd	Hall 2	Chorus 5	Compressor	Tempo Cross Delay	FLT-Frq, FEG-Dpt, RevSend	off	off	off	off	off	ChoSend	RevSend
108(G12)	JM Pad	Pd	Hall 2	Chorus 4	Thru	Phaser 2	ELFO-PM, InsL prm1, InsL prm2	off	off	off	off	off	FLT-Frq	FLT-Rez
109(G13)	Vermillion	Pd	Hall 1	Tempo Delay2	Thru	Pitch Change 1	ELFO-PM	off	off	off	off	off	FLT-Frq	ChoSend, RevSend
110(G14)	Magenta	Pd	Hall 1	Chorus 1	Flanger 1	Delay LCR	ELFO-PM, FLT-Frq	off	ELFO-PM	off	off	off	FLT-Frq	ChoSend, ChoSend
111(G15)	Liquito	Sc	Hall 1	Chorus 1	Compressor	V-Flanger	AEG-Rel, FLT-Frq, AEG-D1	off	off	off	off	off	FLT-Rez	ChoSend, RevSend
112(G16)	Shadow	Fx	Hall 2	Flanger 1	Celeste 4	Jump	InsL prm2, ChoSend	off	off	off	off	off	FLT-Frq	InsL prm9
113(H01)	Vibes	Cp	Hall 1	Celeste 2	Thru	3Band EQ	ChoSend	off	off	off	off	off	ELFO-AM	ELFOSpd
114(H02)	Marimba	Cp	Hall 1	Celeste 2	Thru	Thru	ELFO-AM	off	off	off	off	off	FLT-Frq, FLT-Rez	RevSend, ChoSend
115(H03)	Gamelan	Cp	Hall 1	Symphonic	Thru	Thru	ChoSend	off	off	off	off	off	FLT-Frq	AEG-Atk, AEG-Rel
116(H04)	Xylo	Cp	Hall 1	Celeste 2	Thru	Thru	ELFO-FM	off	off	off	off	off	RevSend	ChoSend
117(H05)	Glocken	Cp	Hall 2	Celeste 2	Thru	Thru	ChoSend	off	off	off	off	off	RevSend	ELFO-PM
118(H06)	Crotales	Cp	Hall 1	Celeste 2	Thru	Thru	FLT-Frq	off	off	off	off	off	FLT-Frq	RevSend
119(H07)	Timpani	Pc	Hall 1	Celeste 2	Thru	Thru	ELFO-AM	off	off	off	off	off	AEG-Atk	FLT-Frq
120(H08)	SteelDrum	Cp	Hall 1	Celeste 2	Thru	Thru	ELFO-FM, ChoSend	off	off	off	off	off	AEG-Rel	RevSend
121(H09)	Sitar	Et	Hall 1	Flanger 1	3band EQ	Ensemble Detune	ELFO-PM	off	off	off	off	off	ChoSend	RevSend
122(H10)	BrthFlute	Pi	Hall 1	Chorus 1	Thru	Thru	CLFO-D1, CLFO-D2	off	off	off	off	off	FLT-Frq	ELM-Lvl
123(H11)	Pan Flute	Pi	Hall 1	Chorus 1	Thru	Thru	ELFO-AM, ELFO-FM	off	off	off	off	off	FLT-Frq, FLT-Rez	AEG-Atk
124(H12)	Accordion	Or	Hall 1	Ensemble	Thru	Thru	ChoSend	off	off	off	off	off	HPF-Frq	FLT-Frq
125(H13)	Monica	Rd	Stage 1	Ensemble	AMP Simulator	Touch WAH	ELFO-PM	FLT-Frq	ELFO-PM	off	off	off	ChoSend	RevSend
126(H14)	BluesHarp	Rd	Stage 2	Chorus 1	Touch Wah	V-Distortion	ELFO-AM, CLFO-D1, ELFO-PM	FLT-Frq	off	off	off	off	InsL prm1	RevSend
127(H15)	Amandia	Co	Stage 1	Delay LR	2band EQ	Celeste 4	ELFO-PM	off	ELFO-PM	off	off	off	RevSend	ChoSend
128(H16)	AnalogSplit	Co	Hall 1	Chorus 1	Phaser	Tempo Delay 2	ELFO-PM	off	ELFO-PM	off	off	off	InsS prm1	InsL prm10

Preset 2 (MSB=63, LSB=1)

No.	Voice Name	Category	Reverb Type	Chorus Type	Insertion1 Type	Insertion2 Type	MW	PB	AT	FC	BC	FS	Kn1	Kn2
1(A01)	1001 Sub	Ba	Stage 2	Ensemble	Thru	Echo	ChoSend, ELM-Lvl	off	off	off	off	off	FLT-Frq, FEG-D1	InsL_prm10
2(A02)	Trancy	Ba	Hall 1	Chorus 4	Thru	Delay LR	ChoSend, ELM-Lvl	off	off	off	off	off	FEG-Atk	InsL_prm10
3(A03)	Velo	Ba	Stage 2	Chorus 1	Thru	Auto WAH	InsL_prm10, RevSend	off	off	off	off	off	FEG-Atk	ChoSend
4(A04)	Wonk	Ba	Hall 1	Ensemble	3band EQ	Thru	ELFO-PM	off	off	off	off	off	FLT-Rez	RevSend, ChoSend
5(A05)	Mini 1	Ba	Room 1	Chorus 1	3band EQ	Pitch Change 1	ELFO-PM	off	off	off	off	off	InsL_prm10	RevSend
6(A06)	Mini 2	Ba	Room 1	Chorus 1	3band EQ	Pitch Change 1	ELFO-PM	off	off	off	off	off	InsL_prm10	RevSend
7(A07)	D-sub	Ba	Hall 1	Flanger 1	Thru	Thru	ELFO-PM	off	off	off	off	off	FLT-Frq	ChoSend
8(A08)	Lately	Ba	Room 3	Control Delay1	Compressor	AMP Simulator	ELFO-PM	off	off	off	off	off	InsL_prm10	ELFOSpd
9(A09)	Dark	Ba	Stage 2	Chorus 1	Thru	Thru	FLT-Frq	off	off	off	off	off	FEG-Atk, FEG-D1	ChoSend, ELM-Lvl
10(A10)	Moonbass	Ba	Hall 1	Flanger 1	Thru	Thru	ELFO-PM	off	off	off	off	off	FLT-Frq	ChoSend
11(A11)	Snoop Bs	Ba	Hall 1	Phaser	3band EQ	Thru	ELFO-PM	off	off	off	off	off	FLT-Frq	ChoSend, RevSend
12(A12)	LoTic Bass	Ba	Room 1	Chorus 1	Thru	Chorus 1	ELFO-PM, Volume	off	ELFO-PM	off	off	off	AEG-Atk, AEG-Rel	ChoSend
13(A13)	Taurus	Ba	Hall 1	Flanger 1	Thru	Thru	ELFO-PM	off	off	off	off	off	FLT-Frq, FLT-Rez	ChoSend
14(A14)	Fuzzline	Ba	Hall 1	Phaser	Distortion	Delay LR	ChoSend, ELM-Lvl	off	off	off	off	off	InsS_prm10, ELM-Lvl	InsL_prm10
15(A15)	Deep One	Ba	Hall 1	Chorus 1	Thru	Thru	ELFO-PM	off	off	off	off	off	FLT-Frq	FLT-Rez
16(A16)	Squbase	Ba	Hall 1	Tempo Cross Delay	Flanger 1	Thru	ELFO-PM, ELM-Lvl	off	off	off	off	off	InsS_prm10, ChoSend	InsS_prm3
17(B01)	Portachrd	Sc	Hall 1	Chorus 4	Thru	Delay LR	FLT-Rez, FLT-Frq, ChoSend	off	off	off	off	off	FEG-Atk	ChoSend
18(B02)	Thin man	Sc	Hall 2	Ensemble	Compressor	Cross Delay	FLT-Frq	off	off	off	off	off	AEG-Atk, AEG-Rel	ChoSend, ELM-Lvl
19(B03)	PopularSyn	Sc	Hall 1	Chorus 1	Auto Wah	Cross Delay	InsS_prm2	off	off	off	off	off	ChoSend	InsL_prm10
20(B04)	Straight	Sc	Hall 1	Ensemble	Celeste 4	Cross Delay	ELFO-PM	off	off	off	off	off	FLT-Rez, InsS_prm1	AEG-Rel, FLT-Rez
21(B05)	Poly	Sc	Hall 1	Ensemble	Auto Wah	Delay LR	ELFO-PM	off	off	off	off	off	FLT-Frq, FEG-Dpt	InsS_prm9
22(B06)	Zap Comp	Sc	Hall 1	Chorus 1	Touch Wah	Cross Delay	ELFO-PM	off	off	off	off	off	FLT-Rez	RevSend, ChoSend
23(B07)	AnaTonk	Sc	Hall 1	Chorus 1	Thru	Thru	ELFO-PM	off	off	off	off	off	FEG-D1, FEG-D2	ChoSend
24(B08)	Insomnia	Sc	Hall 1	Tempo Phaser	Compressor	Thru	FLT-Frq	off	off	off	off	off	ELM-Lvl	RevSend
25(B09)	Q Hit	Sc	White Room	Control Delay1	Exciter	Gate Reverb	ELFO-PM	off	off	off	off	off	ELM-Lvl, FLT-Frq	RevSend
26(B10)	BPF1	Sc	Hall 1	Chorus 1	Thru	Thru	CLFO-D1	off	off	off	off	off	FLT-Frq, FLT-Frq	FEG-Atk
27(B11)	T-Eight	Sc	Hall 1	Delay LR	Chorus 1	Compressor	ELFO-PM, CLFOSpd, InsS_prm10	off	off	off	off	off	FLT-Frq, FEG-Dpt	FEG-Atk
28(B12)	L7 octs	Sc	Hall 1	Celeste 3	Thru	Thru	ELFO-PM	off	off	off	off	off	FLT-Frq	ChoSend, Volume
29(B13)	NoizRezz	Sc	Hall 1	Chorus 2	Thru	Tempo Cross Delay	ELFO-PM	off	off	off	off	off	InsL_prm10, ChoSend	RevSend
30(B14)	GX	Sc	Hall 1	Celeste 4	Thru	Thru	CLFO-D1	off	off	off	off	off	FLT-Frq	ChoSend, RevSend
31(B15)	Noise Harp	Sc	Room 3	Celeste 2	Thru	Hall 1	ELFO-PM	off	off	off	off	off	ChoSend	RevSend
32(B16)	Syntax	Ld	Hall 1	Ensemble	Flanger 3	Delay LCR	FLT-Frq	off	off	off	off	off	InsS_prm10	ChoSend
33(C01)	Tri Solo	Ld	Hall 1	Delay LR	3band EQ	Thru	ELFO-PM	off	off	off	off	off	FLT-Frq	ChoSend, Volume, RevSend
34(C02)	Smooth Saw	Ld	Hall 1	Delay LR	Thru	Thru	ELFO-PM	off	off	off	off	off	FLT-Frq	ChoSend, Volume, RevSend
35(C03)	Frontline	Ld	Hall 1	Ensemble	Distortion	Cross Delay	ChoSend, ELM-Lvl	off	off	off	off	off	PCH-Fin	ChoSend
36(C04)	Lucky	Ld	Hall 1	Chorus 3	Thru	Thru	ELFO-PM	off	off	off	off	off	FLT-Frq	ChoSend, Volume
37(C05)	Sneaky	Ld	Hall 1	Chorus 1	Thru	Thru	ELFO-PM	off	off	off	off	off	FEG-Dpt	FLT-Rez
38(C06)	Rap Lead 1	Ld	Hall 1	Chorus 1	Thru	Thru	ELFO-PM	off	off	off	off	off	FLT-Frq	FLT-Rez
39(C07)	Rap Lead 2	Ld	Hall 1	Chorus 1	Thru	Thru	ELFO-PM	off	off	off	off	off	FLT-Frq	FLT-Rez
40(C08)	Rap Lead 3	Ld	Hall 1	Chorus 1	Thru	Thru	ELFO-PM	off	off	off	off	off	FLT-Frq	FLT-Rez
41(C09)	PhazFilter	Ld	Hall 1	Tempo Phaser	Chorus 1	Ensemble Detune	ELFO-PM	off	off	off	off	off	InsS_prm10, InsL_prm10, InsS_prm2	PEG-Dpt
42(C10)	SpaceWhirl	Ld	Tunnel	Tempo Delay2	Compressor	Tempo Phaser	InsL_prm10, FLT-Frq, AEG-Rel	off	off	off	off	off	RevSend	ChoSend
43(C11)	X-File	Ld	Stage 1	Delay LR	Thru	V-Flanger	ELFO-PM	off	off	off	off	off	PorTime	RevSend
44(C12)	BreathSaw	Ld	Hall 1	Delay LR	2band EQ	Ambience	CLFO-D1, CLFO-D2	off	off	off	off	off	ELM-Lvl	RevSend
45(C13)	1 is more	Ld	Hall 1	Ensemble	Thru	Delay LR	ELFO-PM	off	off	off	off	off	ChoSend	AEG-Atk
46(C14)	Mini Pulse	Ld	Hall 2	Chorus 2	Compressor	Tempo Cross Delay	ELFO-PM	off	off	off	off	off	ChoSend	RevSend, InsL_prm10
47(C15)	Syntrump	Ld	Hall 1	Tempo Delay1	Thru	Thru	ELFO-PM	off	off	off	off	off	FLT-Frq	ChoSend
48(C16)	Eagle	Ld	Hall 1	Tempo Delay1	Thru	Thru	ELFO-PM	off	off	off	off	off	FLT-Frq	ChoSend
49(D01)	Oberweich	Pd	Hall 1	Chorus 1	Thru	Thru	CLFO-D1	off	off	off	off	off	ChoSend	RevSend
50(D02)	5thBreath	Pd	Hall 2	Ensemble	Exciter	Cross Delay	CLFO-D1	off	off	off	off	off	FLT-Frq, FLT-Rez	InsL_prm10
51(D03)	Rain Pad	Pd	Hall 1	Chorus 1	Thru	Thru	ChoSend, Volume	off	off	off	off	off	FLT-Rez	ELM-Lvl, ELM-Lvl
52(D04)	Vortex	Pd	White Room	Chorus 1	Flanger 3	Thru	ELFO-PM, ELFO-FM	off	off	off	off	off	PEG-Dpt	InsS_prm1
53(D05)	Sprinkler	Pd	Hall 1	Chorus 1	Thru	V-Flanger	PCH-Crs, Volume	off	off	off	off	off	ELM-Lvl	AEG-Atk, AEG-Rel
54(D06)	Astronaut	Pd	Stage 1	Celeste 4	Phaser	Ambience	FLT-Frq	off	off	off	off	off	ChoSend	RevSend, InsL_prm10
55(D07)	BrassyPad	Pd	Hall 1	Delay LR	Chorus 1	V-Flanger	ELM-Lvl	off	off	off	off	off	FLT-Frq	InsL_prm14, InsL_prm2
56(D08)	Sine Pad	Pd	Hall 2	Chorus 1	Thru	Symphonic	CLFO-D1	off	off	off	off	off	ChoSend	RevSend
57(D09)	Big Syn	St	Hall 2	Chorus 5	Exciter	Cross Delay	FLT-Frq, FLT-Rez	off	off	off	off	off	ELM-Lvl	ELM-Lvl
58(D10)	Berlin	Sc	Hall 2	Flanger 3	Chorus 4	Cross Delay	ChoSend, ELM-Lvl, FLT-Frq	off	off	off	off	off	FLT-Frq	PEG-Dpt
59(D11)	Filtopia	Sc	Hall 1	Chorus 1	Compressor	Hall 2	ELM-Lvl, ChoSend, FLT-Frq	off	off	off	off	off	FEG-Atk	FLT-Frq
60(D12)	Poppy Vox	Sc	Hall 1	Symphonic	Exciter	Hall 1	ELFO-PM	FLT-Frq	off	off	off	off	ChoSend	RevSend
61(D13)	Arabesque	Sc	Hall 1	Chorus 1	Compressor	Hall 2	FLT-Frq, ELM-Lvl, ELM-Pan	off	off	off	off	off	InsL_prm13	AEG-D1
62(D14)	Crecendar	Sc	Hall 1	Chorus 1	Flanger 1	Delay LCR	ELFO-PM, FLT-Frq	off	ELFO-PM, InsS_prm1	off	off	off	FLT-Frq	FLT-Rez
63(D15)	Soft Dream	Co	Hall 2	Symphonic	Celeste 4	Thru	CLFO-D1, ChoSend	off	off	off	off	off	FLT-Frq	ChoSend
64(D16)	ChimzArt	Co	Hall 1	Chorus 1	Compressor	Hall 2	ELM-Lvl, ELM-Lvl, Volume	off	off	off	off	off	ChoSend	ELM-Pan

No.	Voice Name	Category	Reverb Type	Chorus Type	Insertion1 Type	Insertion2 Type	MW	PB	AT	FC	BC	FS	Kn1	Kn2
65(E01)	Seal	Sq	Hall 2	Tempo Cross Delay	Chorus 4	Ensemble Detune	FLT-Rez, ELM-Lvl	off	off	off	off	off	ELM-Lvl	ChoSend
66(E02)	Shine Seq	Sq	Hall 1	Tempo Cross Delay	Chorus 1	Ensemble Detune	FLT-Rez	off	off	off	off	off	FLT-Frq, ELM-Lvl, CLFO-D1	FLT-Rez
67(E03)	Kickwheel	Sq	Hall 1	Tempo Flanger	Distortion	Delay LR	ELM-Lvl, ChoSend	off	off	off	off	off	InsL_prm10, ELM-Lvl	HPF-Frq
68(E04)	Supersnap	Sq	Hall 1	Phaser	Compressor	Delay LR	ELM-Lvl	off	off	off	off	off	ELM-Lvl	ChoSend, InsL_prm10
69(E05)	Opener	Sq	Hall 1	Tempo Cross Delay	Chorus 4	Tempo Phaser	FLT-Frq, InsL_prm10	off	off	off	off	off	FEG-Atk	ChoSend, InsL_prm10
70(E06)	Rosy	Sq	Hall 1	Ensemble	Thru	Delay LR	FLT-Frq	off	off	off	off	off	FEG-Atk	InsL_prm10
71(E07)	LAizer	Sq	Hall 2	Chorus 2	Compressor	Tempo Delay 2	ELM-Lvl, FLT-Frq, ChoSend	off	off	off	off	off	ELM-Dly	InsL_prm10
72(E08)	2 Friends	Sq	Hall 2	Tempo Delay2	Phaser	Hall 2	ELM-Lvl, ChoSend, AEG-D1	off	off	off	off	off	InsS_prm10	FLT-Frq
73(E09)	Synfonic	Sq	Hall 2	Chorus 1	Thru	Tempo Cross Delay	InsL_prm10, ChoSend, FLT-Frq	off	off	off	off	off	InsL_prm10	RevSend
74(E10)	Hard road	Sq	Hall 1	Flanger 2	AMP Simulator	Delay LR	FEG-Atk, FLT-Frq	off	off	off	off	off	FEG-Atk, FLT-Frq	InsS_prm6
75(E11)	Quartz	Sq	Tunnel	Control Delay1	Flanger 3	Voice Cancelar	ELM-Lvl	off	off	off	off	off	InsL_prm11	InsL_prm12
76(E12)	Atom	Dr	White Room	Phaser	Touch Wah	Talking Modulator	ELFOSpd	off	off	off	off	off	InsL_prm1	RevSend
77(E13)	Chordal	Sq	Hall 1	Chorus 4	Thru	Delay LR	AEG-D2, FLT-Frq	off	off	off	off	off	PEG-Dpt	InsL_prm10, ChoSend
78(E14)	Orgmatic	Sq	Hall 2	Phaser	Compressor	Tempo Delay 2	InsL_prm10, ELM-Lvl, ELM-Lvl	off	off	off	off	off	FLT-Frq	RevSend
79(E15)	Ana Plus	Sq	Hall 1	Tempo Cross Delay	Compressor	Ensemble Detune	ELM-Lvl, InsL_prm10	off	off	off	off	off	ELM-Lvl	InsS_prm3, InsS_prm5
80(E16)	Frequencyz	Se	off	Tempo Cross Delay	Thru	Gate Reverb	ChoSend	off	off	off	off	off	FLT-Frq, FLT-Frq	InsL_prm10
81(F01)	Psycho	Se	Hall 1	Chorus 1	Thru	Harmonic Enhancer	ELFO-PM	off	FLT-Rez	off	off	off	RevSend	PCH-Crs
82(F02)	S - E	Se	Stage 2	Chorus 1	Flanger 3	Tempo Cross Delay	ELFO-PM	off	off	off	off	off	InsS_prm3	InsS_prm1
83(F03)	Voltage	Se	Hall 2	Flanger 2	AMP Simulator	Auto Synth	InsL_prm13	off	off	off	off	off	InsL_prm1	ChoSend, ELM-Lvl
84(F04)	Ectoplasm	Se	Hall 1	Tempo Cross Delay	Chorus 2	Symphonic	InsL_prm1	off	off	off	off	off	FLT-Frq	ELFO-AM
85(F05)	Millemium	Se	Hall 1	Flanger 1	Exciter	Hall 2	ELFO-PM, ELFO-FM	off	off	off	off	off	FLT-Frq	ELFO-PM
86(F06)	Noire	Se	Plate	Delay LR	Flanger 3	Ensemble Detune	ELFO-PM	off	off	off	off	off	InsS_prm3, InsS_prm2	PCH-Crs
87(F07)	Falling	Se	Hall 1	Chorus 1	Thru	Hall 1	ChoSend, Volume	off	off	off	off	off	FLT-Rez	ELM-Lvl, ELM-Lvl
88(F08)	Topnotched	Se	Hall 1	Tempo Delay2	Thru	Thru	ELFO-AM, Volume	off	off	off	off	off	ELFOSpd	FLT-Frq, FLT-Frq
89(F09)	Drumotize	Se	Hall 1	Chorus 1	3band EQ	AMP Simulator	ELFO-PM	off	off	off	off	off	FLT-Frq	FLT-Rez
90(F10)	Creature	Se	Hall 1	Control Delay1	Thru	Pitch Change 2	FLT-Frq	off	off	off	off	off	ChoSend	RevSend
91(F11)	Develop	Se	Basement	Phaser	Phaser	Pitch Change 2	InsS_prm1	off	off	off	off	off	ELM-Lvl	RevSend
92(F12)	Twilight	Se	Canyon	Tempo Cross Delay	Celeste 4	Pitch Change 1	ELFO-AM, ELFOSpd	off	off	off	off	off	ELFOSpd, CLFOSpd	PCH-Crs
93(F13)	RisingHigh	Fx	Hall 1	Chorus 1	Thru	Thru	ELFO-AM	off	off	off	off	off	RevSend	ChoSend
94(F14)	90th Jimi	Fx	Hall 1	Flanger 2	AMP Simulator	Jump	ChoSend, FLT-Frq	off	off	off	off	off	FEG-Atk, FLT-Frq	InsS_prm6
95(F15)	Dew-drop	Fx	Stage 1	Tempo Delay1	Phaser	Pitch Change 2	InsS_prm1	off	off	off	off	off	ELM-Lvl	InsL_prm10, ChoSend
96(F16)	SpaceTrain	Fx	Hall 1	Ensemble	Phaser	Ensemble Detune	ELFOSpd	off	off	off	off	off	ChoSend	RevSend
97(G01)	Brown Eyes	Fx	Plate	Symphonic	Exciter	Auto Synth	InsL_prm10, FEG-Atk	off	off	off	off	off	InsL_prm12	InsL_prm3
98(G02)	Glacier	Fx	Stage 1	Tempo Cross Delay	Celeste 4	Harmonic Enhancer	InsS_prm1	off	off	off	off	off	ELM-Lvl	ChoSend
99(G03)	Sahara	Fx	Hall 1	Chorus 1	Flanger 1	Hall 1	FLT-Frq	off	off	off	off	off	AEG-Atk	ChoSend
100(G04)	Sunnydaze	Fx	Stage 1	Tempo Cross Delay	Chorus 1	Chorus 1	ELFO-AM, ELM-Lvl	off	off	off	off	off	InsL_prm10, InsS_prm10	ELFOSpd
101(G05)	Starlight	Fx	Hall 1	Chorus 1	Thru	Pitch Change 2	ELM-Lvl	off	off	off	off	off	FLT-Frq	ChoSend
102(G06)	Roxy	Fx	Hall 2	Ensemble	Chorus 4	Thru	CLFO-D1, CLFO-D2, ELM-Lvl	off	off	off	off	off	FEG-Dpt	CLFOSpd
103(G07)	Bel Air	Fx	Hall 2	Chorus 4	Exciter	Flanger 3	InsS_prm1, FLT-Rez, FLT-Frq	off	off	off	off	off	InsL_prm10	ChoSend
104(G08)	Answers	Fx	Hall 1	Chorus 1	Thru	Delay LR	Volume	off	off	off	off	off	ELM-Dly	RevSend
105(G09)	Bassline	Ba	Hall 1	Flanger 2	Distortion	Delay LCR	ChoSend, ELM-Lvl	off	off	off	off	off	FEG-Atk	InsS_prm10, InsL_prm10
106(G10)	Boom Bass	Ba	Room 3	Symphonic	Compressor	Voice Cancelar	PEG-Atk	off	off	off	off	off	ELFO-PM	ELFOSpd
107(G11)	Drone	Ba	Hall 2	Chorus 2	Compressor	Tempo Delay 2	FLT-Frq, CLFOSpd, FLT-Rez	off	off	off	off	off	InsL_prm10, ChoSend	RevSend
108(G12)	Sweepy	Ba	Hall 2	Chorus 4	Thru	Delay LR	FLT-Frq, ChoSend	off	off	off	off	off	FEG-Atk	InsL_prm10, ChoSend
109(G13)	Super DX	Ba	Room 1	Chorus 1	Exciter	Ensemble Detune	ELFO-PM	off	off	off	off	off	FLT-Frq	FLT-Rez
110(G14)	GangstaM	Ba	Room 1	Symphonic	Compressor	Tempo Cross Delay	FLT-Frq, RevSend	off	off	off	off	off	ChoSend, Volume	RevSend
111(G15)	FM Perko	Ba	Room 1	Chorus 2	Compressor	V-Flanger	ChoSend, ELM-Lvl, Volume	off	off	off	off	off	RevSend	FLT-Frq
112(G16)	DX100	Ba	Room 3	Chorus 1	Thru	Thru	FLT-Frq	off	off	off	off	off	ELFO-FM	RevSend
113(H01)	BriteGrand	Pf	Hall 1	Chorus 1	3band EQ	Flanger 3	InsL_prm10	off	off	off	off	off	ChoSend	RevSend
114(H02)	Slamming	Pf	Room 3	Tempo Delay2	Compressor	Voice Cancelar	AEG-D1	off	off	off	off	off	InsL_prm11	InsL_prm12
115(H03)	Danzze	Pf	Room 1	Control Delay1	Overdrive	Thru	ChoSend, RevSend	off	off	off	off	off	ELM-Pan	FLT-Frq
116(H04)	House	Pf	Room 2	Control Delay2	Compressor	Ambience	RevSend	off	off	off	off	off	InsL_prm10	ChoSend, FLT-Frq
117(H05)	M25	Pf	Hall 1	Tempo Delay1	Exciter	Pitch Change 1	InsL_prm10	off	off	off	off	off	PCH-Fin	ChoSend
118(H06)	AcidFly	Pf	Stage 1	Delay LR	AMP Simulator	Digital Scratch	ChoSend, RevSend	off	off	off	off	off	InsL_prm5	InsL_prm11
119(H07)	Nite Roadz	Pf	Hall 2	Chorus 1	Compressor	Celeste 4	InsL_prm1, InsL_prm2	off	off	off	off	off	InsL_prm10	RevSend
120(H08)	GS Brassy	Sc	Hall 1	Chorus 1	Chorus 1	Thru	ELFO-PM	off	off	off	off	off	FEG-D2, FEG-D1, AEG-D2	RevSend
121(H09)	Grand Pad	Co	Hall 1	Chorus 1	3band EQ	Tempo Cross Delay	AEG-Atk	off	off	off	off	off	FLT-Frq	InsL_prm10
122(H10)	Ibiza	Co	Hall 1	Tempo Delay1	Compressor	Celeste 4	FLT-Frq	off	off	off	off	off	RevSend	ChoSend
123(H11)	Melpiano	Co	Plate	Chorus 1	Thru	Symphonic	ELM-Lvl	off	off	off	off	off	ELM-Lvl	RevSend
124(H12)	HonkyTonk	Pf	Room 1	Chorus 1	Thru	Pitch Change 1	ChoSend	off	off	off	off	off	FLT-Frq	RevSend
125(H13)	For Ballad	Pf	Hall 1	Delay LR	Thru	Chorus 4	ELM-Lvl	off	off	off	off	off	ChoSend	RevSend
126(H14)	ShineHarmo	Pf	Hall 1	Chorus 1	3band EQ	Chorus 5	ChoSend, Volume	off	off	off	off	off	PCH-Crs	RevSend
127(H15)	TripleDark	Pf	Hall 1	Chorus 1	3band EQ	Thru	ChoSend	off	off	off	off	off	FLT-Frq	RevSend
128(H16)	StageBrite	Pf	Hall 1	Chorus 1	Thru	Harmonic Enhancer	ChoSend	off	off	off	off	off	FLT-Frq	RevSend

Internal (MSB=63, LSB=8)

No.	Voice Name	Category	Reverb Type	Chorus Type	Insertion1 Type	Insertion2 Type	MW	PB	AT	FC	BC	FS	Kn1	Kn2
1(A01)	Hybrid	Pf	Hall 1	Chorus 1	Thru	Thru	ChoSend	off	off	off	off	off	FLT-Frq, FLT-Rez	RevSend
2(A02)	DarkGrand2	Pf	Room 2	Chorus 1	3band EQ	Thru	ChoSend	off	off	off	off	off	FLT-Frq	RevSend
3(A03)	BrtStereo	Pf	Hall 1	Celeste 1	3band EQ	Phaser 2	InsL_prm10	off	off	off	off	off	ChoSend	RevSend
4(A04)	HonkyTnk2	Pf	Room 3	Chorus 1	Thru	Thru	ChoSend	off	off	off	off	off	FLT-Frq	RevSend
5(A05)	Differenc2	Pf	Hall 1	Chorus 1	3band EQ	Harmonic Enhancer	InsL_prm3	off	off	off	off	off	ChoSend	RevSend
6(A06)	Piano/Ep2	Pf	Hall 1	Chorus 1	Chorus 1	Thru	FLT-Frq, ELM-Lvl	off	off	off	off	off	ELM-Lvl, ELM-Lvl	InsS_prm10
7(A07)	Pno/Oo/Str	Co	Hall 1	Chorus 1	Chorus 2	Thru	ELM-Lvl	off	off	off	off	off	ELM-Lvl	ChoSend
8(A08)	Grand Pad2	Co	Hall 1	Delay LR	Chorus 1	Thru	ELM-Lvl	off	off	off	off	off	FLT-Frq	ChoSend
9(A09)	Phase CP	Pf	Room 1	Chorus 1	Thru	Phaser 2	FLT-Frq	off	off	off	off	off	InsL_prm10, InsL_prm4, InsL_prm2	RevSend
10(A10)	CP Layer	Pf	Room 2	Ensemble	Thru	Thru	RevSend	off	off	off	off	off	FLT-Frq	ChoSend
11(A11)	WurlI Amp	Pf	Room 1	Celeste 1	Overdrive	Tremolo	InsL_prm2, Volume	off	off	off	off	off	FLT-Frq	InsS_prm1, RevSend
12(A12)	SunShine	Pf	Room 2	Chorus 1	Auto Pan	Compressor	InsS_prm1	off	off	off	off	off	InsS_prm2	RevSend
13(A13)	Phaser EP	Pf	Hall 2	Flanger 1	Flanger 1	Phaser 1	ELFO-PM	off	off	off	off	off	InsL_prm4, InsL_prm1	RevSend
14(A14)	RB Roadz	Pf	Hall 1	Chorus 1	Compressor	Celeste 3	InsL_prm1	off	off	off	off	off	InsS_prm4, InsS_prm3	RevSend
15(A15)	BasicRoad2	Pf	Hall 1	Chorus 1	3band EQ	Auto Pan	InsL_prm1	off	off	off	off	off	InsL_prm2	RevSend, ChoSend
16(A16)	Early70Rhd	Pf	Stage 1	Chorus 1	Tremolo	V-Distortion	InsS_prm2	off	off	off	off	off	AEG-D1	RevSend
17(B01)	Doogie	Pf	Hall 1	Chorus 1	Thru	Thru	CLFO-D1	off	off	off	off	off	FLT-Frq	ChoSend, RevSend
18(B02)	RT Roadz	Pf	Stage 1	Chorus 1	Auto Pan	Phaser 1	InsS_prm1, InsL_prm1	off	off	off	off	off	InsS_prm2	RevSend
19(B03)	Dyno Pad	Co	Hall 1	Chorus 1	Chorus 1	Thru	ELM-Lvl	off	off	off	off	off	FLT-Frq	ChoSend, RevSend
20(B04)	Roadz Pad	Co	Stage 2	Chorus 1	Auto Pan	Chorus 3	InsS_prm2	off	off	off	off	off	FLT-Frq	ChoSend, Volume
21(B05)	NiteBallad	Pf	Hall 2	Chorus 1	Compressor	Celeste 4	InsL_prm1, InsL_prm2	off	off	off	off	off	InsL_prm10	RevSend
22(B06)	DXTinyVel	Pf	Hall 1	Symphonic	Celeste 4	Harmonic Enhancer	ELFO-AM	off	off	off	off	off	InsL_prm3	RevSend
23(B07)	DX Hard	Pf	Hall 1	Chorus 1	Exciter	Symphonic	ELFO-AM	off	off	off	off	off	InsS_prm3	RevSend
24(B08)	Superstit	Pf	Room 3	Chorus 2	AMP Simulator	Phaser 2	InsL_prm10	off	off	off	off	off	AEG-D1, AEG-D2	ChoSend
25(B09)	Puls Clav	Sc	Hall 1	Phaser	Thru	Thru	ELFO-PM	off	off	off	off	off	FLT-Rez	AEG-D1, AEG-D2
26(B10)	Handbel	Cp	Hall 1	Chorus 1	Thru	Thru	ELFO-AM	off	off	off	off	off	FLT-Frq	ChoSend, RevSend
27(B11)	Estrn Bel1	Cp	Hall 1	Celeste 1	Chorus 1	Thru	ChoSend	off	off	off	off	off	FLT-Frq	PCH-Crs
28(B12)	Tiny bell	Cp	Hall 1	Chorus 1	Chorus 1	Thru	ChoSend	off	off	off	off	off	FLT-Frq	AEG-Atk
29(B13)	Argent	Or	Room 1	Chorus 1	Overdrive	Rotary Speaker 1	InsL_prm1	off	off	off	off	off	InsL_prm9	InsL_prm1
30(B14)	Como Va	Or	Room 1	Chorus 1	Overdrive	Rotary Speaker 1	InsL_prm1, InsL_prm2	off	off	off	off	off	InsL_prm9	InsL_prm1
31(B15)	Blackpool	Or	White Room	Chorus 1	Thru	2Way Rotary Speaker	InsL_prm1	off	InsL_prm1	off	off	off	ELM-Lvl	RevSend
32(B16)	Tonewheels	Or	Room 1	Chorus 5	Thru	Thru	ELFO-PM, ELFO-AM, CLFOSpd	off	off	off	off	off	ELM-Lvl	ChoSend
33(C01)	BowNL	Or	Room 1	Chorus 1	Thru	Thru	RevSend, ELFO-PM	off	off	off	off	off	FLT-Frq	FLT-Rez
34(C02)	BassWalk	Or	Room 1	Chorus 1	Thru	Rotary Speaker 1	InsL_prm1	off	off	off	off	off	InsL_prm9	InsL_prm1
35(C03)	WhiteShade	Or	Hall 1	Chorus 1	3band EQ	Amp Simu + 2Way Rotary Speaker	InsL_prm1	off	off	off	off	off	FLT-Frq	RevSend
36(C04)	Draws	Or	Room 1	Chorus 1	Thru	2Way Rotary Speaker 3	InsL_prm16	off	InsL_prm2, InsL_prm3	off	off	off	InsL_prm14	InsL_prm5, InsL_prm6
37(C05)	PercMellow	Or	Room 1	Chorus 1	Thru	Rotary Speaker 1	InsL_prm1	off	off	off	off	off	InsL_prm9	InsL_prm1
38(C06)	RhoBassFiz	Or	Room 1	Chorus 1	AMP Simulator	Rotary Speaker 1	InsL_prm1, InsL_prm2	off	off	off	off	off	RevSend	InsL_prm1
39(C07)	Knob Drive	Or	Room 1	Chorus 1	AMP Simulator	Rotary Speaker 1	InsL_prm1	off	off	off	off	off	InsS_prm1	InsL_prm1
40(C08)	E Bird	Or	Hall 1	Chorus 4	Thru	Rotary Speaker 1	InsL_prm1	off	off	off	off	off	RevSend	ELM-Lvl
41(C09)	16--*-4	Or	Hall 1	Chorus 5	Thru	2Way Rotary Speaker	InsL_prm1, InsL_prm9	off	off	off	off	off	RevSend	ChoSend
42(C10)	16-5-4-1-1	Or	Hall 1	Chorus 5	Thru	Rotary Speaker 1	InsL_prm1, InsL_prm9	off	off	off	off	off	RevSend	ChoSend
43(C11)	Mw Church	Or	Hall 2	Celeste 1	Thru	Thru	ChoSend, ELM-Lvl	off	off	off	off	off	FLT-Frq	RevSend
44(C12)	Big Church	Or	Hall 2	Celeste 1	Thru	Thru	FLT-Frq	off	off	off	off	off	ChoSend	RevSend
45(C13)	Hawks	Gt	Hall 1	Chorus 1	Exciter	Harmonic Enhancer	ELFO-PM	off	off	off	off	off	FEG-D1	ChoSend
46(C14)	GoldGuitar	Gt	Room 3	Chorus 4	Thru	2Band EQ	ELFO-PM	off	off	off	off	off	RevSend	ChoSend
47(C15)	ElAc Mix	Gt	Hall 1	Delay LR	Chorus 1	Comp Distortion	ELFO-PM	off	off	off	off	off	ELM-Lvl, ELM-Lvl	ChoSend, RevSend
48(C16)	VintStrat	Gt	White Room	Delay LR	AMP Simulator	Tremolo	InsL_prm1	off	off	off	off	off	ChoSend	RevSend
49(D01)	StratChor3	Gt	Hall 1	Chorus 4	3band EQ	AMP Simulator	FLT-Frq	off	off	off	off	off	ChoSend	RevSend
50(D02)	VeloGuitar	Gt	Room 2	Chorus 4	Thru	AMP Simulator	ELFO-PM, ELFO-FM, ELFOSpd	off	off	off	off	off	InsL_prm10	ChoSend, Volume
51(D03)	Jazz Man	Gt	Stage 2	Chorus 5	Thru	Thru	ELFO-PM	off	off	off	off	off	RevSend	ChoSend
52(D04)	FMJazzGtr	Gt	Room 3	Chorus 4	Thru	Ambience	ELFO-PM	off	off	off	off	off	FLT-Frq	RevSend
53(D05)	Cry	Gt	Hall 1	Chorus 1	Auto Wah	Comp+Dist+Delay	ELFO-PM	InsL_prm14	off	off	off	off	InsS_prm1	ChoSend, Volume
54(D06)	P.F. Echo	Gt	Room 3	Delay LR	3band EQ	Dist + 2Way Rotary Speaker	ELFO-PM	off	off	off	off	off	ChoSend	InsL_prm14, Volume
55(D07)	Birdy	Gt	Room 3	Phaser	3band EQ	V-Distortion	ELFO-PM	off	off	off	off	off	InsL_prm1, Volume	InsL_prm11
56(D08)	Velo Chunk	Gt	Room 3	off	3band EQ	V-Distortion	ELFO-PM	off	off	off	off	off	InsL_prm4, InsL_prm1	InsL_prm11
57(D09)	VirtualDis	Gt	Hall 1	Delay LR	AMP Simulator	Comp Distortion	CLFO-D1	off	off	off	off	off	InsS_prm6	ChoSend
58(D10)	100 Watts	Gt	Room 3	Phaser	3band EQ	V-Distortion	ELFO-PM	off	off	off	off	off	InsL_prm11	InsL_prm1
59(D11)	Acst Vox	Co	Hall 1	Chorus 1	Thru	Delay LCR	ELM-Lvl	off	off	off	off	off	FLT-Frq, FLT-Rez	ChoSend
60(D12)	Prec Bass	Ba	Hall 1	Chorus 1	AMP Simulator	3Band EQ	CLFO-D1	off	off	off	off	off	ChoSend	InsL_prm1
61(D13)	Fing Sting	Ba	Hall 1	Chorus 1	Exciter	3Band EQ	CLFO-D1	off	off	off	off	off	ChoSend	InsL_prm1
62(D14)	FretlesAmp	Ba	Hall 1	Chorus 1	3band EQ	AMP Simulator	ELFO-PM	off	off	off	off	off	FLT-Frq	ChoSend
63(D15)	Slap&Pull	Ba	Room 1	Chorus 1	Thru	Thru	ELFO-PM	off	off	off	off	off	FLT-Frq, FLT-Frq	ChoSend
64(D16)	Bs+Cmbal	Co	Hall 1	Chorus 1	Thru	Thru	ELFO-PM	off	off	off	off	off	PCH-Crs	ELM-Lvl

No.	Voice Name	Category	Reverb Type	Chorus Type	Insertion1 Type	Insertion2 Type	MW	PB	AT	FC	BC	FS	Kn1	Kn2
65(E01)	Big Scion	St	Hall 1	Chorus 1	3band EQ	Thru	ChoSend, Volume	AEG-Rel	off	off	off	off	FLT-Frq	AEG-Atk
66(E02)	EnsembliMix	St	Hall 1	Ensemble	Thru	Thru	ChoSend, ELM-Lvl	off	off	off	off	off	FLT-Frq	AEG-Atk, AEG-Rel
67(E03)	Agitato	St	Hall 1	Chorus 1	3band EQ	Thru	ChoSend, Volume	off	off	off	off	off	FLT-Frq	ELFO-AM, ELFO-FM, CLFOSpd
68(E04)	Analog Mix	St	Hall 1	Ensemble	Thru	Thru	ChoSend, Volume	off	off	off	off	off	FLT-Frq	AEG-Atk, AEG-Rel
69(E05)	Violin	St	Hall 1	Chorus 1	Thru	Thru	FLT-Frq	off	off	off	off	off	AEG-Rel,AEG-Atk	ChoSend, RevSend, Volume
70(E06)	Big Pizz	St	Hall 1	Chorus 3	Thru	Thru	ChoSend	off	off	off	off	off	FLT-Frq	ELM-Dly
71(E07)	HarpStrum	St	Room 3	Celeste 2	Thru	Thru	ELFO-PM	off	off	off	off	off	RevSend	ChoSend
72(E08)	Wood Winds	Co	Hall 1	Ensemble	Thru	Thru	CLFO-D1, CLFO-D2, ELFO-PM, ELFO-FM	off	off	off	off	off	FLT-Frq	ChoSend
73(E09)	Pan Attack	Pi	Hall 1	Chorus 1	Thru	Thru	ELFO-AM, ELFO-FM	off	off	off	off	off	FLT-Frq, FLT-Rez	AEG-Atk
74(E10)	AnaString	St	Hall 2	Ensemble	Chorus 1	Cross Delay	CLFO-D1, FLT-Frq	off	off	off	off	off	InsS prm10	ChoSend
75(E11)	AnaString2	St	Hall 2	Symphonic	Chorus 3	Harmonic Enhancer	PCH-Fin	off	off	off	off	off	InsS prm3, InsS prm10, InsS prm6	InsL_prm2
76(E12)	Tron	St	Hall 1	Phaser	3band EQ	Thru	ELM-Lvl	off	off	off	off	off	RevSend, ChoSend	FLT-Frq
77(E13)	Brs/Strgs	Br	Hall 1	Chorus 1	Thru	Thru	ELM-Lvl	off	off	off	off	off	ELM-Lvl	PCH-Crs
78(E14)	MediumBrs2	Br	Hall 1	Chorus 1	3band EQ	Thru	ChoSend	off	off	off	off	off	FLT-Frq	RevSend
79(E15)	SoftBrass	Br	Hall 2	Chorus 1	Thru	Cross Delay	ChoSend	off	off	off	off	off	FLT-Frq	InsL_prm10, RevSend
80(E16)	HybrdBrs	Br	Hall 1	Chorus 1	Thru	Delay LCR	ELFO-PM, ELFO-FM	off	off	off	off	off	FLT-Frq, FLT-Rez	RevSend
81(F01)	Class Sect	Br	Hall 1	Chorus 3	Chorus 3	Thru	InsS prm10	off	off	off	off	off	FLT-Frq	ELM-Lvl
82(F02)	Sfz Brass	Br	Stage 2	Chorus 1	Thru	Thru	ELFO-PM, ELFO-PM	off	off	off	off	off	FLT-Frq	FEG-D2, FEG-D1
83(F03)	Pop Brass	Br	Hall 1	Chorus 1	Thru	Thru	ELFO-FM, ELFO-PM	off	off	off	off	off	FLT-Frq	ChoSend, Volume
84(F04)	Classical	Br	Hall 1	Chorus 1	Thru	Thru	ELFO-FM, ELFO-PM	off	off	off	off	off	FLT-Frq	ChoSend, Volume
85(F05)	Fr Horns	Br	Hall 1	Chorus 1	Thru	Delay LCR	ELFO-PM, ELFO-AM	off	off	off	off	off	RevSend	ChoSend
86(F06)	Flugel	Br	Hall 1	Ensemble	3band EQ	Thru	CLFO-D1, CLFO-D2	off	off	off	off	off	FLT-Frq	RevSend
87(F07)	Brth Tenor	Rd	Hall 2	Chorus 1	3band EQ	Thru	ELFO-PM, ELFO-AM	off	off	off	off	off	FLT-Frq	ChoSend, RevSend
88(F08)	Velo Growl	Rd	Hall 1	Delay LR	Thru	Thru	ELFO-PM, CLFO-D1	off	off	off	off	off	ChoSend	RevSend
89(F09)	NuSopno	Rd	Hall 1	Chorus 1	3band EQ	Thru	ELFO-PM, ELFO-AM	off	off	off	off	off	FLT-Frq	ChoSend
90(F10)	J Stabs	Br	Hall 1	Delay LR	Thru	Ensemble Detune	ELFO-PM	off	off	off	off	off	RevSend	ChoSend
91(F11)	Oberhorns	Br	Hall 1	Chorus 4	Thru	Cross Delay	CLFO-D1	off	off	off	off	off	FEG-Atk	ChoSend
92(F12)	Africa	Br	Hall 1	Delay LR	Thru	Thru	ELFO-PM	off	off	off	off	off	FLT-Frq, FLT-Rez	PEG-Dpt, AEG-Atk
93(F13)	NuTekBrss	Br	Hall 1	Chorus 4	Distortion	Cross Delay	ChoSend, ELM-Lvl	off	ELFO-PM	off	off	off	PCH-Fin	ChoSend
94(F14)	CS80Brass	Br	Hall 1	Delay LR	Thru	Thru	ELFO-PM	off	off	off	off	off	FLT-Frq, FLT-Rez	RevSend, ChoSend
95(F15)	Fat Brazz	Br	Hall 1	Chorus 4	Thru	Cross Delay	CLFO-D1	off	off	off	off	off	FEG-Atk	ChoSend
96(F16)	EgoSix	Br	Hall 2	Chorus 2	Compressor	Early Ref 1	ChoSend, RevSend, FLT-Frq	off	off	off	off	off	InsL_prm10	ChoSend
97(G01)	Ambi Star	Fx	Hall 2	Ensemble	Flanger 3	Cross Delay	FLT-Frq, FLT-Rez, ChoSend	off	off	off	off	off	InsS prm1	InsS prm10
98(G02)	Champ	Fx	Hall 2	Delay LR	Chorus 1	Ensemble Detune	FLT-Rez, ELM-Lvl	off	off	off	off	off	FEG-Atk	InsL_prm10
99(G03)	Rndm Gruv	Fx	Hall 2	Ensemble	Chorus 4	Cross Delay	CLFO-D1, ChoSend	off	off	off	off	off	ChoSend, ELM-Lvl	CLFO-D2
100(G04)	Generation	Sq	Hall 2	Tempo Cross Delay	Exciter	Ensemble Detune	FLT-Rez, FLT-Frq	off	off	off	off	off	FLT-Rez	InsS prm1
101(G05)	Molecule	Fx	Hall 1	Tempo Cross Delay	Phaser	Ensemble Detune	ELFO-FM, InsS prm1, InsS prm2	off	off	off	off	off	ELFOSpd	ELM-Lvl, ELM-Lvl
102(G06)	Teardrops	Fx	Room 3	Control Delay1	Phaser	Compressor	InsS prm4, AEG-Atk	off	off	off	off	off	InsS prm10	InsS prm1
103(G07)	Hades	Fx	Hall 1	Delay LR	Thru	Celeste 2	ELFO-PM	off	off	off	off	off	RevSend	ChoSend
104(G08)	Voyager	Fx	Canyon	Tempo Cross Delay	Phaser	Flanger 3	ELFO-FM	off	off	off	off	off	InsL_prm1, InsS prm1, ChoSend	ELFOSpd, FLT-Frq
105(G09)	Waterfowl	Fx	Stage 1	Tempo Cross Delay	Phaser	Harmonic Enhancer	ELFOSpd	off	off	off	off	off	InsS prm4	RevSend
106(G10)	Mayflower	Fx	Canyon	Tempo Cross Delay	Flanger 3	Compressor	ELFO-AM, PCH-Fin	off	off	off	off	off	ELFOSpd, ELFO-PM	InsS prm1
107(G11)	Cronen	Pd	Plate	off	Chorus 3	Rotary Speaker 1	InsL_prm1, InsL_prm9	off	off	off	off	off	ELM-Lvl, ELM-Lvl	InsS prm3
108(G12)	Padness	Pd	Canyon	Chorus 2	Touch Wah	Pitch Change 1	CLFO-D2	off	off	off	off	off	InsS prm8	InsL_prm10
109(G13)	Luminosity	Pd	Hall 1	Chorus 1	Flanger 2	Delay LCR	ELFO-AM	off	off	off	off	off	RevSend	ChoSend
110(G14)	Expanse	Pd	Hall 1	Chorus 1	Thru	Echo	ELFO-PM	off	off	off	off	off	ELM-Lvl	ChoSend
111(G15)	Vox 5ths	Pd	Hall 2	Symphonic	Thru	Delay LCR	PCH-Crs, PCH-Crs	off	off	off	off	off	FLT-Frq, FLT-Rez	ChoSend
112(G16)	Cleansing	Pd	Hall 1	Symphonic	Chorus 1	Delay LCR	CLFO-D1	off	off	off	off	off	ChoSend	FLT-Frq, RevSend
113(H01)	4000 Volts	Se	Hall 1	Chorus 1	Chorus 3	Flanger 1	FLT-Frq	off	InsL_prm3	off	off	off	PEG-Dpt	FEG-Atk
114(H02)	Rainstnrm	Se	Hall 1	Chorus 3	Thru	Thru	FLT-Frq	off	off	off	off	off	PCH-Crs	ELM-Lvl
115(H03)	RadioNoiz	Se	Hall 1	Chorus 3	3band EQ	LO-FI	ELFOSpd	InsL_prm2	off	off	off	off	FLT-Frq	InsL_prm1
116(H04)	Turntablz	Se	Hall 1	Chorus 1	Thru	LO-FI	ELFO-PM, ELFO-FM	off	off	off	off	off	ChoSend	PCH-Crs
117(H05)	Manufactur	Se	Room 1	Ensemble	Phaser	Delay LR	ELFO-PM	off	off	off	off	off	ELM-Pan, ELM-Pan	RevSend
118(H06)	Zap	Se	Hall 1	Control Delay1	3band EQ	Thru	PCH-Crs	AEG-D1	off	off	off	off	PEG-Hld	ChoSend, RevSend
119(H07)	Helicoptr	Se	Hall 1	Phaser	Thru	Auto Pan	FLT-Rez, FLT-Frq, FLT-Frq	ELFOSpd	off	off	off	off	ELM-Lvl	RevSend
120(H08)	Sirens	Se	Hall 1	Chorus 1	Thru	Thru	RevSend	off	off	off	off	off	ELFOSpd	ChoSend
121(H09)	Bubbles	Se	Hall 1	Chorus 3	3band EQ	LO-FI	ELFOSpd	InsL_prm2	off	off	off	off	FLT-Frq	InsL_prm1
122(H10)	Beatniks	Pc	Hall 1	Tempo Delay1	Thru	Thru	ChoSend	off	off	off	off	off	FLT-Frq, FEG-Dpt	ELM-Lvl
123(H11)	Cybr Whip	Pc	Stage 2	Chorus 1	Thru	V-Flanger	InsL_prm2	off	off	off	off	off	FLT-Frq	AEG-Atk
124(H12)	Voiccy	En	Hall 2	Chorus 1	Compressor	Hall 2	ELM-Lvl, ELM-Lvl, FLT-Frq	off	off	off	off	off	ELM-Pan	RevSend
125(H13)	FormantStg	En	Hall 1	Chorus 1	Chorus 2	Talking Modulator	InsL_prm1	off	off	off	off	off	FLT-Frq	FLT-Rez
126(H14)	Airy	Vo	Hall 1	Control Delay2	Thru	Thru	ELFO-PM	off	off	off	off	off	PCH-Crs	AEG-Atk, AEG-Rel
127(H15)	Chandeller	Vo	Hall 2	Ensemble	Exciter	Chorus 4	InsS prm1, ELM-Lvl, FLT-Frq	off	off	off	off	off	InsS prm1	FLT-Frq
128(H16)	Choir Atk	Vo	Hall 1	Chorus 1	Exciter	3Band EQ	ELFO-PM, ELFO-AM	off	off	off	off	off	FLT-Frq	FLT-Rez

クイックアクセスボイスリスト

Bank	Category	Program Key	Memory	Voice Program Number	Voice Name
A	A.PIANO	1	PRE1	1	StereoGrnd
		2	PRE1	2	StereoGnd2
		3	PRE1	3	CF Grand M
		4	PRE1	4	Dark Grand
		5	PRE1	5	Difference
		6	PRE2	114	Slamming
		7	PRE1	9	CP2000
		8	PRE2	124	For Ballad
		9	PRE1	7	Piano/Strg
		10	PRE1	8	Piano/Oohs
		11	PRE1	6	Piano/Ep
		12	PRE1	10	Piano/DX
		13	INT	1	Hybrid
		14	INT	2	DarkGrand2
		15	INT	3	BrtStereo
		16	INT	4	HonkyTrnk2
B	E.PIANO	1	PRE1	17	Vic'sRoadz
		2	PRE1	18	ErlyFusion
		3	PRE1	16	19 Roadz
		4	PRE1	20	VintgCond
		5	PRE1	11	Wurlitrm
		6	PRE1	13	DF EP IV
		7	PRE1	14	Herb Roadz
		8	PRE1	21	DXAtacky
		9	PRE1	24	Ice Piano
		10	PRE1	26	Bel Roadz
		11	PRE1	31	Clav
		12	PRE1	30	Harpsicode
		13	INT	17	Doogie
		14	INT	18	RT Roadz
		15	INT	19	Dyno Pad
		16	INT	20	Roadz Pad
C	ORGAN	1	PRE1	33	Perc Org
		2	PRE1	34	Cool
		3	PRE1	35	ClickOrgan
		4	PRE1	36	Jazz
		5	PRE1	37	Soft Rock
		6	PRE1	38	Tube
		7	PRE1	39	Contnental
		8	PRE1	40	Swish
		9	PRE1	44	Sunday
		10	PRE1	45	Pipes
		11	PRE1	41	4 Bars
		12	PRE1	42	Full
		13	INT	33	BowNL
		14	INT	34	BassWalk
		15	INT	35	WhiteShade
		16	INT	36	Draws
D	GTR/BASS	1	PRE1	46	New Nylon
		2	PRE1	48	Melo Trmlo
		3	PRE1	54	DirtyTwn
		4	PRE1	49	Strat Chor
		5	PRE1	56	BOODOO MAN
		6	PRE1	52	Acoustic
		7	PRE1	58	Funk It!!
		8	PRE1	59	Upright
		9	PRE1	60	Finger
		10	PRE1	61	PickBass
		11	PRE1	62	Fretless
		12	PRE1	63	Slap
		13	INT	49	StratChor3
		14	INT	50	3VeloGuitar
		15	INT	51	Jazz Man
		16	INT	52	FMJazzGtr
E	STRINGS	1	PRE1	65	Background
		2	PRE1	66	Big String
		3	PRE1	67	Cello Big
		4	PRE1	68	Chamberz
		5	PRE1	69	SmallSect
		6	PRE1	70	CelloSmall
		7	PRE1	76	Wind Orch
		8	PRE1	77	SynthStrgs
		9	PRE1	78	ObiStrings
		10	PRE2	57	Big Syn
		11	PRE1	71	Pizz
		12	PRE1	72	Harp
		13	INT	65	Big Sction
		14	INT	66	EnsemblMix
		15	INT	67	Agitato
		16	INT	68	Analog Mix

Bank	Category	Program Key	Memory	Voice Program Number	Voice Name
F	BRASS	1	PRE1	79	Fanfare
		2	PRE1	80	MediumBrss
		3	PRE1	81	Two Brass
		4	PRE1	82	Brass&Sax
		5	PRE1	85	Trumpet
		6	PRE1	86	Mute Trpt
		7	PRE1	87	Tenor Sax
		8	PRE1	88	Alto Sax
		9	PRE1	90	Soprano
		10	PRE1	92	PowerSynth
		11	PRE1	94	M Brass
		12	PRE1	95	Moon AT
		13	INT	81	Class Sect
		14	INT	82	Sfz Brass
		15	INT	83	Pop Brass
		16	INT	84	Classical
G	SYNTH	1	PRE1	101	Soft Pad
		2	PRE2	50	5thBreath
		3	PRE2	63	Soft Dream
		4	PRE2	58	Berlin
		5	PRE1	111	Liquito
		6	PRE2	22	Zap Comp
		7	PRE2	36	Lucky
		8	PRE2	37	Sneaky
		9	PRE2	40	Rap Lead3
		10	PRE2	5	Mini 1
		11	PRE2	3	Velo
		12	PRE2	109	Super DX
		13	INT	97	Ambi Star
		14	INT	98	Champ
		15	INT	99	Rndm Gruv
		16	INT	100	Generation
H	OTHER	1	PRE1	113	Vibes
		2	PRE1	114	Marimba
		3	PRE1	117	Glocken
		4	PRE1	97	Ooh Choir
		5	PRE1	98	Ahh Choir
		6	PRE2	101	Starlight
		7	PRE2	93	RisingHigh
		8	PRE2	67	Kickwheel
		9	PRE2	70	Rosy
		10	PRE2	73	Synfonic
		11	PRE2	74	Hard road
		12	PRE2	76	Atom
		13	INT	113	4000 Volts
		14	INT	114	RainStorm
		15	INT	115	RadioNoiz
		16	INT	116	Turntablz

ドラムボイスリスト

Preset (MSB=63, LSB=32)

1 Rock Kit

Note	ElmAsgn	Wave No.	Wave Name
C 0	on	378	Dr BdVar5
C#0	on	389	Dr SdPcBH
D 0	on	391	Dr SdWdH
D#0	on	392	Dr SdVar1
E 0	on	376	Dr BdVar3
F 0	on	405	Dr SdRoll
F#0	on	382	Dr SdBldH
G 0	on	400	Dr SdDry
G#0	on	408	Dr Stick
A 0	on	377	Dr BdVar4
A#0	on	389	Dr SdPcBH
B 0	on	374	Dr BdVar1
C 1	on	371	Dr BdPop
C#1	on	407	Dr C.Rim2
D 1	on	387	Dr SdHvy
D#1	on	358	Pc Clap
E 1	on	380	Dr SdGM
F 1	on	418	Dr Tom2L
F#1	on	423	Dr HHCl5
G 1	on	418	Dr Tom2L
G#1	on	425	Dr HHPd2
A 1	on	418	Dr Tom2L
A#1	on	426	Dr HHOpn
B 1	on	417	Dr Tom2H
C 2	on	417	Dr Tom2H
C#2	on	433	Dr Crash
D 2	on	417	Dr Tom2H
D#2	on	429	Dr Ride
E 2	on	435	Dr China
F 2	on	431	Dr Cup
F#2	on	354	Pc Tmborn
G 2	on	434	Dr Crash2
G#2	on	340	Pc Cowbel
A 2	on	434	Dr Crash2
A#2	on	356	Pc VbSlp
B 2	on	432	Dr Cup2
C 3	on	336	Pc BongoH
C#3	on	335	Pc BongoL
D 3	on	339	Pc CngSlp
D#3	on	338	Pc CongaH
E 3	on	337	Pc CongaL
F 3	on	345	Pc TmblsH
F#3	on	344	Pc TmblsL
G 3	on	341	Pc AgogoL
G#3	on	341	Pc AgogoL
A 3	on	349	Pc Cabasa
A#3	on	352	Pc Maracs
B 3	on	435	Dr China
C 4	on	434	Dr Crash2
C#4	on	355	Pc TrangL
D 4	on	101	Cp FngCym
D#4	on	350	Pc Claves
E 4	on	348	Pc Wdblck
F 4	on	348	Pc Wdblck
F#4	on	113	Cp Timpni
G 4	on	113	Cp Timpni
G#4	on	355	Pc TrangL
A 4	on	355	Pc TrangL
A#4	on	353	Pc Shaker
B 4	on	357	Pc JnglBl
C 5	on	370	Dr BdStd
C#5	on	394	Dr SdRim1
D 5	on	382	Dr SdBldH
D#5	on	387	Dr SdHvy
E 5	on	392	Dr SdVar1
F 5	on	393	Dr SdVar2
F#5	on	396	Dr SdAmb1
G 5	on	383	Dr SdFsnH
G#5	on	398	Dr SdAmb3
A 5	on	388	Dr SdPclH
A#5	on	372	Dr BdHby
B 5	on	372	Dr BdHby
C 6	on	373	Dr BdLoJz

2 House Kit

Note	ElmAsgn	Wave No.	Wave Name
C 0	off		
C#0	off		
D 0	off		
D#0	off		
E 0	on	433	Dr Crash
F 0	on	373	Dr BdLoJz
F#0	on	367	Pc CONG
G 0	on	382	Dr SdBldH
G#0	on	367	Pc CONG
A 0	on	476	Dr EuroBD
A#0	on	437	Dr T8BdBm
B 0	on	457	Dr T9BD2
C 1	on	458	Dr T9BD3
C#1	on	466	Dr T9Rim
D 1	on	460	Dr T9SD2
D#1	on	444	Dr T8Rmst
E 1	on	463	Dr T9SD5
F 1	on	467	Dr T9TomL
F#1	on	470	Dr T9HHC1
G 1	on	468	Dr T9TomM
G#1	on	471	Dr T9HHC2
A 1	on	469	Dr T9TomH
A#1	on	472	Dr T9HHO1
B 1	on	469	Dr T9TomH
C 2	on	473	Dr T9HHO2
C#2	on	474	Dr T9Crsh
D 2	on	475	Dr T9Ride
D#2	on	465	Dr T9Clap
E 2	on	362	Pc AnvlPp
F 2	on	456	Dr T9BD1
F#2	on	389	Dr SdPcBH
G 2	on	369	Pc WdBlk
G#2	on	362	Pc AnvlPp
A 2	on	367	Pc CONG
A#2	on	361	Pc AnvlHt
B 2	on	368	Pc StlClp
C 3	on	366	Pc Ripper
C#3	on	367	Pc CONG
D 3	on	452	Dr T8CngH
D#3	on	452	Dr T8CngH
E 3	on	452	Dr T8CngH
F 3	on	452	Dr T8CngH
F#3	on	449	Dr T8Crsh
G 3	on	447	Dr T8HHCl
G#3	on	448	Dr T8HHOp
A 3	on	355	Pc TrangL
A#3	on	455	Dr T8Mrcs
B 3	on	355	Pc TrangL
C 4	on	353	Pc Shaker
C#4	on	361	Pc AnvlHt
D 4	on	361	Pc AnvlHt
D#4	on	454	Dr T8Clve
E 4	on	365	Pc VoxDrm
F 4	on	477	Dr DstKik
F#4	on	449	Dr T8Crsh
G 4	on	357	Pc JnglBl
G#4	on	354	Pc Tmborn
A 4	on	354	Pc Tmborn
A#4	on	322	Fx BigSyn
B 4	on	322	Fx BigSyn
C 5	on	319	Fx Melow
C#5	on	328	Fx VxAlk
D 5	on	328	Fx VxAlk
D#5	on	328	Fx VxAlk
E 5	on	439	Dr T8SD1
F 5	on	359	Pc Whistl
F#5	on	388	Dr SdPclH
G 5	on	437	Dr T8BdBm
G#5	off		
A 5	off		
A#5	off		
B 5	off		
C 6	off		

3 Hip Kit

Note	ElmAsgn	Wave No.	Wave Name
C 0	on	477	Dr DstKik
C#0	on	378	Dr BdVar5
D 0	on	377	Dr BdVar4
D#0	on	437	Dr T8BdBm
E 0	on	456	Dr T9BD1
F 0	on	382	Dr SdBldH
F#0	on	388	Dr SdPclH
G 0	on	390	Dr SdPrmH
G#0	on	439	Dr T8SD1
A 0	on	399	Dr SdBkbt
A#0	on	404	Dr SdBrsL
B 0	on	437	Dr T8BdBm
C 1	on	379	Dr BdAna
C#1	on	407	Dr C.Rim2
D 1	on	394	Dr SdRim1
D#1	on	445	Dr T8Clap
E 1	on	389	Dr SdPcBH
F 1	on	409	Dr TomF
F#1	on	420	Dr HHCl2
G 1	on	409	Dr TomF
G#1	on	447	Dr T8HHCl
A 1	on	410	Dr TomL
A#1	on	426	Dr HHOpn
B 1	on	411	Dr TomM
C 2	on	412	Dr TomHL
C#2	on	433	Dr Crash
D 2	on	413	Dr TomHH
D#2	on	430	Dr Ride2
E 2	on	435	Dr China
F 2	on	432	Dr Cup2
F#2	on	354	Pc Tmborn
G 2	on	434	Dr Crash2
G#2	on	367	Pc CONG
A 2	on	434	Dr Crash2
A#2	on	356	Pc VbSlp
B 2	on	429	Dr Ride
C 3	on	331	Fx AHoseL
C#3	on	332	Fx AHoseR
D 3	on	339	Pc CngSlp
D#3	on	338	Pc CongaH
E 3	on	337	Pc CongaL
F 3	on	345	Pc TmblsH
F#3	on	344	Pc TmblsL
G 3	on	362	Pc AnvlPp
G#3	on	362	Pc AnvlPp
A 3	on	353	Pc Shaker
A#3	on	352	Pc Maracs
B 3	on	363	Pc Scrch1
C 4	on	438	Dr T8Bd
C#4	on	368	Pc StlClp
D 4	on	383	Dr SdFsnH
D#4	on	465	Dr T9Clap
E 4	on	393	Dr SdVar2
F 4	on	357	Pc JnglBl
F#4	on	470	Dr T9HHC1
G 4	on	355	Pc TrangL
G#4	on	471	Dr T9HHC2
A 4	on	355	Pc TrangL
A#4	on	472	Dr T9HHO1
B 4	on	329	Fx HiLo
C 5	on	325	Fx Eery
C#5	on	474	Dr T9Crsh
D 5	on	435	Dr China
D#5	on	318	Fx VoxBel
E 5	on	319	Fx Melow
F 5	on	255	Wv MogBs1
F#5	on	354	Pc Tmborn
G 5	on	364	Pc Scrch2
G#5	on	475	Dr T9Ride
A 5	on	325	Fx Eery
A#5	on	327	Fx HH Hit
B 5	on	323	Fx TrnCho
C 6	on	323	Fx TrnCho

4 Trance Kit

Note	ElmAsgn	Wave No.	Wave Name
C 0	on	437	Dr T8BdBm
C#0	on	451	Dr T8CngM
D 0	on	438	Dr T8Bd
D#0	on	452	Dr T8CngH
E 0	on	457	Dr T9BD2
F 0	on	457	Dr T9BD2
F#0	on	367	Pc CONG
G 0	on	459	Dr T9SD1
G#0	on	367	Pc CONG
A 0	on	476	Dr EuroBD
A#0	on	476	Dr EuroBD
B 0	on	457	Dr T9BD2
C 1	on	458	Dr T9BD3
C#1	on	466	Dr T9Rim
D 1	on	459	Dr T9SD1
D#1	on	477	Dr DstKik
E 1	on	462	Dr T9SD4
F 1	on	467	Dr T9TomL
F#1	on	470	Dr T9HHC1
G 1	on	468	Dr T9TomM
G#1	on	471	Dr T9HHC2
A 1	on	469	Dr T9TomH
A#1	on	472	Dr T9HHO1
B 1	on	469	Dr T9TomH
C 2	on	473	Dr T9HHO2
C#2	on	474	Dr T9Crsh
D 2	on	475	Dr T9Ride
D#2	on	465	Dr T9Clap
E 2	on	362	Pc AnvlPp
F 2	on	456	Dr T9BD1
F#2	on	389	Dr SdPcBH
G 2	on	369	Pc WdBlk
G#2	on	362	Pc AnvlPp
A 2	on	366	Pc Ripper
A#2	on	361	Pc AnvlHt
B 2	on	368	Pc StlClp
C 3	on	437	Dr T8BdBm
C#3	on	367	Pc CONG
D 3	on	452	Dr T8CngH
D#3	on	452	Dr T8CngH
E 3	on	452	Dr T8CngH
F 3	on	452	Dr T8CngH
F#3	on	449	Dr T8Crsh
G 3	on	447	Dr T8HHCl
G#3	on	448	Dr T8HHOp
A 3	on	355	Pc TrangL
A#3	on	455	Dr T8Mrcs
B 3	on	355	Pc TrangL
C 4	on	320	Fx WndChm
C#4	on	321	Fx BelAir
D 4	on	322	Fx BigSyn
D#4	on	326	Fx Electr
E 4	on	327	Fx HH Hit
F 4	on	328	Fx VxAlk
F#4	on	328	Fx VxAlk
G 4	on	329	Fx HiLo
G#4	on	329	Fx HiLo
A 4	on	318	Fx VoxBel
A#4	on	318	Fx VoxBel
B 4	on	325	Fx Eery
C 5	on	258	Wv FMBs1
C#5	on	258	Wv FMBs1
D 5	on	258	Wv FMBs1
D#5	on	258	Wv FMBs1
E 5	on	258	Wv FMBs1
F 5	on	258	Wv FMBs1
F#5	on	258	Wv FMBs1
G 5	on	258	Wv FMBs1
G#5	on	258	Wv FMBs1
A 5	on	258	Wv FMBs1
A#5	on	258	Wv FMBs1
B 5	on	258	Wv FMBs1
C 6	on	258	Wv FMBs1

5 Nasty Kit

Note	ElmAsgn	Wave No.	Wave Name
C 0	on	438	Dr T8Bd
C#0	on	377	Dr BdVar4
D 0	on	337	Pc CongaL
D#0	on	379	Dr BdAna
E 0	on	458	Dr T9BD3
F 0	on	397	Dr SdAmb2
F#0	on	395	Dr SdRim2
G 0	on	439	Dr T8SD1
G#0	on	441	Dr T8SD3
A 0	on	403	Dr SdBrsH
A#0	on	398	Dr SdAmb3
B 0	on	476	Dr EuroBD
C 1	on	458	Dr T9BD3
C#1	on	329	Fx HiLo
D 1	on	462	Dr T9SD4
D#1	on	445	Dr T8Clap
E 1	on	369	Pc WdBlk
F 1	on	314	Wv Noise
F#1	on	423	Dr HHCl5
G 1	on	314	Wv Noise
G#1	on	470	Dr T9HHC1
A 1	on	314	Wv Noise
A#1	on	472	Dr T9HHC1
B 1	on	418	Dr Tom2L
C 2	on	417	Dr Tom2H
C#2	on	474	Dr T9Crsh
D 2	on	417	Dr Tom2H
D#2	on	325	Fx Eery
E 2	on	435	Dr China
F 2	on	432	Dr Cup2
F#2	on	354	Pc Tmborn
G 2	on	433	Dr Crash
G#2	on	255	Wv MogBs1
A 2	on	434	Dr Crash2
A#2	on	356	Pc VbSlp
B 2	on	429	Dr Ride
C 3	on	328	Fx VdAlk
C#3	on	327	FX HH Hit
D 3	on	345	Pc TmbIsH
D#3	on	338	Pc CongaH
E 3	on	337	Pc CongaL
F 3	on	321	Fx BelAir
F#3	on	326	Fx Electr
G 3	on	362	Pc AnvlPp
G#3	on	362	Pc AnvlPp
A 3	on	353	Pc Shaker
A#3	on	352	Pc Maracs
B 3	on	360	Pc Bltree
C 4	on	438	Dr T8Bd
C#4	on	318	Fx VoxBel
D 4	on	397	Dr SdAmb2
D#4	on	465	Dr T9Clap
E 4	on	394	Dr SdRim1
F 4	on	330	Fx MitPno
F#4	on	447	Dr T8HHC1
G 4	on	361	Pc AnvlHt
G#4	on	471	Dr T9HHC2
A 4	on	361	Pc AnvlHt
A#4	on	448	Dr T8HHOp
B 4	on	325	Fx Eery
C 5	on	325	Fx Eery
C#5	on	474	Dr T9Crsh
D 5	on	435	Dr China
D#5	on	318	Fx VoxBel
E 5	on	449	Dr T8Crsh
F 5	on	209	En VxNoiz
F#5	on	354	Pc Tmborn
G 5	on	366	Pc Ripper
G#5	on	475	Dr T9Ride
A 5	on	450	Dr T8CngL
A#5	on	451	Dr T8CngM
B 5	on	416	Dr TmjzH
C 6	on	448	Dr T8HHOp

6 Brush Kit

Note	ElmAsgn	Wave No.	Wave Name
C 0	on	350	Pc Claves
C#0	on	404	Dr SdBrsL
D 0	on	401	Dr SdSweep
D#0	on	403	Dr SdBrsH
E 0	on	401	Dr SdSweep
F 0	on	405	Dr SdRoll
F#0	on	351	Pc Castnt
G 0	on	404	Dr SdBrsL
G#0	on	408	Dr Stick
A 0	on	376	Dr BdVar3
A#0	on	403	Dr SdBrsH
B 0	on	377	Dr BdVar4
C 1	on	373	Dr BdLoJz
C#1	on	403	Dr SdBrsH
D 1	on	404	Dr SdBrsL
D#1	on	358	Pc Clap
E 1	on	402	Dr SdBrsS
F 1	on	414	Dr TmjzL
F#1	on	422	Dr HHCl4
G 1	on	414	Dr TmjzL
G#1	on	424	Dr HHPdl
A 1	on	414	Dr TmjzL
A#1	on	426	Dr HHOpn
B 1	on	415	Dr TmjzM
C 2	on	416	Dr TmjzH
C#2	on	433	Dr Crash
D 2	on	416	Dr TmjzH
D#2	on	429	Dr Ride
E 2	on	430	Dr Ride2
F 2	on	431	Dr Cup
F#2	on	354	Pc Tmborn
G 2	on	434	Dr Crash2
G#2	on	340	Pc Cowbel
A 2	on	434	Dr Crash2
A#2	on	429	Dr Ride
B 2	on	432	Dr Cup2
C 3	on	336	Pc BongoH
C#3	on	335	Pc BongoL
D 3	on	339	Pc CngSlp
D#3	on	338	Pc CongaH
E 3	on	337	Pc CongaL
F 3	on	345	Pc TmbIsH
F#3	on	344	Pc TmbIsL
G 3	on	341	Pc AgogoL
G#3	on	341	Pc AgogoL
A 3	on	349	Pc Cabasa
A#3	on	352	Pc Maracs
B 3	on	359	Pc Whistl
C 4	on	359	Pc Whistl
C#4	on	343	Pc GiroCl
D 4	on	342	Pc GuiroL
D#4	on	350	Pc Claves
E 4	on	348	Pc Wdbclk
F 4	on	348	Pc Wdbclk
F#4	on	346	Pc Cuical
G 4	on	347	Pc CuicaH
G#4	on	355	Pc TrangL
A 4	on	355	Pc TrangL
A#4	on	353	Pc Shaker
B 4	on	357	Pc JnglBl
C 5	on	360	Pc Bltree
C#5	off		
D 5	off		
D#5	off		
E 5	off		
F 5	off		
F#5	off		
G 5	off		
G#5	off		
A 5	off		
A#5	off		
B 5	off		
C 6	off		

7 Pop Kit

Note	ElmAsgn	Wave No.	Wave Name
C 0	on	350	Pc Claves
C#0	on	404	Dr SdBrsL
D 0	on	401	Dr SdSweep
D#0	on	403	Dr SdBrsH
E 0	on	401	Dr SdSweep
F 0	on	405	Dr SdRoll
F#0	on	351	Pc Castnt
G 0	on	400	Dr SdDry
G#0	on	408	Dr Stick
A 0	on	376	Dr BdVar3
A#0	on	389	Dr SdPcBH
B 0	on	377	Dr BdVar4
C 1	on	372	Dr BdHby
C#1	on	406	Dr C.Rim1
D 1	on	380	Dr SdGM
D#1	on	358	Pc Clap
E 1	on	380	Dr SdGM
F 1	on	410	Dr TomL
F#1	on	423	Dr HHCl5
G 1	on	410	Dr TomL
G#1	on	425	Dr HHPdl2
A 1	on	411	Dr TomM
A#1	on	427	Dr HHOpn2
B 1	on	411	Dr TomM
C 2	on	412	Dr TomHL
C#2	on	433	Dr Crash
D 2	on	413	Dr TomHH
D#2	on	429	Dr Ride
E 2	on	435	Dr China
F 2	on	431	Dr Cup
F#2	on	354	Pc Tmborn
G 2	on	434	Dr Crash2
G#2	on	340	Pc Cowbel
A 2	on	434	Dr Crash2
A#2	on	356	Pc VbSlp
B 2	on	432	Dr Cup2
C 3	on	336	Pc BongoH
C#3	on	335	Pc BongoL
D 3	on	339	Pc CngSlp
D#3	on	338	Pc CongaH
E 3	on	337	Pc CongaL
F 3	on	345	Pc TmbIsH
F#3	on	344	Pc TmbIsL
G 3	on	341	Pc AgogoL
G#3	on	341	Pc AgogoL
A 3	on	349	Pc Cabasa
A#3	on	352	Pc Maracs
B 3	on	359	Pc Whistl
C 4	on	359	Pc Whistl
C#4	on	343	Pc GiroCl
D 4	on	342	Pc GuiroL
D#4	on	350	Pc Claves
E 4	on	348	Pc Wdbclk
F 4	on	348	Pc Wdbclk
F#4	on	346	Pc Cuical
G 4	on	347	Pc CuicaH
G#4	on	355	Pc TrangL
A 4	on	355	Pc TrangL
A#4	on	353	Pc Shaker
B 4	on	357	Pc JnglBl
C 5	on	360	Pc Bltree
C#5	on	399	Dr SdBkBT
D 5	on	381	Dr SdBldS
D#5	on	392	Dr SdVar1
E 5	on	386	Dr SdSonD
F 5	on	394	Dr SdRim1
F#5	on	391	Dr SdWdH
G 5	on	382	Dr SdBldH
G#5	on	389	Dr SdPcBH
A 5	on	384	Dr SdLdwH
A#5	on	371	Dr BdPop
B 5	on	372	Dr BdHby
C 6	on	378	Dr BdVar5

8 808 Kit

Note	ElmAsgn	Wave No.	Wave Name
C 0	on	350	Pc Claves
C#0	on	404	Dr SdBrsL
D 0	on	401	Dr SdSweep
D#0	on	403	Dr SdBrsH
E 0	on	401	Dr SdSweep
F 0	on	405	Dr SdRoll
F#0	on	351	Pc Castnt
G 0	on	442	Dr T8SD4
G#0	on	444	Dr T8Rmst
A 0	on	379	Dr BdAna
A#0	on	441	Dr T8SD3
B 0	on	437	Dr T8BdBm
C 1	on	438	Dr T8Bd
C#1	on	443	Dr T8Side
D 1	on	439	Dr T8SD1
D#1	on	445	Dr T8Clap
E 1	on	440	Dr T8SD2
F 1	on	446	Dr T8Tom
F#1	on	447	Dr T8HHC1
G 1	on	446	Dr T8Tom
G#1	on	448	Dr T8HHOp
A 1	on	446	Dr T8Tom
A#1	on	448	Dr T8HHOp
B 1	on	446	Dr T8Tom
C 2	on	446	Dr T8Tom
C#2	on	449	Dr T8Crsh
D 2	on	446	Dr T8Tom
D#2	on	449	Dr T8Crsh
E 2	on	435	Dr China
F 2	on	431	Dr Cup
F#2	on	354	Pc Tmborn
G 2	on	434	Dr Crash2
G#2	on	453	Dr T8Cwbl
A 2	on	434	Dr Crash2
A#2	on	356	Pc VbSlp
B 2	on	430	Dr Ride2
C 3	on	336	Pc BongoH
C#3	on	335	Pc BongoL
D 3	on	452	Dr T8CngH
D#3	on	451	Dr T8CngM
E 3	on	450	Dr T8CngL
F 3	on	345	Pc TmbIsH
F#3	on	344	Pc TmbIsL
G 3	on	341	Pc AgogoL
G#3	on	341	Pc AgogoL
A 3	on	349	Pc Cabasa
A#3	on	455	Dr T8Mrcs
B 3	on	359	Pc Whistl
C 4	on	359	Pc Whistl
C#4	on	343	Pc GiroCl
D 4	on	342	Pc GuiroL
D#4	on	454	Dr T8Clve
E 4	on	348	Pc Wdbclk
F 4	on	348	Pc Wdbclk
F#4	on	346	Pc Cuical
G 4	on	347	Pc CuicaH
G#4	on	355	Pc TrangL
A 4	on	355	Pc TrangL
A#4	on	353	Pc Shaker
B 4	on	357	Pc JnglBl
C 5	on	360	Pc Bltree
C#5	off		
D 5	off		
D#5	off		
E 5	off		
F 5	off		
F#5	off		
G 5	off		
G#5	off		
A 5	off		
A#5	off		
B 5	off		
C 6	off		

Internal (MSB=63, LSB=40)

1 HipHop Kit

Note	ElmAsgn	Wave No.	Wave Name
C 0	on	437	Dr T8BdBm
C#0	on	440	Dr T8SD2
D 0	on	439	Dr T8SD1
D#0	on	441	Dr T8SD3
E 0	on	442	Dr T8SD4
F 0	on	462	Dr T9SD4
F#0	on	327	FX HH Hit
G 0	on	460	Dr T9SD2
G#0	on	444	Dr T8Rmst
A 0	on	438	Dr T8Bd
A#0	on	463	Dr T9SD5
B 0	on	458	Dr T9BD3
C 1	on	456	Dr T9BD1
C#1	on	406	Dr C.Rim1
D 1	on	459	Dr T9SD1
D#1	on	465	Dr T9Clap
E 1	on	461	Dr T9SD3
F 1	on	467	Dr T9TomL
F#1	on	471	Dr T9HHC2
G 1	on	467	Dr T9TomL
G#1	on	473	Dr T9HHO2
A 1	on	468	Dr T9TomM
A#1	on	472	Dr T9HHO1
B 1	on	468	Dr T9TomM
C 2	on	469	Dr T9TomH
C#2	on	474	Dr T9Crsh
D 2	on	469	Dr T9TomH
D#2	on	475	Dr T9Ride
E 2	on	449	Dr T8Crsh
F 2	on	475	Dr T9Ride
F#2	on	354	Pc Tmborn
G 2	on	449	Dr T8Crsh
G#2	on	453	Dr T8Cwbl
A 2	on	474	Dr T9Crsh
A#2	on	477	Dr DstKik
B 2	on	449	Dr T8Crsh
C 3	on	452	Dr T8CngH
C#3	on	450	Dr T8CngL
D 3	on	451	Dr T8CngM
D#3	on	255	Wv MogBs1
E 3	on	266	Wv Late-S
F 3	on	399	Dr SdBkbt
F#3	on	399	Dr SdBkbt
G 3	on	453	Dr T8Cwbl
G#3	on	341	Pc AgogoL
A 3	on	349	Pc Cabasa
A#3	on	455	Dr T8Mrcs
B 3	on	329	Fx HiLo
C 4	on	329	Fx HiLo
C#4	on	361	Pc AnvlHt
D 4	on	366	Pc Ripper
D#4	on	454	Dr T8Clve
E 4	on	454	Dr T8Clve
F 4	on	351	Pc Castnt
F#4	on	363	Pc Scrch1
G 4	on	364	Pc Scrch2
G#4	on	355	Pc TrangL
A 4	on	355	Pc TrangL
A#4	on	353	Pc Shaker
B 4	on	357	Pc JnglBl
C 5	on	360	Pc Bltree
C#5	on	394	Dr SdRim1
D 5	on	388	Dr SdPclH
D#5	on	358	Pc Clap
E 5	on	390	Dr SdPrmH
F 5	on	379	Dr BdAna
F#5	on	447	Dr T8HHC1
G 5	on	457	Dr T9BD2
G#5	on	423	Dr HHC15
A 5	on	374	Dr BdVar1
A#5	on	448	Dr T8HHOp
B 5	on	476	Dr EuroBD
C 6	on	372	Dr BdHby

2 Urbanguard

Note	ElmAsgn	Wave No.	Wave Name
C 0	on	378	Dr BdVar5
C#0	on	404	Dr SdBrsL
D 0	on	401	Dr SdSwep
D#0	on	403	Dr SdBrsH
E 0	on	401	Dr SdSwep
F 0	on	405	Dr SdRoll
F#0	on	314	Wv Noise
G 0	on	385	Dr SdSonA
G#0	on	408	Dr Stick
A 0	on	378	Dr BdVar5
A#0	on	389	Dr SdPcBH
B 0	on	375	Dr BdVar2
C 1	on	373	Dr BdLoJz
C#1	on	407	Dr C.Rim2
D 1	on	380	Dr SdGM
D#1	on	358	Pc Clap
E 1	on	391	Dr SdWdH
F 1	on	409	Dr TomF
F#1	on	419	Dr HHC11
G 1	on	410	Dr TomL
G#1	on	424	Dr HHPdl
A 1	on	410	Dr TomL
A#1	on	426	Dr HHOpn
B 1	on	411	Dr TomM
C 2	on	412	Dr TomHL
C#2	on	433	Dr Crash
D 2	on	413	Dr TomHH
D#2	on	429	Dr Ride
E 2	on	435	Dr China
F 2	on	431	Dr Cup
F#2	on	354	Pc Tmborn
G 2	on	434	Dr Crash2
G#2	on	453	Dr T8Cwbl
A 2	on	434	Dr Crash2
A#2	on	356	Pc VbSlp
B 2	on	449	Dr T8Crsh
C 3	on	336	Pc BongoH
C#3	on	335	Pc BongoL
D 3	on	339	Pc CngSlp
D#3	on	338	Pc CongaH
E 3	on	337	Pc CongaL
F 3	on	345	Pc TmblsH
F#3	on	344	Pc TmblsL
G 3	on	341	Pc AgogoL
G#3	on	341	Pc AgogoL
A 3	on	349	Pc Cabasa
A#3	on	352	Pc Maracs
B 3	on	359	Pc Whistl
C 4	on	359	Pc Whistl
C#4	on	343	Pc GiroCl
D 4	on	342	Pc GuiroL
D#4	on	350	Pc Claves
E 4	on	348	Pc Wdbclk
F 4	on	348	Pc Wdbclk
F#4	on	346	Pc CuicaL
G 4	on	347	Pc CuicaH
G#4	on	355	Pc TrangL
A 4	on	355	Pc TrangL
A#4	on	353	Pc Shaker
B 4	on	357	Pc JnglBl
C 5	on	360	Pc Bltree
C#5	on	477	Dr DstKik
D 5	on	477	Dr DstKik
D#5	on	477	Dr DstKik
E 5	on	477	Dr DstKik
F 5	on	477	Dr DstKik
F#5	on	477	Dr DstKik
G 5	on	477	Dr DstKik
G#5	on	477	Dr DstKik
A 5	on	477	Dr DstKik
A#5	on	477	Dr DstKik
B 5	on	477	Dr DstKik
C 6	on	477	Dr DstKik

ウェーブリスト

No.	Cat./WaveName	No.	Cat./WaveName	No.	Cat./WaveName	No.	Cat./WaveName	No.	Cat./WaveName	No.	Cat./WaveName	No.	Cat./WaveName
1	Pf Grand	86	Or D1 1/3	171	Gt Single	256	Wv MogBs2	341	Pc AgogoL	426	Dr HHOpn	511	Pf Rho5M-
2	Pf Grand+	87	Or D1	172	Gt SnglHi	257	Wv MogBs3	342	Pc GuiroL	427	Dr HHOpn2	512	Pf Rho5L-
3	Pf Grand-	88	Or LesGrt	173	Gt StrfF	258	Wv FMBs1	343	Pc GiroCl	428	Dr HHTip	513	Pf Rho6H
4	Pf Brit	89	Or LesGr2	174	Gt ES335	259	Wv FMBs2	344	Pc TmbIsL	429	Dr Ride	514	Pf Rho6L
5	Pf Brit+	90	Or Rotar	175	Gt DistCl	260	Wv FMBs3	345	Pc TmbIsH	430	Dr Ride2	515	Pf Rho6H+
6	Pf Brit-	91	Or Clack	176	Gt DistMt	261	Wv FMBs4	346	Pc Cuical	431	Dr Cup	516	Pf Rho6L+
7	Pf CP80	92	Or LesWho	177	Gt FeedBk	262	Wv FMBs5	347	Pc CuicaH	432	Dr Cup2	517	Pf Rho6H-
8	Pf CP80+	93	Or SftTmp	178	Gt StlHrm	263	Wv FMBs6	348	Pc WdbIck	433	Dr Crash	518	Pf Rho6L-
9	Pf CP80-	94	Or Perc	179	Gt StrHrm	264	Wv FMFnk	349	Pc Cabasa	434	Dr Crash2	519	Or Pipe1St
10	Pf Rho1P	95	Or Perc+	180	Gt Dist2	265	Wv FMGr	350	Pc Claves	435	Dr China	520	Or Pipe1L
11	Pf Rho1P+	96	Or Perc-	181	Ba Acstic	266	Wv Late-S	351	Pc Castnt	436	Dr China2	521	Or Pipe1R
12	Pf Rho1P-	97	Or Harmnc	182	Ba Acstc+	267	Wv Late-L	352	Pc Maracs	437	Dr T8BdBm	522	Or Pipe2
13	Pf Rho1L	98	Or Acrdn	183	Ba Acstc-	268	Wv P5Saw	353	Pc Shaker	438	Dr T8Bd	523	Or Pipe3St
14	Pf Rho1L+	99	Or Acrdn+	184	Ba Fing	269	Wv Saw2	354	Pc Tmborn	439	Dr T8SD1	524	Or Pipe3L
15	Pf Rho1L-	100	Or Acrdn-	185	Ba Fing+	270	Wv 1o1Saw	355	Pc TrngL	440	Dr T8SD2	525	Or Pipe3R
16	Pf Rho2S	101	Cp FngCym	186	Ba Fing-	271	Wv 1o1Sub	356	Pc VbSlp	441	Dr T8SD3	526	Or Pipe4
17	Pf Rho2S+	102	Cp Hibasi	187	Ba Harmnc	272	Wv SawSqu	357	Pc JnglBl	442	Dr T8SD4	527	Or Pipe5
18	Pf Rho2S-	103	Cp StoneH	188	Ba Precsn	273	Wv SquSaw	358	Pc Clap	443	Dr T8Sde	528	Or Pipe6
19	Pf Rho2M	104	Cp StoneS	189	Ba Prcsn+	274	Wv MgRamp	359	Pc Whistl	444	Dr T8Rmst	529	Or Pipe7
20	Pf Rho2M+	105	Cp Gamln1	190	Ba Pecsn-	275	Wv P10-1	360	Pc Bltree	445	Dr T8Clap	530	En AahSt
21	Pf Rho2M-	106	Cp Gamln2	191	Ba PrsRw	276	Wv P10-2	361	Pc AnvlHt	446	Dr T8Tom	531	En AahL
22	Pf Rho2H	107	Cp Glock	192	Ba PrsRw+	277	Wv P10-3	362	Pc AnvlPp	447	Dr T8HHCl	532	En AahR
23	Pf Rho2H+	108	Cp Marimb	193	Ba PrsRw-	278	Wv P25-1	363	Pc Scrch1	448	Dr T8HHOp	533	En AahC
24	Pf Rho2H-	109	Cp Vibra	194	Ba Pick	279	Wv P25-2	364	Pc Scrch2	449	Dr T8Crsh	534	En AahSt+
25	Pf Rho3	110	Cp Xylo	195	Ba Slap	280	Wv P50-1	365	Pc VoxDrm	450	Dr T8CngL	535	En AahL+
26	Pf Rho3+	111	Cp HndBel	196	Ba Slap+	281	Wv P50-2	366	Pc Ripper	451	Dr T8CngM	536	En AahR+
27	Pf Rho3-	112	Cp Crotls	197	Ba Slap-	282	Wv Tri	367	Pc CONG	452	Dr T8CngH	537	En AahC+
28	Pf Rho4	113	Cp Timpni	198	Ba Slap2	283	Wv Digi01	368	Pc StlClp	453	Dr T8Cwbl	538	En AahSt-
29	Pf Rho4+	114	Br SectnL	199	Ba Slap2+	284	Wv Digi02	369	Pc WdBlk	454	Dr T8Clve	539	En AahL-
30	Pf Rho4-	115	Br SectnR	200	Ba Slap2-	285	Wv Digi03	370	Dr BdStd	455	Dr T8MrCs	540	En AahR-
31	Pf Wurl1	116	Br SctnSt	201	Ba Frtl1	286	Wv Digi04	371	Dr BdPop	456	Dr T9BD1	541	En AahC-
32	Pf Wurl1+	117	Br SctnL-	202	Ba Frtl1+	287	Wv Digi05	372	Dr BdHby	457	Dr T9BD2	542	En OohSt
33	Pf Wurl1-	118	Br SctnR-	203	Ba Frtl1-	288	Wv Digi06	373	Dr BdLoJz	458	Dr T9BD3	543	En OohL
34	Pf DX1	119	Br SctSt-	204	Ba Frtl2	289	Wv Digi07	374	Dr BdVar1	459	Dr T9SD1	544	En OohR
35	Pf DX2	120	Br Sctn2L	205	Ba Frtl2+	290	Wv Digi08	375	Dr BdVar2	460	Dr T9SD2	545	En OohRich
36	Pf DX3	121	Br Sctn2R	206	Ba Frtl2-	291	Wv Digi09	376	Dr BdVar3	461	Dr T9SD3	546	En OohSt+
37	Pf Clav1	122	Br Sct2St	207	Ba SyBass	292	Wv Digi10	377	Dr BdVar4	462	Dr T9SD4	547	En OohL+
38	Pf Clav1+	123	Br Sct2L+	208	En SynVox	293	Wv Digi11	378	Dr BdVar5	463	Dr T9SD5	548	En OohR+
39	Pf Clav1-	124	Br SctnR+	209	En VxNoiz	294	Wv Digi12	379	Dr BdAna	464	Dr T9SD6	549	En OohRich+
40	Pf Clav2	125	Br Sct2S+	210	En Aah	295	Wv Bel1Wv	380	Dr SdGM	465	Dr T9Clap	550	En OohSt-
41	Pf Clav2+	126	Br Sct2L-	211	En Aah+	296	Wv Bel2Wv	381	Dr SdBldS	466	Dr T9Rim	551	En OohL-
42	Pf Clav2-	127	Br Sct2R-	212	En Aah-	297	Wv DgVox1	382	Dr SdBldH	467	Dr T9TomL	552	En OohR-
43	Pf Clav3	128	Br Sct2S-	213	En Oooo	298	Wv DgVox2	383	Dr SdFsnH	468	Dr T9TomM	553	En OohRich-
44	Pf Clav3+	129	Br Trmbn	214	En Oooo+	299	Wv DgVox3	384	Dr SdLdwH	469	Dr T9TomH		
45	Pf Clav3-	130	Br Trmbn-	215	En Oooo-	300	Wv DgVox4	385	Dr SdSonA	470	Dr T9HHC1		
46	Pf Hrpsc	131	Br SftTrb	216	En Itopia	301	Wv DgVox5	386	Dr SdSonD	471	Dr T9HHC2		
47	Or JmPrc	132	Br SftFlg	217	Rd Alto	302	Wv VoxG2	387	Dr SdHvy	472	Dr T9HHO1		
48	Or JmPrc-	133	Br SftFl-	218	Rd Alto+	303	Wv VoxE3	388	Dr SdPclH	473	Dr T9HHO2		
49	Or Jazz	134	Br Hermn	219	Rd Alto-	304	Wv Ep1	389	Dr SdPcBH	474	Dr T9Crsh		
50	Or Jazz+	135	Br Strgt	220	Rd Tenor	305	Wv Ep2	390	Dr SdPrmH	475	Dr T9Ride		
51	Or Jazz-	136	Br TrpMed	221	Rd Tenor+	306	Wv Ep3	391	Dr SdWdH	476	Dr EuroBD		
52	Or Rock	137	Br TrpSft	222	Rd Tenor-	307	Wv Ep4	392	Dr SdVar1	477	Dr DstKik		
53	Or Rock+	138	Br Trmpt	223	Rd Bari	308	Wv Ep5	393	Dr SdVar2	478	Dr Bd Kit		
54	Or Rock-	139	Br Trmpt+	224	Rd BigSx1	309	Wv EP6	394	Dr SdRim1	479	Dr Sn Kit		
55	Or Argent	140	Br Trmpt-	225	Rd BigSx2	310	Wv Org1Wv	395	Dr SdRim2	480	Pf Grand2		
56	Or BowVb	141	Br PiclTp	226	Rd SxBth	311	Wv Org2Wv	396	Dr SdAmb1	481	Pf Grand2St		
57	Or BowNv	142	Br F.Horn	227	Rd Soprn	312	Wv Org3Wv	397	Dr SdAmb2	482	Pf Grand2L		
58	Or Gospel	143	Br Combi1	228	Rd Soprn+	313	Wv Sin	398	Dr SdAmb3	483	Pf Grand2R		
59	Or Green	144	Br Combi2	229	Rd Soprn-	314	Wv Noise	399	Dr SdBkbt	484	Pf Grand2+		
60	Or Santana	145	Br Combi3	230	Rd Clari	315	Wv PhnNP	400	Dr SdDry	485	Pf Grnd2St+		
61	Or Farfis	146	Br Combi4	231	Rd Clari+	316	Wv EPNP	401	Dr SdSwep	486	Pf Grand2L+		
62	Or Farf-	147	St Vln	232	Rd Clari-	317	Wv VibeNP	402	Dr SdBrsS	487	Pf Grand2R+		
63	Or VoxOrg	148	St Vln2	233	Rd Oboe	318	Fx VoxBel	403	Dr SdBrsH	488	Pf Grand2-		
64	Or VxOrg-	149	St Cello	234	Rd Oboe+	319	Fx Melow	404	Dr SdBrsL	489	Pf Grnd2St-		
65	Or Swish	150	St EnsMx	235	Rd Oboe-	320	Fx WndChm	405	Dr SdRoll	490	Pf Grand2L-		
66	Or Swish-	151	St EnsMx-	236	Rd Basoon	321	Fx BelAir	406	Dr C.Rim1	491	Pf Grand2R-		
67	Or Dw1+3	152	St SmlEns	237	Rd Basoon+	322	Fx BigSyn	407	Dr C.Rim2	492	Pf Grand3		
68	Or Dw1+3+	153	St SmlEn+	238	Rd Basoon-	323	Fx TrnCho	408	Dr Stick	493	Pf Grand3St		
69	Or Dw1+3-	154	St SmlEn-	239	Pi Flute	324	Fx HanSol	409	Dr TomF	494	Pf Grand3L		
70	Or Dw2+4	155	St Pizz	240	Pi Flute+	325	Fx Eery	410	Dr TomL	495	Pf Grand3R		
71	Or Dw2+4+	156	St Pizz2	241	Pi Flute-	326	Fx Electr	411	Dr TomM	496	Pf Grand3+		
72	Or Dw2+4-	157	St Harp	242	Pi PnFlt	327	Fx HH Hit	412	Dr TomHL	497	Pf Grnd3St+		
73	Or DrwEv	158	Gt Nylon	243	Pi PnFlt-	328	Fx VxAlk	413	Dr TomHH	498	Pf Grand3L+		
74	Or DrwEv+	159	Gt NylNHi	244	Wv ModSaw	329	Fx HiLo	414	Dr TmJzL	499	Pf Grand3R+		
75	Or DrwEv-	160	Gt NylHrm	245	Wv ObStr	330	Fx MltPno	415	Dr TmJzM	500	Pf Grand3-		
76	Or DrwOd	161	Gt Steel	246	Wv JpStr	331	Fx AHoseL	416	Dr TmJzH	501	Pf Grnd3St-		
77	Or DrwOd+	162	Gt StelHi	247	Wv SyzStr	332	Fx AHoseR	417	Dr Tom2H	502	Pf Grand3L-		
78	Or DrwOd-	163	Gt StelLo	248	Wv Padd	333	Et StlDrm	418	Dr Tom2L	503	Pf Grand3R-		
79	Or D16	164	Gt JzGr	249	Wv ObBrs	334	Et Sitar	419	Dr HHCl1	504	Pf Rho5H		
80	Or D5 1/3	165	Gt Strt	250	Wv SyncLd	335	Pc BongoL	420	Dr HHCL2	505	Pf Rho5M		
81	Or D8	166	Gt StrtN	251	Wv CS80Br	336	Pc BongoH	421	Dr HHCl3	506	Pf Rho5L		
82	Or D4	167	Gt StrtSI	252	Wv 3o3Saw	337	Pc CongaL	422	Dr HHCl4	507	Pf Rho5H+		
83	Or D2 2/3	168	Gt StrtSp	253	Wv 3o3Sw2	338	Pc CongaH	423	Dr HHCl5	508	Pf Rho5M+		
84	Or D2	169	Gt StrtMt	254	Wv 3o3Squ	339	Pc CngSlp	424	Dr HHPdl	509	Pf Rho5L+		
85	Or D1 3/5	170	Gt Front	255	Wv MogBs1	340	Pc Cowbel	425	Dr HHPdl2	510	Pf Rho5H-		

パフォーマンスリスト

Internal (MSB=63, LSB=64)

No.	Performance Name	Category	Notes
1(A01)	AGE2000NEW	Co	●
2(A02)	Hallelujah	Vo	
3(A03)	MetalPiano	Pf	
4(A04)	MayanMagic	Fx	
5(A05)	HipHop Pop	Co	●
6(A06)	Oktavian	Sc	
7(A07)	Bass/Piano	Co	
8(A08)	Overture	Fx	
9(A09)	Opus 12	St	
10(A10)	EP+Strings	Co	
11(A11)	MuteTrp/EP	Co	
12(A12)	Rock It!	Co	●
13(A13)	WhirlPool	Fx	
14(A14)	Marrakesh	Et	●
15(A15)	SuperStrgs	St	
16(A16)	Mysterioso	Pd	
17(B01)	Clockworks	Se	
18(B02)	ChurchEns	Co	
19(B03)	TX816 EP	Pf	
20(B04)	Neonist	Co	
21(B05)	Busta'	Co	●
22(B06)	Trancitar	Co	
23(B07)	Bss/Pno+EP	Co	
24(B08)	CirqDeAna	Co	●
25(B09)	ScratchIt	Co	●
26(B10)	EP/Strings	Co	
27(B11)	Sax/EP	Co	
28(B12)	Rollin'	Co	●
29(B13)	GuitInAPad	Co	
30(B14)	SafariTech	Et	●
31(B15)	Classical1	Co	
32(B16)	Horror	Se	*1参照
33(C01)	Dreamloopr	Co	●
34(C02)	Messiah	Co	
35(C03)	CrystalPno	Pf	
36(C04)	Pad Sweep	Pd	
37(C05)	Ottomatic	Co	●
38(C06)	Rockie	Sc	
39(C07)	Club Blues	Co	
40(C08)	Drumantics	Dr	●
41(C09)	Fairy Dust	Co	
42(C10)	Piano&Str.	Co	
43(C11)	Bavarian	Co	
44(C12)	SlowGroove	Co	●
45(C13)	Bell&Str	Co	
46(C14)	Rezzies	Co	●
47(C15)	Classical2	Co	
48(C16)	911 Call	Se	
49(D01)	Seekwencer	Co	●
50(D02)	Sanctuary	Co	
51(D03)	Wire+Piano	Pf	
52(D04)	DeepBreeze	Pd	
53(D05)	DiscoDucks	Co	●
54(D06)	BigFive	Sc	
55(D07)	Bs/PercOrg	Co	
56(D08)	Night Byte	Sq	
57(D09)	Sonority	Co	
58(D10)	Folk Trio	Co	
59(D11)	Funk It!	Co	
60(D12)	Police Men	Co	●
61(D13)	2 Mini's	Ld	
62(D14)	Aquamarine	Co	●
63(D15)	Classical3	Co	
64(D16)	Nitechills	Se	

No.	Performance Name	Category	Notes
65(E01)	RayOfLight	Co	●
66(E02)	NotreDame	Co	
67(E03)	Montuno	Pf	
68(E04)	80Sphere	Pd	
69(E05)	TheIslands	Co	●
70(E06)	SweepPerf	Sc	
71(E07)	Jazz It!	Co	
72(E08)	Mobutu	Se	●
73(E09)	Harp@Orch	Co	
74(E10)	PF/Strings	Co	
75(E11)	Gnu Age	Co	
76(E12)	Cookin'	Co	●
77(E13)	A.Gt/Lucky	Co	
78(E14)	PhazeEuro	Co	●
79(E15)	Classical4	Co	
80(E16)	Scare-isma	Fx	*1参照
81(F01)	Shagundala	Co	●
82(F02)	Sevenths	Br	
83(F03)	BreathPian	Pf	
84(F04)	It Grows!	Pd	
85(F05)	Flute Funk	Co	
86(F06)	Real World	Co	
87(F07)	Cool Vibe	Co	
88(F08)	Paradise	Co	●
89(F09)	Balladeer	Co	●
90(F10)	Strg/Piano	Co	
91(F11)	Barcelona	Co	●
92(F12)	Girl	Co	●
93(F13)	1973!	Co	
94(F14)	Flying	Co	●
95(F15)	Classical5	Co	
96(F16)	PatchCords	Fx	
97(G01)	Pops	--	
98(G02)	Ballad 1	--	
99(G03)	Ballad 2	--	
100(G04)	Unplugged	--	
101(G05)	80's Disco	--	
102(G06)	Funk Rock	--	
103(G07)	Hard Rock	--	
104(G08)	HeavyMetal	--	
105(G09)	ProgreRock	--	
106(G10)	Blues Rock	--	
107(G11)	West Coast	--	
108(G12)	BritishRck	--	
109(G13)	Big Band	--	
110(G14)	Combo Jazz	--	
111(G15)	JazzBallad	--	*2参照
112(G16)	Fusion	--	
113(H01)	Club Jazz	--	
114(H02)	House	--	
115(H03)	Techno	--	
116(H04)	Trance	--	
117(H05)	Big Beat	--	
118(H06)	Drum'nBass	--	
119(H07)	HipHop	--	
120(H08)	Reggae	--	
121(H09)	R&B	--	
122(H10)	India	--	
123(H11)	Salsa	--	
124(H12)	Gamelan	--	
125(H13)	Ambient	--	
126(H14)	Tango	--	
127(H15)	SoundTrack	--	
128(H16)	Master KB	--	*3参照

*1 鍵盤での演奏に適したパフォーマンス

*2 シーケンサーでのマルチパート再生に適したパフォーマンス

*3 マスターキーボード機能の設定に適したパフォーマンス

はアルペジオホールド機能が設定されているパフォーマンスです。
ノブ2を左に回すと、アルペジオをオフにできます。

コントロールリスト

コントロールセットデスティネーションパラメーター

No.	LCD	パラメーター
00	off	:off
01	Volume	Voice Volume
02	RevSend	Reverb Send
03	ChoSend	Chorus Send
04	INS1-P1:EF1	Insertion Effect 1 Parameter 1
:	:	:
13	INS1P10:EF1	Insertion Effect 1 Parameter 10
14	INS2-P1:EF2	Insertion Effect 2 Parameter 1
:	:	:
29	INS2P16:EF2	Insertion Effect 2 Parameter 16
30	CLFOSpd	Common LFO Speed
31	CLFO-D1	Common LFO Depth1
32	CLFO-D2	Common LFO Depth2
33	PorTime	Common Portamento Time
34	ELM-Lvl	Element Level
35	ELM-Pan	Element Pan
36	ELM-Dly	Element Key On Delay
37	ELFOSpd	Element LFO Speed
38	ELFO-PM	Element LFO Pitch Modulation Depth
39	ELFO-AM	Element LFO Amplitude Modulation Depth
40	ELFO-FM	Element LFO Filter Modulation Depth
41	PCH-Crs	Element Pitch Coarse
42	PCH-Fin	Element Pitch Fine
43	PEG-Dpt	Element Pitch EG Depth
44	PEG-Hld	Element Pitch EG Hold Time
45	PEG-Atk	Element Pitch EG Attack Time
46	PEG-D1	Element Pitch EG Decay1 Time
47	PEG-D2	Element Pitch EG Decay2 Time
48	PEG-Rel	Element Pitch EG Release Time
49	AEG-Atk	Element Amplitude EG Attack Time
50	AEG-D1	Element Amplitude EG Decay1 Time
51	AEG-D2	Element Amplitude EG Decay2 Time
52	AEG-Rel	Element Amplitude EG Release Time
53	FEG-Dpt	Element Filter EG Depth
54	FEG-Hld	Element Filter EG Hold Time
55	FEG-Atk	Element Filter EG Attack Time
56	FEG-D1	Element Filter EG Decay1 Time
57	FEG-D2	Element Filter EG Decay2 Time
58	FEG-Rel	Element Filter EG Release Time
59	FLT-Frq	Element Filter Cutoff Frequency
60	FLT-Rez	Element Filter Resonance
61	HPF-Frq	Element Filter HPF Cutoff Frequency

00 - 29 は、すべてのコントロールセットで使用できます。ただし、プラグインボイスの場合は 00 - 13 のパラメーターに限られます。
 30 - 61 は、プラグインボイスを除くノーマルボイスで使用できます。
 04 - 29 は、インサージョンエフェクトが割り当てられている場合のみ使用でき、そのエフェクトタイプによって有効なパラメーターが限られます。デスティネーションが有効なパラメーターの場合は、上記の "INS1P10" などの部分にそのパラメーター名が表示されます。有効なパラメーターでない場合は、コントロールセット画面では上記の表示に、プレイ画面では "-----" の表示になります。

システムコントローラーデスティネーションパラメーター

No.	LCD	パラメーター
00	off	off
01	EQLow-G	MEQ Low Gain
02	EQLow-F	MEQ Low Frequency
03	EQLow-Q	MEQ Low Q
04	EQLoM-G	MEQ Low Mid Gain
05	EQLoM-F	MEQ Low Mid Frequency
06	EQLoM-Q	MEQ Low Mid Q
07	EQMid-G	MEQ Mid Gain
08	EQMid-F	MEQ Mid Frequency
09	EQMid-Q	MEQ Mid Q
10	EQHiM-G	MEQ High Mid Gain
11	EQHiM-F	MEQ High Mid Frequency
12	EQHiM-Q	MEQ High Mid Q
13	EQHi-G	MEQ High Gain
14	EQHi-F	MEQ High Frequency
15	EQHi-Q	MEQ High Q
16	REV-P1	ReverbParameter 1
:	:	:
25	REV-P10	Reverb Parameter 10
26	REV-Rtn	Reverb Return
27	REV-Pan	Reverb Pan
28	CHO-P1	Chorus Parameter 1
:	:	:
37	CHO-P10	Chorus Parameter 10
38	CHO-Rtn	Chorus Return
39	CHO-Pan	Chorus Pan
40	Cho>Rev	Send Chorus To Reverb
41	ARP-Typ	Arpeggio Type
42	ARP-Unt	Arpeggio Unit Multiply
43	ARP-Vel	Arpeggio Velocity Rate
44	ARP-Gat	Arpeggio Gate Time Rate
45	Tempo	Arpeggio/Sequencer Tempo
46	EG-Atck	QED EG Attack Time
47	EG-Decy	QED EG Decay Time
48	EG-SusL	QED EG Sustain Level
49	EG-Rele	QED EG Release Time
50	Cutoff	QED Cutoff Frequency
51	Reso	QED Resonance

16 - 25、28 - 37 は、そのエフェクトタイプによって有効なパラメーターが限られます。デスティネーションが有効なパラメーターの場合は、上記の "REV-P10" などの部分にそのパラメーター名が表示されます。有効なパラメーターでない場合は、コントローラー画面では上記の表示に、プレイ画面では "-----" の表示になります。

アルペジオタイプリスト

コントロールチェンジナンバーリスト

【CONTROLLER】

Name	No.	備考
PB:PITCH BEND		Pitch Bend
MW:MODULATION WHELL	1	Modulation
AT:AFTER TOUCH		After Touch
BC:BREATH CONTROLLER	(2)	ユーティリティ/パフォーマンスで設定
RB:RIBBON CONTROLLER	(22)	ユーティリティ/パフォーマンスで設定
FC:FOOT CONTROLLER	(11)	ユーティリティ/パフォーマンスで設定
FS:FOOT SWITCH	(64)	ユーティリティで設定

【ASSIGNABLE KNOB】

Name	No.	備考
[KNOB A]	(18)	ユーティリティで設定
[KNOB B]	(19)	ユーティリティで設定
[KNOB C]	(20)	ユーティリティで設定
[KNOB 1]	(16)	ユーティリティ/パフォーマンスで設定
[KNOB 2]	(17)	ユーティリティ/パフォーマンスで設定

() の付いたコントロールチェンジナンバーは初期値。

No.	Name	No.	Name
1	UpOct1:Sq	65	SuperArp:Ph
2	UpOct2:Sq	66	MuteArp1:Ph
3	UpOct4:Sq	67	MuteArp2:Ph
4	DownOct1:Sq	68	VelGruv1:Ph
5	DownOct2:Sq	69	VelGruv2:Ph
6	DownOct4:Sq	70	SpaceArp:Ph
7	U/DAOct1:Sq	71	Muteline:Ph
8	U/DAOct2:Sq	72	StepLine:Ph
9	U/DAOct4:Sq	73	AcidLine:Ph
10	U/DBOct1:Sq	74	SplitArp:Ph
11	U/DBOct2:Sq	75	Step Seq:Ph
12	U/DBOct4:Sq	76	PolyArp1:Ph
13	RndmOct1:Sq	77	PolyArp2:Ph
14	RndmOct2:Sq	78	Ana Seq:Ph
15	RndmOct4:Sq	79	Planet:Ph
16	Oct2Up:Sq	80	Rosync:Ph
17	Oct4Up:Sq	81	StrumArp:Ph
18	UnisonUp:Sq	82	Guit1Arp:Ph
19	Up&Down1:Sq	83	RolliArp:Ph
20	Up&Down2:Sq	84	Guit2Arp:Ph
21	Up&Down4:Sq	85	Guit3Arp:Ph
22	Up&Alt1:Sq	86	Guit4Arp:Ph
23	Up&Rndm1:Sq	87	Harp Arp:Ph
24	Up&Rndm2:Sq	88	BigBeat1:Dr
25	Up&Rndm4:Sq	89	BigBeat2:Dr
26	ChdAltB1:Sq	90	BigBeat3:Dr
27	ChdAltB2:Sq	91	BigBeat4:Dr
28	ChdAltB4:Sq	92	Rock1:Dr
29	ChdRndm1:Sq	93	Rock2:Dr
30	ChdRndm2:Sq	94	Rock3:Dr
31	ChdRndm4:Sq	95	BigBeat5:Dr
32	TechnoA:Ph	96	BigBeat6:Dr
33	TechnoB:Ph	97	BigBeat7:Dr
34	TechnoC:Ph	98	BigBeat8:Dr
35	DAHouse:Ph	99	BigBeat9:Dr
36	SyncopaA:Ph	100	BrkTrnce:Dr
37	SyncopaB:Ph	101	House1:Dr
38	SyncpEco:Ph	102	House2:Dr
39	TekEchoA:Ph	103	House3:Dr
40	TekEchoB:Ph	104	Garage:Dr
41	PulsLine:Ph	105	House4:Dr
42	SeqS&H1:Ph	106	House5:Dr
43	SeqS&H2:Ph	107	HipHop:Dr
44	CleanGt1:Ph	108	JazzHop:Dr
45	CleanGt2:Ph	109	Abstract:Dr
46	CleanGt3:Ph	110	LoBeat1:Dr
47	CleanGt4:Ph	111	LoBeat2:Dr
48	Pno16Bt:Ph	112	LoBeat3:Dr
49	PnoLatin:Ph	113	LoBeat4:Dr
50	CrvBass:Ph	114	LoBeat5:Dr
51	Ocean:Ph	115	LoBeat6:Dr
52	Orbit:Ph	116	Drm&Bs1:Dr
53	X-Sweep1:Ph	117	Drm&Bs2:Dr
54	X-Sweep2:Ph	118	Linear:Dr
55	X-Sweep3:Ph	119	08beat1:Dr
56	Lamb:Ph	120	08beat2:Dr
57	Thips:Ph	121	08beat3:Dr
58	Hardcore:Ph	122	16beat1:Dr
59	Harmo:Ph	123	16beat2:Dr
60	Ascorbic:Ph	124	1Bar:Dr
61	Doves:Ph	125	1BarRndm:Dr
62	Chodal:Ph	126	GateCut1:Ct
63	Simple:Ph	127	GateCut2:Ct
64	Waggle:Ph	128	GateCut3:Ct

エフェクトタイプリスト

Effect Category	Effect Name	LCD	MIDI (HEX)		No.			
			MSB	LSB	REV	CHO	InsEF1	InsEF2
---	NO EFFECT	off	00	00	0	0		
---	THRU	Thru	00	00			0	0
REVERB								
REV	HALL 1	Hall1	01	00	1			1
REV	HALL 2	Hall2	01	01	2			2
REV	ROOM 1	Room1	01	10	3			3
REV	ROOM 2	Room2	01	11	4			4
REV	ROOM 3	Room3	01	12	5			5
REV	STAGE 1	Stage1	01	20	6			6
REV	STAGE 2	Stage2	01	21	7			7
REV	PLATE	Plate	01	30	8			8
REV	WHITE ROOM	WhiteRm	01	40	9			
REV	TUNNEL	Tunnel	01	41	10			
REV	BASEMENT	Basement	01	42	11			
REV	CANYON	Canyon	01	43	12			
DELAY								
DLY	DELAY L.C.R	DelayLCR	02	00				9
DLY	DELAY L.R	DelayLR	02	10		18		10
DLY	ECHO	Echo	02	20				11
DLY	CROSS DELAY	CrossDly	02	30				12
DLY	CONTROL DELAY1 (MONO)	CtrlDly1	02	40		19		13
DLY	CONTROL DELAY2 (STEREO)	CtrlDly2	02	48		20		14
DLY	TEMPO DELAY1 (MONO)	TempDly1	02	50		21		15
DLY	TEMPO DELAY2 (STEREO)	TempDly2	02	58		22		16
DLY	TEMPO CROSS DELAY	TempCDly	02	60		23		17
EARLY REFLECTION								
ER	EARLY REFLECTION 1	ER 1	03	00				18
ER	EARLY REFLECTION 2	ER 2	03	01				19
ER	GATE REVERB	GateRev	03	10				20
ER	REVERSE GATE	RvrsGate	03	20				21
KARAOKE								
KAR	KARAOKE 1	Karaoke1	04	00				22
KAR	KARAOKE 2	Karaoke2	04	01				23
KAR	KARAOKE 3	Karaoke3	04	02				24
CHORUS								
CHO	CHORUS 1	Chorus1	05	00	1	1		25
CHO	CHORUS 2	Chorus2	05	01	2	2		26
CHO	CHORUS 3	Chorus3	05	02	3	3		27
CHO	CHORUS 4	Chorus4	05	08	4	4		28
CHO	CHORUS 5	Chorus5	05	09	5	5		29
CHO	CELESTE 1	Celeste1	05	10	6	5		30
CHO	CELESTE 2	Celeste2	05	11	7	6		31
CHO	CELESTE 3	Celeste3	05	12	8	7		32
CHO	CELESTE 4	Celeste4	05	18	9	8		33
CHO	SYMPHONIC	Symphonic	05	20		10		34
CHO	ENSEMBLE DETUNE	Ensemble	05	30		11		35
FLANGER								
FLG	FLANGER 1	Flanger1	06	00		12	9	36
FLG	FLANGER 2	Flanger2	06	01		13	10	37
FLG	FLANGER 3	Flanger3	06	08		14	11	38
FLG	V-FLANGER	V-Flange	06	10				39
FLG	TEMPO FLANGER	TempFlng	06	50		15		40
PHASER								
PHA	PHASER 1	Phaser1	07	00		16	12	41
PHA	PHASER 2	Phaser2	07	08				42
PHA	TEMPO PHASER	TempPhas	07	50		17		43
MODULATION								
MOD	TREMOLO	Tremolo	08	00			13	44
MOD	AUTO PAN	AutoPan	08	10			14	45
MOD	ROTARY SPEAKER1	RotrySp1	08	50				46
MOD	DISTORTION+ROTARY SPEAKER1	Dt+RSp1	08	51				47
MOD	OVERDRIVE+ROTARY SPEAKER1	Od+RSp1	08	52				48
MOD	AMP SIM.+ROTARY SPEAKER1	Amp+RSp1	08	53				49
MOD	ROTARY SPEAKER2	RotrySp2	08	60				50
MOD	DISTORTION+ROTARY SPEAKER2	Dt+RSp2	08	61				51
MOD	OVERDRIVE+ROTARY SPEAKER2	Od+RSp2	08	62				52
MOD	AMP SIM.+ROTARY SPEAKER2	Amp+RSp2	08	63				53
MOD	ROTARY SPEAKER3	RotrySp3	08	70				54
MOD	ROTARY SPEAKER4	RotrySp4	08	71				55
DISTORTION								
DST	DISTORTION	Dist	09	00			15	56
DST	COMP DISTORTION	CompDt	09	01				57
DST	V-DISTORTION	V-Dist	09	10				58
DST	OVER DRIVE	OverDrv	09	20			16	59
DST	AMP SIMULATOR	AmpSim	09	30				60
DST	DIST+DELAY	Dist+Dly	09	40				61
DST	OVERDRIVE+DELAY	Odrv+Dly	09	41				62
DYNAMIC								
DYN	COMPRESSOR1	Comp1	0A	00			18	63
DYN	NOISE GATE	NoisGate	0A	20			19	64
DYN	COMP+DIST+DELAY	CmpDlDly	0A	40				65
DYN	COMP+OVERDRIVE+DELAY	CmpOdDly	0A	41				66
PITCH CHANGE								
PCH	PITCH CHANGE 1	PchChng1	0B	00				67
PCH	PITCH CHANGE 2	PchChng2	0B	01				68
WAH								
WAH	AUTO WAH	AutoWah	0C	00			20	69
WAH	AUTO WAH + DIST	AWah+Dt	0C	01				70
WAH	AUTO WAH + OVERDRIVE	AWah+Od	0C	02				71
WAH	TOUCH WAH	TouchWah	0C	10			21	72
WAH	TOUCH WAH + DIST	TWah+Dt	0C	11				73
WAH	TOUCH WAH + OVERDRIVE	TWah+Od	0C	12				74
WAH	WAH+DIST+DELAY	WahDtDly	0C	40				75
WAH	WAH+OVERDRIVE+DELAY	WahOdDly	0C	41				76
LO-FI								
L-F	LO-FI	Lo-Fi	0D	00				77
L-F	LOW RESOLUTION	LowReso	0D	10				78
L-F	NOISY	Noisy	0D	20				79
L-F	ATTACK LOFI	AtkLoFi	0D	30				80
L-F	DIGITAL TURNTABLE	DTurnTbl	0D	50				81
TECH								
TEC	DIGITAL SCRATCH	DScratch	0E	00				82
TEC	AUTO SYNTH	AutoSyn	0E	10				83
TEC	TECH MODULATION	TechMod	0E	20				84
TEC	JUMP	Jump	0E	30				85
MISC								
MSC	3BAND EQ	3BandEQ	0F	00			22	86
MSC	2BAND EQ	2BandEQ	0F	01			23	87
MSC	HARMONIC ENHANCER	Enhancer	0F	10			24	88
MSC	VOICE CANCEL	VceCancel	0F	20				89
MSC	AMBIENCE	Ambience	0F	30				90
MSC	TALKING MODULATOR	TalkMod	0F	40				91
MSC	BEAT CHANGE	BeatChng	0F	50				92

エフェクトパラメーターリスト

1.Reverb

[1] HALL1 ~ [8] PLATE

No.	Parameter	Value	LCD	MIDI Parameter Number	Controller
1	Reverb Time	0.3s~30.0s	RevTime	1	
2	Initial Delay	0.1ms~200.0ms	InitDly	3	
3	Reverb Delay	0.1ms~200.0ms	RevDly	6	
4	HPF Cutoff Frequency	20Hz~8.0kHz	HPF	4	○
5	LPF Cutoff Frequency	1.0kHz~20.0kHz	LPF	5	○
6	Diffusion	0~10	Diffuse	2	
7	Density	0~4	Density	7	
8	ER / Rev Balance	E63>R - E=R - E<R63	ER/Rev	8	○
9	Feedback High Damp	0.1~1.0	FBHIDmp	9	
10	Feedback Level	-63~+63	FBLevel	10	○

[9] WHITE ROOM ~ [12] CANYON

No.	Parameter	Value	LCD	MIDI Parameter Number	Controller
1	Reverb Time	0.3s~30.0s	RevTime	1	
2	Initial Delay	0.1ms~200.0ms	InitDly	3	
3	Reverb Delay	0.1ms~200.0ms	RevDly	10	
4	HPF Cutoff Frequency	20Hz~8.0kHz	HPF	4	○
5	LPF Cutoff Frequency	1.0kHz~20.0kHz	LPF	5	○
6	Diffusion	0~10	Diffuse	2	
7	Width	0.5m~30.2m	Width	6	
8	Height	0.5m~30.2m	Height	7	
9	Depth	0.5m~30.2m	Depth	8	
10	Wall Vary	0~30	Wall	9	

2.Chorus

[1] CHORUS1~[5] CHORUS5

はChorus Controlで変更されるパラメーター

[6] CELESTE1~[9] CELESTE4

No.	Parameter	Value	LCD	MIDI Parameter Number	Controller
1	LFO Frequency	0.0Hz~39.70Hz	Speed	1	○
2	LFO Depth	0~127	Depth	2	◎
3	EQ Low Frequency	32Hz~2.0kHz	L.Freq	5	○
4	EQ Low Gain	-12dB~+12dB	L.Gain	6	○
5	EQ High Frequency	500Hz~6.0kHz	H.Freq	7	○
6	EQ High Gain	-12dB~+12dB	H.Gain	8	○
7	Delay Offset	0.0ms~50.0ms	DlyOfst	4	
8	Feedback Level	-63~+63	FBLevel	3	○

[10] SYMPHONIC

No.	Parameter	Value	LCD	MIDI Parameter Number	Controller
1	LFO Frequency	0.0Hz~39.70Hz	Speed	1	○
2	LFO Depth	0~127	Depth	2	◎
3	Delay Offset	0.0ms~50.0ms	DlyOfst	3	
4	EQ Low Frequency	32Hz~2.0kHz	L.Freq	4	○
5	EQ Low Gain	-12dB~+12dB	L.Gain	5	○
6	EQ High Frequency	500Hz~16.0kHz	H.Freq	6	○
7	EQ High Gain	-12dB~+12dB	H.Gain	7	○

[11] ENSEMBLE DETUNE

No.	Parameter	Value	LCD	MIDI Parameter Number	Controller
1	Detune	-50cent~+50cent	Detune	1	◎
2	Initial Delay Lch	0.0ms~50.0ms	DelayL	2	
3	Initial Delay Rch	0.0ms~50.0ms	DelayR	3	

[12] FLANGER1 ~ [14] FLANGER3

No.	Parameter	Value	LCD	MIDI Parameter Number	Controller
1	LFO Frequency	0.0Hz~39.70Hz	Speed	1	◎
2	LFO Depth	0~127	Depth	2	○
3	LFO Phase Difference	-180deg~+180deg	Phase	5	
4	EQ Low Frequency	32Hz~2.0kHz	L.Freq	6	○
5	EQ Low Gain	-12dB~+12dB	L.Gain	7	○
6	EQ High Frequency	500Hz~16.0kHz	H.Freq	8	○
7	EQ High Gain	-12dB~+12dB	H.Gain	9	○
8	Delay Offset	0.0ms~50.0ms	DlyOfst	4	
9	Feedback Level	-63~+63	FBLevel	3	○

[15] TEMPO FLANGER

No.	Parameter	Value	LCD	MIDI Parameter Number	Controller
1	LFO Frequency	5-21	Speed	1	○
2	LFO Depth	0-127	Depth	2	◎
3	LFO Phase Difference	-180deg~+180deg	Phase	6	○
4	LFO Phase Reset	off/free run, Key/OnReset, SEQ Start Reset	Reset	5	○
5	EQ Low Frequency	32Hz~2.0kHz	L.Freq	7	○
6	EQ Low Gain	-12dB~+12dB	L.Gain	8	○
7	EQ High Frequency	500Hz~16.0kHz	H.Freq	9	○
8	EQ High Gain	-12dB~+12dB	H.Gain	10	○
9	Delay Offset	0.0ms~50.0ms	DlyOfst	4	○
10	Feedback Level	-63~+63	FBLevel	3	○

[16] PHASER1

No.	Parameter	Value	LCD	MIDI Parameter Number	Controller
1	LFO Frequency	0.0Hz~39.70Hz	Speed	1	○
2	LFO Depth	0-127	Depth	2	○
3	Diffusion	mono/stereo	Diffuse	6	○
4	EQ Low Frequency	32Hz~2.0kHz	L.Freq	7	○
5	EQ Low Gain	-12dB~+12dB	L.Gain	8	○
6	EQ High Frequency	500Hz~16.0kHz	H.Freq	9	○
7	EQ High Gain	-12dB~+12dB	H.Gain	10	○
8	Stage	4, 5, 6	Stage	5	○
9	Phase Shift Offset	0-127	PhShift	3	○
10	Feedback Level	-63~+63	FBLevel	4	◎

[17] TEMPO PHASER

No.	Parameter	Value	LCD	MIDI Parameter Number	Controller
1	LFO Frequency	5-21	Speed	1	○
2	LFO Depth	0-127	Depth	2	◎
3	LFO Phase Reset	off/free run, Key/OnReset, SEQ Start Reset	PhaseReset	6	○
4	EQ Low Frequency	32Hz~2.0kHz	L.Freq	7	○
5	EQ Low Gain	-12dB~+12dB	L.Gain	8	○
6	EQ High Frequency	500Hz~16.0kHz	H.Freq	9	○
7	EQ High Gain	-12dB~+12dB	H.Gain	10	○
8	Stage	4, 5, 6	Stage	5	○
9	Phase Shift Offset	0-127	PhShift	3	○
10	Feedback Level	-63~+63	FBLevel	4	○

[18] DELAY L,R(stereo)

No.	Parameter	Value	LCD	MIDI Parameter Number	Controller
1	Delay Time L	0.1ms~740.0ms	TimeL	1	○
2	Delay Time R	0.1ms~740.0ms	TimeR	2	○
3	Feedback Time 1	0.1ms~740.0ms	FBTime1	3	○
4	Feedback Time 2	0.1ms~740.0ms	FBTime2	4	○
5	Feedback Level	-63~+63	FBLevel	5	◎
6	Feedback High Damp	0.1~1.0	FBHiDmp	6	○
7	EQ Low Frequency	32Hz~2.0kHz	L.Freq	7	○
8	EQ Low Gain	-12dB~+12dB	L.Gain	8	○
9	EQ High Frequency	500Hz~16.0kHz	H.Freq	9	○
10	EQ High Gain	-12dB~+12dB	H.Gain	10	○

[19] CONTROL DELAY1(mono)

No.	Parameter	Value	LCD	MIDI Parameter Number	Controller
1	Delay Time	0.1ms~1480.0ms	Time	1	◎
2	Delay Transition Rate	1~48	Trnsitn	2	○
3	Feedback Level	-63~+63	FBLevel	3	○
4	Feedback High Damp	0.1~1.0	FBHiDmp	4	○
5	EQ Low Frequency	32Hz~2.0kHz	L.Freq	5	○
6	EQ Low Gain	-12dB~+12dB	L.Gain	6	○
7	EQ High Frequency	500Hz~16.0kHz	H.Freq	7	○
8	EQ High Gain	-12dB~+12dB	H.Gain	8	○

[20] CONTROL DELAY2(stereo)

No.	Parameter	Value	LCD	MIDI Parameter Number	Controller
1	Delay Time	0.1ms~740.0ms	Time	1	◎
2	Delay Transition Rate	1~48	Trnsitn	2	○
3	Feedback Level	-63~+63	FBLevel	3	○
4	Feedback High Damp	0.1~1.0	FBHiDmp	4	○
5	EQ Low Frequency	32Hz~2.0kHz	L.Freq	5	○
6	EQ Low Gain	-12dB~+12dB	L.Gain	6	○
7	EQ High Frequency	500Hz~16.0kHz	H.Freq	7	○
8	EQ High Gain	-12dB~+12dB	H.Gain	8	○

[21] TEMPO DELAY1(mono)

No.	Parameter	Value	LCD	MIDI Parameter Number	Controller
1	Delay Time	2~14	Time	1	○
2	Lag	-63ms~+63ms	Lag	5	○
3	L/R Diffusion	-63ms~+63ms	Diffuse	4	○
4	Feedback Level	-63~+63	FBLevel	2	◎
5	Feedback High Damp	0.1~1.0	FBHiDmp	3	○
6	EQ Low Frequency	32Hz~2.0kHz	L.Freq	6	○
7	EQ Low Gain	-12dB~+12dB	L.Gain	7	○
8	EQ High Frequency	500Hz~16.0kHz	H.Freq	8	○
9	EQ High Gain	-12dB~+12dB	H.Gain	9	○

[22] TEMPO DELAY2(stereo)

No.	Parameter	Value	LCD	MIDI Parameter Number	Controller
1	Delay Time	2~14	Time	1	○
2	Lag	-63ms~+63ms	Lag	5	○
3	L/R Diffusion	-63ms~+63ms	Diffuse	4	○
4	Feedback Level	-63~+63	FBLevel	2	◎
5	Feedback High Damp	0.1~1.0	FBHiDmp	3	○
6	EQ Low Frequency	32Hz~2.0kHz	L.Freq	6	○
7	EQ Low Gain	-12dB~+12dB	L.Gain	7	○
8	EQ High Frequency	500Hz~16.0kHz	H.Freq	8	○
9	EQ High Gain	-12dB~+12dB	H.Gain	9	○

[23] TEMPO CROSS DELAY

No.	Parameter	Value	LCD	MIDI Parameter Number	Controller
1	Delay Time L>R	2~14	TimeL>R	1	○
2	Delay Time R>L	2~14	TimeR>L	2	○
3	Input Select	L, R, L&R	Input	5	○
4	Lag	-63ms~+63ms	Lag	6	○
5	Feedback Level	-63~+63	FBLevel	3	◎
6	Feedback High Damp	0.1~1.0	FBHiDmp	4	○
7	EQ Low Frequency	32Hz~2.0kHz	L.Freq	7	○
8	EQ Low Gain	-12dB~+12dB	L.Gain	8	○
9	EQ High Frequency	500Hz~16.0kHz	H.Freq	9	○
10	EQ High Gain	-12dB~+12dB	H.Gain	10	○

3. Insertion Effect1

[0] THRU (パラメーターはなし)

[1]~[4]CHORUS1~4

[5]~[8]CELESTE1~4

No.	Parameter	Value	LCD	MIDI Parameter Number	Controller
1	LFO Frequency	0.0Hz~39.70Hz	Speed	1	○
2	LFO Depth	0~127	Depth	2	○
3	Input Mode	mono/stereo	Input	9	○
4	EQ Low Frequency	32Hz~2.0kHz	L.Freq	5	○
5	EQ Low Gain	-12dB~+12dB	L.Gain	6	○
6	EQ High Frequency	500Hz~16.0kHz	H.Freq	7	○
7	EQ High Gain	-12dB~+12dB	H.Gain	8	○
8	Delay Offset	0.0ms~50.0ms	DlyOfst	4	○
9	Feedback Level	-63~+63	FBLevel	3	○
10	Dry / Wet Balance	D63>W -D<W63	Dry/Wet	10	○

[9]-[11] FLANGER1-3

No.	Parameter	Value	LCD	MIDI Parameter Number	Controller
1	LFO Frequency	0.0Hz~39.70Hz	Speed	1	○
2	LFO Depth	0~127	Depth	2	○
3	LFO Phase Difference	-180deg~+180deg	Phase	9	○
4	EQ Low Frequency	32Hz~2.0kHz	L.Freq	5	○
5	EQ Low Gain	-12dB~+12dB	L.Gain	6	○
6	EQ High Frequency	500Hz~16.0kHz	H.Freq	7	○
7	EQ High Gain	-12dB~+12dB	H.Gain	8	○
8	Delay Offset	0.0ms~50.0ms	DlyOfst	4	○
9	Feedback Level	-63~+63	FBLevel	3	○
10	Dry / Wet Balance	D63>W ~ D=W ~ D<W63	Dry/Wet	10	○

[12] PHASER1

No.	Parameter	Value	LCD	MIDI Parameter Number	Controller
1	LFO Frequency	0.0Hz~39.70Hz	Speed	1	○
2	LFO Depth	0~127	Depth	2	○
3	EQ Low Frequency	32Hz~2.0kHz	L.Freq	6	○
4	EQ Low Gain	-12dB~+12dB	L.Gain	7	○
5	EQ High Frequency	500Hz~16.0kHz	H.Freq	8	○
6	EQ High Gain	-12dB~+12dB	H.Gain	9	○
7	Stage	4, 5, 6	Stage	5	○
8	Phase Shift Offset	0~127	PhShift	3	○
9	Feedback Level	-63~+63	FBLevel	4	○
10	Dry / Wet Balance	D63>W ~ D=W ~ D<W63	Dry/Wet	10	○

[13] TREMOLO

No.	Parameter	Value	LCD	MIDI Parameter Number	Controller
1	LFO Frequency	0.0Hz~39.70Hz	Speed	1	○
2	AM Depth	0~127	AMDepth	2	○
3	PM Depth	0~127	PMDepth	3	○
4	LFO Phase Difference	-180deg~+180deg	Phase	4	○
5	EQ Low Frequency	32Hz~2.0kHz	L.Freq	5	○
6	EQ Low Gain	-12dB~+12dB	L.Gain	6	○
7	EQ High Frequency	500Hz~16.0kHz	H.Freq	7	○
8	EQ High Gain	-12dB~+12dB	H.Gain	8	○
9	Input Mode	mono/stereo	Input	9	○

[14] AUTO PAN

No.	Parameter	Value	LCD	MIDI Parameter Number	Controller
1	LFO Frequency	0.0Hz~39.70Hz	Speed	1	○
2	L/R Depth	0~127	L/RDpth	2	○
3	F/R Depth	0~127	F/RDpth	3	○
4	PAN Direction	L<R, L>R, L<<R, L>>R, L<R, R<<L, R>>L, LR (0~5)	Directn	4	○
5	EQ Low Frequency	32Hz~2.0kHz	L.Freq	5	○
6	EQ Low Gain	-12dB~+12dB	L.Gain	6	○
7	EQ High Frequency	500Hz~16.0kHz	H.Freq	7	○
8	EQ High Gain	-12dB~+12dB	H.Gain	8	○

[15] DISTORTION

[16] OVERDRIVE

No.	Parameter	Value	LCD	MIDI Parameter Number	Controller
1	Drive	0~127	Drive	1	○
2	Edge	0~127	Edge	8	○
3	Output Level	0~127	OutLvl	9	○
4	EQ Low Frequency	32Hz~2.0kHz	L.Freq	2	○
5	EQ Low Gain	-12dB~+12dB	L.Gain	3	○
6	LPF Cutoff Frequency	1.0kHz~20.0kHz	LPF	7	○
7	EQ Mid Frequency	100Hz~10.0kHz	M.Freq	4	○
8	EQ Mid Gain	-12dB~+12dB	M.Gain	5	○
9	EQ Mid Width	0.1~12.0	M.Width	6	○
10	Dry / Wet Balance	D63>W ~ D=W ~ D<W63	Dry/Wet1	10	○

[17] AMP SIMULATOR

No.	Parameter	Value	LCD	MIDI Parameter Number	Controller
1	AMP Type	off, stack, combo, tube	AmpType	2	○
2	Drive	0~127	Drive	1	○
3	Edge	0~127	Edge	4	○
4	Output Level	0~127	OutLvl	5	○
5	LPF Cutoff Frequency	1.0kHz~20.0kHz	LPF	3	○
6	Dry / Wet Balance	D63>W ~ D=W ~ D<W63	Dry/Wet	6	○

[18] COMPRESSOR

No.	Parameter	Value	LCD	MIDI Parameter Number	Controller
1	Attack	1ms~40ms	Attack	1	○
2	Release	10ms~680ms	Release	2	○
3	Threshold	-48dB~-6dB	Thrsld	3	○
4	Ratio	1~20.0	Ratio	4	○
5	Output Level	0~127	OutLvl	5	○

[19] NOISE GATE

No.	Parameter	Value	LCD	MIDI Parameter Number	Controller
1	Attack	1ms~40ms	Attack	1	○
2	Release	10ms~680ms	Release	2	○
3	Threshold	-72dB~-30dB	Thrsld	3	○
4	Output Level	0~127	Out Lvl	4	○

[20] AUTO WAH

No.	Parameter	Value	LCD	MIDI Parameter Number	Controller
1	LFO Frequency	0.0Hz~39.70Hz	Speed	1	○
2	LFO Depth	0~127	Depth	2	○
3	Cutoff Frequency Offset	0~127	Cutoff	3	○
4	Resonance	1~12.0	Reso	4	○
5	EQ Low Frequency	32Hz~2.0kHz	L.Freq	5	○
6	EQ Low Gain	-12dB~+12dB	L.Gain	6	○
7	EQ High Frequency	500Hz~16.0kHz	H.Freq	7	○
8	EQ High Gain	-12dB~+12dB	H.Gain	8	○
9	Dry / Wet Balance	D63>W ~ D=W ~ D<W63	Dry/Wet	9	○

[21] TOUCH WAH

No.	Parameter	Value	LCD	MIDI Parameter Number	Controller
1	Sensitive	0~127	Sens	1	○
2	Cutoff Frequency Offset	0~127	Cutoff	2	○
3	Resonance	1~12.0	Reso	3	○
4	EQ Low Frequency	32Hz~2.0kHz	L.Freq	4	○
5	EQ Low Gain	-12dB~+12dB	L.Gain	5	○
6	EQ High Frequency	500Hz~16.0kHz	H.Freq	6	○
7	EQ High Gain	-12dB~+12dB	H.Gain	7	○
8	Dry / Wet Balance	D63>W ~ D=W ~ D<W63	Dry/Wet	8	○

[22] 2BAND EQ

No.	Parameter	Value	LCD	MIDI Parameter Number	Controller
1	EQ Low Frequency	32Hz~2.0kHz	L.Freq	1	○
2	EQ Low Gain	-12dB~+12dB	L.Gain	2	○
3	EQ High Frequency	500Hz~16.0kHz	H.Freq	3	○
4	EQ High Gain	-12dB~+12dB	H.Gain	4	○

[23] 3BAND EQ

No.	Parameter	Value	LCD	MIDI Parameter Number	Controller
1	EQ Low Frequency	50Hz~2.0kHz	L.Freq	1	○
2	EQ Low Gain	-12dB~+12dB	L.Gain	2	○
3	EQ High Frequency	500Hz~16.0kHz	H.Freq	6	○
4	EQ High Gain	-12dB~+12dB	H.Gain	7	○
5	EQ Mid Frequency	100Hz~10.0kHz	M.Freq	3	○
6	EQ Mid Gain	-12dB~+12dB	M.Gain	4	○
7	EQ Mid Width	0.1~12.0	M.Width	5	○
8	Input Mode	mono/stereo	Input	8	○

[24] HARMONIC ENHANCER

No.	Parameter	Value	LCD	MIDI Parameter Number	Controller
1	HPF Cutoff Frequency	500Hz~+16.0kHz	HPF	1	○
2	Drive	0~127	Drive	2	○
3	Mix Level	0~127	Mix Lvl	3	○

4.Insertion Effect2

[0] THRU (パラメータはなし)

[1] HALL1 ~ [8] PLATE

No.	Parameter	Value	LCD	MIDI Parameter Number	Controller
1	Reverb Time	0.3s~30.0s	RevTime	1	
2	Initial Delay	0.1ms~99.3ms	InitDly	3	
3	Reverb Delay	0.1ms~99.3ms	RevDly	11	
4	Dry / Wet Balance	D63>W ~ D=W ~ D<W63	Dry/Wet	10	○
5	HPF Cutoff Frequency	20Hz~8.0kHz	HPF	4	○
6	LPF Cutoff Frequency	1.0kHz~20.0kHz	LPF	5	○
7	Diffusion	0~10	Diffuse	2	
8	Density	0~4	Density	12	
9	ER / Rev Balance	E63>R ~ E=R ~ E<R63	ER/Rev	13	○
10	Feedback Level	-63~+63	FBLevel	15	○
11	Feedback High Damp	0.1~1.0	FBHiDmp	14	

[9] DELAY L,C,R

No.	Parameter	Value	LCD	MIDI Parameter Number	Controller
1	Delay Time L	0.1ms~1486.0ms	TimeL	1	
2	Delay Time R	0.1ms~1486.0ms	TimeR	2	
3	Delay Time C	0.1ms~1486.0ms	TimeC	3	
4	Dry / Wet Balance	D63>W ~ D=W ~ D<W63	Dry/Wet	10	○
5	Delay Level C	0~127	LevelC	6	○
6	Feedback Time	0.1ms~1486.0ms	FBTime	4	
7	Feedback Level	-63~+63	FBLevel	5	○
8	Feedback High Damp	0.1~1.0	FBHiDmp	7	○
9	EQ Low Frequency	32Hz~2.0kHz	L.Freq	13	○
10	EQ Low Gain	-12dB~+12dB	L.Gain	14	○
11	EQ High Frequency	500Hz~16.0kHz	H.Freq	15	○
12	EQ High Gain	-12dB~+12dB	H.Gain	16	○

[10] DELAY L,R

No.	Parameter	Value	LCD	MIDI Parameter Number	Controller
1	Delay Time L	0.1ms~1486.0ms	TimeL	1	
2	Delay Time R	0.1ms~1486.0ms	TimeR	2	
3	Dry / Wet Balance	D63>W ~ D=W ~ D<W63	Dry/Wet	10	○
4	Feedback Time 1	0.1ms~1486.0ms	FBTime1	3	
5	Feedback Time 2	0.1ms~1486.0ms	FBTime2	4	
6	Feedback Level	-63~+63	FBLevel	5	○
7	Feedback High Damp	0.1~1.0	FBHiDmp	6	○
8	EQ Low Frequency	32Hz~2.0kHz	L.Freq	13	○
9	EQ Low Gain	-12dB~+12dB	L.Gain	14	○
10	EQ High Frequency	500Hz~16.0kHz	H.Freq	15	○
11	EQ High Gain	-12dB~+12dB	H.Gain	16	○

[11] ECHO

No.	Parameter	Value	LCD	MIDI Parameter Number	Controller
1	Delay Time L1	0.1ms~743.0ms	TimeL1	1	
2	Delay Time R1	0.1ms~743.0ms	TimeR1	3	
3	Dry / Wet Balance	D63>W ~ D=W ~ D<W63	Dry/Wet	10	○
4	Feedback Level L	-63~+63	FBLvL	2	○
5	Feedback Level R	-63~+63	FBLvR	4	○
6	Feedback High Damp	0.1~1.0	FBHiDmp	5	○
7	Delay Time L2	0.1ms~743.0ms	TimeL2	6	
8	Delay Time R2	0.1ms~743.0ms	TimeR2	7	
9	Delay Level	0~127	Level2	8	○
10	EQ Low Frequency	32Hz~2.0kHz	L.Freq	13	○
11	EQ Low Gain	-12dB~+12dB	L.Gain	14	○
12	EQ High Frequency	500Hz~16.0kHz	H.Freq	15	○
13	EQ High Gain	-12dB~+12dB	H.Gain	16	○

[12] CROSS DELAY

No.	Parameter	Value	LCD	MIDI Parameter Number	Controller
1	Delay Time L>R	0.1ms~743.0ms	TimeL>R	1	
2	Delay Time R>L	0.1ms~743.0ms	TimeR>L	2	
3	Input Select	L, R, L&R	Input	4	
4	Dry / Wet Balance	D63>W ~ D=W ~ D<W63	Dry/Wet	10	○
5	Feedback Level	-63~+63	FBLevel	3	○
6	Feedback High Damp	0.1~1.0	FBHiDmp	5	○
7	EQ Low Frequency	32Hz~2.0kHz	L.Freq	13	○
8	EQ Low Gain	-12dB~+12dB	L.Gain	14	○
9	EQ High Frequency	500Hz~16.0kHz	H.Freq	15	○
10	EQ High Gain	-12dB~+12dB	H.Gain	16	○

[13] CONTROL DELAY1(mono)

No.	Parameter	Value	LCD	MIDI Parameter Number	Controller
1	Delay Time	0.1ms~1486.0ms	Time	1	○
2	Delay Transition Rate	1~48	Trnsitr	2	○
3	Dry / Wet Balance	D63>W ~ D=W ~ D<W63	Dry/Wet	10	○
4	Control Type	normal, scratch	CtrlType	11	○
5	Feedback Level	-63~+63	FBLevel	3	○
6	Feedback High Damp	0.1~1.0	FBHiDmp	4	○
7	EQ Low Frequency	32Hz~2.0kHz	L.Freq	6	○
8	EQ Low Gain	-12dB~+12dB	L.Gain	7	○
9	EQ High Frequency	500Hz~16.0kHz	H.Freq	8	○
10	EQ High Gain	-12dB~+12dB	H.Gain	9	○

[14] CONTROL DELAY2(stereo)

No.	Parameter	Value	LCD	MIDI Parameter Number	Controller
1	Delay Time	0.1ms~743.0ms	Time	1	○
2	Delay Transition Rate	1~48	Trnsitr	2	○
3	Dry / Wet Balance	D63>W ~ D=W ~ D<W63	Dry/Wet	10	○
4	Control Type	normal, scratch	CtrlType	11	○
5	Feedback Level	-63~+63	FBLevel	3	○
6	Feedback High Damp	0.1~1.0	FBHiDmp	4	○
7	EQ Low Frequency	32Hz~2.0kHz	L.Freq	6	○
8	EQ Low Gain	-12dB~+12dB	L.Gain	7	○
9	EQ High Frequency	500Hz~16.0kHz	H.Freq	8	○
10	EQ High Gain	-12dB~+12dB	H.Gain	9	○

[15] TEMPO DELAY1(mono)

No.	Parameter	Value	LCD	MIDI Parameter Number	Controller
1	Delay Time	2~14	Time	1	
2	Dry / Wet Balance	D63>W ~ D=W ~ D<W63	Dry/Wet	10	○
3	Lag	-63ms~+63ms	Lag	6	
4	L/R Diffusion	-63ms~+63ms	Diffuse	5	
5	Feedback Level	-63~+63	FBLevel	3	○
6	Feedback High Damp	0.1~1.0	FBHiDmp	4	○
7	EQ Low Frequency	32Hz~2.0kHz	L.Freq	13	○
8	EQ Low Gain	-12dB~+12dB	L.Gain	14	○
9	EQ High Frequency	500Hz~16.0kHz	H.Freq	15	○
10	EQ High Gain	-12dB~+12dB	H.Gain	16	○

[16] TEMPO DELAY2(stereo)

No.	Parameter	Value	LCD	MIDI Parameter Number	Controller
1	Delay Time	2~14	Time	1	
2	Dry / Wet Balance	D63>W ~ D=W ~ D<W63	Dry/Wet	10	○
3	Lag	-63ms~+63ms	Lag	6	
4	L/R Diffusion	-63ms~+63ms	Diffuse	5	
5	Feedback Level	-63~+63	FBLevel	3	○
6	Feedback High Damp	0.1~1.0	FBHiDmp	4	○
7	EQ Low Frequency	32Hz~2.0kHz	L.Freq	13	○
8	EQ Low Gain	-12dB~+12dB	L.Gain	14	○
9	EQ High Frequency	500Hz~16.0kHz	H.Freq	15	○
10	EQ High Gain	-12dB~+12dB	H.Gain	16	○

[17] TEMPO CROSS DELAY

No.	Parameter	Value	LCD	MIDI Parameter Number	Controller
1	Delay Time L>R	2~14	TimeL>R	1	
2	Delay Time R>L	2~14	TimeR>L	2	
3	Input Select	L, R, L&R	Input	6	
4	Dry / Wet Balance	D63>W ~ D=W ~ D<W63	Dry/Wet	10	○
5	Lag	-63ms~ +63ms	Lag	8	
6	Feedback Level	-63~+63	FBLevel	4	○
7	Feedback High Damp	0.1~1.0	FBHiDmp	5	○
8	EQ Low Frequency	32Hz~2.0kHz	L.Freq	13	○
9	EQ Low Gain	-12dB~+12dB	L.Gain	14	○
10	EQ High Frequency	500Hz~16.0kHz	H.Freq	15	○
11	EQ High Gain	-12dB~+12dB	H.Gain	16	○

[18]-[19] EARLY REF1-2

No.	Parameter	Value	LCD	MIDI Parameter Number	Controller
1	Type	S-hall, L-hall, random, reverse, plate, spring	Type	1	
2	Room Size	0.1~20.0	Size	2	
3	Dry / Wet Balance	D63>W ~ D=W ~ D<W63	Dry/Wet	10	○
4	Diffusion	0 ~ 10	Diffuse	3	
5	Initial Delay	0.1ms~200.0ms	InitDly	4	
6	Liveness	0 ~ 10	Livenss	11	
7	Density	0 ~ 3	Density	12	
8	HPF Cutoff Frequency	20Hz~8.0kHz	HPF	6	○
9	LPF Cutoff Frequency	1.0kHz~20.0kHz	LPF	7	○
10	Feedback Level	-63~+63	FBLevel	5	○
11	Feedback High Damp	0.1~1.0	FBHiDmp	13	

[20] GATE REVERB

[21] REVERSE GATE

No.	Parameter	Value	LCD	MIDI Parameter Number	Controller
1	Type	Type-A, Type-B	Type	1	
2	Room Size	0.1~20.0	Size	2	
3	Dry / Wet Balance	D63>W ~ D=W ~ D<W63	Dry/Wet	10	○
4	Diffusion	0 ~ 10	Diffuse	3	
5	Initial Delay	0.1ms~200.0ms	InitDly	4	
6	Liveness	0 ~ 10	Livenss	11	
7	Density	0 ~ 3	Density	12	
8	HPF Cutoff Frequency	20Hz~8.0kHz	HPF	6	○
9	LPF Cutoff Frequency	1.0kHz~20.0kHz	LPF	7	○
10	Feedback Level	-63~+63	FBLevel	5	○
11	Feedback High Damp	0.1~1.0	FBHiDmp	13	

[22]-[24] KARAOKE1-3

No.	Parameter	Value	LCD	MIDI Parameter Number	Controller
1	Delay Time	0.1ms~400.0ms	DlyTime	1	
2	Feedback Level	-63~+63	FBLevel	2	○
3	Dry / Wet Balance	D63>W ~ D=W ~ D<W63	Dry/Wet	10	○
4	HPF Cutoff Frequency	20Hz~8.0kHz	HPF	3	○
5	LPF Cutoff Frequency	1.0kHz~20.0kHz	LPF	4	○

[25]-[29] CHORUS1-5

[30]-[33] CELESTE1-4

No.	Parameter	Value	LCD	MIDI Parameter Number	Controller
1	LFO Frequency	0.0Hz~39.70Hz	Speed	1	○
2	LFO Depth	0~127	Depth	2	○
3	Input Mode	mono/stereo	Input	15	
4	EQ Low Frequency	32Hz~2.0kHz	L.Freq	6	○
5	EQ Low Gain	-12dB~+12dB	L.Gain	7	○
6	EQ High Frequency	500Hz~16.0kHz	H.Freq	8	○
7	EQ High Gain	-12dB~+12dB	H.Gain	9	○
8	EQ Mid Frequency	100Hz~10.0kHz	M.Freq	11	○
9	EQ Mid Gain	-12dB~+12dB	M.Gain	12	○
10	EQ Mid Width	0.1~12.0	M.Width	13	○
11	Delay Offset	0.0ms~50.0ms	DlyOfst	4	
12	Feedback Leve	-63~+63	FBLevel	3	○
13	Dry / Wet Balance	D63>W ~ D=W ~ D<W63	Dry/Wet	10	○

[34] SYMPHONIC

No.	Parameter	Value	LCD	MIDI Parameter Number	Controller
1	LFO Frequency	0.0Hz~39.70Hz	Speed	1	○
2	LFO Depth	0~127	Depth	2	○
3	Delay Offset	0.0ms~50.0ms	DlyOfst	4	
4	EQ Low Frequency	32Hz~2.0kHz	L.Freq	6	○
5	EQ Low Gain	-12dB~+12dB	L.Gain	7	○
6	EQ High Frequency	500Hz~16.0kHz	H.Freq	8	○
7	EQ High Gain	-12dB~+12dB	H.Gain	9	○
8	EQ Mid Frequency	100Hz~10.0kHz	M.Freq	11	○
9	EQ Mid Gain	-12dB~+12dB	M.Gain	12	○
10	EQ Mid Width	0.1~12.0	M.Width	13	○
11	Dry / Wet Balance	D63>W ~ D=W ~ D<W63	Dry/Wet	10	○

[35] ENSEMBLE DETUNE

No.	Parameter	Value	LCD	MIDI Parameter Number	Controller
1	Detune	-50cent~+50cent	Detune	1	
2	Initial Delay Lch	0.0ms~50.0ms	DelayL	2	
3	Initial Delay Rch	0.0ms~50.0ms	DelayR	3	
4	Dry / Wet Balance	D63>W ~ D=W ~ D<W63	Dry/Wet	10	○
5	EQ Low Frequency	32Hz~2.0kHz	L.Freq	11	○
6	EQ Low Gain	-12dB~+12dB	L.Gain	12	○
7	EQ High Frequency	500Hz~16.0kHz	H.Freq	13	○
8	EQ High Gain	-12dB~+12dB	H.Gain	14	○

[36]-[38] FLANGER1-3

No.	Parameter	Value	LCD	MIDI Parameter Number	Controller
1	LFO Frequency	0.0Hz~39.70Hz	Speed	1	○
2	LFO Depth	0~127	Depth	2	○
3	LFO Phase Difference	-180deg~+180deg	Phase	14	
4	EQ Low Frequency	32Hz~2.0kHz	L.Freq	6	○
5	EQ Low Gain	-12dB~+12dB	L.Gain	7	○
6	EQ High Frequency	500Hz~16.0kHz	H.Freq	8	○
7	EQ High Gain	-12dB~+12dB	H.Gain	9	○
8	EQ Mid Frequency	100Hz~10.0kHz	M.Freq	11	○
9	EQ Mid Gain	-12dB~+12dB	M.Gain	12	○
10	EQ Mid Width	0.1~12.0	M.Width	13	○
11	Delay Offset	0.0ms~50.0ms	DlyOfst	4	
12	Feedback Leve	-63~+63	FBLevel	3	○
13	Dry / Wet Balance	D63>W ~ D=W ~ D<W63	Dry/Wet	10	○

[39] V-FLANGER

No.	Parameter	Value	LCD	MIDI Parameter Number	Controller
1	LFO Frequency	0.0Hz~39.70Hz	Speed	1	○
2	LFO Depth	0~127	Depth	2	○
3	LFO Wave	Triangle, Sine, Random	Wave	3	
4	Modulation Phase	-180~+180	Phase	5	
5	EQ Low Frequency	32Hz~2.0kHz	L.Freq	6	○
6	EQ Low Gain	-12dB~+12dB	L.Gain	7	○
7	EQ High Frequency	500Hz~16.0kHz	H.Freq	8	○
8	EQ High Gain	-12dB~+12dB	H.Gain	9	○
9	EQ Mid Frequency	100Hz~10.0kHz	M.Freq	11	○
10	EQ Mid Gain	-12dB~+12dB	M.Gain	12	○
11	EQ Mid Width	0.1~12.0	M.Width	13	○
12	Analog Feel	0~10	Analog	16	○
13	Feedback Gain	-100~+100%	FBLevel	14	○
14	Feedback High Damp	0.1~1.0	FBHiDmp	15	○
15	Delay Offset	0.09~36.21ms	DlyOfst	4	
16	Dry / Wet Balance	D63>W ~ D=W ~ D<W63	Dry/Wet	10	○

[40] TEMPO FLANGER

No.	Parameter	Value	LCD	MIDI Parameter Number	Controller
1	LFO Frequency	5~21	Speed	1	○
2	LFO Depth	0~127	Depth	2	○
3	LFO Phase Difference	-180deg~+180deg	Phase	14	
4	LFO Phase Reset	off/free run, KeyOn/Reset, SEQ Start/Reset	Reset	5	
5	EQ Low Frequency	32Hz~2.0kHz	L.Freq	6	○
6	EQ Low Gain	-12dB~+12dB	L.Gain	7	○
7	EQ High Frequency	500Hz~16.0kHz	H.Freq	8	○
8	EQ High Gain	-12dB~+12dB	H.Gain	9	○
9	EQ Mid Frequency	100Hz~10.0kHz	M.Freq	11	○
10	EQ Mid Gain	-12dB~+12dB	M.Gain	12	○
11	EQ Mid Width	0.1~12.0	M.Width	13	○
12	Delay Offset	0.0ms~50.0ms	DlyOfst	4	
13	Feedback Level	-63~+63	FBLevel	3	○
14	Dry / Wet Balance	D63>W ~ D=W ~ D<W63	Dry/Wet	10	○

[41] PHASER1

No.	Parameter	Value	LCD	MIDI Parameter Number	Controller
1	LFO Frequency	0.0Hz~39.70Hz	Speed	1	○
2	LFO Depth	0~127	Depth	2	○
3	Diffusion	mono/stereo	Diffuse	12	
4	EQ Low Frequency	32Hz~2.0kHz	L.Freq	6	○
5	EQ Low Gain	-12dB~+12dB	L.Gain	7	○
6	EQ High Frequency	500Hz~16.0kHz	H.Freq	8	○
7	EQ High Gain	-12dB~+12dB	H.Gain	9	○
8	Stage	4, 5, 6, 7, 8, 9, 10, 11, 12	Stage	11	○
9	Phase Shift Offset	0~127	PhShift	3	
10	Feedback Level	-63~+63	FBLevel	4	○
11	Dry / Wet Balance	D63>W ~ D=W ~ D<W63	Dry/Wet	10	○

[54] ROTARY SPEAKER3

[55] ROTARY SPEAKER4

No.	Parameter	Value	LCD	MIDI Parameter Number	Controller
1	Speed Control	sLow, fast	Speed	16	○
2	SLOW-Fast Time of R	0~127	Trans:Rotor	5	○
3	SLOW-Fast Time of H	0~127	Trans:Horn	6	○
4	Rotor Speed SLOW	0.0Hz~2.65Hz	Rotor-Slw	1	○
5	Horn Speed SLOW	0.0Hz~2.65Hz	Horn-Slw	2	○
6	Rotor Speed Fast	2.69Hz~39.70Hz	Rotor-Fst	3	○
7	Horn Speed Fast	2.69Hz~39.70Hz	Horn-Fst	4	○
8	Mic L-R Angle	0deg~180deg	MicAngl	15	○
9	Drive Low	0~127	DriveLo	7	○
10	Drive High	0~127	DriveHi	8	○
11	Low/High Balance	L63>H ~ L=H ~ L<H63	Low/Hi	9	○
12	EQ Low Frequency	32Hz~2.0kHz	L.Freq	11	○
13	EQ Low Gain	-12dB~+12dB	L.Gain	12	○
14	EQ High Frequency	500Hz~16.0kHz	H.Freq	13	○
15	EQ High Gain	-12dB~+12dB	H.Gain	14	○

[56] DISTORTION

No.	Parameter	Value	LCD	MIDI Parameter Number	Controller
1	Drive	0~127	Drive	1	○
2	Edge	0~127	Edge	11	○
3	Output Level	0~127	OutLvl	5	○
4	EQ Low Frequency	32Hz~2.0kHz	L.Freq	2	○
5	EQ Low Gain	-12dB~+12dB	L.Gain	3	○
6	LPF Cutoff Frequency	1.0kHz~20.0kHz	LPF	4	○
7	EQ Mid Frequency	100Hz~10.0kHz	M.Freq	7	○
8	EQ Mid Gain	-12dB~+12dB	M.Gain	8	○
9	EQ Mid Width	0.1~12.0	M.Width	9	○
10	Dry / Wet Balance	D63>W ~ D=W ~ D<W63	Dry/Wet	10	○

[57] COMP DISTORTION

No.	Parameter	Value	LCD	MIDI Parameter Number	Controller
1	Attack	1ms~40ms	Attack	12	○
2	Release	10ms~680ms	Release	13	○
3	Threshold	-48dB~-6dB	Thrsld	14	○
4	Ratio	1~20.0	Ratio	15	○
5	EQ Low Frequency	32Hz~2.0kHz	L.Freq	2	○
6	EQ Low Gain	-12dB~+12dB	L.Gain	3	○
7	Drive	0~127	Drive	1	○
8	Output Level	0~127	OutLvl	5	○
9	EQ Mid Frequency	100Hz~10.0kHz	M.Freq	7	○
10	EQ Mid Gain	-12dB~+12dB	M.Gain	8	○
11	EQ Mid Width	0.1~12.0	M.Width	9	○
12	Edge	0~127	Edge	11	○
13	LPF Cutoff Frequency	1.0kHz~20.0kHz	LPF	4	○
14	Dry / Wet Balance	D63>W ~ D=W ~ D<W63	Dry/Wet	10	○

[58] V-DISTORTION

No.	Parameter	Value	LCD	MIDI Parameter Number	Controller
1	Over Drive	0 ~ 100%	OverDr	1	○
2	Device	Transier, Vintage Tube, Distortion1, Distortion2, Fuzz	Device	2	○
3	Speaker Type	Flat, Stack, Combo, Twin, Radio, Megaphone	Speaker	3	○
4	Presence	-10 ~ 10	Presenc	4	○
5	Delay Time L	0.1ms~1486.0ms	DelayL	6	○
6	Delay Time R	0.1ms~1486.0ms	DelayR	7	○
7	Feedback Time	0.1ms~1486.0ms	FBTime	8	○
8	Feedback Level	-63~+63	FBLevel	9	○
9	Feedback High Damp	0.1~1.0	FBHiDmp	12	○
10	Output Level	0 ~ 100%	DistLvl	5	○
11	Delay Mix	0 ~ 127	DlyMix	11	○
12	Dry/Wet Balance	D63>W ~ D=W ~ D<W63	Dry/Wet	10	○

[59] OVERDRIVE

No.	Parameter	Value	LCD	MIDI Parameter Number	Controller
1	Drive	0~127	Drive	1	○
2	Edge	0~127	Edge	11	○
3	Output Level	0~127	OutLvl	5	○
4	EQ Low Frequency	32Hz~2.0kHz	L.Freq	2	○
5	EQ Low Gain	-12dB~+12dB	L.Gain	3	○
6	LPF Cutoff Frequency	1.0kHz~20.0kHz	LPF	4	○
7	EQ Mid Frequency	100Hz~10.0kHz	M.Freq	7	○
8	EQ Mid Gain	-12dB~+12dB	M.Gain	8	○
9	EQ Mid Width	0.1~12.0	M.Width	9	○
10	Dry / Wet Balance	D63>W ~ D=W ~ D<W63	Dry/Wet	10	○

[60] AMP SIMULATOR

No.	Parameter	Value	LCD	MIDI Parameter Number	Controller
1	AMP Type	off, stack, combo, tube	AmpType	2	○
2	Drive	0~127	Drive	1	○
3	Edge	0~127	Edge	11	○
4	Output Level	0~127	OutLvl	4	○
5	LPF Cutoff Frequency	1.0kHz~20.0kHz	LPF	3	○
6	Dry / Wet Balance	D63>W ~ D=W ~ D<W63	Dry/Wet	10	○

[61] DIST+DELAY

[62] OVERDRIVE+DELAY

No.	Parameter	Value	LCD	MIDI Parameter Number	Controller
1	Dist. Drive	0~127	Drive	6	○
2	Dist. EQ Low Gain	-12dB~+12dB	EQ-Low	8	○
3	Dist. EQ Mid Gain	-12dB~+2dB	EQ-Mid	9	○
4	Dist Output Level	0~127	DrvOut	7	○
5	Delay Time L	0.1ms~1486.0ms	DelayL	1	○
6	Delay Time R	0.1ms~1486.0ms	DelayR	2	○
7	Delay Feedback Time	0.1ms~1486.0ms	FBTime	3	○
8	Delay Feedback Leve	-63~+63	FBLevel	4	○
9	Delay mix	0~127	DlyMix	5	○
10	Dry / Wet Balance	D63>W ~ D=W ~ D<W63	Dry/Wet	10	○

[63] COMPRESSOR1

No.	Parameter	Value	LCD	MIDI Parameter Number	Controller
1	Attack	1ms~40ms	Attack	1	○
2	Release	10ms~680ms	Release	2	○
3	Threshold	-48dB~-6dB	Thrsld	3	○
4	Ratio	1~20.0	Ratio	4	○
5	Output Level	0~127	OutLvl	5	○

[64] NOISE GATE

No.	Parameter	Value	LCD	MIDI Parameter Number	Controller
1	Attack	1ms~40ms	Attack	1	○
2	Release	10ms~680ms	Release	2	○
3	Threshold	-72dB~-30dB	Thrsld	3	○
4	Output Level	0~127	OutLvl	4	○

[65] COMP+DIST+DELAY

[66] COMP+ODRV+DELAY

No.	Parameter	Value	LCD	MIDI Parameter Number	Controller
1	Comp. Attack	1ms~40ms	Attack	11	○
2	Comp. Release	10ms~680ms	Release	12	○
3	Comp. Threshold	-48dB~-6dB	Thrsld	13	○
4	Comp. Ratio	1~20.0	Ratio	14	○
5	Dist. Drive	0~127	Drive	4	○
6	Dist. EQ Low Gain	-12dB~+12dB	EQ-Low	6	○
7	Dist. EQ Mid Gain	-12dB~+12dB	EQ-Mid	7	○
8	Dist Output Level	0~127	DrvOut	5	○
9	Delay Time	0.1ms~1486.0ms	DlyTime	1	○
10	Delay Feedback Level	-63~+63	FBLevel	2	○
11	Delay Mix	0~127	DlyMix	3	○
12	Dry / Wet Balance	D63>W ~ D=W ~ D<W63	Dry/Wet	10	○

[67] PITCH CHANGE1

[68] PITCH CHANGE2

No.	Parameter	Value	LCD	MIDI Parameter Number	Controller
1	Pitch	-24~+24	Pitch	1	○
2	Initial Delay	0.1ms~248.9ms	InitDly	2	○
3	Feedback Level	-63~+63	FBLevel	5	○
4	Dry / Wet Balance	D63>W ~ D=W ~ D<W63	Dry/Wet	10	○
5	Fine1	-50~+50	Fine1	3	○
6	Fine2	-50~+50	Fine2	4	○
7	Pan1	L63~C~R63	Pan1	11	○
8	Output Level1	0~127	OutLvl1	12	○
9	Pan2	L63~C~R63	Pan2	13	○
10	Output Level2	0~127	OutLvl2	14	○

[68] PITCH CHANGE2 のとき、5. fine1、6. fine2 は単位が [cent]

[69] AUTO WAH

No.	Parameter	Value	LCD	MIDI Parameter Number	Controller
1	LFO Frequency	0.0Hz~39.70Hz	Speed	1	○
2	LFO Depth	0~127	Depth	2	○
3	Cutoff Frequency Offset	0~127	Cutoff	3	○
4	Resonance	1~12.0	Reso	4	○
5	EQ Low Frequency	32Hz~2.0kHz	L.Freq	6	○
6	EQ Low Gain	-12dB~+12dB	L.Gain	7	○
7	EQ High Frequency	500Hz~16.0kHz	H.Freq	8	○
8	EQ High Gain	-12dB~+12dB	H.Gain	9	○
9	Dry / Wet Balance	D63>W ~ D=W ~ D<W63	Dry/Wet	10	○

[70] AUTO WAH + DIST**[71] AUTO WAH + OVERDRIVE**

No.	Parameter	Value	LCD	MIDI Parameter Number	Controller
1	LFO Frequency	0.0Hz~39.70Hz	Speed	1	○
2	LFO Depth	0~127	Depth	2	○
3	Cutoff Frequency Offset	0~127	Cutoff	3	○
4	Resonance	1~12.0	Reso	4	○
5	EQ Low Frequency	32Hz~2.0kHz	L.Freq	6	○
6	EQ Low Gain	-12dB~+12dB	L.Gain	7	○
7	EQ High Frequency	500Hz~16.0kHz	H.Freq	8	○
8	EQ High Gain	-12dB~+12dB	H.Gain	9	○
9	Dist Low Gain	-12dB~+12dB	Drive:EQ-Low	12	○
10	Dist Mid Gain	-12dB~+12dB	Drive:EQ-Mid	13	○
11	LPF Cutoff Frequency	1.0kHz~20.0kHz	LPF	14	○
12	Drive	0~127	Drive	11	○
13	Output Level	0~127	DrivOut	15	○
14	Dry / Wet Balance	D63>W ~ D=W ~ D<W63	Dry/Wet	10	○

[72] TOUCH WAH

No.	Parameter	Value	LCD	MIDI Parameter Number	Controller
1	Sensitive	0~127	Sens	1	○
2	Cutoff Frequency Offset	0~127	Cutoff	2	○
3	Resonance	1~12.0	Reso	3	○
4	EQ Low Frequency	32Hz~12.0kHz	L.Freq	6	○
5	EQ Low Gain	-12dB~+12dB	L.Gain	7	○
6	EQ High Frequency	500Hz~16.0kHz	H.Freq	8	○
7	EQ High Gain	-12dB~+12dB	H.Gain	9	○
8	Dry / Wet Balance	D63>W ~ D=W ~ D<W63	Dry/Wet	10	○

[73] TOUCH WAH + DIST**[74] TOUCH WAH + OVERDRIVE**

No.	Parameter	Value	LCD	MIDI Parameter Number	Controller
1	Sensitive	0~127	Sens	1	○
2	Cutoff Frequency Offset	0~127	Cutoff	2	○
3	Resonance	1~12.0	Reso	3	○
4	EQ Low Frequency	32Hz~2.0kHz	L.Freq	6	○
5	EQ Low Gain	-12dB~+12dB	L.Gain	7	○
6	EQ High Frequency	500Hz~16.0kHz	H.Freq	8	○
7	EQ High Gain	-12dB~+12dB	H.Gain	9	○
8	Dist Low Gain	-12dB~+12dB	Drive:EQ-Low	12	○
9	Dist Mid Gain	-12dB~+12dB	Drive:EQ-Mid	13	○
10	LPF Cutoff Frequency	1.0kHz~20.0kHz	LPF	14	○
11	Drive	0~127	Drive	11	○
12	Output Level	0~127	DrivOut	15	○
13	Dry / Wet Balance	D63>W ~ D=W ~ D<W63	Dry/Wet	10	○

[75] WAH + DIST + DELAY**[76] WAH + OVERDRIVE + DELAY**

No.	Parameter	Value	LCD	MIDI Parameter Number	Controller
1	Wah sensitive	0~127	WahSens	11	○
2	Wah Cutoff Frequency	0~127	Cutoff	12	○
3	Wah Resonance	1~12.0	Reso	13	○
4	Wah release	10ms~680ms	Release	14	○
5	Dist. Drive	0~127	Drive	4	○
6	Dist. EQ Low Gain	-12dB~+12dB	EQ-Low	6	○
7	Dist. EQ Mid Gain	-12dB~+12dB	EQ-Mid	7	○
8	Dist Output Level	0~127	DrivOut	5	○
9	Delay Time	0.1ms~1486.0ms	Delay	1	○
10	Delay Feedback Leve	-63~+63	FBLevel	2	○
11	Delay mix	0~127	DlyMix	3	○
12	Dry / Wet Balance	D63>W ~ D=W ~ D<W63	Dry/Wet	10	○

[77] LO-FI

No.	Parameter	Value	LCD	MIDI Parameter Number	Controller
1	Sampling Freq. Control	44.1kHz~344Hz	SmpIFrq	1	○
2	Word Length	1~127	WordLen	2	○
3	Output Gain	-6dB~+36dB	OutGain	3	○
4	Filter Type	thru, PowerBass, Radio, Telephone, Clean, Low	FltType	5	○
5	Pre-LPF Cutoff Frequency	63Hz~20.0kHz	Cutoff	4	○
6	Pre-LPF Resonance	1~12.0	Reso	6	○
7	Bit Assign	0~6	BitAsgn	7	○
8	Emphasis	off/on	Emphasi	8	○
9	Input Mode	mono/stereo	Input	15	○
10	Dry / Wet Balance	D63>W ~ D=W ~ D<W63	Dry/Wet	10	○

[78] LOW RESOLUTION

No.	Parameter	Value	LCD	MIDI Parameter Number	Controller
1	Mod Depth	0~127	ModDpth	1	○
2	Mod Delay Offset	1~127	ModDly	2	○
3	Mod Mix Balance	0~127	ModMix	5	○
4	Resolution	1,1/2~1/128	Resoltn	4	○
5	Mod Feedback	-63~+63	ModFB	3	○
6	Phase Inverse R	off, wet, wet+dry	PhasInlv	6	○
7	Dry/Wet Balance	D63>W ~ D=W ~ D<W63	Dry/Wet	7	○

[79] NOISY

No.	Parameter	Value	LCD	MIDI Parameter Number	Controller
1	Mod Depth	0~10	ModDpth	2	○
2	Mod Speed	0~127	ModSpd	3	○
3	Mod Feedback	-63~+63	ModFB	4	○
4	Mod Mix Balance	1~127	ModMix	7	○
5	Drive	0~127	Drive	1	○
6	AM Speed	0.00Hz~39.7Hz	AMSpeed	5	○
7	AM Depth	0~127	AMDepth	6	○
8	LPF Frequency	1.0kHz~20.0kHz	Cutoff	8	○
9	LPF Resonance	1.0~12.0	Reso	9	○
10	EQ Frequency	100Hz~10.0kHz	EQFreq	10	○
11	EQ Gain	-12~+12dB	EQGain	11	○
12	EQ Width	1.0~12.0	EQWidth	12	○
13	Dry/Wet Balance	D63>W ~ D=W ~ D<W63	Dry/Wet	13	○

[80] ATTACK LOFI

No.	Parameter	Value	LCD	MIDI Parameter Number	Controller
1	Sensitive	0~127	Sens	1	○
2	Resolution	1,1/2~1/32	Resoltn	2	○
3	Peak Frequency	100Hz~10.0kHz	PeakFrq	3	○
4	LPF Frequency	1.0kHz~20.0kHz	LPF	4	○
5	Flanger Speed	0.00Hz~39.7Hz	FlgSpd	5	○
6	Flanger LFO Wave	tri, sine, saw up, saw down	FlgWave	6	○
7	Flanger Depth	0~127	FlgDpt	7	○
8	Fln Depth Ofst R	-63~+63	FlgDptR	8	○
9	Flanger Delay	0.1~650.0ms	FlgDly	9	○
10	Fln Delay Ofst R	0~884	FlgDlyR	10	○
11	Flanger Feedback	-63~+63	FlgFB	11	○
12	Flanger FB Ofst R	-63~+63	FlgFB R	12	○
13	Flanger FB Hidamp	0.1~1.0	FBHIDmp	13	○
14	FB Hidamp Ofst R	-0.9~+0.9	FBHIDmR	14	○
15	Fln Mix Balance	1~127	FlgMix	15	○
16	Dry/Wet Balance	D63>W ~ D=W ~ D<W63	Dry/Wet	16	○

[81] DIGITAL TURNTABLE

No.	Parameter	Value	LCD	MIDI Parameter Number	Controller
1	Click Density	0~5	Density	1	○
2	Click Level	0~127	Click	2	○
3	Noise Tone	0~6	NoisTon	3	○
4	Dry Send to Noise	0~127	DryNois	6	○
5	Noise Mod Speed	0.00Hz~39.7Hz	ModSpd	4	○
6	Noise Mod Depth	0~127	ModDpth	5	○
7	Noise LPF Freq	1.0kHz~20.0kHz	NoisLPF	7	○
8	Noise LPF Q	1.0~12.0	NoiseQ	8	○
9	Noise Level	0~127	NoisLvl	9	○
10	Dry LPF Frequency	1.0kHz~20.0kHz	DryLPF	10	○
11	Dry Level	0~127	DryLvl	11	○

[82] DIGITAL SCRATCH

No.	Parameter	Value	LCD	MIDI Parameter Number	Controller
1	Input Level	0~127	Input	1	○
2	Initial Delay	0.1~460.0ms	Delay	2	○
3	Scratch Speed	1~127	ScrSpd	3	○
4	Scratch Depth	0~127	ScrDpth	4	○
5	HPF Frequency	20Hz~8.0kHz	HPF	10	○
6	Auto Pan Speed	0.00Hz~39.7Hz	PanSpd	5	○
7	Auto Pan Depth	0~127	PanDpth	6	○
8	EQ Frequency	100Hz~10.0kHz	EQFreq	7	○
9	EQ Gain	-12~+12dB	EQGain	8	○
10	EQ Width	1.0~12.0	EQWidth	9	○
11	Dry/Wet Balance	D63>W ~ D=W ~ D<W63	Dry/Wet	11	○

[83] AUTO SYNTH

No.	Parameter	Value	LCD	MIDI Parameter Number	Controller
1	Mod Speed	0-127	ModSpd	1	○
2	Mod Wave Type	TypeA, TypeB, TypeC, TypeD	ModWave	2	
3	Mod Depth	0-127	ModDpth	3	○
4	Mod Depth Ofst R	-63+63	ModDpth-R Ofst	4	○
5	HPF Frequency	20Hz-8.0kHz	HPF	6	○
6	LPF Frequency	1.0kHz-20.0kHz	LPF	5	○
7	Dry Mix Level	0-127	DryMix	7	○
8	Delay Level	0-127	DlyLvl	12	○
9	Delay Time	0.1-370.0ms	Delay	8	
10	Delay Time Ofst R	0-884	Delay-R Ofst	9	
11	Feedback Level	-63+63	FBLevel	10	○
12	FB Level Ofst R	-63+63	FBLevel-R Ofst	11	○
13	AM Speed	0.00Hz-39.7Hz	AMSpeed	13	○
14	AM Wave	tri, sine, saw up, saw down	AM Wave	14	
15	AM Depth	0-127	AMDepth	15	○
16	AM Inverse R	normal, inverse	AM InvR	16	

[84] TECH MODULATION

No.	Parameter	Value	LCD	MIDI Parameter Number	Controller
1	Mod Speed	0-127	Speed	1	○
2	Mod Depth	0-127	Depth	2	○
3	Mod Gain	-12+12dB	Gain	4	○
4	Mod Mix Balance	D63>W ~ D=W ~ D<W63	ModMix	7	○
5	Pre Mod HPF Freq	20Hz-8.0kHz	HPF	3	○
6	Mod LPF Frequency	1.0kHz-20.0kHz	LPF:Cutoff	5	○
7	Mod LPF Resonance	1.0-12.0	LPF:Reso	6	○
8	Delay Time	0.1-740.0ms	Delay	8	
9	Delay Time Ofst R	0-884	Delay-R Ofst	9	
10	Feedback Level	-63+63	FBLevel	10	○
11	FB Level Ofst R	-63+63	FBLevel-R Ofst	11	○
12	Feedback Hi Damp	0.1-1.0	FBHiDmp	12	○
13	FB Hi Damp Ofst R	-0.9+0.9	FBHiDmp-R Ofst	13	○
14	Dry/Wet Balance	D63>W ~ D=W ~ D<W63	Dry/Wet	14	○

[85] JUMP

No.	Parameter	Value	LCD	MIDI Parameter Number	Controller
1	Depth	0-127	Depth	1	○
2	Speed	0-127	Speed	2	○
3	Direction	L<>R,L>>R	Directn	3	
4	Type	TypeA, TypeB, TypeC	Type	4	
5	Jump Wave Type	TypeA, TypeB, TypeC, TypeD	JumpWave	5	
6	Resolution	1,1/2-1/256	Resolution	6	
7	HPF Frequency	20Hz-8.0kHz	HPF	8	○
8	LPF Frequency	1.0kHz-20.0kHz	LPF	7	○
9	Dry/Wet Balance	D63>W ~ D=W ~ D<W63	Dry/Wet	9	○

[86] 2BAND EQ

No.	Parameter	Value	LCD	MIDI Parameter Number	Controller
1	EQ Low Frequency	32Hz-2.0kHz	L.Freq	1	○
2	EQ Low Gain	-12dB+12dB	L.Gain	2	○
3	EQ High Frequency	500Hz-16.0kHz	H.Freq	3	○
4	EQ High Gain	-12dB+12dB	H.Gain	4	○

[87] 3BAND EQ

No.	Parameter	Value	LCD	MIDI Parameter Number	Controller
1	EQ Low Frequency	50Hz-2.0kHz	L.Freq	6	○
2	EQ Low Gain	-12dB+12dB	L.Gain	1	○
3	EQ High Frequency	500Hz-16.0kHz	H.Freq	7	○
4	EQ High Gain	-12dB+12dB	H.Gain	5	○
5	EQ Mid Frequency	100Hz-10.0kHz	M.Freq	2	○
6	EQ Mid Gain	-12dB+12dB	M.Gain	3	○
7	EQ Mid Width	0.1-12.0	M.Width	4	○
8	Input Mode	mono/stereo	Input	15	

[88] HARMONIC ENHANCER

No.	Parameter	Value	LCD	MIDI Parameter Number	Controller
1	HPF Cutoff Frequency	500Hz-16.0kHz	HPF	1	○
2	Drive	0-127	Drive	2	○
3	Mix Level	0-127	MixLvl	3	○

[89] VOICE CANCELAR

No.	Parameter	Value	LCD	MIDI Parameter Number	Controller
1	Low Adjust	0-26	LowAdj	11	○
2	High Adjust	0-26	HighAdj	12	○

[90] AMBIENCE

No.	Parameter	Value	LCD	MIDI Parameter Number	Controller
1	Delay Time	0.0ms-50.0ms	DlyTime	1	
2	Wet Output Phase	normal/inverse	WetPhase	2	○
3	Dry / Wet Balance	D63>W ~ D=W ~ D<W63	Dry/Wet	10	○
4	EQ Low Frequency	32Hz-2.0kHz	L.Freq	6	○
5	EQ Low Gain	-12dB+12dB	L.Gain	7	○
6	EQ High Frequency	500Hz-16.0kHz	H.Freq	8	○
7	EQ High Gain	-12dB+12dB	H.Gain	9	○

[91] TALKING MODULATOR

No.	Parameter	Value	LCD	MIDI Parameter Number	Controller
1	Vowel	a/i/u/e/o	Vowel	1	○
2	Move Speed	1-62	Speed	2	○
3	Drive	0-127	Drive	3	○
4	Output Level	0-127	OutLvl	4	○

[92] BEAT CHANGE

No.	Parameter	Value	LCD	MIDI Parameter Number	Controller
1	Beat Change	-63+63	BeatChg	1	○
2	Beat Range	0-12	BeatRng	2	○
3	Pitch Change	-63+63	PchChg	3	○
4	Pitch Range	0-12	PchRng	4	○
5	EQ Frequency	32Hz-2.0kHz	EQFreq	6	○
6	EQ Gain	-12dB+12dB	EQGain	7	○
7	EQ Width	1.0-12.0	EQWidth	8	○
8	Accuracy Type	sound4-normal-rythm4	AccType	5	
9	Dry/Wet Balance	D63>W ~ D=W ~ D<W63	Dry/Wet	10	○

MIDIについて

MIDI(ミディ)は、Musical Instrument Digital Interfaceの頭文字をとったもので、楽器同士を接続して演奏情報や音色情報などをやりとりするために作られた世界統一の規格です。世界統一規格ですのでメーカーや楽器の種類が違ってもデータをやりとることができます。

MIDIでは、「鍵盤を弾く」、「音色を選ぶ」といった演奏に関する情報以外に、画面を切り替える為の情報や、テンポをコントロールするための情報など、さまざまな情報をやりとることができます。これらの情報をフルに活用すると、鍵盤やコントローラーを使って演奏するだけではなく、パートごとのパンやバープの深さを変えたり、エフェクトやEGの設定を変更するなど、本体パネルで設定するパラメーターのほとんどを外部MIDI機器からMIDIを通してコントロールすることができます。

MIDIチャンネル

MIDIの情報には、MIDIチャンネルという1-16の番号が割り当てられています。このMIDIチャンネルを使って、1本のMIDIケーブルで同時に16チャンネル分の情報を送る仕組みになっています。たとえば、コンピューターやシーケンサーで多くのパートを使った演奏をMIDIを使って送信する場合、受け手側の機器では、受信したいチャンネル(各パートのMIDI受信チャンネル)を設定することで、16チャンネルの信号の中から特定のチャンネルの信号だけを選んで受信することができます。極端な例ですが、16台の音源を用意して、それぞれMIDI受信チャンネルを1-16に設定すると、シーケンサーから1本のMIDIケーブルを通して送信された演奏情報は各音源で別々に再生されることになります。

S30のように、1台で複数の音源パートを持ち、パートごとに異なったMIDIチャンネルを設定して同時に複数パートの演奏できる音源をマルチ音源と呼びます。マルチ音源を使うと、上記のような演奏は1台で可能になります。

S30で送受信できるMIDI情報

MIDI情報は、大きく分けてチャンネルメッセージとシステムメッセージの2つのタイプがあります。

チャンネルメッセージ

チャンネルメッセージは、チャンネルごとに個別に送られる、演奏についての情報のことです。それぞれのタイプには以下のようなメッセージがあります。

ノートオン/オフ:

鍵盤の演奏情報を伝えます。

コントロールチェンジ:

ボリュームやパンなどをコントロールするメッセージです。いろいろな種類のコントロールチェンジには、それぞれコントロールナンバーが付いています。

プログラムチェンジ:

ボイスを選択するためのMIDIメッセージです。コントロールチェンジのバンクセレクトと組み合わせで使用します。

チャンネルアフタータッチ:

鍵盤を弾いた後、更に押さえつける強さを伝えて、音に変化をつけるMIDIメッセージです。外部機器から受信することができます。

ポリフォニックキープレッシャー:

各鍵盤ごとに、鍵盤を弾いた後の更に押さえつける強さを伝えるMIDIメッセージです。内蔵シーケンサーから送信することができます。

ピッチベンド:

ピッチベンドホイールの演奏を伝えて、ピッチを変化させるMIDIメッセージです。

チャンネルメッセージには、この他にローカルコントロールやオール ノート オフなどのモードメッセージがあります。

システムメッセージ

システムメッセージは、機器間の同期などシステム全体に関連した設定を行う情報です。

エクスクルーシブメッセージ

メーカー固有のメッセージで、シーケンスデータやパラメーターチェンジなどを送受信します。このMIDIメッセージを使うと、外部MIDI機器からS30のほとんどすべての設定をエディットすることも可能になります。

リアルタイムメッセージ

スタート、ストップ、コンティニュー、MIDIクロック、アクティブセンシングなど、シーケンサーをコントロールするメッセージです。

リコンメッセージ

リアルタイムメッセージ同様、シーケンサーをコントロールするメッセージで、ソングセレクト、ソングポジション ポインターがあります。

MIDIデータフォーマット

「MIDIデータフォーマット」は、データ/値を10進数や2進数、16進数で表現しています。16進数の場合は数値の後(または列の頭)にH (Hexadecimal)が付いています。

また、「n」は任意の整数を表します。データ/値を入力する場合は、以下のテーブルをご参照ください。

10進	16進	2進
0	00	0000 0000
1	01	0000 0001
2	02	0000 0010
3	03	0000 0011
4	04	0000 0100
5	05	0000 0101
6	06	0000 0110
7	07	0000 0111
8	08	0000 1000
9	09	0000 1001
10	0A	0000 1010
11	0B	0000 1011
12	0C	0000 1100
13	0D	0000 1101
14	0E	0000 1110
15	0F	0000 1111
16	10	0001 0000
17	11	0001 0001
18	12	0001 0010
19	13	0001 0011
20	14	0001 0100
21	15	0001 0101
22	16	0001 0110
23	17	0001 0111
24	18	0001 1000
25	19	0001 1001
26	1A	0001 1010
27	1B	0001 1011
28	1C	0001 1100
29	1D	0001 1101
30	1E	0001 1110
31	1F	0001 1111
32	20	0010 0000
33	21	0010 0001
34	22	0010 0010
35	23	0010 0011
36	24	0010 0100
37	25	0010 0101
38	26	0010 0110
39	27	0010 0111
40	28	0010 1000
41	29	0010 1001
42	2A	0010 1010
43	2B	0010 1011
44	2C	0010 1100
45	2D	0010 1101
46	2E	0010 1110
47	2F	0010 1111
48	30	0011 0000
49	31	0011 0001
50	32	0011 0010
51	33	0011 0011
52	34	0011 0100
53	35	0011 0101
54	36	0011 0110
55	37	0011 0111
56	38	0011 1000
57	39	0011 1001
58	3A	0011 1010
59	3B	0011 1011
60	3C	0011 1100
61	3D	0011 1101
62	3E	0011 1110
63	3F	0011 1111

10進	16進	2進
64	40	0100 0000
65	41	0100 0001
66	42	0100 0010
67	43	0100 0011
68	44	0100 0100
69	45	0100 0101
70	46	0100 0110
71	47	0100 0111
72	48	0100 1000
73	49	0100 1001
74	4A	0100 1010
75	4B	0100 1011
76	4C	0100 1100
77	4D	0100 1101
78	4E	0100 1110
79	4F	0100 1111
80	50	0101 0000
81	51	0101 0001
82	52	0101 0010
83	53	0101 0011
84	54	0101 0100
85	55	0101 0101
86	56	0101 0110
87	57	0101 0111
88	58	0101 1000
89	59	0101 1001
90	5A	0101 1010
91	5B	0101 1011
92	5C	0101 1100
93	5D	0101 1101
94	5E	0101 1110
95	5F	0101 1111
96	60	0110 0000
97	61	0110 0001
98	62	0110 0010
99	63	0110 0011
100	64	0110 0100
101	65	0110 0101
102	66	0110 0110
103	67	0110 0111
104	68	0110 1000
105	69	0110 1001
106	6A	0110 1010
107	6B	0110 1011
108	6C	0110 1100
109	6D	0110 1101
110	6E	0110 1110
111	6F	0110 1111
112	70	0111 0000
113	71	0111 0001
114	72	0111 0010
115	73	0111 0011
116	74	0111 0100
117	75	0111 0101
118	76	0111 0110
119	77	0111 0111
120	78	0111 1000
121	79	0111 1001
122	7A	0111 1010
123	7B	0111 1011
124	7C	0111 1100
125	7D	0111 1101
126	7E	0111 1110
127	7F	0111 1111

追加ノート

・上記のテーブル以外でも、たとえば、144-159 (10進数)/9nH/10010000 ~ 10011111 (2進数)は、それぞれ(1-16)チャンネルごとのノートオンメッセージを示します。176-191/BnH/10110000 ~ 10111111は、それぞれ(1-16)チャンネルごとのコントロールチェンジメッセージを示します。192-207/CnH/11000000 ~ 11001111は、それぞれ(1-16)チャンネルごとのプログラムチェンジメッセージを示します。240/FOH/111100000はシステムエクスクルーシブメッセージの始まりを示します。247/F7H/11110111はシステムエクスクルーシブメッセージの終わりを示します。

・aaH (16進数)/Oaaaaaaa (2進数)はデータのアドレスを示します。アドレスは、High、MidとLowがあります。

・bbH/0bbbbbbbはバイトカウントを示します。

・ccH/0cccccccはチェックサムを示します。

・ddH/0dddddddはデータ/値を示します。

シンセサイザー/シーケンサーパート

(1) TRANSMIT FLOW

MIDI <-[SW1]-	----	NOTE ON/OFF	9nH
OUT			
		----	CONTROL CHANGE
		+--[SW8]--	BANK SEL MSB BnH,00H
			BANK SEL LSB BnH,20H
			MODULATION BnH,01H
			ASSIGNABLE CONTROLLER BnH,(00H .. 5FH)
		----	PROGRAM CHANGE CnH
		----	CHANNEL AFTER TOUCH DnH
		----	PITCH BEND CHANGE EnH
		-[SW3,4]--	SYSTEM REALTIME MESSAGE
			TIMING CLOCK F8H
		-[SW4]----	SYSTEM REALTIME MESSAGE
			START FAH
			CONTINUE FBH
			STOP FCH
		+ [SW5]-	SYSTEM EXCLUSIVE MESSAGE
			-[SW7]- <BULK DUMP> FOH 43H 0nH 64H bhH blH ahH amH alH ddH....ddH ccH F7H
			-[SW7]- <PARAMETER CHANGE> FOH 43H lnH 64H ahH amH alH ddH....ddH F7H
		-----	SYSTEM EXCLUSIVE MESSAGE
			IDENTITY REPLY FOH 7EH 7FH 06H 02H 43H 00H 41H ddH ddH 00H 00H 7FH F7H
		-----	ACTIVE SENSING FEH
[SW1]		MIDI Transmit Channel	
		Master Keyboard Mode = on	では、Zone Transmit Channel に従う。
		Master Keyboard Mode = off	では、Keyboard Transmit Channel に従う。
		シーケンサー部から再生されるデータは、[SW1]にかかわらず、シーケンスデータの Channel	で出力する。
[SW3]		MIDI Sync	
[SW4]		MIDI Control	
[SW5]		MIDI Device Number	
		allのときは、1で送信される。	
[SW7]		VOICE MODE	では、VOICE のもののみ。 PERFORMANCE MODE
		SYSTEM	はどのモードでも送受信。
[SW8]		SYSTEM Bank Select Switch	

(2) RECEIVE FLOW

MIDI >-[SW11]	----	NOTE OFF	8nH
		----	NOTE ON/OFF
			9nH
		----	CONTROL CHANGE
			MODULATION BnH,01H
			PORTAMENTO TIME BnH,05H
			DATA ENTRY MSB BnH,06H
			DATA ENTRY LSB BnH,26H
			MAIN VOLUME BnH,07H
			PAN BnH,0AH
			EXPRESSION BnH,0BH
			SUSTAIN SWITCH BnH,40H
			PORTAMENTO SWITCH BnH,41H
			SOSTENUTO BnH,42H
			HARMONIC CONTENT BnH,47H
			EG RELEASE TIME BnH,48H
			EG ATTACK TIME BnH,49H
			BRIGHTNESS BnH,4AH
			EG DECAY TIME BnH,4BH
			EFFECT1 DEPTH BnH,5BH
			EFFECT2 DEPTH BnH,5DH
			DATA ENTRY INC BnH,60H
			DATA ENTRY DEC BnH,61H
			ASSIGNABLE CONTROLLER BnH,(00H .. 5FH)
			RPN
			PITCH BEND SENS BnH,64H,00H,65H,00H,06H,mmH
			FINE TUNING BnH,64H,01H,65H,00H,06H,mmH,26H,11H *1
			COARSE TUNING BnH,64H,02H,65H,00H,06H,mmH *1
			RPN RESET BnH,64H,7FH,65H,7FH
			ALL SOUND OFF BnH,78H
			RESET ALL CONTROLLERS BnH,79H
			ALL NOTE OFF BnH,7BH
			OMNI MODE OFF BnH,7CH
			OMNI MODE ON BnH,7DH
			MONO MODE BnH,7EH
			POLY MODE BnH,7FH
		--[SW8]--	BANK SEL MSB BnH,00H
			BANK SEL LSB BnH,20H
		--[SW9]--	PROGRAM CHANGE CnH
		-----	CHANNEL AFTER TOUCH DnH
		-----	PITCH BEND CHANGE EnH
		-----	SYSTEM EXCLUSIVE MESSAGE
			IDENTITY REQUEST FOH 7EH 0nH 06H 01H F7H
			REMOTE SWITCH FOH 43H 10H 64H 0AH 00H alH ddH F7H
		--[SW12]-	GM MODE ON FOH 7EH 7FH 09H 01H F7H
		+ [SW5]-	SYSTEM EXCLUSIVE MESSAGE
			MIDI MASTER VOLUME FOH 7FH 7FH 04H 01H 11H mmH F7H
		--[SW10]-	<BULK DUMP> FOH 43H 0nH 64H bhH blH ahH amH alH ddH....ddH ccH F7H
		--[SW7]--	<PARAMETER CHANGE> FOH 43H lnH 64H ahH amH alH ddH....ddH F7H
		--[SW7]--	<BULK DUMP REQUEST> FOH 43H 2nH 64H ahH amH alH ddH....ddH F7H
		--[SW7]--	<PARAMETER REQUEST> FOH 43H 3nH 64H ahH amH alH F7H
		--[SW12]-	XG SYSTEM ON FOH 43H lnH 4CH 00H 00H 7EH 00H F7H
		+ [SW3]-----	SYSTEM REALTIME MESSAGE
			TIMING CLOCK F8H
		+ [SW4]-----	SYSTEM REALTIME MESSAGE
			START FAH
			CONTINUE FBH
			STOP FCH
		-----	ACTIVE SENSING FEH
[SW2]		MIDI Sync	
[SW4]		MIDI Control	
[SW5]		MIDI Device Number	
		MIDI MASTER VOLUME	は、Device Number = off 以外では常に受信する。
[SW7]		VOICE MODE	では、VOICE のもののみ。 PERFORMANCE MODE
		SYSTEM	のものとはどのモードでも送受信。
[SW8]		SYSTEM Bank Select Switch	
[SW9]		SYSTEM Program Change Switch (Voice Mode	では、Play Mode でのみ受信。)
[SW10]		SYSTEM Bulk Protect	および SW7 の条件。
[SW11]		MIDI Receive Channel	および Receive Filter
		Performance Mode	では、Part Receive Channel
		Performance Mode	以外では、Basic Receive Channelに従う。
[SW12]		SYSTEM Receive GM/XG On	

*1 パフォーマンスモードのみ

(3) TRANSMIT/RECEIVE DATA

(3-1) CHANNEL VOICE MESSAGES

(3-1-1) NOTE OFF

STATUS 1000nnnn(8nH) n = 0 ~ 15 CHANNEL NUMBER
NOTE NUMBER 0kkkkkkkk k = 0 (C-2) ~ 127 (G8)
VELOCITY 0vvvvvvv v は無視
受信のみ行なう。

(3-1-2) NOTE ON/OFF

STATUS 1001nnnn(9nH) n = 0 ~ 15 CHANNEL NUMBER
NOTE NUMBER 0kkkkkkkk k = 0 (C-2) ~ 127 (G8)
VELOCITY 0vvvvvvv(v=0) NOTE ON
0vvvvvvv(v=0) NOTE OFF

(3-1-3) CONTROL CHANGE

STATUS 1011nnnn(8nH) n = 0 ~ 15 CHANNEL NUMBER
CONTROL NUMBER 0ccccccc c = CONTROL NUMBER
CONTROL VALUE 0vvvvvvv v = DATA VALUE

* 送信する CONTROL NUMBER
c = 0 BANK SEL MSB ; v = 0,63,127 *3
c = 32 BANK SEL LSB ; v = 0,1,8,9,24,25,32,40,41,64,65 *3
c = 1 MODULATION ; v = 0 ~ 127
c = 0.95 ASSIGNABLE CONTROLLER ; v = 0 ~ 127 *6

シーケンサー部からは、記録されているすべてのコントロールチェンジ情報を再生する。

* 受信する CONTROL NUMBER
c = 0 BANK SEL MSB ; v = 0 ~ 127 *3
c = 32 BANK SEL LSB ; v = 0 ~ 127 *3
c = 1 MODULATION ; v = 0 ~ 127
c = 5 PORTAMENTO TIME ; v = 0 ~ 127 *2
c = 6 DATA ENTRY MSB ; v = 0 ~ 127 *1
c = 38 DATA ENTRY LSB ; v = 0 ~ 127 *1
c = 7 MAIN VOLUME ; v = 0 ~ 127
c = 10 PAN ; v = 0 ~ 127
c = 11 EXPRESSION ; v = 0 ~ 127
c = 31 EG SUSTAIN LEVEL ; v = 0:-64 - 64:0 - 127:+63 *2,*5
c = 64 SUSTAIN SWITCH ; v = 0-63:OFF, 64-127:ON *2
c = 65 PORTAMENTO SWITCH ; v = 0-63:OFF, 64-127:ON *2
c = 66 SOSTENUTO ; v = 0-63:OFF, 64-127:ON *2
c = 71 HARMONIC CONTENT ; v = 0:-64 - 64:0 - 127:+63
c = 72 EG RELEASE TIME ; v = 0:-64 - 64:0 - 127:+63 *2
c = 73 EG ATTACK TIME ; v = 0:-64 - 64:0 - 127:+63
c = 74 BRIGHTNESS ; v = 0:-64 - 64:0 - 127:+63
c = 75 EG DECAY TIME ; v = 0:-64 - 64:0 - 127:+63
c = 91 EFFECT1 DEPTH ; v = 0 ~ 127
c = 93 EFFECT3 DEPTH ; v = 0 ~ 127
c = 96 DATA ENTRY INC ; v = 127 *1
c = 97 DATA ENTRY DEC ; v = 127 *1
c = 0.95 ASSIGNABLE CONTROLLER ; v = 0 ~ 127 *6
c = 0.95 ARPEGGIO SW ; v = 0-63:OFF, 64-127:ON *6
c = 0.95 ARPEGGIO HOLD ; v = 0-63:OFF, 64-127:ON *6

*1 RPN で指定パラメーターを設定するときのみ用いる。

*2 Drum Voice に対しては無効。

*3 BANK CHANGE と PROGRAM の関係

Table with columns: CATEGORY, MSB, LSB, PROGRAM No., and values for Normal Voice, Drum Voice, Plug-in Voice, Performance.

*5 CONTROL CHANGE MODE を MODE2 としている場合のみ受信する。

*6 ASSIGNABLE CONTROLLER の DEFAULT CONTROL NUMBER は、

Table with columns: CONTROLLER NAME and VALUE, listing FOOT CONTROLLER, KNOB 1-3, KNOB A-C, RIBBON CONTROLLER, CONTROL SLIDER, FOOT SWITCH, ARPEGGIO HOLD, ARPEGGIO SWITCH.

PORTAMENTO TIMEは、Portamento Switch = ON のときのピッチ変化速度を調節する。

0 でポルタメント最短時間、127 でポルタメント最長時間となる。

PAN は、音色のプリセット値に対して相対的に変化する。

EFFECT1 DEPTHは、リバーセンドをコントロールする。

EFFECT3 DEPTHは、コーラスセンドをコントロールする。

HARMONIC CONTENTは、音色で設定されているレゾナンスを調節する。

相対変化のパラメーターであるため、64 を基準として増減の指定をする。

値が大きくなるほどクセのある音になる。音色により、効果のある範囲が設定できる範囲より狭い場合がある。

EG ATTACK TIME, EG DECAY TIME, EG SUSTAIN LEVEL, EG RELEASE TIMEは、音色で設定されているエンベロープを調節する。相対変化のパラメーターであるため、64 を基準として増減の指定をする。

BRIGHTNESSは、音色で設定されているカットオフ周波数を調節する。

相対変化のパラメーターであるため、64 を基準として増減の指定をする。

値が小さくなるほどカットオフ周波数が低くなる。音色により、効果のある範囲が設定できる範囲より狭い場合がある。

Bank Selectの動作は、すべてProgram Changeを受信したとき発生する。

Bank Select、Program Change は、サポートしている番号以外のものは無視する。

(3-1-4) PROGRAM CHANGE

STATUS 1100nnnn(CnH) n = 0 ~ 15 CHANNEL NUMBER
PROGRAM NUMBER 0pppppppp p = 0 ~ 127

(3-1-5) CHANNEL AFTER TOUCH

STATUS 1101nnnn(DnH) n = 0 ~ 15 CHANNEL NUMBER
VALUE 0vvvvvvv v = 0 ~ 127 AFTER TOUCH VALUE

(3-1-6) PITCH BEND CHANGE

STATUS 1110nnnn(EnH) n = 0 ~ 15 CHANNEL NUMBER
LSB 0vvvvvvv PITCH BEND CHANGE LSB
MSB 0vvvvvvv PITCH BEND CHANGE MSB
送信の分解能は7 bit。

(3-2) CHANNEL MODE MESSAGES

STATUS 1011nnnn(8nH) n = 0 ~ 15 CHANNEL NUMBER
CONTROL NUMBER 0ccccccc c = CONTROL NUMBER
CONTROL VALUE 0vvvvvvv v = DATA VALUE

(3-2-1) ALL SOUND OFF (CONTROL NUMBER = 78H, DATA VALUE = 0)

該当チャンネルの発音中の音をすべて消音する。ノート・オンやホールド・オンなどのチャンネルメッセージの状態も消去する。

(3-2-2) RESET ALL CONTROLLERS (CONTROL NUMBER = 79H, DATA VALUE = 0)

以下のコントローラーの設定値をリセットする。

PITCH BEND CHANGE 0 (中央)
CHANNEL AFTER TOUCH 0 (最小)
MODULATION 0 (最小)
EXPRESSION 127 (最大)
FOOT CONTROLLER 127 (最大)
KNOB 1 0 (中央)
KNOB 2 0 (中央)
SUSTAIN SWITCH 0 (オフ)
SOSTENUTO SWITCH 0 (オフ)
RPN 番号未設定状態、内部データは変化しない

以下の各データは変更しない。

PROGRAM CHANGE, BANK SELECT MSB/LSB, VOLUME, PAN, HARMONIC CONTENT, SUSTAIN LEVEL, RELEASE TIME, ATTACK TIME, DECAY TIME, BRIGHTNESS, EFFECT SEND LEVEL 1, EFFECT SEND LEVEL 3, PORTAMENTO SWITCH, PITCH BEND SENSITIVITY, FINE TUNING, COARSE TUNING, ASSIGNABLE CONTROLLER

(3-2-3) ALL NOTE OFF (CONTROL NUMBER = 7BH, DATA VALUE = 0)

該当チャンネルのオンしているノートをすべてオフする。ただし、サステイン、あるいはソステヌートがオンの場合は、それらがオフになるまで発音は終了しない。

(3-2-4) OMNI MODE OFF (CONTROL NUMBER = 7CH, DATA VALUE = 0)

ALL NOTE OFF を受信したときと同じ処理を行なう。VOICE RECEIVE CHANNELを、OMNI OFFで、CHANNEL=1とする。

(3-2-5) OMNI MODE ON (CONTROL NUMBER = 7DH, DATA VALUE = 0)

ALL NOTE OFF を受信したときと同じ処理を行なう。VOICE RECEIVE CHANNELを、OMNI ONにする。

(3-2-6) MONO (CONTROL NUMBER = 7EH, DATA VALUE = 0.16)

オール・サウンド・オフを受信したときと同じ処理を行ない、3rd byte (モノ数) が 0 ~ 16 の範囲内にあれば該当チャンネルを Mode4(m = 1) にする

VOICE MODEなら、VOICE RECEIVE CHANNELに従って、Mode2(m=1)にもなり得る。

(3-2-7) POLY (CONTROL NUMBER = 7FH, DATA VALUE = 0)

オール・サウンド・オフを受信したときと同じ処理を行ない、該当チャンネルをMode3 にする。VOICE MODEなら、VOICE RECEIVE CHANNELに従って、Mode1にもなり得る。

(3-3) REGISTERED PARAMETER NUMBER

STATUS 1011nnnn(8nH) n = 0 ~ 15 CHANNEL NUMBER
LSB 01100100(64H)
RPN LSB 0pppppppp p = RPN LSB (下表参照)
MSB 01100101(65H)
RPN MSB 0qqqqqqqq q = RPN MSB (下表参照)
DATA ENTRY MSB 00000110(06H)
DATA VALUE 0mmmmmm m = Data Value
DATA ENTRY LSB 00100110(26H)
DATA VALUE 01111111 1 = Data Value

まず RPN MSB と RPN LSB を与えて制御するパラメーターを指定し、その後データ・エントリーで指定パラメーターの値を設定する。

Table with columns: RPN, D.ENTRY, LSB MSB MSB LSB PARAMETER NAME, DATA RANGE

00H 00H mmH --- PITCH BEND SENSITIVITY 00H ~ 18H (0 ~ 24 半音)
01H 00H mmH 11H MASTER FINE TUNE (mmH,11H)=[00H,00H]-[40H,00H]-[7FH,7FH] (-8192*100/8192) ~ 0 ~ (+8192*100/8192)
02H 00H mmH --- MASTER COARSE TUNE 28H ~ 40H = 58H (-24 ~ 0 ~ +24 半音)
7FH 7FH --- RPN RESET RPN番号が指定されていない状態になる。内部の設定値は変化しない。

(3-4) NON-REGISTERED PARAMETER NUMBER

制御できるパラメーターはなし。

(3-5) SYSTEM REAL TIME MESSAGES

(3-5-1) ACTIVE SENSING

STATUS 11111110(FEH)

約 200 msec ごとに送信する。

この CODE を一度受信すると、SENSINGを開始する。約 350 msec 以上の間、

STATUS も DATA も来ないときは、MIDI 受信 BUFFER を CLEAR し、発音している音と SUSTAIN SWITCH を強制的に OFF する。また、各 Control 情報の値 は特定値にリセットする。

(3-6) SYSTEM EXCLUSIVE MESSAGE

(3-6-1) UNIVERSAL NON REALTIME MESSAGE

(3-6-1-1) GENERAL MIDI MODE ON

FOH 7EH 7FH 09H 01H F7H
 PERFORMANCE MODE で SYSTEM Receive GM/XG on がオンの場合のみ受信し、SYSTEM Internal Part の設定に従って、Part の設定値をリセットする。

(3-6-1-2) IDENTITY REQUEST (受信のみ)

FOH 7EH 0nH 06H 01H F7H (nは、Device No.だが、本機はomniで受信する)

(3-6-1-3) IDENTITY REPLY (送信のみ)

FOH 7EH 7FH 06H 02H 43H 00H 41H ddH ddH 00H 00H 7FH F7H
 dd:Device Number Code: 23 04

(3-6-2) UNIVERSAL REALTIME MESSAGE

(3-6-2-1) MIDI MASTER VOLUME

FOH 7FH 7FH 04H 01H 11H mmH F7H
 MASTER VOLUME の値を変更する。
 mm の値をMIDI マスターボリューム値として用いる。(11 の値は無視)

(3-6-3) PARAMETER CHANGE

(3-6-3-1) XG SYSTEM ON

11110000	F0	Exclusive status
1000011	43	YAMAHA ID
0001nnnn	1n	device Number
1001100	4C	Model ID
0aaaaaaa	0	Address High
0aaaaaaa	0	Address Mid
0aaaaaaa	7E	Address Low
0	0	Data
11110111	F7	End of Exclusive

PERFORMANCE MODE で SYSTEM Receive GM/XG on がオンの場合のみ受信し、SYSTEM Internal Part の設定に従って、Part の設定値をリセットする。
 このメッセージの実行には、約170ms かかるため、次のメッセージとの間隔を注意すること。

(3-6-3-2) NATIVE PARAMETER CHANGE, REMOTE SWITCH

11110000	F0	Exclusive status
01000011	43	YAMAHA ID
0001nnnn	1n	device Number
01100100	64	Model ID
0aaaaaaa	aaaaaaa	Address High
0aaaaaaa	aaaaaaa	Address Mid
0aaaaaaa	aaaaaaa	Address Low
0ddddd	ddddd	Data
11110111	F7	End of Exclusive

Data Sizeが2以上のパラメーターはそのSize分データを送信する。
 Address および Byte Count は、付表を参照すること。
 REMOTE SWITCH では、device number はいずれの値でも受信する。

(3-6-4) BULK DUMP

11110000	F0	Exclusive status
01000011	43	YAMAHA ID
0000nnnn	0n	device Number
01100100	64	Model ID
0bbbbbbb	bbbbbbb	Byte Count
0bbbbbbb	bbbbbbb	Byte Count
0aaaaaaa	aaaaaaa	Address High
0aaaaaaa	aaaaaaa	Address Mid
0aaaaaaa	aaaaaaa	Address Low
0	0	Data
0ccccccc	ccccccc	Check-sum
11110111	F7	End of Exclusive

Address および Byte Count は、付表を参照すること。
 Check sum は、Byte Count, Start Address, Data, Check-sum 自身を加算した値の下位 7bit がゼロになる値である。

(3-6-5) DUMP REQUEST

11110000	F0	Exclusive status
01000011	43	YAMAHA ID
0010nnnn	2n	device Number
01100100	64	Model ID
0aaaaaaa	aaaaaaa	Address High
0aaaaaaa	aaaaaaa	Address Mid
0aaaaaaa	aaaaaaa	Address Low
11110111	F7	End of Exclusive

Address および Byte Count は、付表を参照すること。

(3-6-6) PARAMETER REQUEST

11110000	F0	Exclusive status
01000011	43	YAMAHA ID
0010nnnn	3n	device Number
01100100	64	Model ID
0aaaaaaa	aaaaaaa	Address High
0aaaaaaa	aaaaaaa	Address Mid
0aaaaaaa	aaaaaaa	Address Low
11110111	F7	End of Exclusive

Address および Byte Count は、付表を参照すること。

(4) 鍵盤スイッチ部、SEQUENCER 部と、音源部との構成図

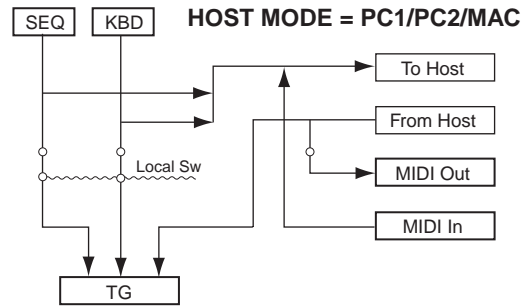
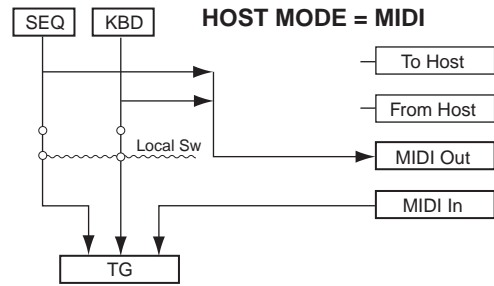

ノートオン、ノートオフについては、MIDIで受信したものと、本体シーケンサーで演奏されたものと、本体鍵盤で演奏されたものとは区別されるが、他のコントローラーは、MIDI、本体の区別なく効果がすべてのノートにかかる。

ALL SOUND OFFは、MIDI、本体の区別なく、該当チャンネルのすべての発音を消去する。
 MIDI で受信した ALL NOTE OFF は該当チャンネルで MIDIにより発音されたノートのみをオフする。

MIDIデータテーブル

Bank Select

送受信可能なバンクセレクト/プログラムチェンジ

MSB (HEX)	LSB (HEX)	Program No.	Type	Memory	Description	
0	00	0	00	0 - 127	Normal Voice Internal	
127	7F	0	00	0 - 1	Drum Voice User(Internal)	
63	3F	0	00	0 - 127	Normal Voice Preset 1 システム (ユーティリティモード) のMIDI Swのページの 設定に依存する。詳しくは取扱説明書を参照。	
		1	01	0 - 127		
		8	08	0 - 127		
		9	09	0 - 127		
	25	19	0	63	Plug-in Voice User(Plug-in)	
			32	20		0 - 7
			40	28		0 - 1
			41	29		0 - 1
63	3F	64	40	0 - 127	Performance User(Internal)	
		65	41			0 - 127

Plug-in Voice Bank Display

Plug-in Board 装着時に Voice Mode(PLGが選択された状態)で選択できるボイスのバンク

MSB (HEX)	LSB (HEX)	Program No.	Type	LCD Display	Description
63	3F	18 - 19	0 - 63	Internal	PLG_INT LSB = 25H: Plug-in
0	00	00 - 7F	0 - 127	XG Normal	NORM/LLL LLL: Bank LSB
64	40	00 - 7F	0 - 127	XG SFX	NORM/SFX
126	7E	00 - 7F	0 - 127	XG SFX kit	KIT/SFX
127	7F	00 - 7F	0 - 127	XG Drum kit	KIT/DRM
***	**	00 - 7F	0 - 127	others	MMM/LLL MMM: Bank MSB, LLL: Bank LSB

Internal以外は、Plug-in Boardが受信可能なバンクのみを表示。

<付表 1 >

Parameter Base Address

Parameter Block	Top Address			Description
	H	M	L	
SYSTEM	00	00	00	System
	00	10	00	Plug-in Board Native System
	00	20	00	Master EQ
	00	70	00	Panel Knob
REMOTE SWITCH	0A	00	00	Remote Switch
BULK CONTROL	0E	00	00	Header
	0F	00	00	Footer
PERFORMANCE COMMON	30	00	00	Performance Common
PERFORMANCE PART	31	00	00	Part1
	:	:	:	:
	31	0F	00	Part16
PERFORMANCE PLUG-IN PART	31	61	00	Plug-in Part
	32	00	00	Zone1
PERFORMANCE MASTER KEYBOARD ZONE	:	:	:	:
	32	03	00	Zone4
VOICE COMMON	40	00	00	Common
	40	01	00	Reverb
	40	02	00	Chorus
	40	03	00	Insertion 1
	40	04	00	Insertion 2
	40	05	00	Controller
	40	06	00	LFO
	40	70	00	Extra
VOICE ELEMENT GROUP1	41	ee	00	ee : Element No.
VOICE ELEMENT GROUP2	42	ee	00	ee : Element No.
VOICE ELEMENT GROUP3	43	ee	00	ee : Element No.
VOICE ELEMENT GROUP4	44	ee	00	ee : Element No.
KIT COMMON (DRUM VOICE)	46	00	00	Common
	46	01	00	Reverb
	46	02	00	Chorus
	46	03	00	Insertion 1
	46	04	00	Insertion 2
	46	05	00	Controller
	46	70	00	Extra
KIT ELEMENT GROUP1	47	ee	00	ee : Element No.
KIT ELEMENT GROUP2	48	ee	00	ee : Element No.
KIT ELEMENT GROUP3	49	ee	00	ee : Element No.
KIT ELEMENT GROUP4	4A	ee	00	ee : Element No.
VOICE PLUG-IN	4C	00	00	Common
	4C	01	00	Reverb
	4C	02	00	Chorus
	4C	03	00	Insertion 1
	4C	05	00	Controller
	4C	10	00	Plug-in Element
	4C	20	00	Native
	4C	70	00	Extra

<付表 2 >

Bulk Dump Block

Top Address は、Bulk Dump で指定されるブロックの先頭アドレスを示します。Byte Count は、Bulk Dump のブロックに含まれるデータサイズを示します。

PERFORMANCE および VOICE の Bulk Header から Bulk Footer までの Block は、順序は関係なく、すべて揃わなくても受信します。ただし、本来含まれない Block が割り込んだ場合は、無効となります。1 Performance / 1 Voice のリクエストは、対応する Bulk Header のアドレスを指定してください。以下の表の Bulk Header の部分の mm, nn については、MIDI PARAMETER CHANGE TABLE (BULK CONTROL)を参照してください。

Parameter Block	Description	Byte Count	Top Address		
			Dec	Hex	H M L
SYSTEM	System	60 3C	00	00	00
	Plug-in Board Native System	32 20	00	10	00
	Master EQ (for Voice Mode)	20 14	00	20	00

Parameter Block	Description	Byte Count	Top Address		
			Dec	Hex	H M L
PERFORMANCE COMMON	Bulk Header	0 00	0E	mm	nn
	Common	68 44	30	00	00
	Reverb	24 18	30	01	00
	Chorus	25 19	30	02	00
	Master EQ	20 14	30	10	00
	Native (for InsEF Plug-in)	68 44	30	20	00
	Part1	37 25	31	0F	00
	:	16 Blocks	:	:	:
	Part16	37 25	31	0F	00
	PLUG-IN PART	Plug-in Part	37 25	31	61
MASTER KEYBOARD ZONE	Zone1	16 10	32	00	00
	:	4 Blocks	:	:	:
	Zone4	16 10	32	03	00
	Bulk Footer	0 00	0F	mm	nn

Parameter Block	Description	Byte Count	Top Address		
			Dec	Hex	H M L
VOICE (NORMAL) COMMON	Bulk Header	0 00	0E	mm	nn
	Extra	56 38	40	70	00
	Common	13 0D	40	00	00
	Reverb	24 18	40	01	00
	Chorus	25 19	40	02	00
	Insertion 1(S)	22 16	40	03	00
	Insertion 2(L)	34 22	40	04	00
	Controller	30 1E	40	05	00
	LFO	14 0E	40	06	00
	ELEMENT 1	Oscillator	13 0D	41	00
Amplitude		29 1D	41	00	20
Pitch		27 1B	42	00	00
Filter		48 30	43	00	00
EQ		8 08	44	00	00
LFO		6 06	44	00	40
ELEMENT 2	Oscillator	13 0D	41	01	00
	Amplitude	29 1D	41	01	20
	Pitch	27 1B	42	01	00
	Filter	48 30	43	01	00
	EQ	8 08	44	01	00
	LFO	6 06	44	01	40
ELEMENT 3	Oscillator	13 0D	41	02	00
	Amplitude	29 1D	41	02	20
	Pitch	27 1B	42	02	00
	Filter	48 30	43	02	00
	EQ	8 08	44	02	00
	LFO	6 06	44	02	40
ELEMENT 4	Oscillator	13 0D	41	03	00
	Amplitude	29 1D	41	03	20
	Pitch	27 1B	42	03	00
	Filter	48 30	43	03	00
	EQ	8 08	44	03	00
	LFO	6 06	44	03	40
Bulk Footer	0 00	0F	mm	nn	

Parameter Block	Description	Byte Count	Top Address		
			Dec	Hex	H M L
VOICE (DRUM) COMMON	Bulk Header	0 00	0E	mm	nn
	Extra	56 38	46	70	00
	Common	7 07	46	00	00
	Reverb	24 18	46	01	00
	Chorus	25 19	46	02	00
	Insertion 1(S)	22 16	46	03	00
	Insertion 2(L)	34 22	46	04	00
	Controller	30 1E	46	05	00
	Oscillator	18 12	47	00	00
	Amplitude	12 0C	47	00	20
KEY C 0	Pitch	3 03	48	00	00
	Filter	8 08	49	00	00
	EQ	8 08	4A	00	00
	:	73 Blocks	:	:	:
KEY C 6	Oscillator	18 12	47	48	00
	Amplitude	12 0C	47	48	20
	Pitch	3 03	48	48	00
	Filter	8 08	49	48	00
	EQ	8 08	4A	48	00
Bulk Footer	0 00	0F	mm	nn	

VOICE (PLUG-IN)		Bulk Header	0 00	0E	mm	nn
COMMON	Extra	56 38	4C	70	00	
	Common	13 0D	4C	00	00	
	Reverb	24 18	4C	01	00	
	Chorus	25 19	4C	02	00	
	Insertion 1(S)	22 16	4C	03	00	
	Controller	10 0A	4C	05	00	
	Plug-in Element	35 23	4C	10	00	
Native	68 44	4C	20	00		
Bulk Footer		0 00	0F	mm	nn	

Parameter Change

F0, 43, 1n, id, ah, am, al, dt, ..., F7

n: Device Number
 id: Model ID
 ah: Parameter Address High
 am: Parameter Address Middle
 al: Parameter Address Low
 dt: Data

Parameter Request

F0, 43, 3n, id, ah, am, al F7

n: Device Number
 id: Model ID
 ah: Parameter Address High
 am: Parameter Address Middle
 al: Parameter Address Low

Bulk Dump

F0, 43, 0n, id, bh, bl, ah, am, al, dt, ..., cc, F7

n: Device Number
 id: Model ID
 bh: Byte Count High
 bl: Byte Count Low
 ah: Parameter Address High
 am: Parameter Address Middle
 al: Parameter Address Low
 dt: Data
 cc: Check Sum of Data

Bulk Dump Request

F0, 43, 2n, id, ah, am, al, F7

n: Device Number
 id: Model ID
 ah: Parameter Address High
 am: Parameter Address Middle
 al: Parameter Address Low

<付表 3>

MIDI PARAMETER CHANGE TABLE (SYSTEM)

Address	Size	Data Range(HEX)	Parameter Name	Description	Default(HEX)	Notes
00 00	00	1	00 - 7F	Master Volume	0 - 127	7F MIDI Master Volume
01	1	28 - 58	Master Note Shift	-24 - +24(semester)	40	
02	4	00 - 0F	Master Tune	-102.4 - +102.3[cent]	00 04 00 00 00	MIDI Master Tuning
				1st bit3-0	bit15-12	
				2nd bit3-0	bit11-8	
				3rd bit3-0	bit7-4	
				4th bit3-0	bit3-0	
06	1	00 - 01	Controller Reset	hold_reset	00	
07	1	35 - 4B	Master Transpose	-11 - +11(semester)	40	
08	1	3D - 43	Master Octave Shift	-3 - +3	40	
09	1	00 - 01	Local Switch	off.on	01	
0A	1	00 - 10.7F	Basic Receive Channel	1 - 16.omni.off	00	
0B	1	00 - 0F.7F	Keyboard Transmit Channel	1 - 16.off	00	
0C	1	00 - 01	MIDI Sync	int.MIDI	00	
0D	1	00 - 01	MIDI Control	off.on	00	
0E	1	00 - 01	Plug-in Board MIDI Sync/Control	off.on	00	
10	1		reserved		02	
11	1	00 - 03	BC Curve (for TG)	thru_soft_hard_wide	01	
12	1	00 - 04	Keyboard Velocity Curve	norm_soft_hard_wide_fixed	00	
13	1	01 - 7F	Keyboard Fixed Velocity	1 - 127	40	
14	1	00 - 01	Receive GM/XG On	off.on	01	
15	1	00 - 03	Receive Transmit Bank Select	off.all.part.perform	01	
16	1	00 - 01	Receive Program Change	off.on	00	
17	1	00 - 01	MIDI Control Mode	mode1_mode2	00	
18	1	00 - 07	Thru Port	1 - 8	00	
19	1		reserved		01	
1A	1	00 - 01	Effect Bypass Reverb	off.on	00	
1B	1	00 - 01	Effect Bypass Chorus	off.on	00	
1C	1	00 - 01	Effect Bypass Insertion	off.on	00	
1D	1		reserved		00	
1E	1	00 - 02	GM/XG Receive Mode	all-part_layer-part_all-off	02	
1F	1	00 - 03	Power on Mode	Performance_Voice(NT)_Voice(PRE1)_last	02	
20	1		reserved		00	
21	1		reserved		00	
22	1		reserved		00	
23	1		reserved		00	
24	1		reserved		00	
25	4		reserved		00	
29	1	00 - 5F	Scene Control Number	off.1 - 95	0E	
2A	1	00 - 33	Knob A Destination	off.1 - 51	01	
2B	1	00 - 33	Knob B Destination	off.1 - 51	07	
2C	1	00 - 33	Knob C Destination	off.1 - 51	0D	
2D	1	00 - 5F	Knob A Control Number	off.1 - 95	12	
2E	1	00 - 5F	Knob B Control Number	off.1 - 95	13	
2F	1	00 - 5F	Knob C Control Number	off.1 - 95	14	
30	1	00 - 01	FV Assign	volume_express	01	
31	1	00 - 64	FS Assign	off.1 - 95, Arp Sw, Arp Hold, SMF Play, PC Inc, PC Dec	58	
32	1	00 - 5F	ARP Switch Control Number	off.1 - 95	5A	
33	1	00 - 5F	ARP Hold Control Number	off.1 - 95	59	
34	1	00 - 01	ARP MIDI Out Switch	off.on	00	for Voice Mode
35	1	00 - 0F	ARP MIDI Out Channel	1 - 16	00	
36	1	00 - 5F	KN1 Control Number	off.1 - 95	10	
37	1	00 - 5F	KN2 Control Number	off.1 - 95	11	
38	1	00 - 5F	BC Control Number	off.1 - 95	02	
39	1	00 - 5F	FC Control Number	off.1 - 95	04	
3A	1	00 - 5F	RB Control Number	off.1 - 95	16	

TOTAL SIZE = 60 3C (HEX)

10	16	00 - 7F	Plug-in Native System Parameter	depends on Plug-in Board	depends on Plug-in Board
TOTAL SIZE = 32 20 (HEX)					

00 20	00	1	34 - 4C	EQ Gain1	-12 - +12[dB]	40	for Voice Mode
01	1	04 - 28	EQ Frequency1	32 - 2000[Hz]	0C		
02	1	01 - 78	EQ Q1	0.1 - 12.0	07		
03	1	00 - 01	EQ Shape1	shelv_peak	00		
04	1	34 - 4C	EQ Gain2	-12 - +12[dB]	40		
05	1	0E - 36	EQ Frequency2	100 - 10.0[KHz]	1C		
06	1	01 - 78	EQ Q2	0.1 - 12.0	07		
	1		NOT USED				
08	1	34 - 4C	EQ Gain3	-12 - +12[dB]	40		
09	1	0E - 36	EQ Frequency3	100 - 10.0[KHz]	22		
0A	1	01 - 78	EQ Q3	0.1 - 12.0	07		
	1		NOT USED				
0C	1	34 - 4C	EQ Gain4	-12 - +12[dB]	40		
0D	1	0E - 36	EQ Frequency4	100 - 10.0[KHz]	2E		
0E	1	01 - 78	EQ Q4	0.1 - 12.0	07		
	1		NOT USED				
10	1	34 - 4C	EQ Gain5	-12 - +12[dB]	40		
11	1	1C - 3A	EQ Frequency5	0.5 - 16.0[KHz]	34		
12	1	01 - 78	EQ Q5	0.1 - 12.0	07		
13	1	00 - 01	EQ Shape5	shelv_peak	00		

TOTAL SIZE = 20 14 (HEX)

MIDI PARAMETER CHANGE TABLE (BULK CONTROL)

Address	Size	Data Range(HEX)	Parameter Name	Description	Default(HEX)	Notes
0E 08	nn	0	-	Bulk Header	-	
09	nn	0	-	Normal Voice INT (nn = 0 - 127)	-	
0F	nn	0	-	Normal Voice EXT (nn = 0 - 127)	-	
19	nn	0	-	Normal Voice Edit Buffer (nn = 0)	-	
1F	nn	0	-	Plug-in Voice PLG (nn = 0 - 63)	-	
28	nn	0	-	Plug-in Voice Edit Buffer (nn = 0)	-	
28	nn	0	-	Drum Voice INT (nn = 0 - 1)	-	
29	nn	0	-	Drum Voice EXT (nn = 0 - 1)	-	
2E	nn	0	-	Drum Voice Edit Buffer (nn = 0)	-	
40	nn	0	-	Performance INT (nn = 0 - 127)	-	
41	nn	0	-	Performance EXT (nn = 0 - 63)	-	
4F	nn	0	-	Performance Edit Buffer (nn = 0)	-	
0F 08	nn	0	-	Bulk Footer	-	
09	nn	0	-	Normal Voice INT (nn = 0 - 127)	-	
0F	nn	0	-	Normal Voice EXT (nn = 0 - 127)	-	
19	nn	0	-	Normal Voice Edit Buffer (nn = 0)	-	
1F	nn	0	-	Plug-in Voice PLG (nn = 0 - 63)	-	
28	nn	0	-	Plug-in Voice Edit Buffer (nn = 0)	-	
28	nn	0	-	Drum Voice INT (nn = 0 - 1)	-	
29	nn	0	-	Drum Voice EXT (nn = 0 - 1)	-	
2E	nn	0	-	Drum Voice Edit Buffer (nn = 0)	-	
40	nn	0	-	Performance INT (nn = 0 - 127)	-	
41	nn	0	-	Performance EXT (nn = 0 - 63)	-	
4F	nn	0	-	Performance Edit Buffer (nn = 0)	-	

<付表 4 >

MIDI PARAMETER CHANGE TABLE (REMOTE SWITCH)

Address	Size	Data Range(HEX)	Parameter Name	Description	Default(HEX)	Notes
0A 00	10	1	00-01	PERFORM	off.on	
11	1	00-01	VOICE	off.on	--	
12	1	00-01	SEQ PLAY	off.on	--	
13	1	00-01	UTILITY	off.on	--	
14	1	00-01	GARD	off.on	--	
15	1	00-01	PLAY/STOP	off.on	--	
16	1	00-01	EDIT	off.on	--	
17	1	00-01	JOB	off.on	--	
18	1	00-01	SHIFT	off.on	--	
19	1	00-01	EF BYPASS	off.on	--	
1A	1	00-01	MASTER KEYBOARD	off.on	--	
1B	1	00-01	DEC/NO	off.on	--	
1C	1	00-01	INC/YES	off.on	--	
1D	1	00-01	EXIT	off.on	--	
1E	1	00-01	ENTER	off.on	--	
1F	1	00-01	STORE	off.on	--	
20	1	00-01	PRE1	off.on	--	
21	1	00-01	PRE2	off.on	--	
22	1	00-01	INT	off.on	--	
23	1	00-01	EXT	off.on	--	
25	1	00-01	PLG	off.on	--	
26	1	00-01	reserved	off.on	--	
27	1	00-01	QUICK ACCESS	off.on	--	
28	1	00-01	A	off.on	--	
29	1	00-01	B	off.on	--	
2A	1	00-01	C	off.on	--	
2B	1	00-01	D	off.on	--	
2C	1	00-01	E	off.on	--	
2D	1	00-01	F	off.on	--	
2E	1	00-01	G	off.on	--	
2F	1	00-01	H	off.on	--	
30	1	00-01	1	off.on	--	
31	1	00-01	2	off.on	--	
32	1	00-01	3	off.on	--	
33	1	00-01	4	off.on	--	
34	1	00-01	5	off.on	--	
35	1	00-01	6	off.on	--	
36	1	00-01	7	off.on	--	
37	1	00-01	8	off.on	--	
38	1	00-01	9	off.on	--	
39	1	00-01	10	off.on	--	
3A	1	00-01	11	off.on	--	
3B	1	00-01	12	off.on	--	
3C	1	00-01	13	off.on	--	
3D	1	00-01	14	off.on	--	
3E	1	00-01	15	off.on	--	
3F	1	00-01	16	off.on	--	

<付表 5 >

MIDI PARAMETER CHANGE TABLE (PERFORMANCE COMMON)

Address	Size	Data Range(HEX)	Parameter Name	Description	Default(HEX)	Notes
30 00	00	1	20-7E	Performance Name1	32_126(ASCII)	l
30 00	01	1	20-7E	Performance Name2	32_126(ASCII)	n
30 00	02	1	20-7E	Performance Name3	32_126(ASCII)	i
30 00	03	1	20-7E	Performance Name4	32_126(ASCII)	t
30 00	04	1	20-7E	Performance Name5	32_126(ASCII)	p
30 00	05	1	20-7E	Performance Name6	32_126(ASCII)	l
30 00	06	1	20-7E	Performance Name7	32_126(ASCII)	e
30 00	07	1	20-7E	Performance Name8	32_126(ASCII)	r
30 00	08	1	20-7E	Performance Name9	32_126(ASCII)	f
30 00	09	1	20-7E	Performance Name10	32_126(ASCII)	
30 00	0A	1	-	reserved		
30 00	0B	1	-	reserved		
30 00	0C	1	00-16	Performance Category	00_22(..._Sq)	00(-)
30 00	0E	1	00-02	Master Keyboard Mode	split_Azone.Layer	01
30 00	0F	1	00-7F	Master Keyboard Split Point	C-2_G8	3C
30 00	10	1	00-10	Layer Channel	1_16.BasicCh	10
30 00	11	1	00-01	ARP MIDI Out Switch	off.on	00
30 00	12	1	00-10	ARP MIDI Out Channel	1_16.khd-ct	00
30 00	13	1	00-7F	ARP Type	UpOct1 - GateCut3	00
30 00	14	1	00-01	ARP Switch	off.on	00
30 00	15	1	00-02	ARP Hold	sync.off.off.on	01
30 00	16	1	00-06	ARP Unit Multiply	50%,65%,75%,100%,133%,150%,200%	03
30 00	17	1	00-7F	ARP Note Limit Low	C-2_G8	7F
30 00	18	1	00-7F	ARP Note Limit High	C-2_G8	00
30 00	19	1	00-02	ARP Key Mode	sort.thru.direct	01
30 00	1A	1	00-01	ARP Vel Mode	original.thru	01
30 00	1B	2	0000-00C8	ARP Velocity Rate MSB	0_200%	64
30 00	1D	2	0000-00C8	ARP Velocity Rate LSB	0_200%	64
30 00	1E	2	0019-012C	ARP Gate Time Rate MSB	0_200%	64
30 00	1F	2	0019-012C	ARP Gate Time Rate LSB	25_300	00
30 00	21	1	01-7F	ARP Tempo MSB	LE3_C_R63	40
30 00	22	1	-	reserved		40
30 00	23	1	00-7F	QED Chorus Control	-64_+63	40
30 00	24	1	00-7F	QED Release Time	-64_+63	40
30 00	25	1	00-7F	QED Sustain Level	-64_+63	40
30 00	26	1	00-7F	QED Portamento Time	-64_+63	40
30 00	27	1	00-01	QED Portamento Switch	off.on	00
30 00	28	1	00-7F	QED KnobA	-64_+63	40
30 00	29	1	00-7F	QED KnobB	-64_+63	40
30 00	2A	1	00-7F	QED KnobC	-64_+63	40
30 00	2B	1	00-7F	QED/Scene 1 Knob1	-64_+63	40
30 00	2C	1	00-7F	QED/Scene 1 Knob2	-64_+63	40
30 00	2D	1	00-7F	QED/Scene 1 Cutoff Frequency	-64_+63	40
30 00	2E	1	00-7F	QED/Scene 1 Resonance	-64_+63	40
30 00	2F	1	00-7F	QED/Scene 1 Attack Time	-64_+63	40
30 00	30	1	00-7F	QED/Scene 1 Decay Time	-64_+63	40
30 00	31	1	00-7F	Scene 2 Knob1	-64_+63	40
30 00	32	1	00-7F	Scene 2 Knob2	-64_+63	40
30 00	33	1	00-7F	Scene 2 Cutoff Frequency	-64_+63	40
30 00	34	1	00-7F	Scene 2 Resonance	-64_+63	40
30 00	35	1	00-7F	Scene 2 Attack Time	-64_+63	40
30 00	36	1	00-7F	Scene 2 Decay Time	-64_+63	40
30 00	37	1	00-7F	Scene Control	0_127	00
30 00	38	1	00-7F	QED Volume	0_127	7F
30 00	39	1	00-7F	QED Reverb Send	0_127	7F
30 00	3A	1	00-7F	QED Chorus Send	0_127	7F
30 00	3B	1	00-5F	KN1 Control Number	off.1 - 95	10
30 00	3C	1	00-5F	KN2 Control Number	off.1 - 95	11
30 00	3D	1	00-5F	BC Control Number	off.1 - 95	02
30 00	3E	1	00-5F	FC Control Number	off.1 - 95	04
30 00	3F	1	00-5F	RB Control Number	off.1 - 95	16
30 00	40	1	00-01	RB Mode	hold.reset	00
30 00	41	1	00-7F	Insertion Effect Part for Normal	0 - 15; Part1...16 127: off	00
30 00	42	1	61-7F	Insertion Effect Part for Plug-in	97: PartPL 127: off	60
30 00	43	1	00-7F	Insertion Plug-in Part	0 - 15; Part1...16 127: off	7F

TOTAL SIZE = 68 44 (HEX)

Address	Size	Data Range(HEX)	Parameter Name	Description	Default(HEX)	Notes
30 01	00	2	00-7F	Reverb Type MSB	Effect Parameter List 1 参照	Depends On Effect Type
30 01	02	2	00-7F	Reverb Type LSB		
30 01	04	2	00-7F	Reverb Parameter 1 MSB	#	#
30 01	06	2	00-7F	Reverb Parameter 1 LSB		
30 01	08	2	00-7F	Reverb Parameter 2 MSB	#	#
30 01	0A	2	00-7F	Reverb Parameter 2 LSB		
30 01	0C	2	00-7F	Reverb Parameter 3 MSB	#	#
30 01	0E	2	00-7F	Reverb Parameter 3 LSB		
30 01	10	2	00-7F	Reverb Parameter 4 MSB	#	#
30 01	12	2	00-7F	Reverb Parameter 4 LSB		
30 01	14	2	00-7F	Reverb Parameter 5 MSB	#	#
30 01	16	2	00-7F	Reverb Parameter 5 LSB		
30 01	18	2	00-7F	Reverb Parameter 6 MSB	#	#
30 01	1A	2	00-7F	Reverb Parameter 6 LSB		
30 01	1C	2	00-7F	Reverb Parameter 7 MSB	#	#
30 01	1E	2	00-7F	Reverb Parameter 7 LSB		
30 01	20	2	00-7F	Reverb Parameter 8 MSB	#	#
30 01	22	2	00-7F	Reverb Parameter 8 LSB		
30 01	24	2	00-7F	Reverb Parameter 9 MSB	#	#
30 01	26	2	00-7F	Reverb Parameter 9 LSB		
30 01	28	2	00-7F	Reverb Parameter 10 MSB	#	#
30 01	2A	2	00-7F	Reverb Parameter 10 LSB		
30 01	16	1	00-7F	Reverb Return	--dB...0dB...+6dB(0...96...127)	7F
30 01	17	1	01-7F	Reverb Pan	LE3_C_R63	40

TOTAL SIZE = 24 16 (HEX)

Address	Size	Data Range(HEX)	Parameter Name	Description	Default(HEX)	Notes
30 02 00	2	00 - 7F	Chorus Type MSB	Effect Parameter List 番号		Depends On Effect Type
		00 - 7F	Chorus Type LSB			
30 02 02	2	00 - 7F	Chorus Parameter 1 MSB	"	"	
		00 - 7F	Chorus Parameter 1 LSB			
30 02 04	2	00 - 7F	Chorus Parameter 2 MSB	"	"	
		00 - 7F	Chorus Parameter 2 LSB			
30 02 06	2	00 - 7F	Chorus Parameter 3 MSB	"	"	
		00 - 7F	Chorus Parameter 3 LSB			
30 02 08	2	00 - 7F	Chorus Parameter 4 MSB	"	"	
		00 - 7F	Chorus Parameter 4 LSB			
30 02 0A	2	00 - 7F	Chorus Parameter 5 MSB	"	"	
		00 - 7F	Chorus Parameter 5 LSB			
30 02 0C	2	00 - 7F	Chorus Parameter 6 MSB	"	"	
		00 - 7F	Chorus Parameter 6 LSB			
30 02 0E	2	00 - 7F	Chorus Parameter 7 MSB	"	"	
		00 - 7F	Chorus Parameter 7 LSB			
30 02 10	2	00 - 7F	Chorus Parameter 8 MSB	"	"	
		00 - 7F	Chorus Parameter 8 LSB			
30 02 12	2	00 - 7F	Chorus Parameter 9 MSB	"	"	
		00 - 7F	Chorus Parameter 9 LSB			
30 02 14	2	00 - 7F	Chorus Parameter 10 MSB	"	"	
		00 - 7F	Chorus Parameter 10 LSB			
30 02 16	1	00 - 7F	Chorus Return	--dB_0dB...+6dB(0..96..127)	7F	
30 02 17	1	01 - 7F	Chorus Pan	L63..C..R63	40	
30 02 18	1	00 - 7F	Send Chorus To Reverb	--dB_0dB(0..127)	00	

TOTAL SIZE = 25 19 (HEX)

30 05 01	2	00	Controller Set1 Destination MSB	0 - 29	00	
		00 - 1D	Controller Set1 Destination LSB			
30 05 03	1	00 - 7F	Controller Set1 Depth	-64 +63	40	
30 05 04	1		reserved		00	
30 05 05	1	00 - 09	Controller Set2 Source	PB, MW1, ..., AT, FC, FS, RB, BC, KN1, KN2	00	
30 05 06	2	00	Controller Set2 Destination MSB	0 - 29	00	
		00 - 1D	Controller Set2 Destination LSB			
30 05 08	1	00 - 7F	Controller Set2 Depth	-64 +63	40	
30 05 09	1		reserved		00	

TOTAL SIZE = 10 0A (HEX)

30 10 00	1	34 - 4C	EQ Gain1	-12 - +12[dB]	40	
30 10 01	1	04 - 28	EQ Frequency1	32 - 2000[Hz]	0C	
30 10 02	1	01 - 78	EQ Q1	0.1 - 12.0	07	
30 10 03	1	00 - 01	EQ Shape1	shelv.peak	00	
30 10 04	1	34 - 4C	EQ Gain2	-12 - +12[dB]	40	
30 10 05	1	0E - 3E	EQ Frequency2	100 - 10.0[Hz]	1C	
30 10 06	1	01 - 78	EQ Q2	0.1 - 12.0	07	
	1		Not Used			
30 10 08	1	34 - 4C	EQ Gain3	-12 - +12[dB]	40	
30 10 09	1	0E - 3E	EQ Frequency3	100 - 10.0[Hz]	22	
30 10 0A	1	01 - 78	EQ Q3	0.1 - 12.0	07	
	1		Not Used			
30 10 0C	1	34 - 4C	EQ Gain4	-12 - +12[dB]	40	
30 10 0D	1	0E - 3E	EQ Frequency4	100 - 10.0[Hz]	2E	
30 10 0E	1	01 - 78	EQ Q4	0.1 - 12.0	07	
	1		Not Used			
30 10 10	1	34 - 4C	EQ Gain5	-12 - +12[dB]	40	
30 10 11	1	1C - 3A	EQ Frequency5	0.5 - 16.0[Hz]	34	
30 10 12	1	01 - 78	EQ Q5	0.1 - 12.0	07	
30 10 13	1	00 - 01	EQ Shape5	shelv.peak	00	

TOTAL SIZE = 20 14 (HEX)

30 20 00	16	00 - 7F	Plug-in Board Native System Parameter	(for InsEF Plug-in)		depends on Plug-in Board
30 20 10	48	00 - 7F	Plug-in Board Native Parameter	(for InsEF Plug-in)		depends on Plug-in Board
30 20 40	3	00 - 7F	Plug-in Board Type MSB	(for InsEF Plug-in)		depends on Plug-in Board
		00 - 7F	Plug-in Board Type LSB			
		00 - 7F	Plug-in Board Version Number			
43	1	00 - 7F	reserved			

TOTAL SIZE = 68 44 (HEX)

<付表 6 >
MIDI PARAMETER CHANGE TABLE (PERFORMANCE PART)

Address	Size	Data Range(HEX)	Parameter Name	Description	Default(HEX)	Notes
31 pp 00	1	00 - 7F	Bank Select MSB	0 - 127	00	
31 pp 01	1	00 - 7F	Bank Select LSB	0 - 127	00	
31 pp 02	1	00 - 7F	Program Number	1 - 128	00	
31 pp 03	1	00 - 0F, 7F	Receive Channel	1, 16, off(7F)		Part No.
31 pp 04	1	00 - 01	Part Mode	mono.poly	01	Part1-16, PL
31 pp 05	1	01 - 7F	Velocity Limit Low	1 - 127	01	Part1-16, PL
31 pp 06	1	01 - 7F	Velocity Limit High	1 - 127	7F	Part1-16, PL
31 pp 07	1	00 - 7F	Note Limit Low	C-2 - G8	00	Part1-16, PL
31 pp 08	1	00 - 7F	Note Limit High	C-2 - G8	7F	Part1-16, PL
31 pp 09	1	10 - 58	Pitch Bend Range Upper	-48 +24	40	Part1-16, PL
31 pp 0A	1	10 - 58	Pitch Bend Range Lower	-48 +24	40	Part1-16
31 pp 0B	1	00 - 7F	Velocity Sense Depth	0 - 127	40	Part1-16, PL
31 pp 0C	1	00 - 7F	Velocity Sense Offset	0 - 127	40	Part1-16, PL
31 pp 0D	1	00 - 7F	Volume	0 - 127	64	
31 pp 0E	1	01 - 7F	Pan	L63 - C - R63	40	
31 pp 0F	1		reserved		40	
31 pp 10	2	00 - 0F	Detune MSB	-12.8 - +12.7[Hz]		
		00 - 0F	Detune LSB	1st bit:3-0 bit7-4 2nd bit:3-0 bit3-0	08 00 (80)	Part1-16, PL
31 pp 12	1	00 - 7F	Reverb Send	0 - 127	28	
31 pp 13	1	00 - 7F	Chorus Send	0 - 127	00	
31 pp 14	1		reserved		00	
31 pp 15	1	28 - 58	Note Shift	-24 +24[semitones]	40	Part1-16, PL
31 pp 16	1	00 - 7F	Filter Cutoff Frequency	-64 +63	40	Part1-16, PL
31 pp 17	1	00 - 7F	Filter Resonance/Width	-64 +63	40	Part1-16, PL
31 pp 18	1		reserved		40	
31 pp 19	1	00 - 01	Portamento Switch	off.on	00	Part1-16, PL
31 pp 1A	1	00 - 7F	Portamento Time	0 - 127	40	Part1-16, PL
31 pp 1B	1	00 - 01	Portamento Mode	fingered.fulltime	00	Part1-16
31 pp 1C	1		reserved		00	
31 pp 1D	1	00 - 7F	Layer Sw	bit0: Layer Sw off.on bit1: Arpeggio Sw off.on bit2: off.on Control Change bit3: off.on Bank Select bit4: off.on Program Change bit5: off.on AT bit6: off.on PB	7C	Part1-16, Otheroff Part1-16, PL
31 pp 1E	1	00 - 7F	Receive Volume/Expression Receive Pan	bit0: off.on Volume/Expression bit1: off.on Pan bit2: reserved bit3: off.on Sustain/Sostenute bit4: reserved bit5: off.on MW bit6: reserved	7F	
31 pp 1F	1	00 - 7F	Receive FC Receive FS Receive RB Receive BC Receive Knob1 Receive Knob2	bit0: off.on FC bit1: off.on FS bit2: off.on RB bit3: off.on BC bit4: off.on KN1 bit5: off.on KN2 bit6: reserved	7F	
31 pp 20	1	00 - 7F	AEG Decay2 Level (EG Sustain Level)	-64 +63	40	Part1-16
31 pp 21	1	00 - 7F	AEG Attack Time (EG Attack Time)	-64 +63	40	Part1-16, PL
31 pp 22	1		reserved		40	
31 pp 23	1	00 - 7F	AEG Decay2 Time (EG Decay Time)	-64 +63	40	Part1-16, PL
31 pp 24	1	00 - 7F	AEG Release Time (EG Release Time)	-64 +63	40	Part1-16, PL

TOTAL SIZE = 37 25 (HEX)

pp = part number
00 - 0F Part 1 - 16
61 Part Plug-in

<付表 7 >
MIDI PARAMETER CHANGE TABLE (MASTER KEYBOARD ZONE)

Address	Size	Data Range(HEX)	Parameter Name	Description	Default(HEX)	Notes
32 m 00	1	00 - 3F	Transmit Channel, MIDI/TG Switch	bit0-3: Ch1..16 bit4: MIDI off.on bit5: TG off.on		Zone1-30, Other:00
32 m 01	1	3D - 43	Transpose (Octave)	-3, +3	40	
32 m 02	1	35 - 4B	Transpose (Semitone)	-11, +11[semitones]	40	
32 m 03	1	00 - 7F	Note Limit Low	C-2 - G8	00	
32 m 04	1	00 - 7F	Note Limit High	C-2 - G8	7F	
32 m 05	1		reserved		01	
32 m 06	1		reserved		7F	
32 m 07	1	00 - 7F	MIDI Volume	0 - 127	64	
32 m 08	1	00 - 7F	MIDI Pan	0 - 127	40	
32 m 09	1	00 - 7F	MIDI Bank MSB	0 - 127	00	
32 m 0A	1	00 - 7F	MIDI Bank LSB	0 - 127	00	
32 m 0B	1	00 - 7F	MIDI Program Number	1 - 128	00	
32 m 0C	1	00 - 7F	Transmit Volume/FV Transmit Pan Transmit Sustain Transmit Bank Select Transmit Program Change Transmit AT Transmit PB	bit0: off.on FV (Volume/Expression) bit1: off.on Pan bit2: off.on Sustain bit3: off.on Bank Select bit4: off.on Program Change bit5: off.on AT bit6: off.on PB	7F	
32 m 0D	1	00 - 7F	Transmit FC Transmit FS Transmit RB Transmit BC Transmit MW Transmit Assignable Knob (A/B/C) Transmit Assignable Knob (1/2)	bit0: off.on FC bit1: off.on FS bit2: off.on RB bit3: off.on BC bit4: off.on MW bit5: off.on Assignable Knob A,B,C bit6: off.on Assignable Knob 1,2	7F	
32 m 0E	1	00 - 5F	Control Slider Control Number	off.1 - 95	07	
32 m 0F	1		reserved		00	

TOTAL SIZE = 16 10 (HEX)

m = zone number 00 - 03

<付表 8 >

MIDI PARAMETER CHANGE TABLE (NORMAL VOICE COMMON)

Address	Size	Data Range(HEX)	Parameter Name	Description	Default(HEX)	Notes
40 70 00	1	20 - 7E	Voice Name1	32_126(ASCII)	i	
40 70 01	1	20 - 7E	Voice Name2	32_126(ASCII)	n	
40 70 02	1	20 - 7E	Voice Name3	32_126(ASCII)	i	
40 70 03	1	20 - 7E	Voice Name4	32_126(ASCII)	t	
40 70 04	1	20 - 7E	Voice Name5	32_126(ASCII)		
40 70 05	1	20 - 7E	Voice Name6	32_126(ASCII)	v	
40 70 06	1	20 - 7E	Voice Name7	32_126(ASCII)	p	
40 70 07	1	20 - 7E	Voice Name8	32_126(ASCII)	j	
40 70 08	1	20 - 7E	Voice Name9	32_126(ASCII)	c	
40 70 09	1	20 - 7E	Voice Name10	32_126(ASCII)	e	
40 70 0A	1		reserved			
40 70 0B	1		reserved			
40 70 0C	1	00 - 16	Voice Category	00_22(-, Sa)	00(-)	
40 70 0D	1		reserved			
40 70 0E	1		reserved			
40 70 0F	1		reserved			
40 70 10	1		reserved			
40 70 11	1		reserved			
40 70 12	1		reserved			
40 70 13	1	00 - 7F	ARP Type	UprOct1 - GateCut3	00	
40 70 14	1	00 - 01	ARP Switch	off.on		
40 70 15	1	00 - 02	ARP Hold	sync-off.off.on	01	
40 70 16	1	00 - 06	ARP Unit Multiply	50%,66%,75%,100%,133%,150%,200%	03	
40 70 17	1	00 - 7F	ARP Note Limit Low	C-2_G8	00	
40 70 18	1	00 - 7F	ARP Note Limit High	C-2_G8	7F	
40 70 19	1	00 - 02	ARP Key Mode	sort.thru.direct	01	
40 70 1A	1	00 - 01	ARP Vel Mode	original.thru	01	
40 70 1B	2	0000 - 00C8	ARP Velocity Rate MSB ARP Velocity Rate LSB	0_200%	64	
40 70 1D	2	0000 - 00C8	ARP Gate Time Rate MSB ARP Gate Time Rate LSB	0_200%	64	
40 70 1F	2	0019 - 012C	ARP Tempo MSB ARP Tempo LSB	25_300	8A	
40 70 21	1	01 - 7F	QED Pan	L63_C_R63	40	
40 70 22	1		reserved			
40 70 23	1	00 - 7F	QED Chorus Control	-64_+63	40	
40 70 24	1	00 - 7F	QED Release Time	-64_+63	40	
40 70 25	1	00 - 7F	QED Sustain Level	-64_+63	40	
40 70 26	1		reserved			
40 70 27	1		reserved			
40 70 28	1	00 - 7F	QED KnobA	-64_+63	40	
40 70 29	1	00 - 7F	QED KnobB	-64_+63	40	
40 70 2A	1	00 - 7F	QED KnobC	-64_+63	40	
40 70 2B	1	00 - 7F	QED/Scene 1 Knob1	-64_+63	40	
40 70 2C	1	00 - 7F	QED/Scene 1 Knob2	-64_+63	40	
40 70 2D	1	00 - 7F	QED/Scene 1 Cutoff Frequency	-64_+63	40	
40 70 2E	1	00 - 7F	QED/Scene 1 Resonance	-64_+63	40	
40 70 2F	1	00 - 7F	QED/Scene 1 Attack Time	-64_+63	40	
40 70 30	1	00 - 7F	QED/Scene 1 Decay Time	-64_+63	40	
40 70 31	1	00 - 7F	Scene 2 Knob1	-64_+63	40	
40 70 32	1	00 - 7F	Scene 2 Knob2	-64_+63	40	
40 70 33	1	00 - 7F	Scene 2 Cutoff Frequency	-64_+63	40	
40 70 34	1	00 - 7F	Scene 2 Resonance	-64_+63	40	
40 70 35	1	00 - 7F	Scene 2 Attack Time	-64_+63	40	
40 70 36	1	00 - 7F	Scene 2 Decay Time	-64_+63	40	
40 70 37	1	00 - 7F	Scene Control	0_127	00	

TOTAL SIZE = 56 38 (HEX)

40 00 00	1	00 - 7F	Volume	0 - 127	64	
40 00 01	1	00 - 0F	Element Switch	BIT3:EL4, BIT2:EL3, BIT1:EL2, BIT0:EL1	01	
40 00 02	1	00 - 01	Same Note Number Key On Assign	single_multi	00	
40 00 03	1	00 - 01	Monopoly Mode	mono.poly	01	
40 00 04	1	00 - 1F	Misc Tuning	Equal - Indian	00	
40 00 05	1	10 - 58	Pitch Bend Range Upper	-48 +24[semitones]	42	
40 00 06	1	10 - 58	Pitch Bend Range Lower	-48 +24[semitones]	3E	
40 00 07	1	00 - 01	Portamento Mode	fingered.fulltime	00	
40 00 08	1	00 - 01	Portamento Switch	off.on	00	
40 00 09	1	00 - 7F	Portamento Time	0 - 127	00	
40 00 0A	1	00 - 02	Insertion Connect Type	1/2(Parallel), 1->2, 2->1	00	
40 00 0B	1	00 - 7F	Reverb Send	--dB_0dB	00	
40 00 0C	1	00 - 7F	Chorus Send	--dB_0dB	00	

TOTAL SIZE = 13 0D (HEX)

40 01 00	2	00 - 7F	Reverb Type MSB	Effect Parameter List 参照	0100	
40 01 01	2	00 - 7F	Reverb Type LSB			
40 01 02	2	00 - 7F	Reverb Parameter 1 MSB	#	Depends On Effect Type	
40 01 03	2	00 - 7F	Reverb Parameter 1 LSB	#		
40 01 04	2	00 - 7F	Reverb Parameter 2 MSB	#	#	
40 01 05	2	00 - 7F	Reverb Parameter 2 LSB	#	#	
40 01 06	2	00 - 7F	Reverb Parameter 3 MSB	#	#	
40 01 07	2	00 - 7F	Reverb Parameter 3 LSB	#	#	
40 01 08	2	00 - 7F	Reverb Parameter 4 MSB	#	#	
40 01 09	2	00 - 7F	Reverb Parameter 4 LSB	#	#	
40 01 0A	2	00 - 7F	Reverb Parameter 5 MSB	#	#	
40 01 0B	2	00 - 7F	Reverb Parameter 5 LSB	#	#	
40 01 0C	2	00 - 7F	Reverb Parameter 6 MSB	#	#	
40 01 0D	2	00 - 7F	Reverb Parameter 6 LSB	#	#	
40 01 0E	2	00 - 7F	Reverb Parameter 7 MSB	#	#	
40 01 0F	2	00 - 7F	Reverb Parameter 7 LSB	#	#	
40 01 10	2	00 - 7F	Reverb Parameter 8 MSB	#	#	
40 01 11	2	00 - 7F	Reverb Parameter 8 LSB	#	#	
40 01 12	2	00 - 7F	Reverb Parameter 9 MSB	#	#	
40 01 13	2	00 - 7F	Reverb Parameter 9 LSB	#	#	
40 01 14	2	00 - 7F	Reverb Parameter 10 MSB	#	#	
40 01 15	2	00 - 7F	Reverb Parameter 10 LSB	#	#	
40 01 16	1	00 - 7F	Reverb Return	--dB_0dB_+6dB(0_96...127)	40	
40 01 17	1	01 - 7F	Reverb Pan	L63_C_R63	40	

TOTAL SIZE = 24 18 (HEX)

40 02 00	2	00 - 7F	Chorus Type MSB	Effect Parameter List 参照	0500	
40 02 01	2	00 - 7F	Chorus Type LSB			
40 02 02	2	00 - 7F	Chorus Parameter 1 MSB	#	Depends On Effect Type	
40 02 03	2	00 - 7F	Chorus Parameter 1 LSB	#	#	
40 02 04	2	00 - 7F	Chorus Parameter 2 MSB	#	#	
40 02 05	2	00 - 7F	Chorus Parameter 2 LSB	#	#	
40 02 06	2	00 - 7F	Chorus Parameter 3 MSB	#	#	
40 02 07	2	00 - 7F	Chorus Parameter 3 LSB	#	#	
40 02 08	2	00 - 7F	Chorus Parameter 4 MSB	#	#	
40 02 09	2	00 - 7F	Chorus Parameter 4 LSB	#	#	
40 02 0A	2	00 - 7F	Chorus Parameter 5 MSB	#	#	
40 02 0B	2	00 - 7F	Chorus Parameter 5 LSB	#	#	
40 02 0C	2	00 - 7F	Chorus Parameter 6 MSB	#	#	
40 02 0D	2	00 - 7F	Chorus Parameter 6 LSB	#	#	
40 02 0E	2	00 - 7F	Chorus Parameter 7 MSB	#	#	
40 02 0F	2	00 - 7F	Chorus Parameter 7 LSB	#	#	
40 02 10	2	00 - 7F	Chorus Parameter 8 MSB	#	#	
40 02 11	2	00 - 7F	Chorus Parameter 8 LSB	#	#	
40 02 12	2	00 - 7F	Chorus Parameter 9 MSB	#	#	
40 02 13	2	00 - 7F	Chorus Parameter 9 LSB	#	#	
40 02 14	2	00 - 7F	Chorus Parameter 10 MSB	#	#	
40 02 15	2	00 - 7F	Chorus Parameter 10 LSB	#	#	
40 02 16	1	00 - 7F	Chorus Return	--dB_0dB_+6dB(0_96...127)	40	
40 02 17	1	01 - 7F	Chorus Pan	L63_C_R63	40	
40 02 18	1	00 - 7F	Send Chorus To Reverb	--dB_0dB(0_127)	00	

TOTAL SIZE = 25 19 (HEX)

Address	Size	Data Range(HEX)	Parameter Name	Description	Default(HEX)	Notes
40 03 00	2	00 - 7F	Insertion-1 Type MSB	Effect Parameter List 参照	0000	
40 03 01	2	00 - 7F	Insertion-1 Type LSB			
40 03 02	2	00 - 7F	Insertion-1 Parameter1 MSB	#	Depends On Effect Type	
40 03 03	2	00 - 7F	Insertion-1 Parameter1 LSB	#	#	
40 03 04	2	00 - 7F	Insertion-1 Parameter2 MSB	#	#	
40 03 05	2	00 - 7F	Insertion-1 Parameter2 LSB	#	#	
40 03 06	2	00 - 7F	Insertion-1 Parameter3 MSB	#	#	
40 03 07	2	00 - 7F	Insertion-1 Parameter3 LSB	#	#	
40 03 08	2	00 - 7F	Insertion-1 Parameter4 MSB	#	#	
40 03 09	2	00 - 7F	Insertion-1 Parameter4 LSB	#	#	
40 03 0A	2	00 - 7F	Insertion-1 Parameter5 MSB	#	#	
40 03 0B	2	00 - 7F	Insertion-1 Parameter5 LSB	#	#	
40 03 0C	2	00 - 7F	Insertion-1 Parameter6 MSB	#	#	
40 03 0D	2	00 - 7F	Insertion-1 Parameter6 LSB	#	#	
40 03 0E	2	00 - 7F	Insertion-1 Parameter7 MSB	#	#	
40 03 0F	2	00 - 7F	Insertion-1 Parameter7 LSB	#	#	
40 03 10	2	00 - 7F	Insertion-1 Parameter8 MSB	#	#	
40 03 11	2	00 - 7F	Insertion-1 Parameter8 LSB	#	#	
40 03 12	2	00 - 7F	Insertion-1 Parameter9 MSB	#	#	
40 03 13	2	00 - 7F	Insertion-1 Parameter9 LSB	#	#	
40 03 14	2	00 - 7F	Insertion-1 Parameter10 MSB	#	#	
40 03 15	2	00 - 7F	Insertion-1 Parameter10 LSB	#	#	

TOTAL SIZE = 22 16 (HEX)

40 04 00	2	00 - 7F	Insertion-2 Type MSB	Effect Parameter List 参照	0000	
40 04 01	2	00 - 7F	Insertion-2 Type LSB			
40 04 02	2	00 - 7F	Insertion-2 Parameter 1 MSB	#	Depends On Effect Type	
40 04 03	2	00 - 7F	Insertion-2 Parameter 1 LSB	#	#	
40 04 04	2	00 - 7F	Insertion-2 Parameter 2 MSB	#	#	
40 04 05	2	00 - 7F	Insertion-2 Parameter 2 LSB	#	#	
40 04 06	2	00 - 7F	Insertion-2 Parameter 3 MSB	#	#	
40 04 07	2	00 - 7F	Insertion-2 Parameter 3 LSB	#	#	
40 04 08	2	00 - 7F	Insertion-2 Parameter 4 MSB	#	#	
40 04 09	2	00 - 7F	Insertion-2 Parameter 4 LSB	#	#	
40 04 0A	2	00 - 7F	Insertion-2 Parameter 5 MSB	#	#	
40 04 0B	2	00 - 7F	Insertion-2 Parameter 5 LSB	#	#	
40 04 0C	2	00 - 7F	Insertion-2 Parameter 6 MSB	#	#	
40 04 0D	2	00 - 7F	Insertion-2 Parameter 6 LSB	#	#	
40 04 0E	2	00 - 7F	Insertion-2 Parameter 7 MSB	#	#	
40 04 0F	2	00 - 7F	Insertion-2 Parameter 7 LSB	#	#	
40 04 10	2	00 - 7F	Insertion-2 Parameter 8 MSB	#	#	
40 04 11	2	00 - 7F	Insertion-2 Parameter 8 LSB	#	#	
40 04 12	2	00 - 7F	Insertion-2 Parameter 9 MSB	#	#	
40 04 13	2	00 - 7F	Insertion-2 Parameter 9 LSB	#	#	
40 04 14	2	00 - 7F	Insertion-2 Parameter 10 MSB	#	#	
40 04 15	2	00 - 7F	Insertion-2 Parameter 10 LSB	#	#	
40 04 16	2	00 - 7F	Insertion-2 Parameter 11 MSB	#	#	
40 04 17	2	00 - 7F	Insertion-2 Parameter 11 LSB	#	#	
40 04 18	2	00 - 7F	Insertion-2 Parameter 12 MSB	#	#	
40 04 19	2	00 - 7F	Insertion-2 Parameter 12 LSB	#	#	
40 04 1A	2	00 - 7F	Insertion-2 Parameter 13 MSB	#	#	
40 04 1B	2	00 - 7F	Insertion-2 Parameter 13 LSB	#	#	
40 04 1C	2	00 - 7F	Insertion-2 Parameter 14 MSB	#	#	
40 04 1D	2	00 - 7F	Insertion-2 Parameter 14 LSB	#	#	
40 04 1E	2	00 - 7F	Insertion-2 Parameter 15 MSB	#	#	
40 04 1F	2	00 - 7F	Insertion-2 Parameter 15 LSB	#	#	
40 04 20	2	00 - 7F	Insertion-2 Parameter 16 MSB	#	#	
40 04 21	2	00 - 7F	Insertion-2 Parameter 16 LSB	#	#	

TOTAL SIZE = 34 22 (HEX)

40 05 00	1	00 - 09	Controller Set1 Source	PB, MW, ---, AT, FC, FS, RB, BC, KN1, KN2	00	
40 05 01	2	00	Controller Set1 Destination MSB	0 - 61	00	
40 05 02	2	00	Controller Set1 Destination LSB			
40 05 03	1	00 - 7F	Controller Set1 Depth	-64 +63	40	
40 05 04	1	00 - 0F	Controller Set1 Element Switch	BIT0:EL1, BIT1:EL2, BIT2:EL3, BIT3:EL4	00	
40 05 05	1	00 - 09	Controller Set2 Source	PB, MW, ---, AT, FC, FS, RB, BC, KN1, KN2	00	
40 05 06	2	00	Controller Set2 Destination MSB	0 - 61	00	
40 05 07	2	00	Controller Set2 Destination LSB			
40 05 08	1	00 - 7F	Controller Set2 Depth	-64 +63	40	
40 05 09	1	00 - 0F	Controller Set2 Element Switch	BIT0:EL1, BIT1:EL2, BIT2:EL3, BIT3:EL4	00	
40 05 0A	1	00 - 09	Controller Set3 Source	PB, MW, ---, AT, FC, FS, RB, BC, KN1, KN2	00	
40 05 0B	2	00	Controller Set3 Destination MSB	0 - 61	00	
40 05 0C	2	00	Controller Set3 Destination LSB			
40 05 0D	1	00 - 7F	Controller Set3 Depth	-64 +63	40	
40 05 0E	1	00 - 0F	Controller Set			

Address	Size	Data Range(HEX)	Parameter Name	Description	Default(HEX)	Notes
41 ee 20	1	00 - 7F	Element Level	0 - 127	64	
41 ee 21	1	00 - 7F	Level Velocity Sensitivity	-64 - +63	40	
41 ee 22	1	00 - 7F	reserved		00	
41 ee 23	1	00 - 7F	AEG Attack Time	0 - 127	00	
41 ee 24	1	00 - 7F	AEG Decay1 Time	0 - 127	00	
41 ee 25	1	00 - 7F	AEG Decay2 Time	0 - 127	00	
41 ee 26	1	00 - 7F	AEG Release Time	0 - 127	40	
41 ee 27	1	00 - 7F	AEG Init Level	0 - 127	00	
41 ee 28	1	00	reserved			
41 ee 29	1	00 - 7F	AEG Decay1 Level	0 - 127	7F	
41 ee 2A	1	00 - 7F	AEG Sustain Level	0 - 127	7F	
41 ee 2B	1	00 - 7F	reserved		00	
41 ee 2C	1	00 - 01	AEG Time Velocity Segment	attack_all	01	
41 ee 2D	1	00 - 7F	AEG Time Velocity Sensitivity	-64 - +63	40	
41 ee 2E	1	00 - 7F	Level Key Follow Sensitivity	-200% - +200%	40	
41 ee 2F	1	00 - 7C	Level Scaling Break Point 1	C - 2 - E8	24	BP1-BP2-BP3-BP4
41 ee 30	1	01 - 7D	Level Scaling Break Point 2	C#-2 - F8	30	BP1-BP2-BP3-BP4
41 ee 31	1	02 - 7E	Level Scaling Break Point 3	D - 2 - F#8	3C	BP1-BP2-BP3-BP4
41 ee 32	1	03 - 7F	Level Scaling Break Point 4	D#-2 - G8	48	BP1-BP2-BP3-BP4
41 ee 33	2	00 - 01	Level Scaling Offset 1	-128 - +127	01 00	
41 ee 34	2	00 - 7F	reserved			
41 ee 35	2	00 - 01	Level Scaling Offset 2	-128 - +127	01 00	
41 ee 36	2	00 - 7F	reserved			
41 ee 37	2	00 - 01	Level Scaling Offset 3	-128 - +127	01 00	
41 ee 38	2	00 - 7F	reserved			
41 ee 39	2	00 - 01	Level Scaling Offset 4	-128 - +127	01 00	
41 ee 3A	2	00 - 7F	reserved			
41 ee 3B	1	00 - 7F	AEG Time Key Follow Sensitivity	-64 - +63	40	
41 ee 3C	1	00 - 7F	AEG Time Key Follow Center Note	C-2 - G8	3C	

TOTAL SIZE = 29 1D (HEX)

42 ee 00	1	10 - 70	Coarse Tune	-48 - +48	40	
42 ee 01	1	00 - 7F	Fine Tune	-64 - +63	40	
42 ee 02	1	00	reserved		00	
42 ee 03	1	00 - 7F	Random Pitch Depth	0 - 127	00	
42 ee 04	1	00 - 7F	PEG Hold Time	0 - 127	00	
42 ee 05	1	00 - 7F	PEG Attack Time	0 - 127	00	
42 ee 06	1	00 - 7F	PEG Decay1 Time	0 - 127	00	
42 ee 07	1	00 - 7F	PEG Decay2 Time	0 - 127	00	
42 ee 08	1	00 - 7F	PEG Release Time	0 - 127	00	
42 ee 09	2	00 - 01	PEG Hold Level	-128 - +127 (-4800 + 4800[cent])	01 00	
42 ee 0A	2	00 - 01	PEG Attack Level	-128 - +127 (-4800 + 4800[cent])	01 00	
42 ee 0B	2	00 - 7F	reserved			
42 ee 0C	2	00 - 01	PEG Decay1 Level	-128 - +127 (-4800 + 4800[cent])	01 00	
42 ee 0D	2	00 - 7F	reserved			
42 ee 0E	2	00 - 01	PEG Sustain Level	-128 - +127 (-4800 + 4800[cent])	01 00	
42 ee 0F	2	00 - 7F	reserved			
42 ee 10	2	00 - 01	PEG Release Level	-128 - +127 (-4800 + 4800[cent])	01 00	
42 ee 11	2	00 - 7F	reserved			
42 ee 12	1	00 - 7F	PEG Depth	-64 - +63	40	
42 ee 13	1	00 - 7F	PEG Time Velocity Segment	attack_all	01	
42 ee 14	1	00 - 01	PEG Time Velocity Segment	attack_all	01	
42 ee 15	1	00 - 7F	PEG Time Velocity Sensitivity	-64 - +63	40	
42 ee 16	1	00 - 7F	PEG Level Velocity Sensitivity	-64 - +63	40	
42 ee 17	1	00 - 7F	Pitch Key Follow Sensitivity	-200% - +200%	60	
42 ee 18	1	00 - 7F	Pitch Key Follow Center Note	C-2 - G8	3C	
42 ee 19	1	00 - 7F	PEG Time Key Follow Sensitivity	-64 - +63	40	
42 ee 1A	1	00 - 7F	PEG Time Key Follow Center Note	C-2 - G8	3C	

TOTAL SIZE = 27 1B (HEX)

43 ee 00	1	00 - 0C	Filter Type	LPF12-HPF1,LPF24D,LPF24A,LPF18,LPF18s,LPF6-HPF,HPF24D,HPF12,BPF6,BPF12D,BPF6,BEF6,THRU	02	
43 ee 01	2	00 - 01	Filter Cutoff Frequency	0 - 255	01 7F	
43 ee 02	2	00 - 7F	reserved			
43 ee 03	1	00 - 7F	Filter Cutoff Velocity Sensitivity	-64 - +63	40	
43 ee 04	1	00 - 1F	Filter Resonance/Width/Band	0 - 31	04	
43 ee 05	1	00 - 7F	Filter Resonance Velocity Sensitivity	-64 - +63	40	
43 ee 06	2	00 - 01	HPF Cutoff Frequency	0 - 255	00 00	
43 ee 07	2	00 - 7F	reserved			
43 ee 08	1	40	reserved		40	
43 ee 09	2	00 00	reserved		00 00	
43 ee 0A	2	00 - 01	Filter Gain	0 - 255	01 7F	
43 ee 0B	2	00 - 7F	reserved			
43 ee 0C	1	00 - 7F	FEG Hold Time	0 - 127	00	
43 ee 0D	1	00 - 7F	FEG Attack Time	0 - 127	00	
43 ee 0E	1	00 - 7F	FEG Decay1 Time	0 - 127	00	
43 ee 0F	1	00 - 7F	FEG Decay2 Time	0 - 127	00	
43 ee 10	1	00 - 7F	FEG Release Time	0 - 127	00	
43 ee 11	1	00 - 7F	FEG Release Level	0 - 127	00	
43 ee 12	2	00 - 01	FEG Hold Level	-128 - +127 (-9600 + 9600[cent])	01 00	
43 ee 13	2	00 - 7F	reserved			
43 ee 14	2	00 - 01	FEG Attack Level	-128 - +127 (-9600 + 9600[cent])	01 00	
43 ee 15	2	00 - 7F	reserved			
43 ee 16	2	00 - 01	FEG Decay1 Level	-128 - +127 (-9600 + 9600[cent])	01 00	
43 ee 17	2	00 - 7F	reserved			
43 ee 18	2	00 - 01	FEG Sustain Level	-128 - +127 (-9600 + 9600[cent])	01 00	
43 ee 19	2	00 - 7F	reserved			
43 ee 1A	2	00 - 01	FEG Release Level	-128 - +127 (-9600 + 9600[cent])	01 00	
43 ee 1B	2	00 - 7F	reserved			
43 ee 1C	1	00 - 7F	FEG Depth	-64 - +63	40	
43 ee 1D	1	00 - 01	FEG Time Velocity Segment	attack_all	00	
43 ee 1E	1	00 - 7F	FEG Time Velocity Sensitivity	-64 - +63	40	
43 ee 1F	1	00 - 7F	FEG Level Velocity Sensitivity	-64 - +63	40	
43 ee 20	1	00 - 7F	Filter Cutoff Key Follow Sensitivity	-200% - +200%	40	
43 ee 21	1	00 - 7C	Filter Cutoff Scaling Break Point 1	C - 2 - E8	24	BP1-BP2-BP3-BP4
43 ee 22	1	01 - 7D	Filter Cutoff Scaling Break Point 2	C#-2 - F8	30	BP1-BP2-BP3-BP4
43 ee 23	1	02 - 7E	Filter Cutoff Scaling Break Point 3	D - 2 - F#8	3C	BP1-BP2-BP3-BP4
43 ee 24	1	03 - 7F	Filter Cutoff Scaling Break Point 4	D#-2 - G8	48	BP1-BP2-BP3-BP4
43 ee 25	2	00 - 01	Filter Cutoff Scaling Offset 1	-128 - +127	01 00	
43 ee 26	2	00 - 7F	reserved			
43 ee 27	2	00 - 01	Filter Cutoff Scaling Offset 2	-128 - +127	01 00	
43 ee 28	2	00 - 7F	reserved			
43 ee 29	2	00 - 01	Filter Cutoff Scaling Offset 3	-128 - +127	01 00	
43 ee 2A	2	00 - 7F	reserved			
43 ee 2B	2	00 - 01	Filter Cutoff Scaling Offset 4	-128 - +127	01 00	
43 ee 2C	2	00 - 7F	reserved			
43 ee 2D	1	00 - 7F	HPF Cutoff Key Follow Sensitivity	-200% - +200%	40	
43 ee 2E	1	00 - 7F	FEG Time Key Follow Sensitivity	-64 - +63	40	
43 ee 2F	1	00 - 7F	FEG Time Key Follow Center Note	C-2 - G8	3C	

TOTAL SIZE = 48 30 (HEX)

44 ee 00	1	00 - 05	EQ Type	EQ LH, PEQ, Boost6, Boost12, Boost18, thru	00	
44 ee 01	1	00 - 1F	EQ Resonance	0 - 31	00	
44 ee 02	2	00 - 01	EQ 1 Frequency	EQ LH: 46-182, PEQ: 83-251	00 53	
44 ee 03	2	00 - 7F	reserved			
44 ee 04	1	20 - 60	EQ 1 Gain	-32 - +32	40	
44 ee 05	2	00 - 01	EQ 2 Frequency	EQ LH:131-241	01 71	
44 ee 06	2	00 - 7F	reserved			
44 ee 07	1	20 - 60	EQ 2 Gain	-32 - +32	40	

TOTAL SIZE = 8 08 (HEX)

44 ee 40	1	00 - 02	LFO Wave	sqw,tri,sgu	00	
44 ee 41	1	00 - 01	LFO Key On Sync	off,on	00	
44 ee 42	1	00 - 3F	LFO Speed	0 - 63	20	
44 ee 43	1	00 - 7F	LFO AMod Depth	0 - 127	00	
44 ee 44	1	00 - 7F	LFO PMod Depth	0 - 127	00	
44 ee 45	1	00 - 7F	LFO FMod Depth	0 - 127	00	

TOTAL SIZE = 6 06 (HEX)

ee = Element Number (00_03: Element 1..4)

<付表 9 >

MIDI PARAMETER CHANGE TABLE (DRUM VOICE COMMON)

Address	Size	Data Range(HEX)	Parameter Name	Description	Default(HEX)	Notes
46 70 00	1	20 - 7E	Voice Name1	32_126(ASCII)	i	
46 70 01	1	20 - 7E	Voice Name2	32_126(ASCII)	n	
46 70 02	1	20 - 7E	Voice Name3	32_126(ASCII)	i	
46 70 03	1	20 - 7E	Voice Name4	32_126(ASCII)	t	
46 70 04	1	20 - 7E	Voice Name5	32_126(ASCII)	i	
46 70 05	1	20 - 7E	Voice Name6	32_126(ASCII)	v	
46 70 06	1	20 - 7E	Voice Name7	32_126(ASCII)	e	
46 70 07	1	20 - 7E	Voice Name8	32_126(ASCII)	i	
46 70 08	1	20 - 7E	Voice Name9	32_126(ASCII)	c	
46 70 09	1	20 - 7E	Voice Name10	32_126(ASCII)	e	
46 70 0A	1	reserved				
46 70 0B	1	reserved				
46 70 0C	1	00 - 16	Voice Category	00_22(-, Sq)	00(-)	
46 70 0D	1	reserved				
46 70 0E	1	reserved				
46 70 0F	1	reserved				
46 70 10	1	reserved				
46 70 11	1	reserved				
46 70 12	1	reserved				
46 70 13	1	00 - 7F	ARP Type	UpOct1 - GateCut3	57	
46 70 14	1	00 - 01	ARP Switch	off,on	00	
46 70 15	1	00 - 02	ARP Hold	sync-off,off,on	01	
46 70 16	1	00 - 06	ARP Unit Multiply	50%,66%,75%,100%,133%,150%,200%	03	
46 70 17	1	00 - 7F	ARP Note Limit Low	C-2_G8	00	
46 70 18	1	00 - 7F	ARP Note Limit High	C-2_G8	7F	
46 70 19	1	00 - 02	ARP Key Mode	sort,thru,direct	00	
46 70 1A	1	00 - 01	ARP Vel Mode	original,thru	01	
46 70 1B	2	0000 - 00C8	ARP Velocity Rate MSB	0..200%	64	
46 70 1C	2	0000 - 00C8	ARP Velocity Rate LSB			
46 70 1D	2	0000 - 00C8	ARP Gate Time Rate MSB	0..200%	64	
46 70 1E	2	0000 - 00C8	ARP Gate Time Rate LSB			
46 70 1F	2	0019 - 012C	ARP Tempo MSB	25..300	8A	
46 70 20	2	0019 - 012C	ARP Tempo LSB			
46 70 21	1	01 - 7F	QED Pan	L63_C_R63	40	
46 70 22	1	reserved				
46 70 23	1	00 - 7F	QED Chorus Control	-64 - +63	40	
46 70 24	1	reserved				
46 70 25	1	reserved				
46 70 26	1	reserved				
46 70 27	1	reserved				
46 70 28	1	00 - 7F	QED KnobA	-64 - +63	40	
46 70 29	1	00 - 7F	QED KnobB	-64 - +63	40	
46 70 2A	1	00 - 7F	QED KnobC	-64 - +63	40	
46 70 2B	1	00 - 7F	QED/Scene 1 Knob1	-64 - +63	40	
46 70 2C	1	00 - 7F	QED/Scene 1 Knob2	-64 - +63	40	
46 70 2D	1	00 - 7F	QED/Scene 1 Cutoff Frequency	-64 - +63	40	
46 70 2E	1	00 - 7F	QED/Scene 1 Resonance	-64 - +63	40	
46 70 2F	1	00 - 7F	QED/Scene 1 Attack Time	-64 - +63	40	
46 70 30	1	00 - 7F	QED/Scene 1 Decay Time	-64 - +63	40	
46 70 31	1	00 - 7F	Scene 2 Knob1	-64 - +63	40	
46 70 32	1	00 - 7F	Scene 2 Knob2	-64 - +63	40	
46 70 33	1	00 - 7F	Scene 2 Cutoff Frequency	-64 - +63	40	
46 70 34	1	00 - 7F	Scene 2 Resonance	-64 - +63	40	
46 70 35	1	00 - 7F	Scene 2 Attack Time	-64 - +63	40	
46 70 36	1	00 - 7F	Scene 2 Decay Time	-64 - +63	40	
46 70 37	1	00 - 7F	Scene Control	0 - 127	00	

TOTAL SIZE = 56 38 (HEX)

46 00 00	1	00 - 7F	Volume	0 - 127	7F	
46 00 01	1	reserved				
46 00 02	1	10 - 58	Pitch Bend Range Upper	-48 - +24[semitones]	42	
46 00 03	1	10 - 58	Pitch Bend Range Lower	-48 - +24[semitones]	3E	
46 00 04	1	00 - 02	Insertion Connect Type	1 2 Parameter 1, >2, >3	00	
46 00 05	1	00 - 7F	Reverb Send	---dB, 0dB	28	

Address	Size	Data Range(HEX)	Parameter Name	Description	Default(HEX)	Notes
46 03 00	2	00 - 7F	Insertion-1 Type MSB	Effect Parameter List 参照	0000	
		00 - 7F	Insertion-1 Type LSB			
46 03 02	2	00 - 7F	Insertion-1 Parameter1 MSB	"		Depends On Effect Type
		00 - 7F	Insertion-1 Parameter1 LSB			
46 03 04	2	00 - 7F	Insertion-1 Parameter2 MSB	"		
		00 - 7F	Insertion-1 Parameter2 LSB			
46 03 06	2	00 - 7F	Insertion-1 Parameter3 MSB	"		
		00 - 7F	Insertion-1 Parameter3 LSB			
46 03 08	2	00 - 7F	Insertion-1 Parameter4 MSB	"		
		00 - 7F	Insertion-1 Parameter4 LSB			
46 03 0A	2	00 - 7F	Insertion-1 Parameter5 MSB	"		
		00 - 7F	Insertion-1 Parameter5 LSB			
46 03 0C	2	00 - 7F	Insertion-1 Parameter6 MSB	"		
		00 - 7F	Insertion-1 Parameter6 LSB			
46 03 0E	2	00 - 7F	Insertion-1 Parameter7 MSB	"		
		00 - 7F	Insertion-1 Parameter7 LSB			
46 03 10	2	00 - 7F	Insertion-1 Parameter8 MSB	"		
		00 - 7F	Insertion-1 Parameter8 LSB			
46 03 12	2	00 - 7F	Insertion-1 Parameter9 MSB	"		
		00 - 7F	Insertion-1 Parameter9 LSB			
46 03 14	2	00 - 7F	Insertion-1 Parameter10 MSB	"		
		00 - 7F	Insertion-1 Parameter10 LSB			

TOTAL SIZE = 22 16 (HEX)

Address	Size	Data Range(HEX)	Parameter Name	Description	Default(HEX)	Notes
46 04 00	2	00 - 7F	Insertion-2 Type MSB	Effect Parameter List 参照	0000	
		00 - 7F	Insertion-2 Type LSB			
46 04 02	2	00 - 7F	Insertion-2 Parameter 1 MSB	"		Depends On Effect Type
		00 - 7F	Insertion-2 Parameter 1 LSB			
46 04 04	2	00 - 7F	Insertion-2 Parameter 2 MSB	"		
		00 - 7F	Insertion-2 Parameter 2 LSB			
46 04 06	2	00 - 7F	Insertion-2 Parameter 3 MSB	"		
		00 - 7F	Insertion-2 Parameter 3 LSB			
46 04 08	2	00 - 7F	Insertion-2 Parameter 4 MSB	"		
		00 - 7F	Insertion-2 Parameter 4 LSB			
46 04 0A	2	00 - 7F	Insertion-2 Parameter 5 MSB	"		
		00 - 7F	Insertion-2 Parameter 5 LSB			
46 04 0C	2	00 - 7F	Insertion-2 Parameter 6 MSB	"		
		00 - 7F	Insertion-2 Parameter 6 LSB			
46 04 0E	2	00 - 7F	Insertion-2 Parameter 7 MSB	"		
		00 - 7F	Insertion-2 Parameter 7 LSB			
46 04 10	2	00 - 7F	Insertion-2 Parameter 8 MSB	"		
		00 - 7F	Insertion-2 Parameter 8 LSB			
46 04 12	2	00 - 7F	Insertion-2 Parameter 9 MSB	"		
		00 - 7F	Insertion-2 Parameter 9 LSB			
46 04 14	2	00 - 7F	Insertion-2 Parameter 10 MSB	"		
		00 - 7F	Insertion-2 Parameter 10 LSB			
46 04 16	2	00 - 7F	Insertion-2 Parameter 11 MSB	"		
		00 - 7F	Insertion-2 Parameter 11 LSB			
46 04 18	2	00 - 7F	Insertion-2 Parameter 12 MSB	"		
		00 - 7F	Insertion-2 Parameter 12 LSB			
46 04 1A	2	00 - 7F	Insertion-2 Parameter 13 MSB	"		
		00 - 7F	Insertion-2 Parameter 13 LSB			
46 04 1C	2	00 - 7F	Insertion-2 Parameter 14 MSB	"		
		00 - 7F	Insertion-2 Parameter 14 LSB			
46 04 1E	2	00 - 7F	Insertion-2 Parameter 15 MSB	"		
		00 - 7F	Insertion-2 Parameter 15 LSB			
46 04 20	2	00 - 7F	Insertion-2 Parameter 16 MSB	"		
		00 - 7F	Insertion-2 Parameter 16 LSB			

TOTAL SIZE = 34 22 (HEX)

Address	Size	Data Range(HEX)	Parameter Name	Description	Default(HEX)	Notes
46 05 00	1	00 - 09	Controller Set1 Source	PB, MW, ..., AT, FC, FS, RB, BC, KN1, KN2	00	
46 05 01	2	00	Controller Set1 Destination MSB	0 - 29	00	
		00 - 1D	Controller Set1 Destination LSB			
46 05 03	1	00 - 7F	Controller Set1 Depth	-64 + +63	40	
46 05 04	1	reserved			00	
46 05 05	1	00 - 09	Controller Set2 Source	PB, MW, ..., AT, FC, FS, RB, BC, KN1, KN2	00	
46 05 06	2	00	Controller Set2 Destination MSB	0 - 29	00	
		00 - 1D	Controller Set2 Destination LSB			
46 05 08	1	00 - 7F	Controller Set2 Depth	-64 + +63	40	
46 05 09	1	reserved			00	
46 05 0A	1	00 - 09	Controller Set3 Source	PB, MW, ..., AT, FC, FS, RB, BC, KN1, KN2	00	
46 05 0B	2	00	Controller Set3 Destination MSB	0 - 29	00	
		00 - 1D	Controller Set3 Destination LSB			
46 05 0D	1	00 - 7F	Controller Set3 Depth	-64 + +63	40	
46 05 0E	1	reserved			00	
46 05 0F	1	00 - 09	Controller Set4 Source	PB, MW, ..., AT, FC, FS, RB, BC, KN1, KN2	00	
46 05 10	2	00	Controller Set4 Destination MSB	0 - 29	00	
		00 - 1D	Controller Set4 Destination LSB			
46 05 12	1	00 - 7F	Controller Set4 Depth	-64 + +63	40	
46 05 13	1	reserved			00	
46 05 14	1	00 - 09	Controller Set5 Source	PB, MW, ..., AT, FC, FS, RB, BC, KN1, KN2	00	
46 05 15	2	00	Controller Set5 Destination MSB	0 - 29	00	
		00 - 1D	Controller Set5 Destination LSB			
46 05 17	1	00 - 7F	Controller Set5 Depth	-64 + +63	40	
46 05 18	1	reserved			00	
46 05 19	1	00 - 09	Controller Set6 Source	PB, MW, ..., AT, FC, FS, RB, BC, KN1, KN2	00	
46 05 1A	2	00	Controller Set6 Destination MSB	0 - 29	00	
		00 - 1D	Controller Set6 Destination LSB			
46 05 1C	1	00 - 7F	Controller Set6 Depth	-64 + +63	40	
46 05 1D	1	reserved			00	

TOTAL SIZE = 30 1E (HEX)

MIDI PARAMETER CHANGE TABLE (DRUM VOICE KEY)

Address	Size	Data Range(HEX)	Parameter Name	Description	Default(HEX)	Notes
47 ee 00	1	00 - 01	Element Assign	off_on	00	*1
47 ee 01	1	00 - 03	Wave Type	wave_voice	00	
47 ee 02	1	00	reserved		00	
47 ee 03	1	00 - 01	Receive Note Off	off_on	01	
47 ee 04	1	00 - 01	Assign Mode	single_multi	01	*1
47 ee 05	1	00 - 7F	Alternate Group	0(off), 1 - 127	00	*1
47 ee 06	2	00 - 7F	Wave Number MSB	1st bit6-0 bit13-7	00	
		00 - 7F	Wave Number LSB	2nd bit6-0 bit6-0 0(off), 1 - 553	00	
47 ee 08	3	00 - 7F	Voice Bank Number MSB	0 - 127	00	*1
		00 - 7F	Voice Bank Number LSB	0 - 127	00	*1
		00 - 7F	Voice Number	0 - 127	00	*1
47 ee 0B	1	01 - 7F	Pan	L63 - C - R63	40	*1
47 ee 0C	1	00 - 7F	Random Pan Depth	0 - 127	00	
47 ee 0D	1	00 - 7F	Alternate Pan Depth	L64 - 0 - R63	40	
47 ee 0E	1	00 - 7F	Reverb Send Level	0 - 127	28	*1
47 ee 0F	1	00 - 7F	Chorus Send Level	0 - 127	00	*1
47 ee 10	1	00 - 02	Insertion Effect Switch	thru,ins1,ins2	00	*1
47 ee 11	1	reserved			00	

TOTAL SIZE = 18 12 (HEX)

Address	Size	Data Range(HEX)	Parameter Name	Description	Default(HEX)	Notes
47 ee 20	1	00 - 7F	Element Level	0 - 127	64	*1
47 ee 21	1	00 - 7F	Level Velocity Sensitivity	-64 + +63	40	
47 ee 22	1	00	reserved		00	
47 ee 23	1	00 - 7F	AEG Attack Time	0 - 127	00	
47 ee 24	1	00 - 7F	AEG Decay1 Time	0 - 127	00	
47 ee 25	1	00 - 7F	AEG Decay2 Time	0 - 126,hold	7E	
47 ee 26	1	00	reserved		00	
47 ee 27	1	00	reserved		00	
47 ee 28	1	00	reserved		00	
47 ee 29	1	00 - 7F	AEG Decay1 Level	0 - 127	7F	
47 ee 2A	1	00	reserved		00	
47 ee 2B	1	00	reserved		00	

TOTAL SIZE = 12 0C (HEX)

Address	Size	Data Range(HEX)	Parameter Name	Description	Default(HEX)	Notes
48 ee 00	1	10 - 70	Coarse Tune	-48 + +48	40	*1
48 ee 01	1	00 - 7F	Fine Tune	-64 + +63	40	*1
48 ee 02	1	00 - 7F	Pitch Velocity Sensitivity	-64 + +63	40	

TOTAL SIZE = 3 03 (HEX)

Address	Size	Data Range(HEX)	Parameter Name	Description	Default(HEX)	Notes
49 ee 00	1	00	reserved		00	
49 ee 01	2	00 - 01	LPF Cutoff Frequency MSB	0 - 255	01 7F	
		00 - 7F	LPF Cutoff Frequency LSB			
49 ee 03	1	00 - 7F	LPF Cutoff Velocity Sensitivity	-64 + +63	00	
49 ee 04	1	00 - 1F	LPF Resonance	0 - 31	04	
49 ee 05	1	40	reserved		40	
49 ee 06	2	00 - 01	HPF Cutoff Frequency MSB	0 - 255	00 00	
		00 - 7F	HPF Cutoff Frequency LSB			

TOTAL SIZE = 8 08 (HEX)

Address	Size	Data Range(HEX)	Parameter Name	Description	Default(HEX)	Notes
4A ee 00	1	00 - 05	EQ Type	EQ LH, P.EQ, Boost6, Boost12, Boost18, thru	00	
4A ee 01	1	00 - 1F	EQ Resonance	0 - 31	00	
4A ee 02	2	00 - 01	EQ 1 Frequency MSB	EQ LH: 46-182, P.EQ: 83-251	00 53	
		00 - 7F	EQ 1 Frequency LSB			
4A ee 04	1	20 - 60	EQ 1 GAIN	-32 + +32	40	
4A ee 05	2	00 - 01	EQ 2 Frequency MSB	EQ LH:131-241	01 71	
		00 - 7F	EQ 2 Frequency LSB			
4A ee 07	1	20 - 60	EQ 2 GAIN	-32 + +32	40	

TOTAL SIZE = 8 08 (HEX)

ee = Element Number (00 - 48: C0 - C6)

*1: Wave/Voice Type を voice にした場合は、このパラメーターのみ有効。

<付表10>

MIDI PARAMETER CHANGE TABLE (PLUGIN VOICE)

Address	Size	Data Range(HEX)	Parameter Name	Description	Default(HEX)	Notes
4C7000	1	20-7E	Voice Name1	32_126(ASCII)	-	
4C7001	1	20-7E	Voice Name2	32_126(ASCII)	-	
4C7002	1	20-7E	Voice Name3	32_126(ASCII)	-	
4C7003	1	20-7E	Voice Name4	32_126(ASCII)	-	
4C7004	1	20-7E	Voice Name5	32_126(ASCII)	-	
4C7005	1	20-7E	Voice Name6	32_126(ASCII)	-	
4C7006	1	20-7E	Voice Name7	32_126(ASCII)	-	
4C7007	1	20-7E	Voice Name8	32_126(ASCII)	-	
4C7008	1	20-7E	Voice Name9	32_126(ASCII)	-	
4C7009	1	20-7E	Voice Name10	32_126(ASCII)	-	
4C700A	1		reserved			
4C700B	1		reserved			
4C700C	1	00-16	Voice Category	00_22(-..._Sq)	00(-)	
4C700D	1		reserved			
4C700E	1		reserved			
4C700F	1		reserved			
4C7010	1		reserved			
4C7011	1		reserved			
4C7012	1		reserved			
4C7013	1	00-7F	ARP Type	UjOct1 - GateCut3	00	
4C7014	1	00-01	ARP Switch	off.on	00	
4C7015	1	00-02	ARP Hold	sync-off.off.on	01	
4C7016	1	00-06	ARP Unit Multiply	50%,66%,75%,100%,133%,150%,200%	03	
4C7017	1	00-7F	ARP Note Limit Low	C-2_G8	00	
4C7018	1	00-7F	ARP Note Limit High	C-2_G8	7F	
4C7019	1	00-02	ARP Key Mode	sort.thru.direct	00	
4C701A	1	00-01	ARP Vel Mode	original.thru	00	
4C701B	2	0000-00C8	ARP Velocity Rate MSB ARP Velocity Rate LSB	0_200%	64	
4C701D	2	0000-00C8	ARP Gate Time Rate MSB ARP Gate Time Rate LSB	0_200%	64	
4C701F	2	0019-012C	ARP Tempo MSB ARP Tempo LSB	25_300	8A	
4C7021	1	01-7F	QED Pan	L63_C_R63	40	
4C7022	1		reserved			
4C7023	1	00-7F	QED Chorus Control	-64_+63	40	
4C7024	1	00-7F	QED Release Time	-64_+63	40	
4C7025	1		reserved			
4C7026	1		reserved			
4C7027	1		reserved			
4C7028	1	00-7F	QED KnobA	-64_+63	40	
4C7029	1	00-7F	QED KnobB	-64_+63	40	
4C702A	1	00-7F	QED KnobC	-64_+63	40	
4C702B	1	00-7F	QED/Scene 1 Knob1	-64_+63	40	
4C702C	1	00-7F	QED/Scene 1 Knob2	-64_+63	40	
4C702D	1	00-7F	QED/Scene 1 Cutoff Frequency	-64_+63	40	
4C702E	1	00-7F	QED/Scene 1 Resonance	-64_+63	40	
4C702F	1	00-7F	QED/Scene 1 Attack Time	-64_+63	40	
4C7030	1	00-7F	QED/Scene 1 Decay Time	-64_+63	40	
4C7031	1	00-7F	Scene 2 Knob1	-64_+63	40	
4C7032	1	00-7F	Scene 2 Knob2	-64_+63	40	
4C7033	1	00-7F	Scene 2 Cutoff Frequency	-64_+63	40	
4C7034	1	00-7F	Scene 2 Resonance	-64_+63	40	
4C7035	1	00-7F	Scene 2 Attack Time	-64_+63	40	
4C7036	1	00-7F	Scene 2 Decay Time	-64_+63	40	
4C7037	1	00-7F	Scene Control	0_127	00	
TOTAL SIZE = 56 38 (HEX)						

4C0000	1	00-7F	Volume	0-127	64	
4C0001	1		reserved		01	
4C0002	1	00-01	Same Note Number Key On Assign	single,multi	01	
4C0003	1	00-01	Mono/Poly Mode	mono,poly	01	
4C0004	1		reserved		00	
4C0005	1	28-58	Pitch Bend Range	-24_+24[semitones]	42	
4C0006	1		reserved		3E	
4C0007	1		reserved		00	
4C0008	1	00-01	Portamento Switch	off.on	00	
4C0009	1	00-7F	Portamento Time	0-127	40	
4C000A	1		reserved		00	
4C000B	1	00-7F	Reverb Send	--dB...0dB	00	
4C000C	1	00-7F	Chorus Send	--dB...0dB	00	
TOTAL SIZE = 13 0D (HEX)						

4C0100	2	00-7F	Reverb Type MSB	Effect Parameter List 参照	0100	
4C0101	2	00-7F	Reverb Type LSB			
4C0102	2	00-7F	Reverb Parameter 1 MSB	#	init value for hall1	
4C0103	2	00-7F	Reverb Parameter 1 LSB	#		
4C0104	2	00-7F	Reverb Parameter 2 MSB	#	init value for hall1	
4C0105	2	00-7F	Reverb Parameter 2 LSB	#		
4C0106	2	00-7F	Reverb Parameter 3 MSB	#	init value for hall1	
4C0107	2	00-7F	Reverb Parameter 3 LSB	#		
4C0108	2	00-7F	Reverb Parameter 4 MSB	#	init value for hall1	
4C0109	2	00-7F	Reverb Parameter 4 LSB	#		
4C010A	2	00-7F	Reverb Parameter 5 MSB	#	init value for hall1	
4C010B	2	00-7F	Reverb Parameter 5 LSB	#		
4C010C	2	00-7F	Reverb Parameter 6 MSB	#	init value for hall1	
4C010D	2	00-7F	Reverb Parameter 6 LSB	#		
4C010E	2	00-7F	Reverb Parameter 7 MSB	#	init value for hall1	
4C010F	2	00-7F	Reverb Parameter 7 LSB	#		
4C0110	2	00-7F	Reverb Parameter 8 MSB	#	init value for hall1	
4C0111	2	00-7F	Reverb Parameter 8 LSB	#		
4C0112	2	00-7F	Reverb Parameter 9 MSB	#	init value for hall1	
4C0113	2	00-7F	Reverb Parameter 9 LSB	#		
4C0114	2	00-7F	Reverb Parameter 10 MSB	#	init value for hall1	
4C0115	2	00-7F	Reverb Parameter 10 LSB	#		
4C0116	1	00-7F	Reverb Return	--dB...0dB +6dB(0_96...127)	40	
4C0117	1	01-7F	Reverb Pan	L63_C_R63	40	
TOTAL SIZE = 24 18 (HEX)						

4C0200	2	00-7F	Chorus Type MSB	Effect Parameter List 参照	0500	
4C0201	2	00-7F	Chorus Type LSB			
4C0202	2	00-7F	Chorus Parameter 1 MSB	#	init value for chorus1	
4C0203	2	00-7F	Chorus Parameter 1 LSB	#		
4C0204	2	00-7F	Chorus Parameter 2 MSB	#	init value for chorus1	
4C0205	2	00-7F	Chorus Parameter 2 LSB	#		
4C0206	2	00-7F	Chorus Parameter 3 MSB	#	init value for chorus1	
4C0207	2	00-7F	Chorus Parameter 3 LSB	#		
4C0208	2	00-7F	Chorus Parameter 4 MSB	#	init value for chorus1	
4C0209	2	00-7F	Chorus Parameter 4 LSB	#		
4C020A	2	00-7F	Chorus Parameter 5 MSB	#	init value for chorus1	
4C020B	2	00-7F	Chorus Parameter 5 LSB	#		
4C020C	2	00-7F	Chorus Parameter 6 MSB	#	init value for chorus1	
4C020D	2	00-7F	Chorus Parameter 6 LSB	#		
4C020E	2	00-7F	Chorus Parameter 7 MSB	#	init value for chorus1	
4C020F	2	00-7F	Chorus Parameter 7 LSB	#		
4C0210	2	00-7F	Chorus Parameter 8 MSB	#	init value for chorus1	
4C0211	2	00-7F	Chorus Parameter 8 LSB	#		
4C0212	2	00-7F	Chorus Parameter 9 MSB	#	init value for chorus1	
4C0213	2	00-7F	Chorus Parameter 9 LSB	#		
4C0214	2	00-7F	Chorus Parameter 10 MSB	#	init value for chorus1	
4C0215	2	00-7F	Chorus Parameter 10 LSB	#		
4C0216	1	00-7F	Chorus Return	--dB...0dB +6dB(0_96...127)	40	
4C0217	1	01-7F	Chorus Pan	L63_C_R63	40	
4C0218	1	00-7F	Send Chorus To Reverb	--dB...0dB(0_127)	00	
TOTAL SIZE = 25 19 (HEX)						

Address	Size	Data Range(HEX)	Parameter Name	Description	Default(HEX)	Notes
4C0300	2	00-7F	Insertion Type MSB	Effect Parameter List 参照	0000	
4C0301	2	00-7F	Insertion Type LSB			
4C0302	2	00-7F	Insertion Parameter1 MSB	#	0000	
4C0303	2	00-7F	Insertion Parameter1 LSB	#		
4C0304	2	00-7F	Insertion Parameter2 MSB	#	0000	
4C0305	2	00-7F	Insertion Parameter2 LSB	#		
4C0306	2	00-7F	Insertion Parameter3 MSB	#	0000	
4C0307	2	00-7F	Insertion Parameter3 LSB	#		
4C0308	2	00-7F	Insertion Parameter4 MSB	#	0000	
4C0309	2	00-7F	Insertion Parameter4 LSB	#		
4C030A	2	00-7F	Insertion Parameter5 MSB	#	0000	
4C030B	2	00-7F	Insertion Parameter5 LSB	#		
4C030C	2	00-7F	Insertion Parameter6 MSB	#	0000	
4C030D	2	00-7F	Insertion Parameter6 LSB	#		
4C030E	2	00-7F	Insertion Parameter7 MSB	#	0000	
4C030F	2	00-7F	Insertion Parameter7 LSB	#		
4C0310	2	00-7F	Insertion Parameter8 MSB	#	0000	
4C0311	2	00-7F	Insertion Parameter8 LSB	#		
4C0312	2	00-7F	Insertion Parameter9 MSB	#	0000	
4C0313	2	00-7F	Insertion Parameter9 LSB	#		
4C0314	2	00-7F	Insertion Parameter10 MSB	#	0040	
4C0315	2	00-7F	Insertion Parameter10 LSB	#		
TOTAL SIZE = 22 16 (HEX)						

4C0500	1	00-09	Controller Set1 Source	PB_MW_... AT_FC_FS_RB_BC_KN1_KN2	00	
4C0501	2	00	Controller Set1 Destination MSB	0-13	00	
4C0502	2	00-0D	Controller Set1 Destination LSB		00	
4C0503	1	00-7F	Controller Set1 Depth	-64_+63	40	
4C0504	1		reserved		00	
4C0505	1	00-09	Controller Set2 Source	PB_MW_... AT_FC_FS_RB_BC_KN1_KN2	00	
4C0506	2	00	Controller Set2 Destination MSB	0-13	00	
4C0507	2	00-0D	Controller Set2 Destination LSB		00	
4C0508	1	00-7F	Controller Set2 Depth	-64_+63	40	
4C0509	1		reserved		00	
TOTAL SIZE = 10 0A (HEX)						

4C1000	1	00-7F	Voice Bank MSB	0_127		depends on plug-in board
4C1001	1	00-7F	Voice Bank LSB	0_127		depends on plug-in board
4C1002	1	00-7F	Voice Number	0_127		depends on plug-in board
4C1003	1	28-58	Note Shift	-24_0_+24[semitones]	40	
4C1004	1	00-7F	Velocity Sense Depth	0_127	40	
4C1005	1	00-7F	Velocity Sense Offset	0_127	40	
4C1006	1	00-7F	(Vibrato Rate) LFO Speed	-64_+63	40	
4C1007	1	00-7F	(Vibrato Depth) LFO Pitch Depth	-64_+63	40	
4C1008	1	00-7F	(Vibrato Delay) LFO Delay	-64_+63	40	
4C1009	1	00-7F	MW Filter Control	-64_+63	40	
4C100A	1		reserved	0	0A	
4C100B	1	00-7F	MW LFO Pitch Modulation Depth	0_127	00	
4C100C	1	00-7F	MW LFO Filter Modulation Depth	0_127	00	
4C100D	1	00-7F	MW LFO Amplitude Modulation Depth	0_127	00	
4C100E	1	28-58	CAT Pitch Control	-24_+24[semitones]	40	
4C100F	1	00-7F	CAT Filter Control	-64_+63	40	
4C1010	1		reserved	-64_+63	40	
4C1011	1	00-7F	CAT LFO Pitch Modulation Depth	0_127	00	
4C1012	1	00-7F	CAT LFO Filter Modulation Depth	0_127	00	
4C1013	1	00-7F	CAT LFO Amplitude Modulation Depth	0_127	00	
4C1014	1	00-5F	AC1 Controller Number	0_95	10	
4C1015	1	00-7F	AC1 Filter Control	-64_+63	40	
4C1016	1		reserved	-64_+63	40	
4C1017	1	00-7F	AC1 LFO Pitch Modulation Depth	0_127	00	
4C1018	1	00-7F	AC1 LFO Filter Modulation Depth	0_127	00	
4C1019	1	00-7F	AC1 LFO Amplitude Modulation Depth	0_127	00	
4C101A	1	00-7F	Pitch EG Initial Level	-64_+63	40	
4C101B	1	00-7F	Pitch EG Attack Time	-64_+63	40	
4C101C	1	00-7F	Pitch EG Release Level	-64_+63	40	
4C101D	1	00-7F	Pitch EG Release Time	-64_+63	40	
4C101E	1	00-7F	EQ Low Gain	-64_+63(-12_+12[dB])	40	
4C101F	1	00-7F	EQ High Gain	-64_+63(-12_+12[dB])	40	
4C1020	1	04-28	EQ Low Frequency	32_2.0kHz	0C	
4C1021	1	1C-3A	EQ High Frequency	500_16.0kHz	36	
4C1022	1	00-7F	HPF Cutoff Frequency	-64_0_+63	40	
TOTAL SIZE = 35 23 (HEX)						

4C2000	64	00-7F	Plug-in Board Native Parameter	depends on Plug-in Board	00	
4C2040	3	00-7F	Plug-in Board Type MSB			depends on plug-in board
4C2041	3	00-7F	Plug-in Board Type LSB			depends on plug-in board
4C2042	3	00-7F	Plug-in Board Version Number			depends on plug-in board
4C2043	1	00-7F	reserved		00	
TOTAL SIZE = 68 44 (HEX)						

Function...	Transmitted	Recognized	Remarks
Basic Channel Default Changed	1 - 16 1 - 16	1 - 16 1 - 16	Memorised
Mode Default Messages Altered	3 X *****	1 1 - 4(m=1) *2 X	Memorised
Note Number : True voice	0 - 127 *****	0 - 127 0 - 127	Transpose
Velocity Note ON Note OFF	O 9nH,v=1-127 X 9nH,v=0	O v=1-127 X	
After Touch Key's Ch's	X O	X O	*1
Pitch Bend	O	O	*1
Control Change 0,32 1,7,11 5,10 6,38 64 65 66 71-75 91,93 96-97 100-101 1-95	O X X X X X X X X X X X O	O O O O O O O O O O O O O	*1 *1 *1 *1 *1 *1 *1 *1 *1 *1 *1 *1 *1 Data Entry Sustain Sw Portamento Sw Sosutenuto Sound Controller Effect Depth RPN Inc,Dec RPN LSB,MSB Assignable Cntrl
Prog Change : True #	O 0 - 127 *****	O 0 - 127 0 - 127	
System Exclusive	O	O	
Common : Song Pos. : Song Sel. : Tune	X X X	X X X	
System : Clock Real Time : Commands	X X	O X	
Aux : All Sound Off : Reset All Cntrls : Local ON/OFF Mes- : All Notes OFF sages: Active Sense : Reset	X X X X O X	O (120,126,127) O (121) X O (123-125) O X	
Notes:	*1 receive if switch is on. *2 m is always treated as "1" regardless of its value.		

Function...	Transmitted	Recognized	Remarks
Basic Channel Default Changed	1 - 16 X	X X	Memorised
Mode Default Messages Altered	X X *****	X X X	
Note Number : True voice	0 - 127 *****	X X	
Velocity Note ON Note OFF	O 9nH,v=1-127 X 9nH,v=0	X X	
After Touch Key's Ch's	O O	X X	
Pitch Bend	O	X	
Control Change 0-121	O	X	
Prog Change : True #	O 0 - 127 *****	X	
System Exclusive	O	X	
Common : Song Pos. : Song Sel. : Tune	X X X	X X X	
System : Clock Real Time : Commands	O *2 O *2	O *1 *2 O *2	
Aux : All Sound Off : Reset All Cntrls : Local ON/OFF Mes- : All Notes OFF sages: Active Sense : Reset	O O O O O X	X X X X X X	
Notes: *1 if MIDI Sync is midi *2 if MIDI Control in is on			

Mode 1 : OMNI ON , POLY
 Mode 3 : OMNI OFF, POLY

Mode 2 : OMNI ON ,MONO
 Mode 4 : OMNI OFF,MONO

O : Yes
 X : No

ヤマハ株式会社



この取扱説明書は
エコパルプ(ECF:無塩素系漂白パルプ)
を使用しています。



この取扱説明書は
大豆油インクで印刷しています。

M.D.G., PA•DMI Division, Yamaha Corporation
© 2000 Yamaha Corporation

V568530 005MWDN6.2-02A0