



YAMAHA

L2

L3

L4

L5

TENORI-ON

Q U I C K G U I D E

TNR-W

designed by Toshio Iwai & Yamaha



TENORI-ON 
LAYER▶01-Score BLOC▶01
INST▶01/01:Photon
TIME▶00:00:00  STOP

● Supplied Items (Please check that these are included.)

- The TENORI-ON instrument**
- AC Adaptor**
(PA-3C, PA-130 or equivalent Yamaha adaptor)
*May not be included depending on your particular area. Please check with your Yamaha dealer.
- MIDI cable** (Mini MIDI DIN – MIDI IN/OUT)
- CD-ROM**
- Quick Guide** (This document)
- Installation Guide**
- Precautions**

CONTENTS

- 03 **TENORI-ON Hardware and Nomenclature**
- 04 **Connecting the TENORI-ON to External Devices**
- 05 **Power Supply Preparation and Switching On / TENORI-ON Performance Styles**
- 06 **Basic TENORI-ON Operation: Score Mode**
- 08 **Basic TENORI-ON Operation: Function Buttons**
- 12 **Layers and the Performance Modes**
- 13 **Random Mode (Layer 08—11)**
- 14 **Draw Mode (Layer 12, 13) / Bounce Mode (Layer 14)**
- 15 **Push Mode (Layer 15) / Solo Mode (Layer 16)**
- 16 **Using Blocks**
- 18 **Using the Menu**
- 20 **Menu List**
- 22 **Song Recording and Playback**
- 23 **Using Original Samples**
- 24 **The TENORI-ON as “Interior Decoration”**
- 26 **TENORI-ON Score Sheet**
- 27 **TENORI-ON Specifications**

● About the Manuals

The TENORI-ON is provided with the four manuals listed below.

● Quick Guide

The Quick Guide provides instructions on setup and basic operation that will get you started as quickly as possible.

● TENORI-ON Manual

The manual is provided as an electronic document on the supplied CD-ROM, and it provides detailed descriptions and procedures that will help you take full advantage of the TENORI-ON's many advanced features. Refer to the Quick Guide for basic information such as turning on the power, the functions of the panel controls, and more.

● Precautions

This document lists a number of points you need to be aware of in order to use the TENORI-ON properly and safely. Please read it carefully. Yamaha representative and authorized distributor contact details are also included.

● Installation Guide

Explains the procedure for installing the “TENORI-ON User Voice Manager” software that is included on the supplied CD-ROM on your computer.

● About the Supplied CD-ROM

In addition to a pdf manual and demo movie, the CD-ROM includes the “TENORI-ON User Voice manager” software for Windows and Macintosh computers.

- The illustrations and LCD screens as shown in this manual are for instructional purposes only, and may appear somewhat different from those on your instrument.
-  is a registered trademark of the SD Card Association.
- This product incorporates and bundles computer programs and contents in which Yamaha owns copyrights or with respect to which it has license to use others' copyrights. Such copyrighted materials include, without limitation, all computer software, style files, MIDI files, WAVE data, musical scores and sound recordings. Any unauthorized use of such programs and contents outside of personal use is not permitted under relevant laws. Any violation of copyright has legal consequences. DON'T MAKE, DISTRIBUTE OR USE ILLEGAL COPIES.



Backup and Initialization

Some data will be lost when the power is turned off. Save important data to an SD Memory Card using the Save All Blocks function (TENORI-ON Manual, page 69) before turning off. See page 39 of the manual for the initialization procedure.



Increasing the volume excessively may cause some voices to distort. In this case, lower the volume accordingly, or use an external audio system.

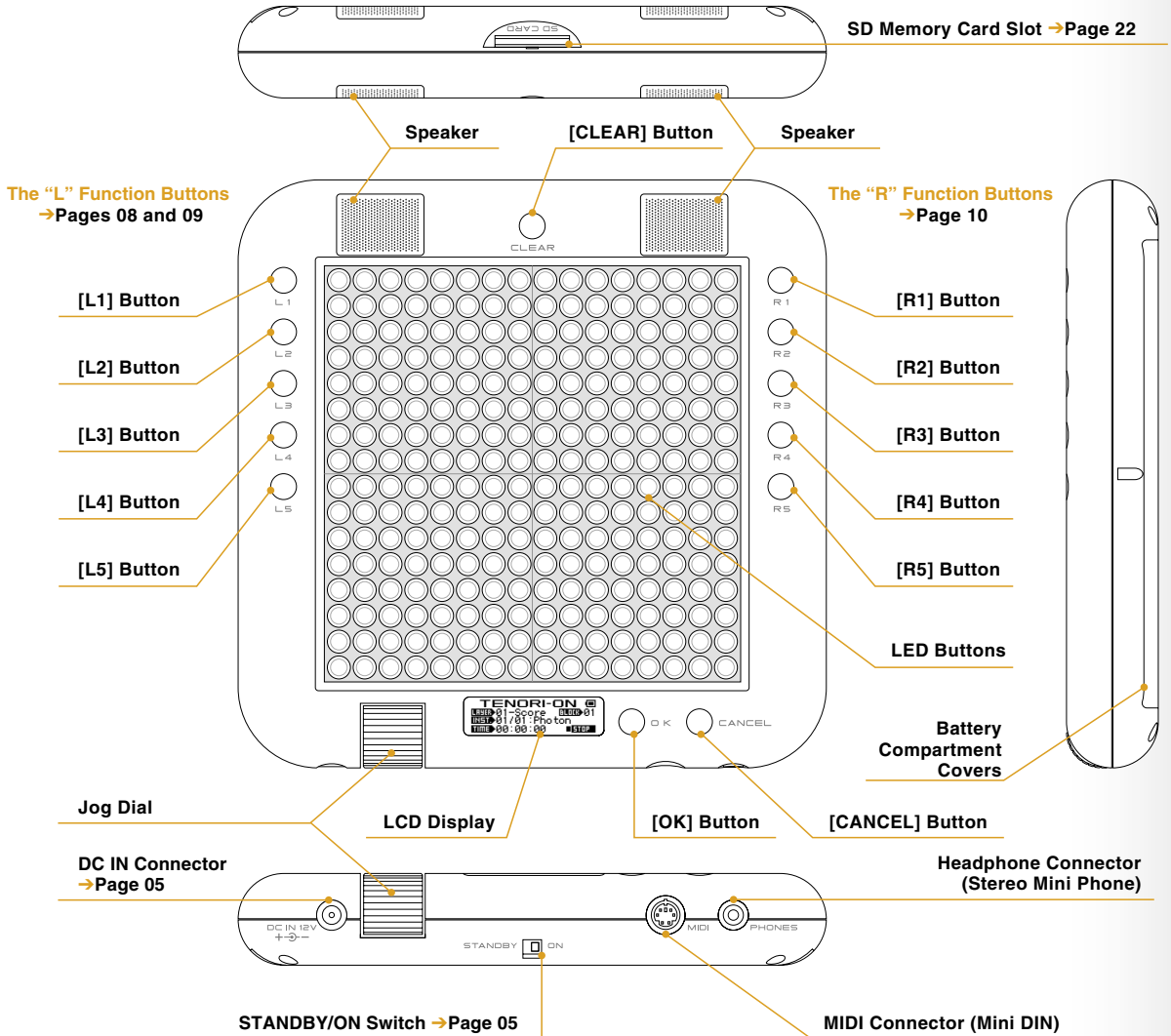

Connecting the TENORI-ON to External Devices

SD Memory Card



Save and load TENORI-ON performances and settings, or transfer original voice samples to the TENORI-ON from your computer. SD Memory Cards are also a handy way for TENORI-ON users to share data.

- The TENORI-ON is not supplied with an SD Memory Card. Purchase SD Memory Cards (2 gigabyte capacity or less) at appropriate retail outlets.

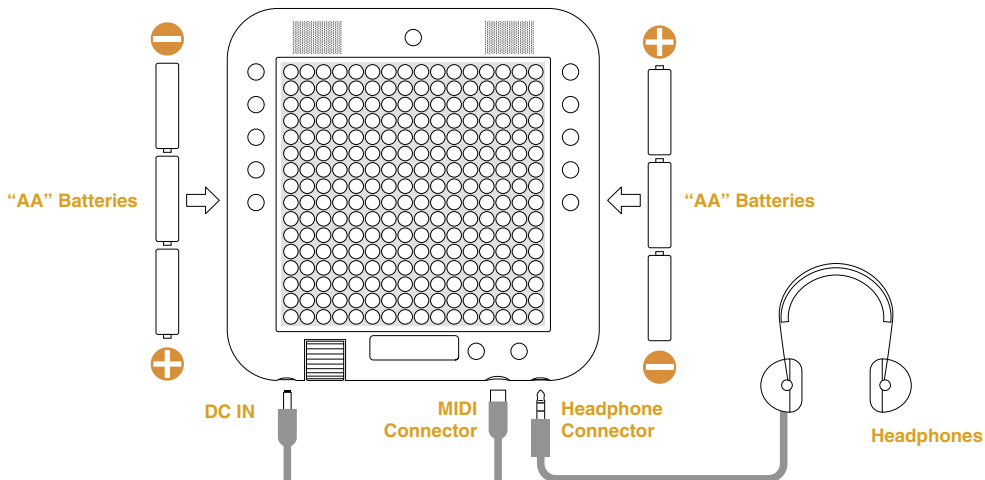

With the supplied MIDI Cable connected to the MIDI connector it is possible to connect multiple TENORI-ON instruments for synchronized performance, or connect to a computer which can be used to record the instrument's MIDI output. These operations may also require one or more optional MIDI cables and a UX16 USB-MIDI Interface.

For maximum audio impact either use a pair of headphones to monitor the TENORI-ON sound, or use the headphone connector to connect it to an audio system.

⚠ Avoid listening with the headphones at high volume for long periods of time; doing so may not only result in ear fatigue, it may be damaging to your hearing.

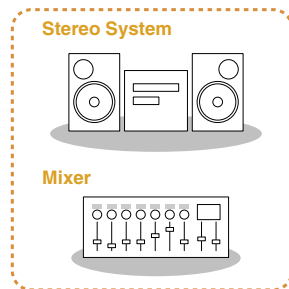
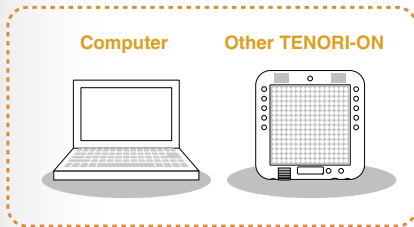

Power Supply

Either the supplied AC Adaptor (PA-3C, PA-130 or equivalent Yamaha adaptor) or six "AA" alkaline batteries can be used to power the TENORI-ON.

Connecting the AC Adaptor

Make sure the TENORI-ON STANDBY/ON switch is set to the STANDBY position. Connect the AC adaptor DC plug to the DC IN connector, and then plug the AC adaptor's AC plug into an appropriate AC power outlet.

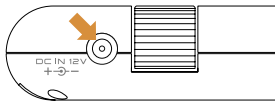

! Use only the supplied PA-3C, PA-130 or an equivalent Yamaha AC adaptor.

! Use only alkaline batteries when powering the TENORI-ON from batteries.

Installing Batteries

Make sure the TENORI-ON STANDBY/ON switch is set to the STANDBY position, and remove the battery compartment covers (there are two battery compartment covers) from either side of the back of the instrument. Install six "AA" alkaline type batteries, three on each side, with the orientation shown in the illustration and replace the battery compartment covers.

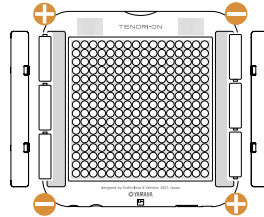

Switching On

Slide the STANDBY/ON Switch to the ON position to turn the power on.

When the power is turned on the status information will appear on the LCD display, with the power status indicator in the upper right corner.

- When using the AC adaptor.



- When using batteries.



Full



Half Full



Almost Depleted



Depleted

! When the power status indicator shows that the batteries are almost depleted  replace all six batteries with new ones as soon as possible.

! If the batteries fail during a data store operation, not only might the data being transferred be lost but the data in the destination may be lost or corrupted as well. Use the AC adaptor when transferring data.

Performance Styles

Hand-held Performance

Hold the TENORI-ON firmly on both sides. You should be able to use your thumbs to operate the function buttons, LED buttons, and the jog dial.

If you can't reach some of the LED buttons with your thumbs, or need to maximum operation speed, you can alternatively hold the TENORI-ON firmly with one hand while operating the LED buttons with your free hand.

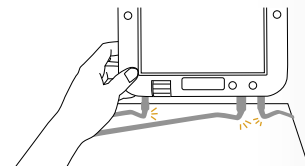

Table-top Performance

The TENORI-ON can be operated while placed on a table, desk, or any stable flat surface.



! Be careful not to bend the cables beneath the device or apply excessive pressure on them. Doing so can damage the cable and connectors.



TENORI-ON “Modes”

The TENORI-ON 16 x 16 LED button matrix is simultaneously a performance input controller and display. By operating and interacting with the LED buttons and the light they produce you gain access to the TENORI-ON's numerous performance capabilities.

The TENORI-ON provides six different performance and sound/light modes for broad performance versatility, and these modes can be combined and used simultaneously for rich, complex musical expression.

The Six Modes

Score Mode	
Random Mode	→Page 13
Draw Mode	→Page 14
Bounce Mode	→Page 14
Push Mode	→Page 15
Solo Mode	→Page 15

The Score Mode

The Score Mode is the basic TENORI-ON performance mode. In this mode the TENORI-ON interface functions like a musical “score” on which you can write the notes to be played in one musical measure via the 16 x 16 LED button matrix. The time axis of the score proceeds from left to right (the horizontal axis), beginning at the left edge of the matrix and then looping back to the beginning once the right edge of the matrix is reached. The vertical axis corresponds to the pitch of the notes played. If more than one note is entered on the same vertical line, for example, those notes will be played simultaneously as an interval or chord. The maximum number of notes or intervals/chords that can be entered horizontally is 16, but within that range the number and playback speed can be set as required, allowing the creation of complex groupings when multiple Score-Mode layers are combined.

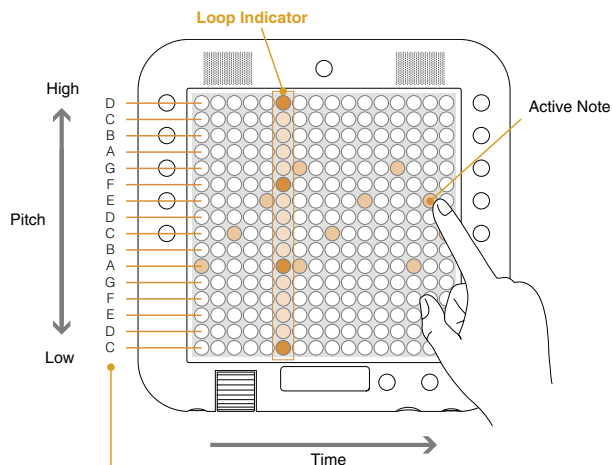

• The factory default note settings correspond to the white keys on a piano. Semitone adjustments can be made from the menu. Refer to the “Master Scale” section on page 44 of the TENORI-ON Manual on the supplied CD-ROM.

Performance in the Score Mode

Press an LED button briefly to play the sound assigned to it. At the same time the lights will flash outward from the played sound. If you hold the LED button a bit longer it will remain lit and will become an active note that will play repeatedly. Press and hold an active note to de-activate it.

The loop indicator will be continuously cycling from the left to right edge of the LED button matrix. Active notes will play when the loop indicator coincides with their positions on the matrix.

- Press the [CLEAR] button to de-activate all active notes.

Active notes will play and flash when the loop indicator passes over them.

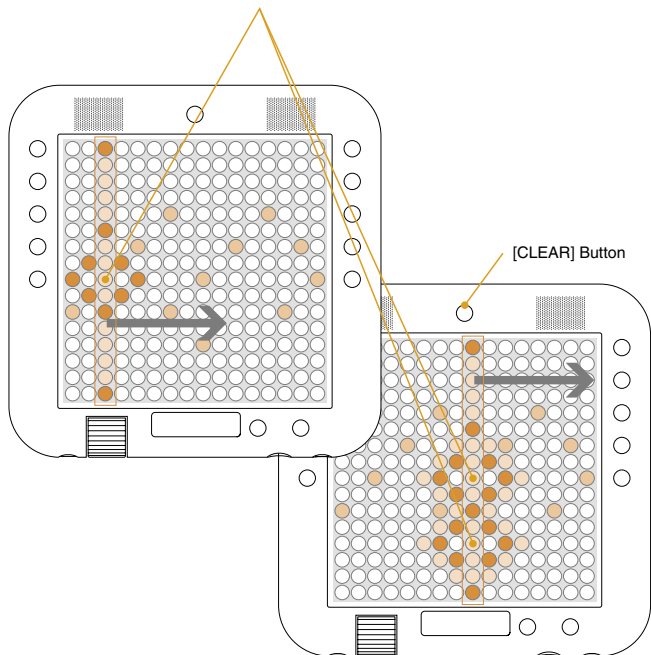

Master Volume Adjustment

To adjust the overall volume of the TENORI-ON, rotate the jog dial while holding the [R4] function button. The volume setting will appear in the LCD display.

- This volume setting is temporary. Refer to page 43 in the TENORI-ON Manual (pdf file) for details on setting the overall "hardware" volume.

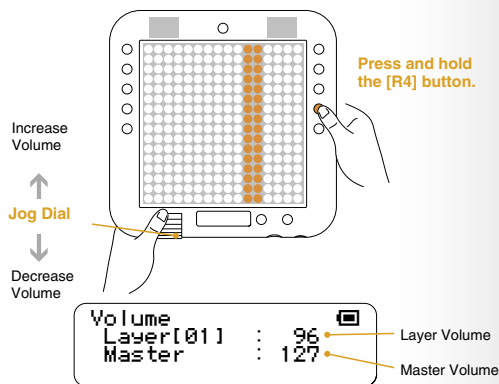

Pausing Loop Playback

Press the [OK] button while the highlighted "STOP" indicator in the lower right corner of the LCD display is shown to temporarily pause loop playback. The loop indicator will stop at the position at which the [OK] button is pressed, and the highlighted "STOP" indicator will change to "START." Press the [OK] button a second time and loop playback will resume from the point at which it was paused.

Current loop indicator position.

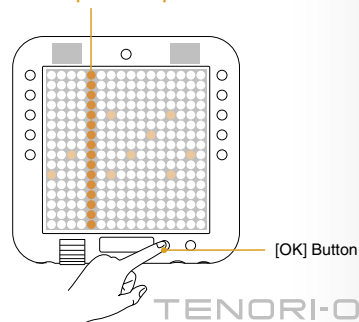

Functions

By holding one of the ten function buttons located on either side of the TENORI-ON and operating the LED buttons you can change voices, change octaves, and apply a variety of effects and variations to your performance.

This unique visual/tactile interface has been specifically designed to allow intuitive, instantaneous operation of a variety of functions.

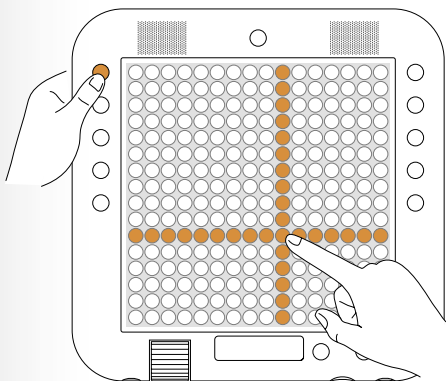

Operate the LED buttons while holding a function button.

L1 + LED Buttons: Changing Voices

You can select any voice from the 256 voices available in one quick operation. When you press and hold the [L1] button vertical and horizontal lines will light on the matrix, and the button at their intersection corresponds to the currently selected voice. If you press a different LED button while these crossed lines are showing the intersection will move to that button and the corresponding voice will be selected.

Matrix with voice number 06/10 selected.

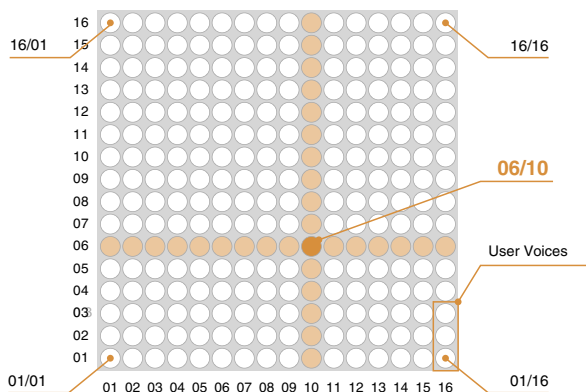

- The voice number and name will appear in the LCD display. The voice number corresponds to the vertical and horizontal button numbers.
- The TENORI-ON has 253 internal voices. The remaining three voices (numbers <01/16>, <02/16>, and <03/16>) are "user voices" that can be created by you and loaded into the TENORI-ON via an SD Memory Card (→page 23).

L2 + LED Buttons: Changing Note Length

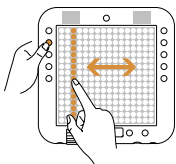

Sets the length of the notes from the time they are triggered to the time they decay to silence (the gate time). While holding the [L2] button slide your finger horizontally over the matrix to move the lit vertical line to the desired setting. Moving the line to the right increases the note length.

- Not available in the Push Mode.

L3 + LED Buttons: Changing Octaves

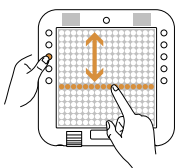

Sets the playback pitch in octave increments. While holding the [L3] button slide your finger vertically over the matrix to move the lit horizontal line to the desired octave.

L4 + LED Buttons: Changing Loop Points

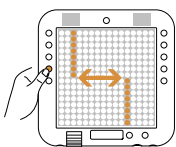

Sets the loop playback range in the Score Mode. While holding the [L4] button slide your finger horizontally over upper half of the matrix to move the loop start point indicator to the desired point, and slide your finger horizontally over lower half of the matrix to move the loop end point indicator to the desired point, as required.

- In the Random Mode this function sets the rotation direction and speed (→page 13).
- Not available in the Draw, Bounce, Push and Solo Modes.

L5 + LED Buttons: Changing Loop Speed

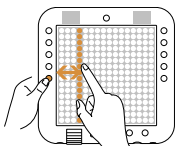

Sets the loop playback speed (the duration of the beats). Four settings are available, set via the leftmost four columns on the matrix: quarter notes, eighth notes, sixteenth notes, and thirty-second notes. While holding the [L5] button press a button in the corresponding column.

- Not available in the Push Mode.

L 1

L 2

L 3

L 4

L 5

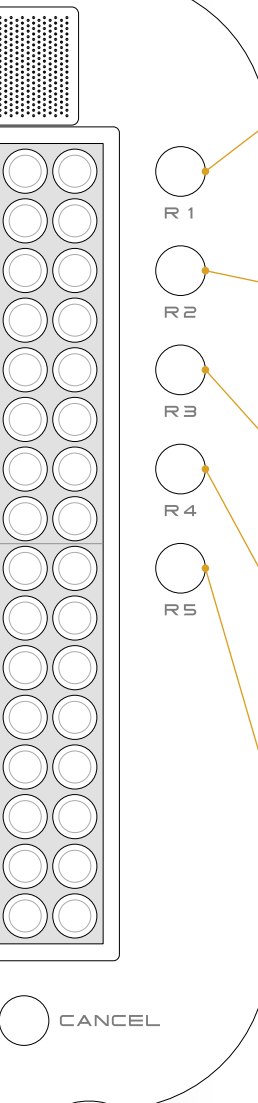

R1 + LED Buttons: **Switching Layers**

Switches to a different layer.
While holding the [R1] button slide your finger vertically over the matrix to move the lit horizontal line to the desired layer.
Moving the line to the lowest row selects layer 01, the next row up is layer 02, then layer 03, and so on up to layer 16.

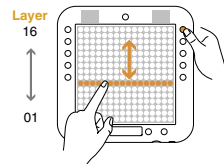

R2 + LED Buttons: **Changing Tempo**

Sets the playback tempo (BPM).
While holding the [R2] button slide your finger horizontally over the matrix to move the lit vertical line to the desired tempo setting. Moving the line to the right produces faster tempos.

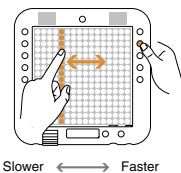

R3 + LED Buttons: **Transposition**

Adjusts the playback pitch in semitone increments.
While holding the [R3] button slide your finger vertically over the matrix to move the lit horizontal line to the desired pitch.

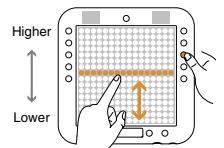

R4 + LED Buttons: **Changing the Layer Volume**

Displays the individual volume settings of all 16 layers, and allows the volume of each layer to be adjusted as required to create the ideal "mix" between layers.
Each row of LED buttons corresponds to a layer, beginning with layer 01 at the bottom row. While holding the [R4] button slide your finger horizontally over the row corresponding to the layer you want to adjust to set the volume as required. Each LED button row corresponds to a layer (01—16 from bottom to top), and the horizontal axis corresponds to volume level with volume increasing towards the right (the leftmost setting corresponds to "0" volume).

- You can also use the jog dial to set the overall (Master) volume (the Master volume setting will appear in the LCD display) (→ page 07).

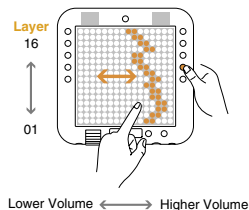

R5 + LED Buttons: **Switching Blocks**

Switches to a different block.
While holding the [R5] button slide your finger horizontally over the matrix to move the lit vertical line to the desired block.
Moving the line to the leftmost column selects block 01, the next column to the right is block 02, then block 03, and so on up to block 16.

- You can copy the contents of the current block to another block (→ page 17).

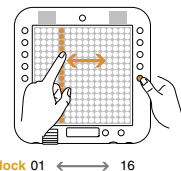

Layers

TENORI-ON layers can be thought of as “performance parts” or “recording tracks.” The TENORI-ON has a total of 16 layers. Separate notes and voices can be assigned to each layer, and all layers can be played together in synchronization.

The 16 layers are divided into six performance mode groups as shown in the illustration below. The six modes have different note entry methods and operation. Up to 16 layers created using different modes can be combined for rich, complex musical expression.

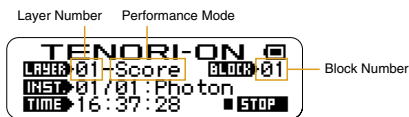

- When you switch between layers or blocks, the current layer number, performance mode, and block number will appear in the LCD display.

Blocks

One complete set of 16 layers is called a “block.”

The TENORI-ON can store up to 16 programmed blocks (16-layer groups) in memory, and you can switch from block to block instantly during performance.

You could, for example, create a musical composition in one block, then copy that composition to another block and edit it to create a variation of the original composition. Or you can load a number of previously-created compositions into separate blocks from an SD Memory Card and switch between them to create variation during playback.

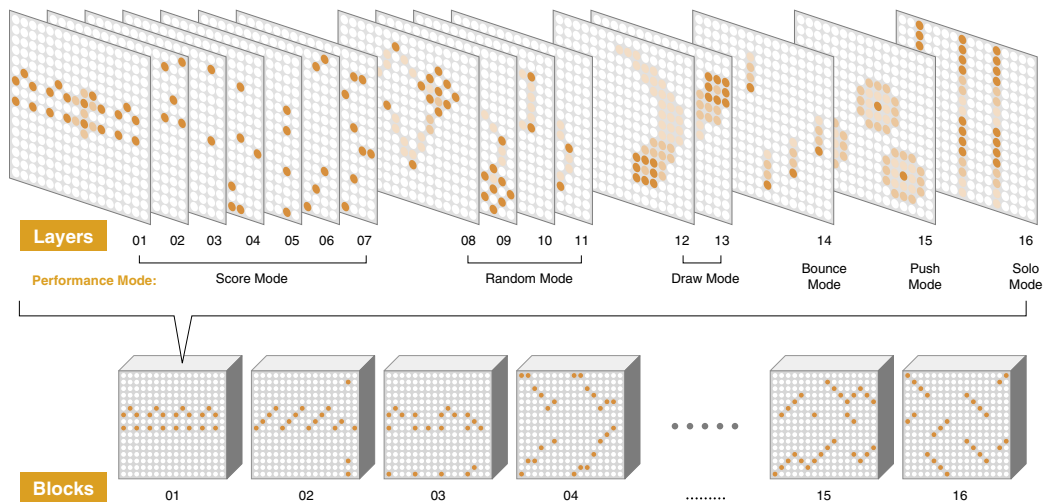

Layers and the Performance Modes

The six performance modes are assigned to the 16 layers as shown in the illustration below.

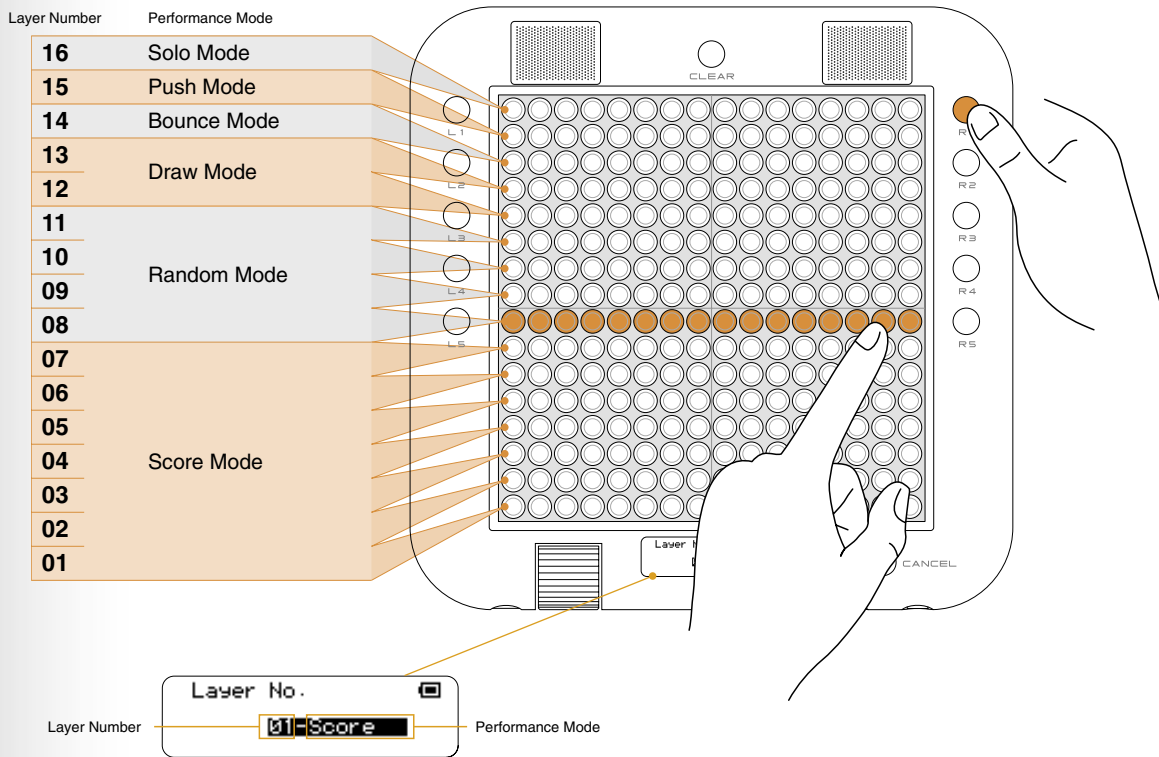

- When you switch layers the new layer and performance mode will appear in the LCD display.

For example, if you press any LED button in the eighth row from the bottom (any button in this row will do) while holding the [R1] function button as shown in the illustration, you will select the first Random Mode layer.

Random Mode Performance

If you press an LED button long enough to enter an active note in the Random Mode, the active note will play back repeatedly. If you then enter a few more active notes, the lights will “travel” from note to note, in the order entered, and the active notes will sound when the traveling light passes over them. The Random Mode thus produces a totally different type of loop from the Score Mode.

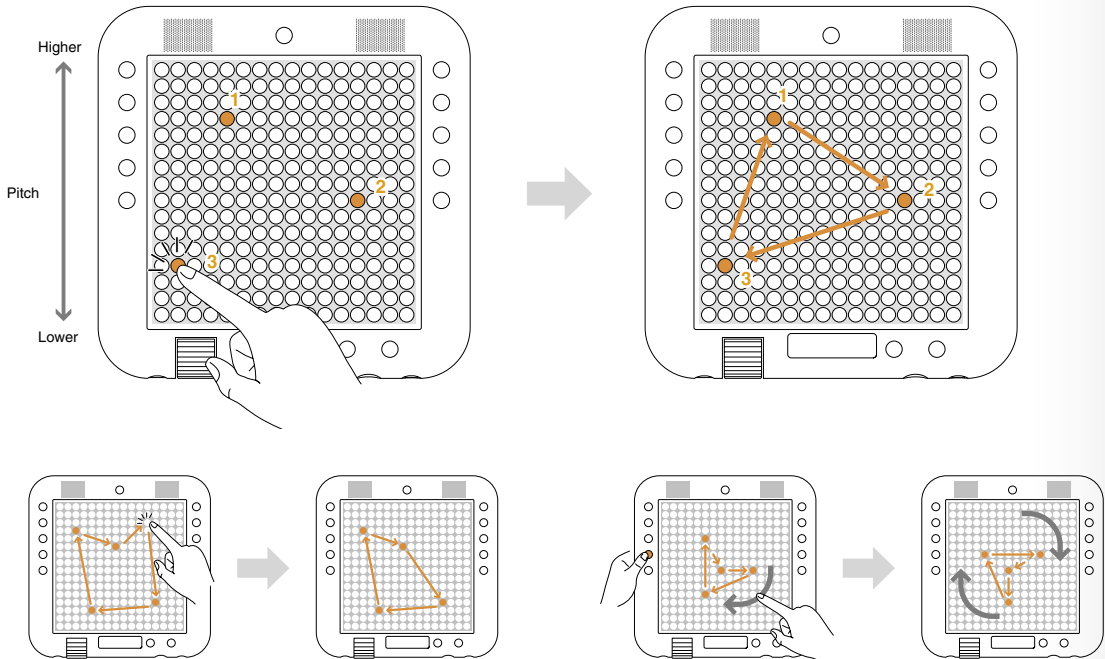

Hold the [L4] button.

Active notes can be individually deactivated by pressing and holding the corresponding LED button.

You can even spin loop-shapes you create in the Random Mode by holding the [L4] button and running a finger around the matrix in the direction and at the speed of the desired spin. The pitches of the notes will change accordingly as the shape spins, producing loop sound effects. To stop rotation, press and hold the LED button or press the same LED button twice while holding the [L4] button.

Draw Mode Performance

In this mode you can press individual LED buttons or draw lines or curves on the matrix, and those actions will be played back and repeated. You can keep adding to your “composition” during playback to build up thick sonic textures.

In the Draw Mode you cannot clear only a part of the performance. The entire layer can be cleared by pressing the [CLEAR] button.

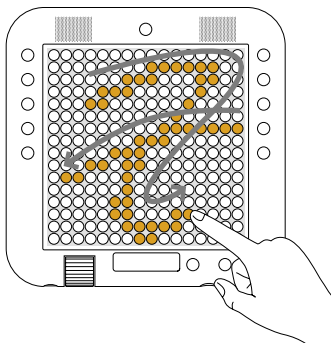
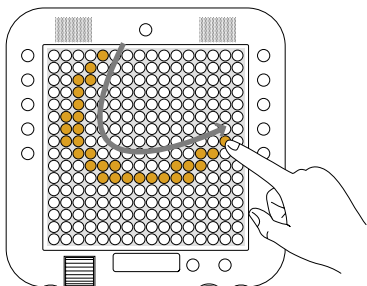

Bounce Mode Performance

Press an LED button and the light will “drop” from that button, bounce back from the bottom of the matrix, and repeat. The corresponding note will sound when the light bounces at the bottom row. The higher the entry point, the longer the interval between the sound. In the Bounce Mode the pitches are arranged horizontally, like a piano, with the lowest pitch on the left and the highest on the right.

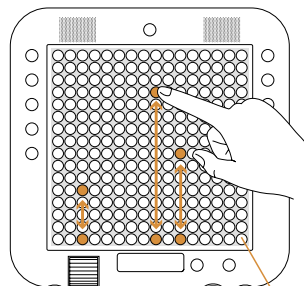

Press the lowest LED button to stop activity in that column.

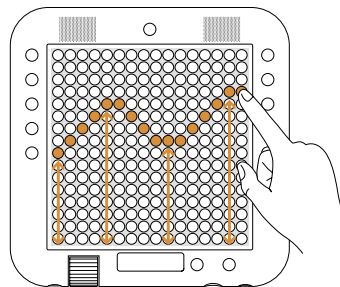

Bouncing can be individually stopped in any column by simply pressing the lowest LED button in that column.

Push Mode Performance

In this mode if you press and hold an LED button the sound of the corresponding note will begin to change gradually while the flashing surrounding that button gets brighter and wider. If the button is held briefly the note and flashing will stop when you release it, but if you hold the button for longer the note and flashing will continue even after the button is released.

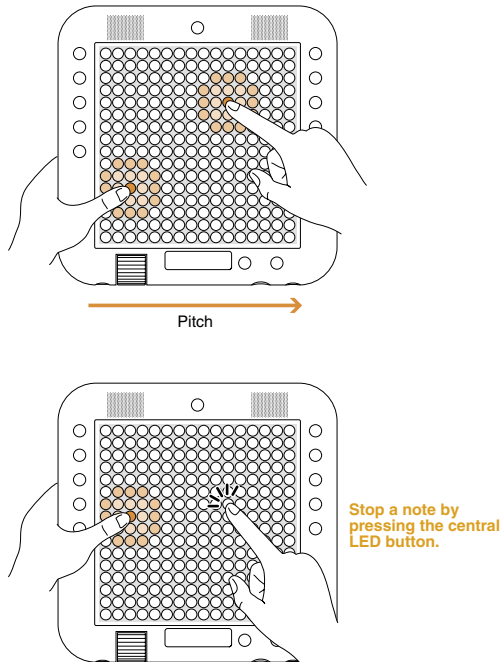

*Some voices will decay and stop even if a note is held, and some voices may not exhibit significant variation. The best voices to use in the Push Mode are those that sustain continuously.

Solo Mode Performance

Press an LED button and the corresponding note will repeat until the button is released. In the Solo Mode the pitches are arranged horizontally, like a piano. You can change the interval between repeats by pressing or sliding your finger to a lower (longer) or higher (shorter) LED button in the column. If you press the lowest LED button in a column the note will sound once without any repeats.

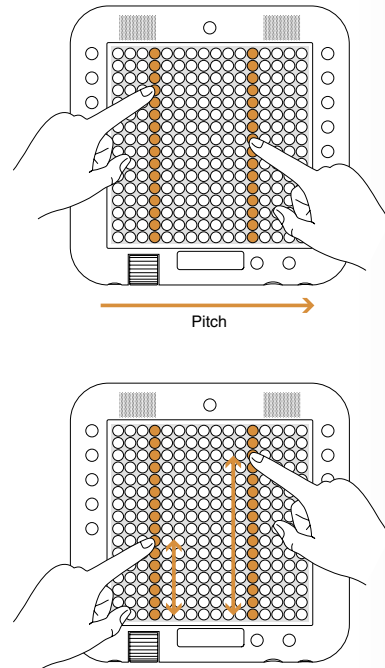

*If you turn the Quantize function ON, note timing in the Solo Mode will be synchronized to the Score Mode, making it easy to play solos with rhythm matching that of a background playing in the Score Mode layers. Refer to "Quantize" in the TENORI-ON Manual on the supplied CD-ROM.

Some Ideas for Using Blocks

You can leave the current composition in memory while copying it to other blocks where it can be edited to create variations that you can switch between at any time. You could also create totally different compositions in different blocks, and then switch between them in real time for interesting, varied performances.

Switching Between Blocks

You can switch between blocks simply by holding the [R5] function button and pressing an LED button in the column corresponding to the block you want to switch to.

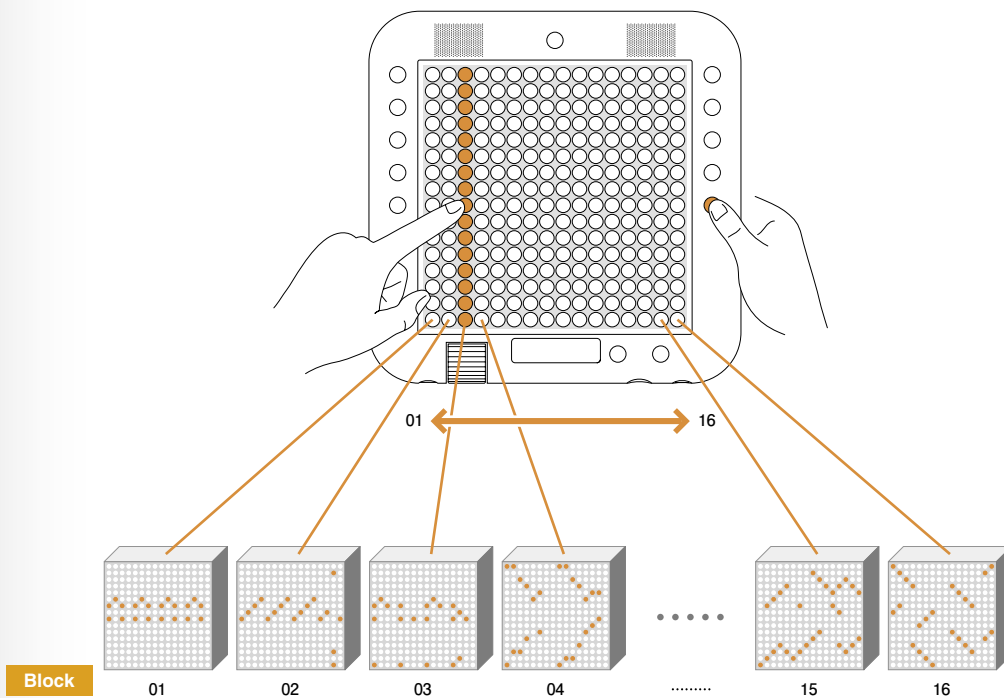

Copying from Block to Block

You can copy either a single layer to a different block, or all layers from the current block to another block.

• Copying via the LED Buttons

1. Select the layer or block you want to copy.
2. Press and hold the [R5] function button. The currently playing block will be displayed.

To Copy a Single Layer

While still holding the [R5] button press the lowest LED button in the lit column (the LEDs in the column will shine brighter), and then press an LED button in the column corresponding to the block you want to copy to. The current layer from the source block will be copied to the same layer in the destination block.

To Copy All Layers

While still holding the [R5] button press the lowest LED button in the lit column twice (the LEDs in the column will shine brighter each time the button is pressed), and then press an LED button in the column corresponding to the block you want to copy to. All layers from the source block will be copied to the destination block.

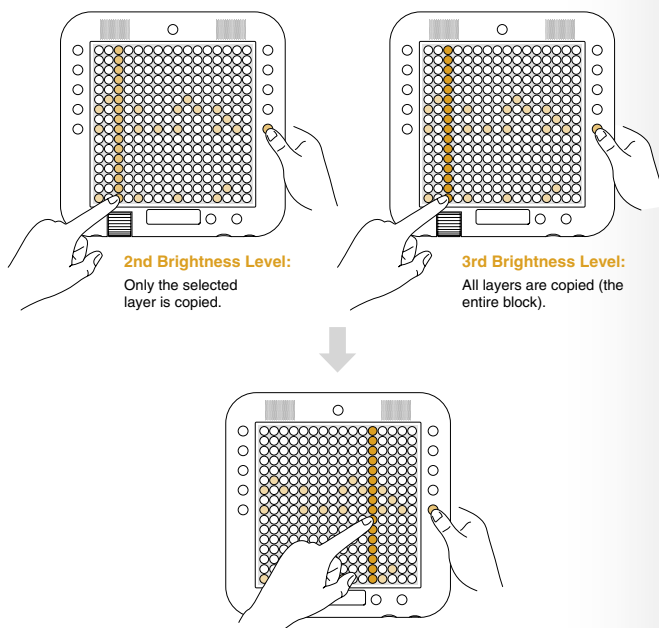

• Copying via the Menu

You can also copy either a single layer or all layers to a different block via the LCD Menu. Refer to "Edit Menu" in the TENORI-ON Manual on the supplied CD-ROM.

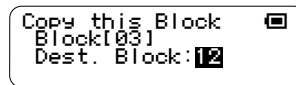

About the Menu

In addition to the wide range of control available via the function and LED buttons, a number of detailed settings can be made via the TENORI-ON menu, including tempo, clock display, SD Memory Card save/load, and many more.

Menu items in the LCD display can be selected and executed by using the jog dial and [OK]/[CANCEL] buttons.

Basic Menu Operation

Normally, status information is showing in the LCD display.

If you rotate the jog dial while the status information is showing the Main Menu will appear. Rotate the jog dial to select the desired menu item, and then press the [OK] button to go to the next display. By repeating these steps you can navigate to a desired function and execute or edit it as required.

To return to the Status display, press the [CANCEL] button as many times as necessary.

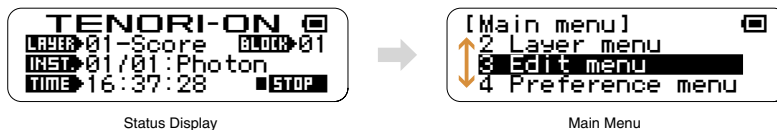
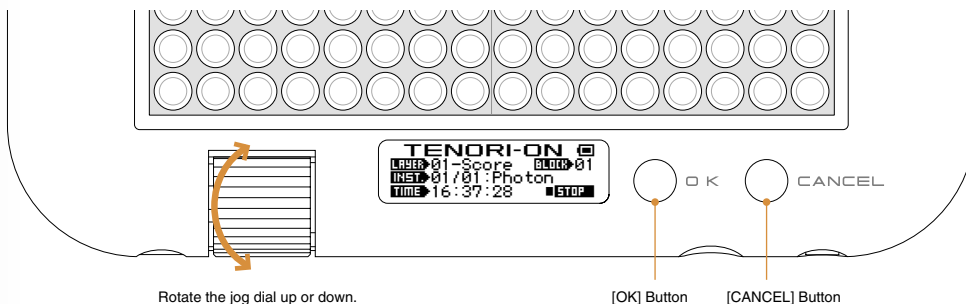

Menu Operation Example

• Changing the Light Animation

1. Rotate the jog dial to go to the Main Menu.
2. Continue rotating the jog dial to select "2 Layer menu," then press the [OK] button. The "Layer menu" will appear.

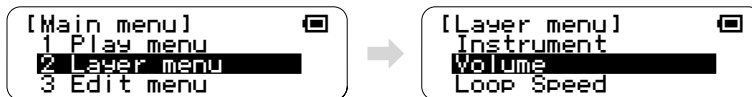

3. Use the jog dial to select "Animation" and press the [OK] button. The animation setup display will appear.

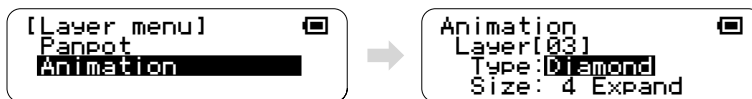

4. In the Animation display you can select the animation type, the maximum size of the animated flash, and whether the flash expands outward or shrinks inward. The current settings appear in the Animation display.

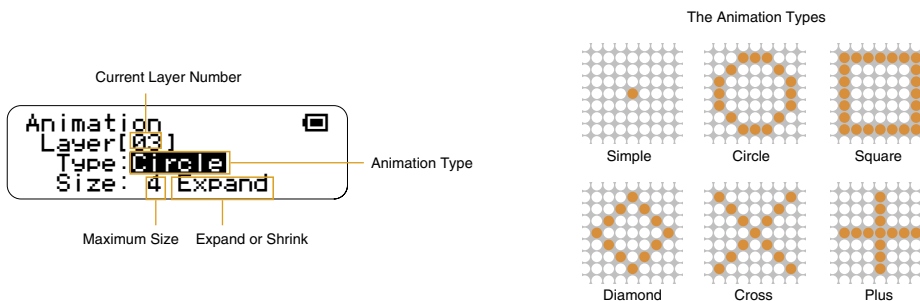

5. Rotate the jog dial to edit the highlighted parameter in the display. Once the current parameter is set as required, press the [OK] button to go to the next parameter. Once again, use the jog dial to edit the parameter, and then press the [OK] button. When you press the [OK] button after editing the last parameter in the display, the edits will be applied and the display will revert to the menu.

Play menu

Parameters that apply to all layers and blocks.

- Hardware Volume** Sets the hardware volume.
- Master Tempo** Sets the master tempo.
- Master Scale** Sets the master scale.
- Master Transpose** Sets transposition.
- Master Loop Speed** Sets the loop speed (beat duration) for all layers.
- Master Loop Point** Sets the loop range for all layers.
- Reset Loop Timing** Resets the playback position to the beginning of the loop.
- Mute** Mutes sound output.

Layer menu

Parameters that apply to the currently selected layer.

- Instrument** Selects the voice.
- Volume** Sets the layer volume.
- Loop Speed** Sets the loop speed.
- Sound Length** Sets the gate time.
- Panpot** Sets the stereo position of the sound
- Animation** Specifies the light animation.

Edit menu

Data edit functions such as copy, clear, and reset.

- Copy this Block** Copies the current block to another block.
- Clear this Block** Clears the active notes for the current blocks.
- Copy this Layer** Copies the layer.
- Clear this Layer** Clears the active notes for the current layer.
- Clear All Blocks** Clears the active notes from all blocks (all layers).
- Reset All Blocks** Resets all blocks (all layers).

Preference menu

Initial settings that apply to the entire instrument.

- Quantize** Synchronizes Solo Mode note timing with the Score Mode.
- Push Sensitivity** Sets LED-button press time for note activation.
- Master Tuning** Master tuning for the internal voices (MIDI tone generator).
- Local Control** Turns internal tone generator output ON or OFF.
- Synchronize** Synchronizes multiple TENORI-ON instruments.
- Loop Indicator** Displays or hides the loop indicator.

File menu

Data file save, load, rename and delete functions.

- Song** Song file operations.
- All Blocks** All Blocks file operations.
- Current Block** Current Block file operations.
- Current Layer** Current Layer file operations.
- All Settings** All Settings file operations.
- Samplings** Sampling file operations.

Effect menu

Reverb and chorus effect settings.

- Reverb Type** Sets the reverb effect type.
- Reverb Param** Sets the reverb effect depth.
- Chorus Type** Sets the chorus effect type.
- Chorus Param** Sets the chorus effect depth.

Interior menu

Settings not related to performance (clock, song playback).

- Interior START** Begins operation of the specified Interior Mode.
- Interior Type** Selects the type of Interior Mode operation.
- Saver Type** Selects the type of saver operation: Power Save Mode or Interior Mode.
- Saver Time** Sets the amount of time that must elapse before saver operation begins.
- Time Signal ON/OFF** Determines whether the time signal will be played or not.
- Alarm ON/OFF** Determines whether the alarm will sound or not.
- Set Alarm** Sets the alarm time.
- SaveAs Time Signal** Saves the data in the current block for use as the time signal.
- SaveAs Alarm** Saves the data in the current block for use as the alarm.
- Clock Adjust** Sets the current time and date.

System menu

Factory reset, SD Memory Card format, and more.

- SaveAs Default** Saves the current settings as the power-on defaults.
- SD Format** Formats an SD Memory Card.
- Owner Name** Enter the name of the TENORI-ON owner.
- Version Check** Display the TENORI-ON ROM version number.
- Factory Reset** TENORI-ON system reset.

Recording menu

Song recording and song file save.

- Recording** Song record and save.

● Refer to the TENORI-ON Manual on the supplied CD-ROM for menu details.

Prepare an SD Memory Card

An SD Memory Card is necessary for song recording. Purchase an SD Memory Card (2 gigabyte capacity or less), and format the card in the TENORI-ON memory card slot by selecting the "SD Format" function in the "System menu".



About Recording and Song Files

Performance operations carried out on the TENORI-ON can be recorded in real time and saved to an SD Memory Card as a Song File.

Song Files contain all operations carried out from the time recording is begun until it is ended: LED button operations, functions button operations, and [CLEAR] button operations are all recorded in real time. A recorded Song File can then be loaded into the TENORI-ON and played back, precisely reproducing the entire performance as it occurred.

Recording Procedure

1. Insert an SD Memory Card that has been properly formatted by the TENORI-ON into the card slot until it clicks firmly into place.
2. Use the jog dial to select "Main menu" → "Recording menu", and then press the [OK] button.



3. Press the [OK] button to begin recording. During recording the current settings and elapsed recording time will appear in the LCD display.



Elapsed Recording Time

- * The menus cannot be accessed during recording.
 - * The maximum recording time will depend on the performance being recorded.
4. When the performance is finished, press the [OK] button to stop recording. A display that will allow the recorded performance to be saved as a Song File to the SD Memory Card will appear.

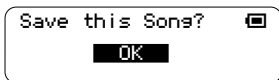

Saving the Song File

5. Press the [OK] button and the Song File name entry display will appear.

- * Press the [CANCEL] button if you do not want to save the Song File.
- * A default file name will be automatically assigned. You can use the default file name, or enter a new one. Song File names can be up to 16 characters long.

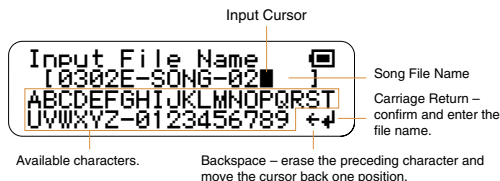



6. When the file name has been entered, select the "↵" symbol at the bottom of the display and press the [OK] button.
7. "Saving ..." will appear on the display while the file is being saved, and then the "Recording menu" will reappear.



To prevent file corruption and loss of data never turn the power off or remove the SD Memory Card while "Saving ..." is showing on the display. Press the [OK] or [CANCEL] button to cancel the file save operation at any time.

Song Playback

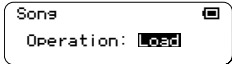
Load a Song File into the TENORI-ON and play it back.

1. Insert the SD Memory Card containing the saved Song File into the TENORI-ON card slot until it clicks firmly into place.
2. Use the jog dial and [OK] button to select "Main Menu" → "File menu" → "Song", and then press the [OK] button.
 
3. Rotate the jog dial to select "Operation: Load," and then press the [OK] button.
4. If there is more than one song on the SD Memory Card, use the jog dial to select the Song File you want to load and play, and then press the [OK] button to load the file.
 
5. When the load operation is complete playback will begin.

- * Song files can be attached to email messages and shared with other TENORI-ON users.

Using Original Samples

Sound files that you have recorded using your computer or downloaded can be loaded into the TENORI-ON user voice area (voice numbers <01/16,> <02/16,> and <03/16,>) and played in the same way as the internal voices, as described below. Refer to "File menu" in the TENORI-ON Manual on the supplied CD-ROM for more details.

WAVE or AIFF format audio files (sample files) can be loaded into the TENORI-ON user voice area (voice numbers <01/16,> <02/16,> and <03/16,>) and played in the same way as the internal voices. Each user voice can contain separate sound files that can be independently assigned to 16 LED buttons. (A maximum of 48 sound files can be used.)

Using the TENORI-ON User Voice Manager

The TENORI-ON User Voice Manager software provided on the supplied CD-ROM can be used to assign sound files to [LOAD] buttons ①—⑯ and save the result as a User Voice File. Sound files assigned to user voices can be up to 0.97 seconds long. User Voice Files created in this way can be transferred to the TENORI-ON via an SD Memory Card.

- Unlike the internal MIDI tone generator, octave, transpose, and scale settings cannot be used with user voices.
- User voices are retained in memory even if the TENORI-ON power is turned off.
- To play a song that uses user voices on another TENORI-ON, the appropriate user voices must be loaded in advance.

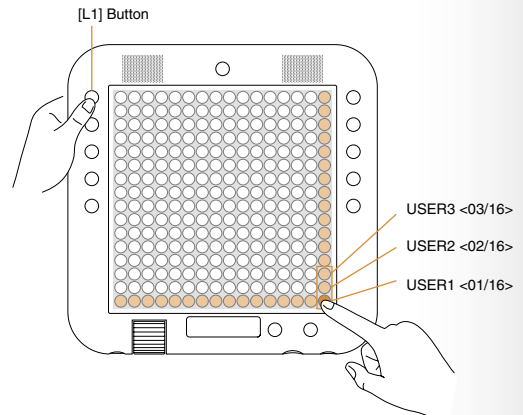
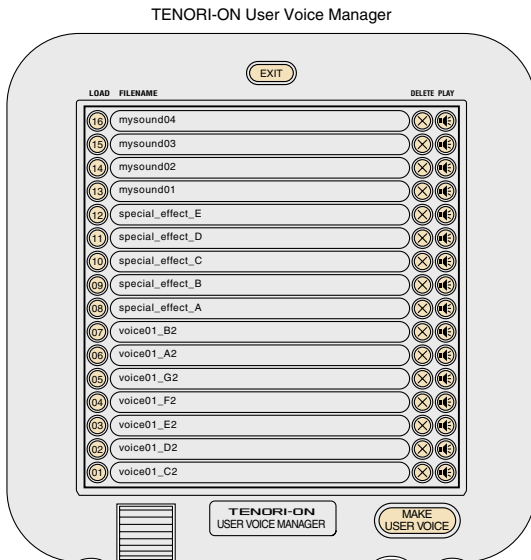

The Interior Mode

The Interior Mode allows the TENORI-ON to be used as a piece of interior decor. For example, you can set up the TENORI-ON to function as a clock that plays a composition you have created as an alarm. Or you could configure the TENORI-ON so that if it isn't operated for a certain length of time it will automatically begin playing a Song File from an SD Memory Card.

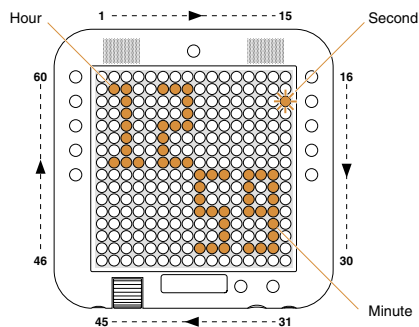

“Interior menu” Settings

The “Interior menu” provides access to settings that determine what the TENORI-ON does when it is not being used for performance.

- **Interior START** Begins operation of the specified Interior Mode.
- **Interior Type** Selects the type of Interior Mode operation.
- **Saver Type** Selects the type of saver operation: Power Save Mode or Interior Mode. You can exit from the Saver mode by pressing an LED button or operating any other control.
- **Saver Time** Sets the amount of time that must elapse before saver operation begins.
- **Time Signal ON/OFF** Determines whether the time signal will be played (ON) or not (OFF).
- **Alarm ON/OFF** Determines whether the alarm will sound (ON) or not (OFF).
- **Set Alarm** Sets the alarm time.
- **SaveAs Time Signal** Saves the data in the current block for use as the time signal.
- **Save As Alarm** Saves the data in the current block for use as the alarm.
- **Clock Adjust** Sets the current time and date.

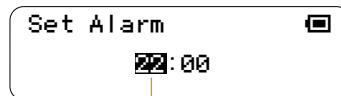
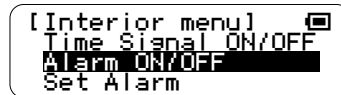

Set using the jog dial and [OK] button.

Interior Types

Song (DEMO) Plays the pre-programmed TENORI-ON demo song.

Song (SD) Randomly plays Song Files from an SD Memory Card.

Clock Displays the time on the TENORI-ON matrix.

Clock+Song (DEMO) Displays the time on the TENORI-ON matrix while playing the pre-programmed TENORI-ON demo song. The demo song light animation appears on the matrix in addition to the time.

Clock+Song (SD) Displays the time on the TENORI-ON matrix while randomly playing Song Files from an SD Memory Card. The song light animation appears on the matrix in addition to the time.

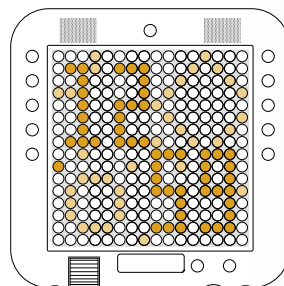
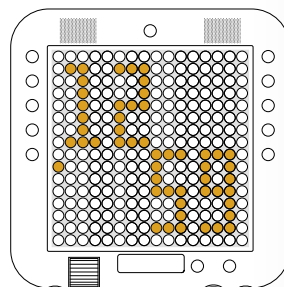
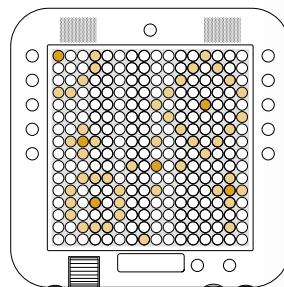

TENORI-ON

The interface features a central 16x16 grid of circles. Above the grid is a 'CLEAR' button. To the left of the grid are five buttons labeled L1 through L5, corresponding to 'Instrument', 'Sound Length', 'Octave', 'Loop Point', and 'Loop Speed'. To the right are five buttons labeled R1 through R5, corresponding to 'Layer', 'Tempo', 'Transpose', 'Volume', and 'Block'. Below the grid is a 'Mode:' field, 'OK' and 'CANCEL' buttons, and a speaker icon. At the bottom right, there are 'Panpot' and 'Scale' buttons.

Score No.	Date:	User Voice File 3:
Song File Name:	Time:	User Voice File 2:
Owner's Name:	User Voice File 1:	

SCORE SHEET

● Sequencer

Note Resolution	♩ = 96 clocks
Gate Time	10 ms—9990 ms
Octaves	-5—+5
Tempo (BPM)	40—240
Scales	9 types
Transpose	-7—+8
Performance Modes	6 types: Score, Random, Draw, Bounce, Push, Solo
Other Functions	Clock, power-save, synchronized performance with two TENORI-ON instruments, recording, TENORI-ON song playback
Maximum Active Notes	Push Mode: 64 Random Mode: 64 points Draw Mode: 64 points

● Tone Generator

Tone Generator Type	AWM2
Maximum Polyphony	32 notes
Preset Voices	253 (239 normal, 14 drum kit)
Effects	2 processors Reverb: 10 types Chorus: 5 types
Sampling	3 voices (Raw audio with a maximum length of 0.97 sec., up to 16 samples per voice) *Using the supplied TENORI-ON User Voice Manager software.

● Card

Save	Song/Block/Layer/Setting/Sampling
Load	Song/Block/Layer/Setting/Sampling
Rename	Song/Block/Layer/Setting/Sampling
Delete	Song/Block/Layer/Setting/Sampling
Format	

● Controller & Display

LED Buttons	256
Rear LED Display Points	256 (No function)
Function Buttons	10 (L1—L5, R1—R5)
CLEAR, OK, CANCEL Buttons	1 each
Jog Dial	
Display	122 x 32 dot graphic LCD device (yellow-green backlight), 20 characters x 4 lines, monochrome

● Sound

Stereo Speakers	1-watt output power
------------------------------	---------------------

● Connectors

Line Out/Phones	Stereo mini phone jack x 1
Mini DIN	MIDI IN: for synchronized performance using two TENORI-ON instruments MIDI OUT: for external device control
Card Slot	SD Memory Card compatible
DC In	Connector for PA-3C, PA-130 or equivalent Yamaha AC adaptor

● Power Supply

6 “AA” alkaline batteries	
AC Adaptor	PA-3C, PA-130 or equivalent Yamaha AC adaptor

● Dimensions & Weight

Dimensions	205 x 205 x 32 mm (8-1/16" x 8-1/16" x 1-1/4")
Weight	Approx. 700g (1 lbs. 9 oz.) (without batteries)

● Supplied Accessories

Mini DIN cable, CD-ROM x 1, AC Adaptor (PA-3C, PA-130 or equivalent Yamaha AC adaptor), Quick Guide, Installation Guide, Precautions

● Specifications and descriptions in this owner's manual are for information purposes only. Yamaha Corp. reserves the right to change or modify products or specifications at any time without prior notice. Since specifications, equipment or options may not be the same in every locale, please check with your Yamaha dealer.



<http://www.global.yamaha.com/tenori-on>

Yamaha Home Keyboards Home Page (English only)
<http://music.yamaha.com/homekeyboard>

Yamaha Manual Library
<http://www.yamaha.co.jp/manual/>

**U.R.G., Pro Audio & Digital Musical Instrument Division,
© 2007 Yamaha Corporation**

**WK01980 701MWCP0.0-00A0
Printed in Japan**