



DIGITAL PRODUCTION CONSOLE **DM 2000**  
*Version 2*  
**Owner's Manual**

Keep This Manual For Future Reference.

## FCC INFORMATION (U.S.A.)

1. **IMPORTANT NOTICE: DO NOT MODIFY THIS UNIT!** This product, when installed as indicated in the instructions contained in this manual, meets FCC requirements. Modifications not expressly approved by Yamaha may void your authority, granted by the FCC, to use the product.
2. **IMPORTANT:** When connecting this product to accessories and/or another product use only high quality shielded cables. Cable/s supplied with this product **MUST** be used. Follow all installation instructions. Failure to follow instructions could void your FCC authorization to use this product in the USA.
3. **NOTE:** This product has been tested and found to comply with the requirements listed in FCC Regulations, Part 15 for Class "B" digital devices. Compliance with these requirements provides a reasonable level of assurance that your use of this product in a residential environment will not result in harmful interference with other electronic devices. This equipment generates/uses radio frequencies and, if not installed and used according to the instructions found in the users manual, may cause interference harmful to the operation of other electronic devices. Compliance with FCC regulations does not guarantee that interference will not occur in all installations. If this product is found to be the source of interference, which can be determined by turning the unit "OFF" and "ON", please try to eliminate the problem by using one of the following measures: Relocate either this product or the device that is being affected by the interference. Utilize power outlets that are on different branch (circuit breaker or fuse) circuits or install AC line filter/s. In the case of radio or TV interference, relocate/reorient the antenna. If the antenna lead-in is 300 ohm ribbon lead, change the lead-in to coaxial type cable. If these corrective measures do not produce satisfactory results, please contact the local retailer authorized to distribute this type of product. If you can not locate the appropriate retailer, please contact Yamaha Corporation of America, Electronic Service Division, 6600 Orangethorpe Ave, Buena Park, CA 90620

The above statements apply **ONLY** to those products distributed by Yamaha Corporation of America or its subsidiaries.

**WARNING: THIS APPARATUS MUST BE EARTHED**

### IMPORTANT

THE WIRES IN THIS MAINS LEAD ARE COLOURED IN ACCORDANCE WITH THE FOLLOWING CODE:

GREEN-AND-YELLOW :	EARTH
BLUE :	NEUTRAL
BROWN :	LIVE

As the colours of the wires in the mains lead of this apparatus may not correspond with the coloured markings identifying the terminals in your plug, proceed as follows:

The wire which is coloured GREEN and YELLOW must be connected to the terminal in the plug which is marked by the letter E or by the safety earth symbol  $\perp$  or coloured GREEN and YELLOW.

The wire which is coloured BLUE must be connected to the terminal which is marked with the letter N or coloured BLACK.

The wire which is coloured BROWN must be connected to the terminal which is marked with the letter L or coloured RED.

\* This applies only to products distributed by YAMAHA KEMBLE MUSIC (U.K.) LTD.

**ADVARSEL!**

Lithiumbatteri—Eksplodingsfare ved fejlagtig håndtering. Udskiftning må kun ske med batteri af samme fabrikat og type. Levér det brugte batteri tilbage til leverandoren.

**VARNING**

Explosionsfara vid felaktigt batteribyte. Använd samma batterityp eller en ekvivalent typ som rekommenderas av apparattillverkaren.

Kassera använt batteri enligt fabrikantens instruktion.

**VAROITUS**

Paristo voi räjähtää, jos se on virheellisesti asennettu. Vaihda paristo ainoastaan laitevalmistajan suosittelemaan tyyppiin. Hävitä käytetty paristo valmistajan ohjeiden mukaisesti.

## NEDERLAND / THE NETHERLANDS

- Dit apparaat bevat een lithium batterij voor geheugen back-up.
- This apparatus contains a lithium battery for memory back-up.
- Raadpleeg uw leverancier over de verwijdering van de batterij op het moment dat u het apparaat aan het einde van de levensduur of gelieve dan contact op te nemen met de vertegenwoordiging van Yamaha in uw land.
- For the removal of the battery at the moment of the disposal at the end of life please consult your retailer or Yamaha representative office in your country.
- Gooi de batterij niet weg, maar lever hem in als KCA.
- Do not throw away the battery. Instead, hand it in as small chemical waste.

(lithium disposal)

This product contains a high intensity lamp that contains a small amount of mercury. Disposal of this material may be regulated due to environmental considerations. For disposal information in the United States, refer to the Electronic Industries Alliance web site: [www.eiae.org](http://www.eiae.org)

\* This applies only to products distributed by YAMAHA CORPORATION OF AMERICA.

(mercury)

---

# Important Information

---

## Warnings

- Connect this unit's power cord only to an AC outlet of the type stated in this Owner's Manual or as marked on the unit. Failure to do so is a fire and electrical shock hazard.
- Be sure to connect to an appropriate outlet with a protective grounding connection. Improper grounding can result in electrical shock.
- Do not allow water to enter this unit or allow the unit to become wet. Fire or electrical shock may result.
- Do not place heavy objects, including this unit, on top of the power cord. A damaged power cord is a fire and electrical shock hazard. In particular, be careful not to place heavy objects on a power cord covered by a carpet.
- Do not place a container with liquid or small metal objects on top of this unit. Liquid or metal objects inside this unit are a fire and electrical shock hazard.
- This unit is equipped with a dedicated ground connection to prevent electrical shock. Before connecting the power plug to an AC outlet, be sure to ground the unit. If the power cord has a three-pin plug, it will provide sufficient grounding so long as the AC outlet is grounded correctly.
- Do not scratch, bend, twist, pull, or heat the power cord. A damaged power cord is a fire and electrical shock hazard.
- Do not remove the unit's cover. You could receive an electrical shock. If you think internal inspection, maintenance, or repair is necessary, contact your dealer.
- Do not modify the unit. Doing so is a fire and electrical shock hazard.
- If lightning begins to occur, turn off the power switch of the unit as soon as possible, and unplug the power cable plug from the electrical outlet.
- If there is a possibility of lightning, do not touch the power cable plug if it is still connected. Doing so may be an electrical shock hazard.
- Use only the included power cord for this unit. Using other types may be a fire and electrical shock hazard.
- The DM2000 has six rear-panel slots for installing mini-YGDAI cards. For technical reasons, certain card combinations are not supported. Before installing any cards, check the Yamaha web site to if your card is compatible. Installing cards that are not endorsed by Yamaha may cause electrical shock, fire, or damage to the unit.
- If the power cord is damaged (i.e., cut or a bare wire is exposed), ask your dealer for a replacement. Using the unit with a damaged power cord is a fire and electrical shock hazard.
- If you notice any abnormality, such as smoke, odor, or noise, or if a foreign object or liquid gets inside the unit, turn it off immediately. Remove the power cord from the AC outlet. Consult your dealer for repair. Using the unit in this condition is a fire and electrical shock hazard.
- Should this unit be dropped or the cabinet be damaged, turn the power switch off, remove the power plug from the AC outlet, and contact your dealer. If you continue using the unit without heeding this instruction, fire or electrical shock may result.

## Cautions

- Keep this unit away from the following locations:
  - Locations exposed to oil splashes or steam, such as near cooking stoves, humidifiers, etc.
  - Unstable surfaces, such as a wobbly table or slope.
  - Locations exposed to excessive heat, such as inside a car with all the windows closed, or places that receive direct sunlight.
  - Locations subject to excessive humidity or dust accumulation.

- Hold the power cord plug when disconnecting it from an AC outlet. Never pull the cord. A damaged power cord is a potential fire and electrical shock hazard.
- Do not touch the power plug with wet hands. Doing so is a potential electrical shock hazard.
- This unit has ventilation holes along the front underside and at the rear to prevent the internal temperature from rising too high. Do not block them. Blocked ventilation holes are a fire hazard. In particular, do not operate the unit while it's on its side, is upside down, or while it's covered with a cloth or dust sheet.
- If you are using the optional MB2000 Peak Meter Bridge, do not hold only the MB2000 when you move the entire unit. Otherwise, the meter angle may be deformed or damaged, the main unit may malfunction, or you may be injured if the unit falls.
- This unit is heavy. Use two or more people to carry it.
- When you transport or move the DM2000 with the MB2000 attached, do not permit impact or stress on the cable connector that connects the MB2000 to the DM2000. Otherwise, malfunction may occur.
- To relocate the unit, turn the power switch off, remove the power plug from the AC outlet, and remove all connecting cables. Damaged cables may cause fire or electrical shock.
- When setting up the product, make sure that the AC outlet you are using is easily accessible. If some trouble or malfunction occurs, immediately turn off the power switch and disconnect the plug from the outlet. Even when the power switch is turned off, electricity is still flowing to the product at the minimum level. When you are not using the product for a long time, make sure to unplug the power cord from the wall AC outlet.
- If you know you will not use this unit for a long period of time, such as when going on vacation, remove the power plug from the AC outlet. Leaving it connected is a potential fire hazard.
- The inside of the unit should be cleaned periodically. Dust accumulation inside the unit may cause malfunction and is a potential fire hazard. Consult your dealer for information about cleaning.
- To prevent electrical shock when cleaning the unit, remove the power plug from the AC outlet.
- Do not apply oil, grease, or contact cleaner to the faders. Doing so may cause problems with electrical contact or fader motion.
- Do not use the headphones for a long period of time at a high or uncomfortable volume level, since this can cause permanent hearing loss. If you experience any hearing loss or ringing in the ears, consult a physician.

## Operating Notes

- XLR-type connectors are wired as follows: pin 1–ground, pin 2–hot (+), and pin 3–cold (–).
- Insert TRS phone jacks are wired as follows: sleeve–ground, tip–send, and ring–return.
- The performance of components with moving contacts, such switches, rotary controls, faders, and connectors, deteriorates over time. The rate of deterioration depends on the operating environment and is unavoidable. Consult your dealer about replacing defective components.
- Using a mobile telephone near this unit may induce noise. If noise occurs, use the telephone away from the unit.
- If the message “WARNING Low Battery!” appears when you turn on this unit, contact your dealer as soon as possible about replacing the internal data backup battery. The unit will still operate correctly, but data other than the presets will be lost.
- Before replacing the batteries, back up your data to a memory card, or another unit by using MIDI Bulk Dump.
- The digital circuits of this unit may induce a slight noise into nearby radios and TVs. If noise occurs, relocate the affected equipment.
- When connecting D-sub cables, be sure to tighten the screws on both sides of the connector securely. To disconnect the cable, loosen the screws completely, then remove the cable by holding the connector part. Do not remove the plug by pulling the cable while the screws are still attached. Otherwise, the connector may be damaged, leading to malfunction.

- When you change the wordclock settings on any device in your digital audio system, some devices may output noise, so turn down your power amps beforehand, otherwise your speakers may be damaged.

## SmartMedia Handling Precautions

- The CARD slot is for use with SmartMedia only. Never attempt to insert any other type of storage media.
- Use only SmartMedia of the type specified in this *Owner's Manual*.
- Store SmartMedia in a place free from extreme temperatures, humidity, dust, and dirt.
- Always store SmartMedia in its original case.
- Write only on the designated area.
- When handling SmartMedia, be careful not to touch the gold contacts. Fingerprints, smudges, scratches, or dirt can affect performance.
- Fingerprints and dust should be removed by wiping gently using a soft, dry cloth. Do not use benzene, thinner, cleaning detergent, or a chemical cloth.
- If SmartMedia is stored in a cold place (e.g., overnight in a car), and then moved to a warmer environment, or if the temperature rises sharply, condensation may form on the surface, which may affect performance. In this case, the SmartMedia should be allowed to acclimatize for about one hour before use.
- Insert SmartMedia carefully into the CARD slot, with the gold contacts facing upward.
- Do not bend or twist SmartMedia.
- Do not under any circumstances attempt to use SmartMedia that is cracked or warped. Doing so may seriously damage the CARD slot.
- Do not remove SmartMedia while saving or loading data. Doing so may cause data loss.
- Data stored on SmartMedia can be protected against inadvertent overwriting by attaching a write-protect sticker (supplied with SmartMedia).

## Interference

The DM2000 uses high-frequency digital circuits that may cause interference on radio and television equipment located nearby. If interference is a problem, relocate the affected equipment. Using a mobile telephone near the unit may induce noise. In this case use the telephone away from the unit.

## DM2000 Exclusion of Certain Responsibility

Manufacturer, importer, or dealer shall not be liable for any incidental damages including personal injury or any other damages caused by improper use or operation of the DM2000.

## Trademarks

ADAT MultiChannel Optical Digital Interface is a trademark and ADAT and Alesis are registered trademarks of Alesis Corporation. Apogee is a trademark of Apogee Electronics, Inc. Apple, Mac, and Power Macintosh are registered trademarks and Mac OS is a trademark of Apple Corporation, Inc. HUI is a trademark of Mackie Designs, Inc. Intel and Pentium are registered trademarks of Intel Corporation. Nuendo is a registered trademark of Steinberg Media Technologies AG. Pro Tools is a trademark or registered trademark of Digidesign and/or Avid Technology, Inc. SmartMedia is a trademark of Toshiba, Corp. Sony is a registered trademark of Sony Corporation, Inc. Tascam Digital Interface is a trademark and Tascam and Teac are registered trademarks of Teac Corporation. Microsoft and Windows are registered trademarks of Microsoft Corporation, Inc. Waves is a trademark of Waves, Inc. Yamaha is a trademark of Yamaha Corporation. Nuendo and Cubse SX are trademarks of Steinberg Media Technologies GmbH. All other trademarks are the property of their respective holders and are hereby acknowledged.

## Copyright

No part of the DM2000, its software, or this *Owner's Manual* may be reproduced or distributed in any form or by any means without the prior written authorization of Yamaha Corporation.

© 2003 Yamaha Corporation. All rights reserved.

## Yamaha Web Site

Further information about the DM2000, related products, and other Yamaha professional audio equipment is available on the Yamaha Professional Audio Web site at: <http://www.yamahaproaudio.com/>.

## Package Contents

- DM2000 Digital Production Console
- CD-ROM
- Power cord
- This manual
- Studio Manager Installation Guide

## Optional Extras

- MB2000 Peak Meter Bridge
- SP2000 Wooden Side Panels
- LA1800 Light Gooseneck
- mini YGDAI I/O cards

## About this Owner's Manual

This *Owner's Manual* covers the DM2000 Digital Production Console.

All the information you need in order to operate the DM2000 Digital Production Console is contained in this manual. Use the table of contents to familiarize yourself with the manual's organization and to locate tasks and topics, and use the index to locate specific information. Before diving in, it's recommend that you read the "Operating Basics" chapter, starting on page 51.

Each chapter of this manual discusses a specific section or function of the DM2000. The Input and Output Channels are explained in the following chapters: "Input Channels," "Bus Outs," "Aux Sends," "Matrix Sends," and "Stereo Out." Where possible, these chapters have been organized in order of signal flow, from input through to output.

Functions such as EQ and Delay are common to all channels. Rather than repeat the same information over and over, these functions are explained once in the "Common Channel Functions" chapter, which starts on page 127. The "Input Channels," "Bus Outs," "Aux Sends," "Matrix Sends," and "Stereo Out" chapters contain cross-references to the relevant sections of the "Common Channel Functions" chapter.

## Conventions Used in this Manual

The DM2000 features two types of button: physical buttons that you can press (e.g., ENTER and DISPLAY) and buttons that appear on the display pages. References to physical buttons are enclosed in square brackets, for example, "press the [ENTER] button." References to display page buttons are not emphasized, for example, "press the ENTER button."

Display pages can be selected by using the [DISPLAY] buttons or the Left Tab Scroll, Right Tab Scroll, and F1–4 buttons below the display. In order to simplify explanations, only the [DISPLAY] button method is mentioned in the procedures. See "Selecting Display Pages" on page 53 for details on all the ways in which pages can be selected.

---

## Installing the DM2000

The DM2000 should be placed on a strong and stable surface, somewhere that complies with the warnings and cautions listed in the previous sections.

## New Functions in DM2000 Version 2

The following functions have been added to the DM2000 as part of the upgrade of the firmware from version 1.2 to version 2.0.

### Control Surface

- When you operate the faders (for fader levels) or Encoders (for pan settings), the corresponding fader level or pan setting appears on the channel strip display.
- You can switch the indication on the channel strip display between channel name/ID and port name/ID. → page 276
- Encoder mode now features an assignable function, ALT LAYER, which enables you to control the channel level for all 48 channels without switching between layers. → page 61
- There are now 50 assignable Encoder mode parameters. → page 63

### Input Channels

- Surround Pan supports 6.1 Surround. → page 97
- You can change the bus assigned to each surround pan channel. → page 99
- The Fader Group Master function enables you to control the overall level of the Fader group channels simultaneously while maintaining the relative level balance of each channel. → page 92
- The Mute Group Master function enables you to mute all channels in a Mute group simultaneously. → page 90
- The on/off status of the Follow Pan button is reflected in the pan and Surround Pan settings. → page 93

### Aux Sends

- You can exclude channels from Aux Sends (Mix Minus). → page 117
- You can copy the channel fader positions to Aux Sends. → page 118
- You can set all Send levels to nominal simultaneously. → page 112
- If an Aux Send is set to pre-fader, you can set the Pre point before or after the [ON] button. → page 112

### Common Channel Functions

- Input and Output Channel Meter pages indicate the gain reduction being applied by the Gate and Compressor. → page 128
- You can select whether the Input Channel's Pan setting is used when the Input Channel Solo signal is set to Pre Fader. → page 143
- Raising the channel faders for soloed Channels from  $-\infty$  can unsolo the Channels. → page 143
- The AUX SELECT [AUX 1]–[AUX 12] buttons enable you to solo or unsolo Aux Sends. → page 143
- The Fader Group Master function enables you to control the overall level of the Fader group channels simultaneously while maintaining the relative level balance of each channel. → page 147
- The Mute Group Master function enables you to mute all channels in a Mute group simultaneously. → page 149

## Monitor

- The level of the Surround Monitor can be reset to 85dB SPL. → page 160
- A new parameter has been added to Bass Management on the Surround Monitor Setup page. → page 162
- Surround Monitor is also available when Surround mode is set to Stereo.
- You can simultaneously select BUS and ASSIGN1 or BUS and ASSIGN 2 for surround monitoring.
- You can select from Slot Channel 9 through Channel 16 as Surround Monitor signal sources.
- You can simultaneously select 2TRD, D2, D3, A1, or A2, and STEREO, ASSIGN1, or ASSIGN2 as Control Monitor signal sources.
- You can select the Talkback mic signal as the Studio Monitor source. → page 164

## Effects, Plug-ins and GEQ

- You can add optional Add-On Effects to the preset effects. → page 178
- The channel faders enable you to adjust the gain for each band in the graphic EQ. → page 184

## Scene Memory

- You can globally apply the Fade Time setting to all scenes. → page 189
- You can globally apply the Recall Safe setting to all scenes. → page 190
- Any channel or parameter settings in the current scene can be copied and pasted into other scenes. → page 191
- You can select more parameters for the Recall Safe function. → page 190

## Automix

- You can insert the current mix parameters in a region specified in the Automix data. → page 203
- Touching the faders can punch parameter values in and out if the corresponding OVERWRITE button is set to on. → page 194
- Some parameters related to timecode synchronization have been added. → page 278

## Remote Control

- The Joystick or the controls in the SELECTED CHANNEL section enable you to control Pro Tools Surround Pan settings.
- The USER DEFINED KEYS enable you to switch windows in the included Studio Manager application software.
- You can remotely control the Yamaha AD8HR A/D Converter.

## Other Functions

- A user-assignable layer enables you to assign Channels to Remote layer targets. → page 269
- You can also select General DAW (for DAW software that supports the Pro Tools protocol) or Cubase SX as the target for a Remote layer. → page 253
- Yamaha's proprietary Advanced DAW protocol has been added to Nuendo, Cubase SX, and General DAW. This enables you to control these devices using the DM2000's SELECTED CHANNEL section. (Controllable functions vary depending on the DAW software and version you are using.)
- You can now assign any of 214 functions to the USER DEFINED KEYS. → page 283
- You can assign the selected channels to a Fader or Mute group using the USER DEFINED KEYS. → page 283
- An Operation Lock function prevents unintentional edits and uses a password to restrict access to panel operation. → page 280



- The Oscillator can output sine wave signals with different frequencies to the L and R channels and odd and even buses. → page 279
- You can set the Auto Direct Out On check box so that if you change a channel's Direct Out destination, the channel Direct Out will automatically be enabled. → page 276
- You can set the Routing ST Pair Link check box so that the routing from paired Channels to the Stereo Bus is linked. → page 276

This product contains a battery that contains perchlorate material.  
Perchlorate Material—special handling may apply,  
See [www.dtsc.ca.gov/hazardouswaste/perchlorate](http://www.dtsc.ca.gov/hazardouswaste/perchlorate).

\* This applies only to products distributed by YAMAHA CORPORATION OF AMERICA. (Perchlorate)

**COMPLIANCE INFORMATION STATEMENT  
(DECLARATION OF CONFORMITY PROCEDURE)**

Responsible Party : Yamaha Corporation of America  
Address : 6600 Orangethorpe Ave., Buena Park, Calif. 90620  
Telephone : 714-522-9011  
Type of Equipment : Digital Production Console  
Model Name : DM2000

This device complies with Part 15 of the FCC Rules.  
Operation is subject to the following two conditions:  
1) this device may not cause harmful interference, and  
2) this device must accept any interference received including interference  
that may cause undesired operation.  
See user manual instructions if interference to radio reception is suspected.

\* This applies only to products distributed by  
YAMAHA CORPORATION OF AMERICA.

(FCC DoC)

---

# Contents

---

<b>1</b>	<b>Welcome</b>	<b>17</b>
<b>2</b>	<b>Control Surface &amp; Rear Panel</b>	<b>20</b>
	Control Surface	20
	Rear Panel	45
<b>3</b>	<b>Operating Basics</b>	<b>51</b>
	Connecting the Power Cord	51
	Turning On & Off the DM2000	51
	About the Display	52
	Selecting Display Pages	53
	Display History	53
	Display Page Controls	54
	Parameter Windows	54
	Confirmation Messages	54
	Title Edit Window	54
	Using a Keyboard	55
	Channel Strip Displays	55
	Selecting Layers	58
	Selecting Channels	59
	Selecting Fader Modes	60
	Selecting Encoder Modes	61
	Assigning Parameters to the ENCODER MODE Assign Buttons	62
<b>4</b>	<b>Analog I/O &amp; the AD Input Section</b>	<b>64</b>
	AD Input Section	64
	Stereo Out	65
	Control Room Monitor Outs	65
	Studio Monitor Outs	65
	Omni Outs	65
	2TR Analog INs	65
<b>5</b>	<b>Digital I/O &amp; Cascading</b>	<b>66</b>
	Wordclocks	66
	2TR Digital Outs	68
	2TR Digital Ins	69
	2TR In/Out Sampling Rate Conversion	69
	Slot I/O	70
	Dithering Digital Outputs	73
	Monitoring Digital Input Channel Status	73
	Cascading Consoles	74
<b>6</b>	<b>Input &amp; Output Patching</b>	<b>77</b>
	Input Patching	77
	Output Patching	79
	Naming Input & Output Ports	82
	Patch Select Window	83
	Patching with the Encoders	83

<b>7</b>	<b>Input Channels</b>	<b>84</b>
	Patching Input Channels	84
	Metering Input Channels	84
	Reversing the Signal Phase	84
	Gating Input Channels	85
	Attenuating Input Channels	87
	EQ'ing Input Channels	87
	Grouping Input Channel EQs	87
	Input Channel Inserts	87
	Compressing Input Channels	87
	Grouping Input Channel Compressors	88
	Delaying Input Channels	88
	Muting Input Channels (ON/OFF)	88
	Grouping Input Channel Mutes (ON/OFF)	89
	Input Channel Mute Master	90
	Setting Input Channel Levels	90
	Grouping Input Channel Faders	91
	Group Master for Input Channel Faders	92
	Routing Input Channels	93
	Panning Input Channels	95
	Using Surround Pan	97
	Assigning Surround Channels to Buses	99
	Sending Input Channels to Aux Sends	102
	Soloing Input Channels	102
	Direct Outs	102
	Pairing Input Channels	102
	Viewing Input Channel Settings	102
	Copying Input Channel Settings	102
	Naming Input Channels	102
	Using the MS Stereo Microphone	103
<b>8</b>	<b>Stereo Out</b>	<b>104</b>
	Stereo Out Connectors	104
	Patching the Stereo Out to Outputs	104
	Routing Input Channels to the Stereo Out	104
	Sending Bus Outs to the Stereo Out	104
	Metering the Stereo Out	104
	Monitoring the Stereo Out	104
	Attenuating the Stereo Out	104
	EQ'ing the Stereo Out	104
	Grouping Master EQs	104
	Stereo Out Inserts	104
	Compressing the Stereo Out	105
	Grouping Master Compressors	105
	Muting the Stereo Out (ON/OFF)	105
	Grouping Master Mutes (ON/OFF)	105
	Setting the Stereo Out Level	105
	Grouping Master Faders	105
	Sending the Stereo Out to the Matrix Sends	105
	Balancing the Stereo Out	106
	Delaying the Stereo Out	106
	Inserting GEQs	106
	Viewing Stereo Out Settings	106
	Copying Stereo Out Settings	106
	Naming the Stereo Out	106

<b>9</b>	<b>Bus Outs</b>	<b>107</b>
	Patching Bus Outs to Outputs	107
	Routing Input Channels to Bus Outs	107
	Metering Bus Outs	107
	Monitoring Bus Outs	107
	Attenuating Bus Outs	107
	EQ'ing Bus Outs	107
	Grouping Master EQs	107
	Bus Out Inserts	107
	Compressing Bus Outs	107
	Grouping Master Compressors	107
	Muting Bus Outs (ON/OFF)	108
	Grouping Master Mutes (ON/OFF)	108
	Setting Bus Out Levels	108
	Grouping Master Faders	108
	Sending Bus Outs to Matrix Sends	108
	Delaying Bus Outs	108
	Inserting GEQs	108
	Soloing Bus Outs	108
	Pairing Bus Outs	108
	Sending Bus Outs to the Stereo Out	109
	Viewing Bus Out Settings	109
	Copying Bus Out Settings	109
	Naming Bus Outs	109
<b>10</b>	<b>Aux Sends</b>	<b>110</b>
	Patching Aux Send Masters to Outputs	110
	Setting the Aux Send Mode	110
	Pre-Fader or Post-Fader Aux Sends	111
	Setting Aux Send Levels	111
	Muting Aux Sends (ON/OFF)	112
	Aux Send Pages	112
	Viewing Aux Send Settings	114
	Panning Aux Sends	116
	Excluding Certain Channels from Aux Sends (Mix Minus)	117
	Copying Channel Fader Positions to Aux Sends	118
	Metering Aux Send Masters	118
	Monitoring Aux Send Masters	118
	Attenuating Aux Send Masters	118
	EQ'ing Aux Send Masters	118
	Grouping Master EQs	118
	Aux Send Master Inserts	119
	Compressing Aux Send Masters	119
	Grouping Master Compressors	119
	Muting Aux Send Masters (ON/OFF)	119
	Grouping Master Mutes (ON/OFF)	119
	Settings Aux Send Master Levels	119
	Grouping Master Faders	119
	Sending Aux Sends to Matrix Sends	119
	Delaying Aux Send Masters	119
	Inserting GEQs	120
	Soloing Aux Sends	120
	Pairing Aux Sends	120
	Viewing Aux Send Master Settings	120
	Copying Aux Send Master Settings	120
	Naming Aux Send Masters	120

<b>11 Matrix Sends</b> .....	<b>121</b>
Patching Matrix Send Masters to Outputs .....	121
Pre-Fader or Post-Fader Matrix Sends .....	121
Setting Matrix Send Levels .....	121
Muting Matrix Sends (ON/OFF) .....	122
Matrix Send Pages .....	122
Panning Matrix Sends .....	123
Viewing Matrix Send Settings .....	124
Metering Matrix Send Masters .....	124
Monitoring Matrix Send Masters .....	124
Attenuating Matrix Send Masters .....	125
EQ'ing Matrix Send Masters .....	125
Grouping Master EQs .....	125
Matrix Send Master Inserts .....	125
Compressing Matrix Send Masters .....	125
Grouping Master Compressors .....	125
Muting Matrix Send Masters (ON/OFF) .....	125
Grouping Master Mutes (ON/OFF) .....	125
Setting Matrix Send Master Levels .....	125
Grouping Master Faders .....	126
Balancing Matrix Send Masters .....	126
Delaying Matrix Send Masters .....	126
Soloing Matrix Sends .....	126
Inserting GEQs .....	126
Viewing Matrix Send Master Settings .....	126
Copying Matrix Send Master Settings .....	126
Naming Matrix Send Masters .....	126
<b>12 Common Channel Functions</b> .....	<b>127</b>
Metering .....	127
Attenuating Signals .....	130
Using EQ .....	131
Grouping Output Channel EQs .....	135
Using Inserts .....	135
Compressing Channels .....	137
Grouping Output Channel Compressors .....	140
Delaying Channel Signals .....	141
Soloing Channels .....	142
Pairing Channels .....	144
Grouping Output Channel Faders .....	146
Group Master for the Output Channel Faders .....	147
Grouping Output Channel Mutes (ON/OFF) .....	149
Output Channel Mute Master .....	149
Viewing Channel Parameter Settings .....	150
Viewing Channel Fader Settings .....	151
Copying Channel Settings .....	155
Naming Channels .....	156
<b>13 Monitoring &amp; Talkback</b> .....	<b>158</b>
Control Room Monitoring .....	158
Studio Monitoring .....	159
Surround Monitoring .....	160
Using Talkback & Slate .....	163

---

<b>14 Libraries</b> .....	<b>165</b>
About the Libraries .....	165
General Library Operation .....	165
Channel Library .....	166
Input Patch Library .....	167
Output Patch Library .....	167
GEQ Library .....	168
Effects Library .....	168
Bus to Stereo Library .....	169
Gate Library .....	170
Comp Library .....	171
EQ Library .....	172
Automix Library .....	173
Surround Monitor Library .....	173
<b>15 Internal Effects, Plug-Ins &amp; GEQs</b> .....	<b>174</b>
About the Effects .....	174
Patching Effects Processors .....	174
Preset Effects & Types .....	174
Editing Effects .....	177
Adding Optional Add-On Effects .....	178
About Plug-Ins .....	179
Configuring Plug-Ins .....	180
Editing Plug-Ins .....	181
About the GEQs .....	183
Editing GEQs .....	183
Editing the Graphic EQ Using the Channel Faders .....	184
<b>16 Scene Memories</b> .....	<b>185</b>
About Scene Memories .....	185
Auto Scene Memory Update .....	186
Storing & Recalling Scenes with the SCENE MEMORY Buttons .....	187
Using the Scene Memory Page .....	188
Fading Scenes .....	189
Recalling Scenes Safely .....	190
Sorting Scenes .....	191
Copying and Pasting a Scene (Global Paste) .....	191
<b>17 Automix</b> .....	<b>193</b>
About Automix .....	193
What's Recorded in an Automix? .....	193
Automix Main Page .....	194
AUTOMIX Section .....	198
Channel Strip [AUTO] Buttons .....	199
Automix Memory Page .....	199
Fader Edit Pages .....	199
Selecting the Timecode Source & Frame Rate .....	201
Creating a Time Signature Map .....	202
Recording an Automix .....	202
Inserting Mix Parameters into Automix .....	203
Rerecording Events .....	205
Parameter Recording .....	206
Punching In & Out Individual Parameters .....	207
Playing Back an Automix .....	208
Editing Events Offline .....	209

---

<b>18 MIDI</b> .....	<b>215</b>
MIDI & the DM2000 .....	215
MIDI I/O .....	215
MIDI Port Setup .....	216
MIDI Channel Setup .....	217
Assigning Scenes to Program Changes .....	218
Assigning Parameters to Control Changes .....	219
Controlling Parameters by Using Parameter Changes .....	219
Using Bulk Dump .....	220
<b>19 Pro Tools Remote Layer</b> .....	<b>221</b>
Configuring Windows Computers .....	221
Configuring Macintosh Computers (MacOS 8.6 to 9.2.2) .....	221
Configuring Macintosh Computer (MacOS X) .....	221
Configuring the DM2000 .....	222
Configuring Pro Tools .....	222
Control Surface Operation with the Pro Tools Remote Layer .....	224
Scrolling Windows .....	238
Selecting Channels .....	239
Assigning Inputs to Channels .....	239
Assigning Outputs to Channels .....	240
Setting Channel Levels .....	240
Muting Channels .....	241
Panning Channels .....	241
Soloing Channels .....	241
Assigning Send Destinations .....	242
Configuring Sends as Pre or Post .....	242
Setting Send Levels .....	243
Muting Sends .....	243
Panning Sends .....	243
Flip Mode .....	243
Assigning Inserts/Plug-ins .....	244
Editing Plug-ins .....	245
Bypassing Individual Plug-ins .....	246
Bypassing all Plug-ins .....	246
Resetting Faders, Sends, Panpots & Plug-ins .....	247
Navigating the Edit Window .....	247
Zooming .....	248
Making Fine Adjustments to the Selected Region .....	248
Scrub & Shuttle .....	249
Automation .....	250
Panner .....	252
<b>20 Remote Control</b> .....	<b>253</b>
About Remote Layers .....	253
About Machine Control (MMC & P2) .....	256
GPI (General Purpose Interface) .....	264
Controlling AD8HR/AD824 A/D Converters .....	267
<b>21 Other Functions</b> .....	<b>269</b>
Using the User Assignable Layers .....	269
Using the User Defined Keys .....	270
Saving DM2000 Data to SmartMedia .....	271
Setting Preferences .....	274
Using the Oscillator .....	279

Operation Lock ..... 280  
 Checking the Battery and the System Version ..... 282  
 Initializing the DM2000 ..... 282  
 Initializing the Password ..... 282

**Appendix A: Parameter Lists ..... 283**

USER DEFINED KEYS ..... 283  
 USER DEFINED KEYS Initial Assignments ..... 285  
 Input Patch Parameters ..... 286  
 Initial Input Patch Settings ..... 289  
 Output Patch Parameters ..... 290  
 Initial Output Patch Settings ..... 297  
 Initial Input Channel Names ..... 298  
 Initial Output Channel Names ..... 299  
 Initial Input Port Names ..... 300  
 Initial Output Port Names ..... 301  
 GPI Trigger Source & Target List ..... 302  
 User Defined Remote Layer Initial Bank Settings ..... 306  
 Effects Parameters ..... 310  
 Effects and tempo synchronization ..... 331  
 Preset EQ Parameters ..... 332  
 Preset Gate Parameters  
 (fs = 44.1 kHz) ..... 333  
 Preset Compressor Parameters (fs = 44.1 kHz) ..... 334  
 Dynamics Parameters ..... 336

**Appendix B: Specifications ..... 341**

General Spec ..... 341  
 Libraries ..... 346  
 Analog Input Spec ..... 347  
 Analog Output Spec ..... 347  
 Digital Input Spec ..... 348  
 Digital Output Spec ..... 348  
 I/O Slot Spec ..... 349  
 Control I/O Spec ..... 349  
 Connector Pin Assignments ..... 350  
 Dimensions ..... 351

**Appendix C: MIDI ..... 352**

Scene Memory to Program Change Table ..... 352  
 Initial Parameter to Control Change Table ..... 353  
 MIDI Data Format ..... 369  
 Format Details ..... 369

**Appendix D: Options ..... 386**

MB2000 Peak Meter Bridge ..... 386  
 SP2000 Wooden Side Panels ..... 388

**Index ..... 389**



---

# 1 Welcome

---

Thank you for choosing the Yamaha DM2000 Digital Production Console. Designed with production in mind, the DM2000 Digital Production Console offers 24-bit/96 kHz digital audio processing without compromise, comprehensive surround mixing and monitoring, including bass management and down mixing, and hands-on control of popular DAW (Digital Audio Workstation) systems.

## Sonic Spec

- Linear 24-bit, 128-times oversampling A/D converters
- Linear 24-bit, 128-times oversampling D/A converters
- 20 Hz–40 kHz (0.5, –1.5 dB) frequency response at 96 kHz sampling rate
- 108 dB typical dynamic range (AD Input to Stereo Out)
- 32-bit internal signal processing (58-bit accumulator)

## Channel Architecture

- 96 Input Channels, with Direct Outs
- 8 Bus Outs, with to Stereo Out routing for subgrouping
- 12 Aux Sends
- 4 stereo Matrix Sends (22 x 8 matrix)
- Stereo Out
- Channels can be named for easy identification
- Channel library with 127 user memories
- Copy and paste channel settings

## I/O Architecture

- 24 analog mic/line inputs on balanced XLRs and phone jacks (plus 48 V phantom)
- 24 analog inserts on individual in/out phone jacks
- 48 inputs, 48 outputs via six mini-YGDAI slots and optional I/O cards, which offer a variety of analog and digital I/O options, with support for all the popular digital audio interconnect formats, including AES/EBU, ADAT, Tascam TDIF-1, and mLAN.
- 8 assignable Omni outputs
- 2 AES/EBU, 1 Coaxial 2-track digital input
- 2 AES/EBU, 1 Coaxial 2-track digital output
- 2 analog 2-track inputs
- XLR and phone jack stereo outputs
- Large and small control room outputs
- Dedicated studio monitor outputs
- AES/EBU and Coaxial I/O sampling rate converters for connecting 44.1/48 kHz legacy digital audio equipment
- Double channel digital I/O for use with legacy 44.1/48 kHz multitrack recorders
- Cascade ports for cascading up to four DM2000s (i.e., 384 Input Channels)

## **I/O Patching**

- Any available input port can be patched to the Input Channels, Insert Ins, or Effects inputs
- Direct Outs, Insert Outs, Bus Outs, Aux Sends, Matrix Sends, and the Stereo Out can be patched to any output port
- Input and output ports can be named for easy identification
- Patches can be stored in the Input and Output Patch libraries

## **EQ & GEQ**

- 4-band parametric EQ on all Input and Output Channels
- EQ library with 40 presets, 160 user memories
- Six 31-band graphic equalizers that can be patched into Output Channels
- GEQ library with 128 user memories

## **Groups & Pairs**

- Horizontal and vertical pairing of Input Channels
- Horizontal pairing of Bus Outs, Aux Sends, and Surround Pan
- 8 Input Channel, 4 Output Channel Fader groups
- 8 Input Channel, 4 Output Channel Mute groups
- 4 Input Channel, 4 Output Channel EQ groups
- 4 Input Channel, 4 Output Channel Compressor groups

## **Effects**

- 8 internal effects processors
- Effects library with 61 presets, 67 user memories (presets 53–61 are used for optional Add-On Effects.)
- Optional Add-On Effect package includes effects that featuring new algorithms.
- Multichannel effects for surround sound processing
- Joystick control of early reflections and reverb with the Reverb 5.1 effect
- Optional Waves 56K effects plug-in card
- User defined plug-ins for external effects control via MIDI, with Learn function

## **Dynamics**

- Gates on all 96 Input Channels
- Gate library with 4 presets, 124 user memories
- Compressors on all Input Channels and Out Channels (126 in total)
- Compressor library with 36 presets, 92 user memories

## **Automation**

- Dynamic automation of virtually all mix parameters, with 1/4-frame accuracy
- Automix library with 16 memories
- Snapshot style automation with 99 Scene memories, recallable via MIDI or Automix
- Individual fade time settings for all Input and Output faders
- Scene and library recalls
- Punch in/out entire channels with dedicated [AUTO] buttons, or individual parameters
- Editing fader moves with Fader Return, Fader Takeover, Absolute/Relative modes
- Offline event editing includes, erase, copy, move/merge, trim, duplicate, delete, and insert

---

## Surround Sound

- 3-1, 5.1 and 6.1 Surround modes
- Joystick control
- Bass management
- Down mixing
- Surround monitor speaker alignment functions
- Surround monitor library with 32 user memories

## Remote Control

- Control and manage your DM2000 from your Mac or PC by using the bundled Studio Manager software
- Remote Layers for external equipment control, including predefined targets for controlling DAW systems, and user defined targets for controlling MIDI equipment, with Learn function
- Comprehensive machine control via MMC or P2, including transport, track arming, jog/shuttle, and built-in locator with eight Locate memories, all with independent control of master and MTR machines
- Assignable GPI (General Purpose Interface) port for external control and “Recording” light
- Remote control of parameters on up to 12 Yamaha AD8HR/AD824 A/D Converters

## MIDI

- Standard MIDI ports, USB TO HOST port, or SERIAL TO HOST port
- USB, and SERIAL offer multiport operation
- Scene recall, mix parameter control, Bulk Dump, MTC and MIDI Clock for Automix synchronization, MMC for external machine control

## Control Surface

- 25 touch-sensitive 100-mm motorized faders (touch sense used to select channels or punch faders in/out during Automix recording)
- Use the faders to set channel levels or Aux/Matrix Send levels
- Use the 24 Encoders to control Pan, Aux/Matrix Send levels, or user assigned parameters
- Channels arranged into four Input Layers, Master Layer, and four Remote Layers
- 320 x 240 dot LCD display with fluorescent backlight
- Fluorescent channel strip displays, showing channel names, Encoder status, routing, etc.
- Complete hands-on control of all channel functions via the SELECTED CHANNEL section
- 2-digit Scene memory display
- 4 EQ displays for frequency, gain, and Q
- 16 user-definable buttons make light work of repetitive tasks
- Display History buttons for quick access to recently viewed display pages
- SmartMedia card slot for Automix, Scene, library, and setup data storage and transfer
- Optional PS/2-compatible keyboard for quick title entry

# 2 Control Surface & Rear Panel

## Control Surface

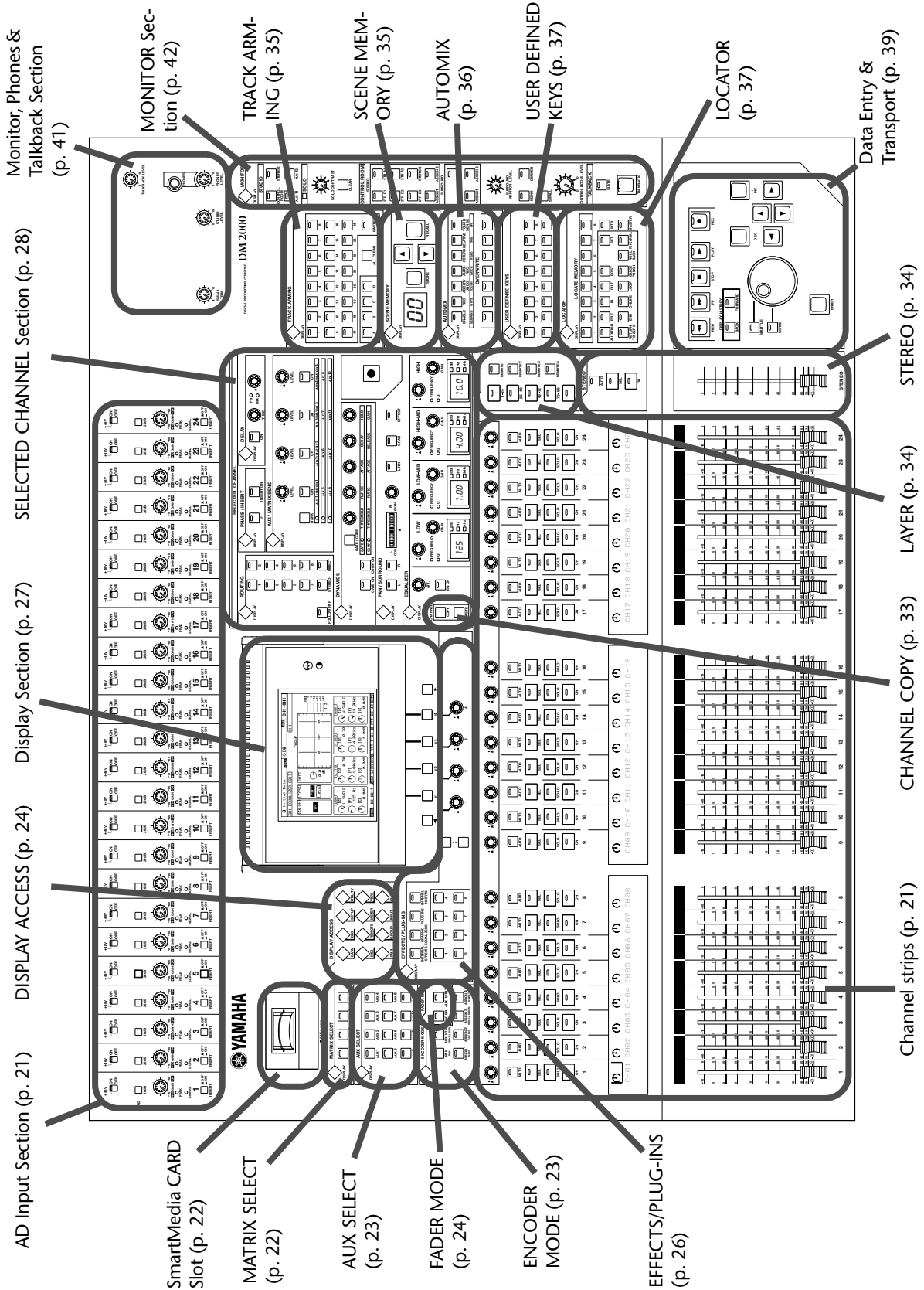

## AD Input Section

AD Input #1 is shown here.

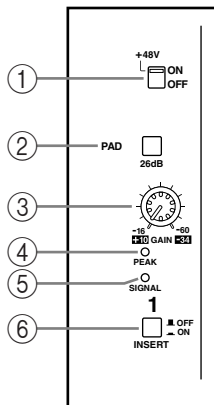

① **+48V ON/OFF switches**

These switches turn on and off the +48 V phantom power feed to each INPUT A (XLR-type connector). Phantom power is typically used to power condenser-type microphones or direct boxes. See “Phantom Power” on page 64 for more information.

② **PAD switches**

These switches turn on and off the 26 dB pad (attenuator) for each AD Input. See “Pad” on page 64 for more information.

③ **GAIN controls**

These controls adjust the gain of the AD Input Head Amps. They have an input sensitivity of –16 dB to –60 dB or +10 dB to –34 dB when Pad is on. See “Gain” on page 64 for more information.

④ **PEAK indicators**

These indicators light up when the input signal level is 3 dB below clipping. See “PEAK & SIGNAL Indicators” on page 64 for more information.

⑤ **SIGNAL indicators**

These indicators light up when the input signal level is 20 dB below nominal. See “PEAK & SIGNAL Indicators” on page 64 for more information.

⑥ **INSERT ON/OFF switches**

These switches are for turning on and off the AD Input inserts. See “AD Inserts” on page 65 for more information.

## Channel strips

Channel strip #1 is shown here.

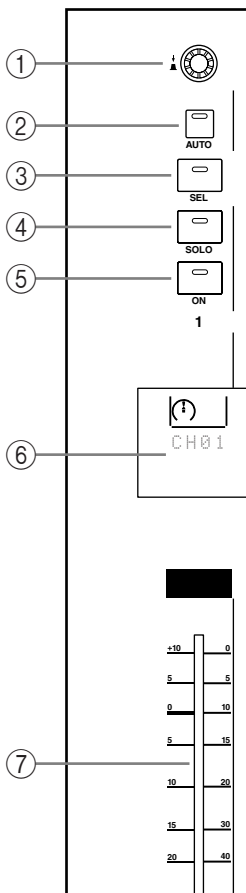

The function of each channel strip depends on the currently selected Layer. See “Selecting Layers” on page 58 for more information.

① **Encoders**

These controls are used to edit Input and Output Channel parameters. Their exact operation depends on the currently selected Encoder mode and Layer. There are two preset Encoder modes, Pan and Aux/Mtrx, and four assignable modes, with over 50 parameters to choose from. See “Selecting Encoder Modes” on page 61 for more information.

The Encoders feature push switches that are used to punch the parameter currently assigned to the Encoders in and out during Automix recording. See “Punching In & Out Individual Parameters” on page 207 for more information.

② **AUTO buttons**

These buttons are used to set Automix recording and playback for each channel. Their exact operation depends on the currently selected Layer. Their indicators light up orange in Record-Ready mode, red while recording, and green during playback. See “Channel Strip [AUTO] Buttons” on page 199 for more information.

③ **SEL buttons**

These buttons are used to select Input and Output Channels for editing with the SELECTED CHANNEL section. Their exact operation depends on the currently selected Layer. The [SEL] button indicator of the currently selected channel lights up. See “Selecting Channels” on page 59 for more information. They are also used to display the Long channel names. See “Channel Names” on page 57 for more information. The [SEL] buttons can also be used to pair channels, and to add and remove channels to and from the EQ, Comp, Fader, and Mute groups.

- ④ **SOLO buttons**  
These buttons are used to solo Channels. The [SOLO] button indicators of channels that are soloed light up. See “Soloing Channels” on page 142 for more information.
- ⑤ **ON buttons**  
These buttons are used to mute Input and Output Channels. Their exact operation depends on the currently selected Layer. The [ON] button indicators of channels that are on light up. You can also use these buttons along with the AUX SELECT buttons to turn Aux Sends on and off (Mix Minus) (page 117).
- ⑥ **Channel strip displays**  
These fluorescent displays graphically display the value of the Input or Output Channel parameter currently assigned to the Encoders. They also display routing settings, and the on/off status of the EQ, Insert, Delay, Comp, and Gate functions. They also display Long and Short channel names and indicate the currently selected channel. When you operate the channel faders or Encoders, they display the corresponding values. See “Channel Strip Displays” on page 55 for more information.
- ⑦ **Channel faders**  
These 100 mm touch-sensitive motorized faders are used to set the levels of Input Channels, Bus Outs, Aux Sends, and Matrix Sends. Their exact operation depends on the currently selected Fader mode and Layer. See “Selecting Fader Modes” on page 60 for more information. Faders can be grouped for simultaneous operation. See “Grouping Input Channel Faders” on page 91 and “Grouping Output Channel Faders” on page 146 for more information.  
  
Faders can also be used to select Input and Output Channels. See “Auto Channel Select & Touch Sense Select” on page 60 for more information. They can also be used to punch channels in and out during Automix recording. See “Punching In & Out Individual Parameters” on page 207 for more information.  
  
Channel faders also enable you to set graphic equalizer curves. See “Editing GEQs” on page 183 for more information.

## SmartMedia CARD Slot

This CARD slot is for use with SmartMedia (3.3 V), which can be used to store DM2000 data, including Setups, Scenes, Automixes, Libraries, and so on. See “Saving DM2000 Data to SmartMedia” on page 271 for more information.

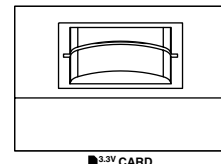

## MATRIX SELECT

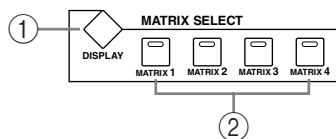

- ① **MATRIX SELECT DISPLAY button**  
This button is used to select the following pages: Matrix Send, Matrix Send Pan, and Matrix View. See “Matrix Sends” on page 121 for more information.
- ② **MATRIX 1–4 buttons**  
These buttons are used to select Matrix Sends when sending Bus Out, Aux Send, and Stereo Out signals to Matrix Sends. The button indicator of the currently selected Matrix Send lights up. See “Matrix Sends” on page 121 for more information.

## AUX SELECT

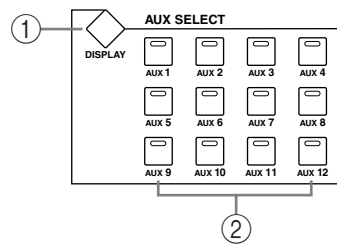

### ① AUX SELECT DISPLAY button

This button is used to select the following pages: Aux Send, Aux Send Pan, and Input Channel Aux View. See “Aux Sends” on page 110 for more information.

### ② AUX 1–12 buttons

These buttons are used to select Aux Sends when sending Input Channel signals to Aux Sends. The button indicator of the currently selected Aux Send lights up. If the currently selected Aux Send is paired, the indicator of its partner flashes. See “Aux Sends” on page 110 for more information.

Using these buttons along with the channel [ON] buttons enables you to turn Aux Sends on and off (Mix Minus) (page 117).

Using these buttons along with the LAYER buttons enables you to copy the corresponding channel levels to the Aux Send levels.

These buttons are also used to turn the Aux Out Solo function on and off when Aux/Solo Link is turned on (page 142).

## ENCODER MODE

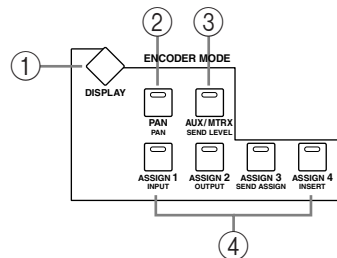

The small text labels below the ASSIGN buttons apply to the DAW Remote Layer. See “About Remote Layers” on page 253 for more information.

### ① ENCODER MODE DISPLAY button

This button is used to select the Encoder Mode Assign page. See “Selecting Encoder Modes” on page 61 for more information.

### ② PAN button

This button is used to select the Pan Encoder mode. Its indicator lights up when this mode is selected. In this mode, the Encoders function as Pan controls when an Input Channel Layer is selected. When the Master Layer is selected, Encoders 21–24 function as Matrix Send Balance controls. The other Encoders are inactive. See “Selecting Encoder Modes” on page 61 for more information.

### ③ AUX/MTRX button

This button is used to select the Aux/Mtrx Encoder mode. Its indicator lights up when this mode is selected. In this mode, the Encoders function as Aux Send level controls when an Input Channel Layer is selected. When the Master Layer is selected, Encoders 1–20 function as Matrix Send level controls. See “Selecting Encoder Modes” on page 61.

#### ④ ASSIGN 1–4 buttons

These buttons are used to select the assignable Encoder modes. The button indicator for the currently selected mode lights up. When an assignable mode is selected, the function of the Encoders depends on the assigned parameter. Up to four parameters, from a list of 50, can be assigned to these four buttons. See “Assigning Parameters to the ENCODER MODE Assign Buttons” on page 62 for more information.

## FADER MODE

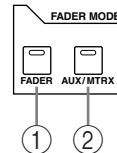

#### ① FADER button

This button selects Fader mode, in which the faders control Input or Output Channel levels, depending on the currently selected Layer. Its indicator lights up when this mode is selected. See “Selecting Fader Modes” on page 60 for more information.

#### ② AUX/MTRX button

This button selects the Aux/Mtrx Fader mode, in which the faders control Aux Send or Matrix Send levels, depending on the currently selected Layer. Its indicator lights up when this mode is selected. See “Selecting Fader Modes” on page 60 for more information.

## DISPLAY ACCESS

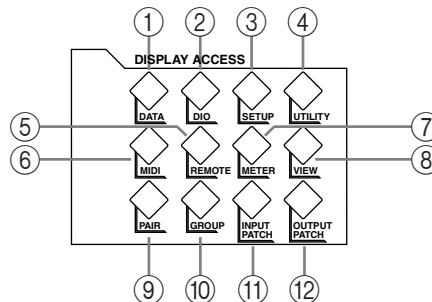

#### ① DATA button

This button is used to select the Save, Load, and File pages, which are used to save and load DM2000 data to SmartMedia. See “Saving DM2000 Data to SmartMedia” on page 271 for more information.

#### ② DIO button

This button is used to select the following pages: Word Clock Select, Dither, Cascade In, Cascade Out, Sampling Rate Converter, and Higher Sample Rate Data Transfer Format. See “Digital I/O & Cascading” on page 66 for more information.

#### ③ SETUP button

This button is used to select the following pages: Preferences 1, Preferences 2, Preferences 3, MIDI/TO HOST Setup, GPI Setup, Input Port Name, Output Port Name, Time Reference, Time Signature, Remote Port Setup, and Surround Bus Setup.

#### ④ UTILITY button

This button is used to select the following pages: Oscillator, Channel Status Monitor, Battery Check, and Operation Lock.

#### ⑤ REMOTE button

This button is used to select the Remote pages. See “About Remote Layers” on page 253 for more information.



- 
- ⑥ **MIDI button**  
This button is used to select the following pages: MIDI Setup, Program Change Assign Table, Control Change Assign Table, and Bulk Dump. See “MIDI” on page 215 for more information.
  - ⑦ **METER button**  
This button is used to select the following pages: Input Channel Meter, Master Meter, Effect Input/Output Meter, Effect 1-8 Input/Output Meter, Effect 1–2 Input/Output Meter, Stereo Meter, and Metering Position. See “Metering” on page 127 for more information.
  - ⑧ **VIEW button**  
This button is used to select the following pages: Parameter View, Fader View, and Channel Library. See “Viewing Channel Parameter Settings” on page 150, “Viewing Channel Fader Settings” on page 151, and “Channel Library” on page 166 for more information.
  - ⑨ **PAIR button**  
This button is used to select the Input and Output Pair pages. See “Pairing Channels” on page 144 for more information.
  - ⑩ **GROUP button**  
This button is used to select the following pages: Fader group, Mute group, Output Fader group, Output Mute group, Input Equalizer Link, Output Equalizer Link, Input Comp Link, Output Comp Link, Input Fader Group Master, and Output Fader Group Master.
  - ⑪ **INPUT PATCH button**  
This button is used to select the following pages: Input Channel Patch, Input Channel Insert In Patch, Effects 1-2 Input/Output Patch, Effects 3–8 Input/Output Patch, Input Channel Name, and Input Patch Library. See “Input Patching” on page 77 for more information.
  - ⑫ **OUTPUT PATCH button**  
This button is used to select the following pages: Slot Output Patch, Omni Out Patch, Output Insert In Patch, Input Channel Direct Out Destination, 2TR Out Digital Patch, Graphic Equalizer Insert, Output Channel Name, and Output Patch Library. See “Output Patching” on page 79 for more information.
-

## EFFECTS/PLUG-INS

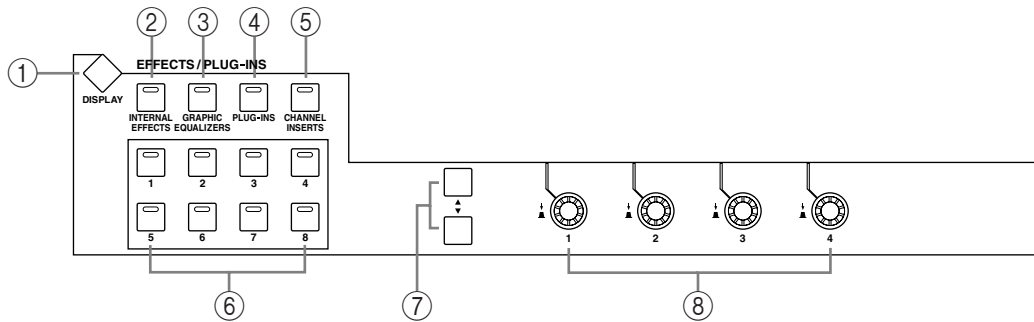

- ① **EFFECTS/PLUG-INS DISPLAY button**  
This button is used to select the following pages: Effects Edit, Effects Library, Graphic Equalizer Edit, Graphic Equalizer Library, Plug-In Setup, and Plug-In Edit. See “Internal Effects, Plug-Ins & GEQs” on page 174 for more information.
- ② **INTERNAL EFFECTS button**  
This button is used to select the internal effects processors in conjunction with the EFFECTS/PLUG-INS [1–8] buttons. Its indicator lights up when it’s pressed. See “Editing Effects” on page 177 for more information.
- ③ **GRAPHIC EQUALIZERS button**  
This button is used to select the GEQs in conjunction with the EFFECTS/PLUG-INS [1–6] buttons. Its indicator lights up when it’s pressed. See “Editing GEQs” on page 183 for more information.
- ④ **PLUG-INS button**  
This button is used to select the Plug-Ins in conjunction with the EFFECTS/PLUG-INS [1–8] buttons. Its indicator lights up when it’s pressed. See “Editing Plug-Ins” on page 181 for more information.
- ⑤ **CHANNEL INSERTS button**  
If an internal effects processor or Y56K card effects chain is inserted in the currently selected channel, the relevant Effects Edit or Plug-In Edit page appears when this button is pressed, and its indicator lights up. In addition, the corresponding EFFECTS/PLUG-INS [1–8] button indicator flashes. If it’s a Y56K that is inserted, the [PLUG-INS] button indicator also flashes. If it’s an internal effects processor, the [INTERNAL EFFECTS] button indicator flashes. A warning message appears if there’s nothing inserted in the currently selected channel. See “Editing Effects” on page 177 and “Editing Plug-Ins” on page 181 for more information.
- ⑥ **EFFECTS/PLUG-INS 1–8 buttons**  
These buttons are used to select the internal effects processors, GEQs, and Plug-Ins in conjunction with the EFFECTS/PLUG-INS [INTERNAL EFFECTS], [GRAPHIC EQUALIZERS], and [PLUG-INS] buttons. The button indicator of the currently selected internal effects processor, GEQ, or Plug-In lights up. Since there are six GEQs, buttons [7] and [8] are inactive when the [GRAPHIC EQUALIZERS] button’s indicator is lit. When the EFFECTS/PLUG-INS [CHANNEL INSERTS] button indicator is lit, all of these buttons are inactive.
- ⑦ **Parameter Up/Down buttons**  
These buttons are used to select the rows of internal effects processor and Plug-In parameters for editing with Parameter controls 1–4. The parameters in the currently selected row appear highlighted. Up to 16 parameters can be displayed at a time. If more are available, an up or down arrow is displayed. See “Editing Effects” on page 177 and “Editing Plug-Ins” on page 181 for more information.

### ⑧ Parameter controls 1–4

These are rotary controls and push switches. The rotary controls are used to edit the parameters of the currently selected internal effects processor, Plug-In, or GEQ. When the Effects Edit page is selected, they control the currently selected row of parameters, rows being selected by the Parameter Up/Down buttons. When the Graphic Equalizer Edit page is selected, Parameter control #1 selects the frequency bands and Parameter control #4 sets the gain of the selected band. Parameter controls #2 and #3 are inactive. See “Editing Effects” on page 177, “Editing Plug-Ins” on page 181, and “Editing GEQs” on page 183 for more information.

The push switches are used to punch the Effects or Plug-In parameters currently being controlled by the rotary controls in and out during Automix recording. See “Punching In & Out Individual Parameters” on page 207 for more information.

## Display Section

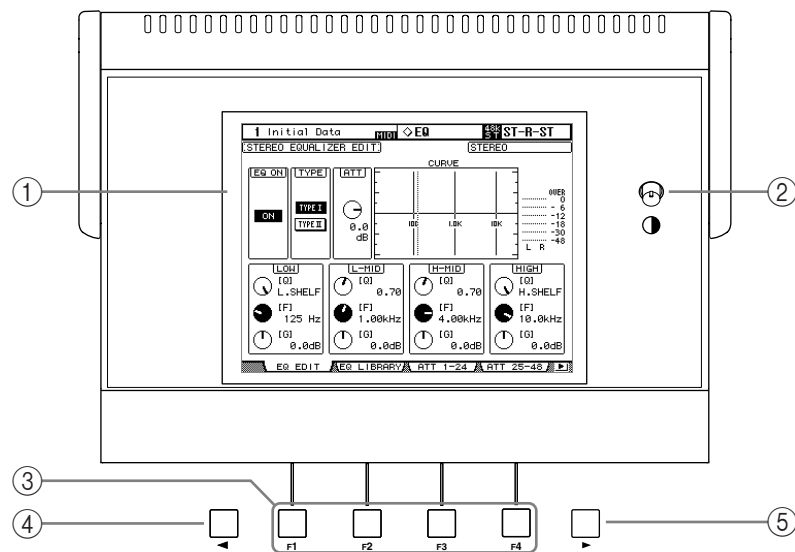

### ① Display

This 320 x 240 dot display with fluorescent backlight displays pages, information on the currently selected Scene and channel, the sampling rate, and more. See “About the Display” on page 52 for more information.

### ② Contrast control

This control is used to adjust the contrast of the display.

### ③ F1–F4 buttons

These buttons are used to select the pages whose tabs are currently visible. See “Selecting Display Pages” on page 53 for more information.

### ④ Left Tab Scroll button

This button, which is active only when the left Tab Scroll arrow is displayed, is used to display the tabs of pages available to the left of the currently selected page. See “Selecting Display Pages” on page 53 for more information.

### ⑤ Right Tab Scroll button

This button, which is active only when the right Tab Scroll arrow is displayed, is used to display the tabs of pages available to the right of the currently selected page. See “Selecting Display Pages” on page 53 for more information.

## SELECTED CHANNEL Section

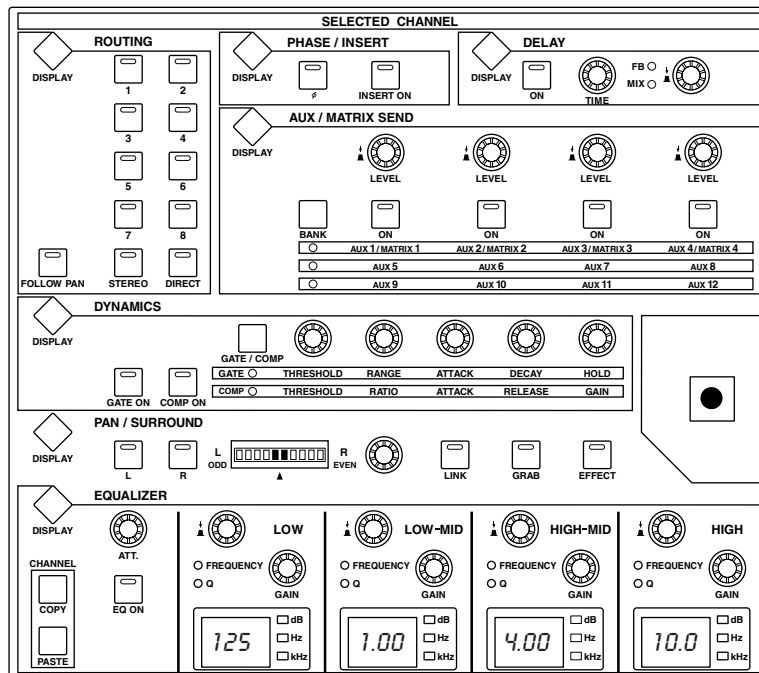

The subsections of the SELECTED CHANNEL section are explained below.

### ROUTING

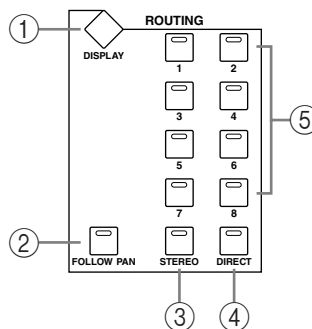

- ① **ROUTING DISPLAY button**  
This button is used to select the following pages: Input Channel Routing, Bus to Stereo, and Bus to Stereo Library. See “Routing Input Channels” on page 93 and “Sending Bus Outs to the Stereo Out” on page 109 for more information.
- ② **FOLLOW PAN button**  
This button determines whether or not the currently selected Input Channel’s pan setting, and Surround pan setting are applied to the Bus Outs. Its indicator lights up when it’s pressed. See “Routing Input Channels” on page 93 for more information.
- ③ **STEREO button**  
This button is used to route the currently selected Input Channel to the Stereo Out. Its indicator lights up when it’s pressed. See “Routing Input Channels” on page 93 for more information.
- ④ **DIRECT button**  
This button is used to route the currently selected Input Channel to its Direct Out. Its indicator lights up when it’s pressed. See “Routing Input Channels” on page 93 for more information.

**⑤ ROUTING 1–8 buttons**

These buttons are used to route the currently selected Input Channel to the Bus Outs. The button indicators of Bus Outs to which the Input Channel is routed light up. See “Routing Input Channels” on page 93 for more information.

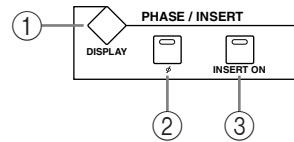
**PHASE/INSERT****① PHASE/INSERT DISPLAY button**

This button is used to select the Input Channel Phase and Insert pages. See “Reversing the Signal Phase” on page 84 and “Using Inserts” on page 135 for more information.

**② Phase [∅] button**

This button is used to reverse the signal phase of the currently selected Input Channel. Its indicator lights up when the phase is reversed. See “Reversing the Signal Phase” on page 84 for more information.

**③ INSERT ON button**

This button is used to turn on and off the Insert of the currently selected channel. Its indicator lights up when the Insert is on. See “Using Inserts” on page 135 for more information.

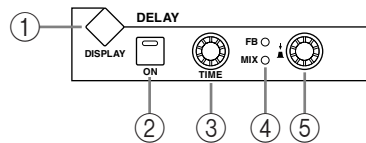
**DELAY****① DELAY DISPLAY button**

This button is used to select the Delay pages. See “Delaying Channel Signals” on page 141 for more information.

**② ON button**

This button is used to turn on and off the Delay of the currently selected channel. Its indicator lights up when the Delay function is on. See “Delaying Channel Signals” on page 141 for more information.

**③ TIME control**

This control is used to set the delay time of the currently selected channel’s Delay function. See “Delaying Channel Signals” on page 141 for more information.

**④ FB/MIX indicators**

These indicators show whether the FB/MIX control is set to control Feedback Gain or Feedback Mix. The FB indicator lights up when it’s set to control Feedback Gain; the MIX indicator, when its set to control Feedback Mix. See “Delaying Channel Signals” on page 141 for more information.

**⑤ FB/MIX control**

This is a rotary control and push switch. When the currently selected channel is an Input Channel, the push switch can be used to select either Feedback Gain (FB) or Feedback Mix (MIX). The rotary control is used to set the Feedback Gain or Feedback Mix, as selected by the push switch. See “Delaying Channel Signals” on page 141 for more information.

## AUX/MATRIX SEND

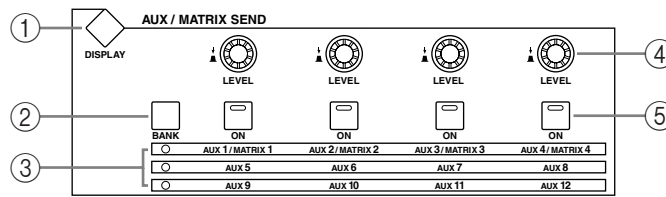

### ① AUX/MATRIX SEND DISPLAY button

The pages selected by this button depends on the type of channel currently selected. If it's an Input Channel, it selects the Aux Send, Aux Send Pan, and Input Channel Aux View pages. If it's an Output Channel, it selects the Matrix Send, Matrix Send Pan, and Matrix View pages.

### ② BANK button

This button is used to select Aux 1–4/Matrix 1–4, Aux 5–8, or Aux 9–12 for use with the AUX/MATRIX LEVEL controls and [ON] buttons. When an Output Channel is selected, the Aux 1–4/Matrix 1–4 bank is selected automatically and cannot be changed. See “Using the SELECTED CHANNEL AUX/MATRIX SEND LEVEL Controls” on page 111 for more information.

### ③ Bank indicators

These indicators show which bank of Aux/Matrix Sends has been selected by the [BANK] button. When an Output Channel is selected, the Aux 1–4/Matrix 1–4 bank is selected automatically and cannot be changed.

### ④ LEVEL controls

These controls are used to set the levels of the Aux or Matrix Send currently selected by the [BANK] button. If the currently selected channel is an Input Channel, they control Aux Send levels. If it's a Bus Out, Aux Send, or the Stereo Out, they control Matrix Send levels. See “Setting Aux Send Levels” on page 111 and “Setting Matrix Send Levels” on page 121 for more information.

### ⑤ ON buttons

These buttons are used to mute the Aux/Matrix Sends currently selected by the [BANK] button. The button indicators of channels that are on light up. If the currently selected channel is an Input Channel, they mute Aux Sends. If the currently selected channel is a Bus Out, Aux Send, or the Stereo Out, they mute Matrix Sends. See “Muting Aux Sends (ON/OFF)” on page 112 and “Muting Matrix Sends (ON/OFF)” on page 122 for more information.

## DYNAMICS

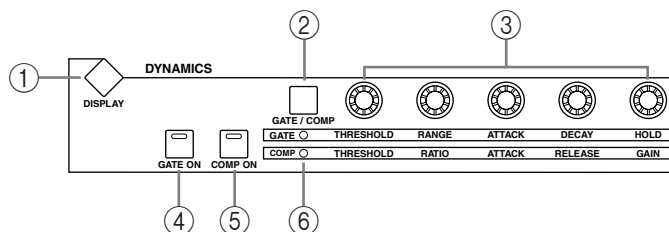

### ① DYNAMICS DISPLAY button

This button is used to select the following pages: Gate Edit, Gate Library, Comp Edit, and Comp Library. See “Gating Input Channels” on page 85 and “Compressing Channels” on page 137 for more information.

**② GATE/COMP button**

This button is used to set the rotary controls for either Gate or Compressor operation. When an Output Channel is selected, Compressor is selected automatically and cannot be changed. See “Gating Input Channels” on page 85 and “Compressing Channels” on page 137 for more information.

**③ THRESHOLD, RANGE, ATTACK, DECAY, HOLD (THRESHOLD, RATIO, ATTACK, RELEASE, GAIN) controls**

When the GATE/COMP button is set to GATE, these controls set the Threshold, Range, Attack, Decay, and Hold parameters of the currently selected Input Channel’s Gate. When it’s set to COMP, they set the Threshold, Ratio, Attack, Release, and Gain parameters of the currently selected channel’s Compressor. See “Gating Input Channels” on page 85 and “Compressing Channels” on page 137 for more information.

**④ GATE ON button**

This button is used to turn the currently selected Input Channel’s Gate on and off. Its indicator lights up when the Gate is on. See “Gating Input Channels” on page 85 for more information.

**⑤ COMP ON button**

This button is used to turn the currently selected channel’s Compressor on and off. Its indicator lights up when the Compressor is on. See “Compressing Channels” on page 137 for more information.

**⑥ GATE/COMP indicators**

These indicators show whether the rotary controls are set to control either a Gate or a Compressor. The GATE indicator lights up when they’re set to control a Gate; the COMP indicator, when they’re set to control a Compressor. See “Gating Input Channels” on page 85 and “Compressing Channels” on page 137 for more information.

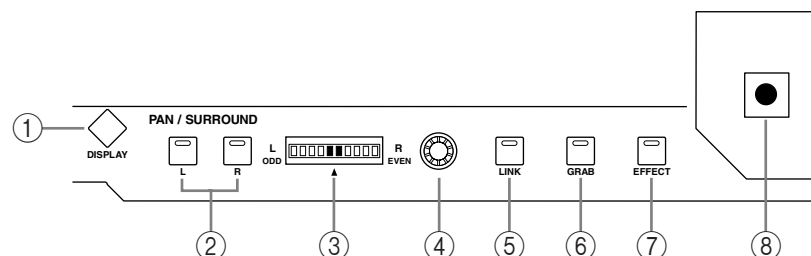
**PAN/SURROUND****① PAN/SURROUND DISPLAY button**

This button is used to select the Input Channel Pan pages, the Surround Mode page, and the Surround Edit pages. See “Panning Input Channels” on page 95 and “Using Surround Pan” on page 97.

**② L & R buttons**

These buttons can be used to select horizontally or vertically partnered Input or Output Channels. They can be used to select the left and right channels when a Matrix Send or the Stereo Out is selected. For Input Channels, in Individual Pan mode, the [L] button indicator lights up when an odd/left channel is selected; the [R] button indicator, when an even/right channel is selected. In Gang or Inverse Gang Pan mode, the button indicator of the other channel in the pair flashes when its partner is selected.

**③ PAN display**

This 10-segment display indicates the pan position of the currently selected Input Channel. When pan is set to center, the center two segments light up. When a Matrix Send or the Stereo Out is selected, it displays the balance.

④ **PAN control**

This rotary control is used to pan the currently selected Input Channel. When a Matrix Send or the Stereo Out is selected, it is used to set the balance. For Input Channels in Gang or Inverse Gang Pan mode, horizontally or vertically paired Input Channels are panned simultaneously. See “Panning Input Channels” on page 95, “Balancing the Stereo Out” on page 106, and “Balancing Matrix Send Masters” on page 126.

⑤ **LINK button**

This button, which is enabled only when a Surround mode other than Stereo is selected, is used to link the PAN control and the Joystick so that either control can be used for normal and surround panning. It’s a global setting that applies to all Input Channels. Its indicator lights up when the PAN control and Joystick are linked. If the Joystick is set to control effects (i.e., the [EFFECT] button indicator is lit), this button is disabled. See “Panning Input Channels” on page 95 and “Using Surround Pan” on page 97 for more information.

⑥ **GRAB button**

This button is used to turn on and off Joystick control for the currently selected Input Channel. Its indicator lights up when Grab is on. When Grab is on, the Joystick can be used to control the currently selected Input Channel’s surround pan position. When turned off, the Joystick does not control surround pan. In Stereo mode, it controls the currently-selected Input Channel’s pan position. If the PAN control and the Joystick are linked (i.e., the [LINK] button indicator is lit), Grab is turned off if the PAN control is adjusted. If the Joystick is set to control effects (i.e., the [EFFECT] button indicator is lit), this button is disabled.

⑦ **EFFECT button**

This button is used to select the Joystick for parameter control of the Reverb 5.1 effect. Its indicator lights up when Reverb 5.1 effect control is on, and the Joystick cannot be used for surround panning. See “REVERB 5.1” on page 326 for more information.

⑧ **Joystick**

This control can be used for surround panning, normal panning, or parameter control of the Reverb 5.1 effect. When the [EFFECT] button indicator is lit, the Joystick controls the Reverb 5.1 effect. See “REVERB 5.1” on page 326 for more information. When the [EFFECT] button indicator is off and the [GRAB] button indicator is on, the Joystick controls surround panning of the currently selected Input Channel. When the [EFFECT] button and [GRAB] button indicators are both off, the Joystick can still be used for surround panning if the Auto Grab preference is on. See “Using Surround Pan” on page 97 for more information. When the [EFFECT] button indicator is off but the [GRAB] button and [LINK] button indicators are both on, the Joystick can be used for normal panning in unison with the PAN control. See “Panning Input Channels” on page 95 for more information.

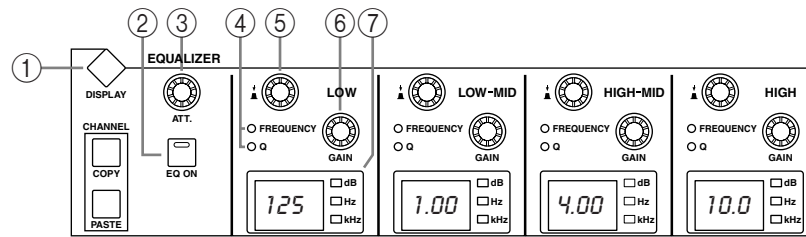

**EQUALIZER**

- ① **EQUALIZER DISPLAY button**  
This button is used to select the following pages: Equalizer Edit, Equalizer Library, Input Channel Attenuator/Shifter, and Output Attenuator.
- ② **EQ ON button**  
This button is used to turn the EQ of the currently selected channel on and off. Its indicator lights up when the EQ is on. See “Using EQ” on page 131 for more information.
- ③ **ATT control**  
This control is used to attenuate the pre-EQ signal of the currently selected channel. See “Attenuating Signals” on page 130 for more information.
- ④ **FREQUENCY/Q indicators**  
These indicators show whether each FREQUENCY/Q control is set to control frequency or Q. The FREQUENCY indicator lights up when it’s set to control frequency; the Q indicator, when it’s set to control Q. See “Using EQ” on page 131 for more information.
- ⑤ **FREQUENCY/Q controls**  
These are rotary controls and push switches. The push switches are used to select either frequency or Q. The current setting is shown by the FREQUENCY/Q indicators. The rotary controls are used to set the frequency or Q, as selected by the push switches. See “Using EQ” on page 131 for more information.
- ⑥ **EQ GAIN controls**  
These controls are used to set the gain of each EQ band. See “Using EQ” on page 131 for more information.
- ⑦ **EQ displays**  
Normally these displays show the frequency of each band. When the GAIN is adjusted, the gain value is displayed. When the Q is adjusted, the Q value is displayed. If the gain or Q is not adjusted for two seconds, the frequency value reappears. See “Using EQ” on page 131 for more information.

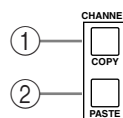
**CHANNEL COPY**

- ① **COPY button**  
This button is used to copy channel settings to the Copy buffer. See “Copying Channel Settings” on page 155 for more information.
- ② **PASTE button**  
This button is used to paste the settings in the Copy buffer to the specified channel. See “Copying Channel Settings” on page 155 for more information.

## LAYER

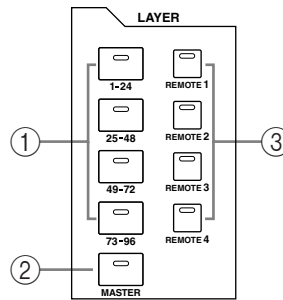

① **1–24, 25–48, 49–72 & 73–96 buttons**

These buttons select the Input Channel Layers, which determine which Input Channels are controlled by the channel strips. The LAYER button indicator for the currently selected Layer lights up. See “Selecting Layers” on page 58 for more information.

② **MASTER button**

This button selects the Master Layer, from which the channel strips control Bus Outs, Aux Sends, and Matrix Sends. Its indicator lights up when the Master Layer is selected. See “Selecting Layers” on page 58 for more information.

③ **REMOTE 1–4 buttons**

These buttons select the Remote Layers, which can be used to control external devices, including DAWs. See “About Remote Layers” on page 253 for more information. The LAYER button indicator for the currently selected Remote Layer lights up. See “Selecting Layers” on page 58 for more information.

## STEREO

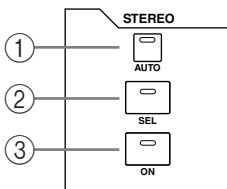

① **AUTO button**

This button is used exclusively to set Automix recording and playback for the Stereo Out. Its indicator lights up orange in Record-Ready mode, red while recording, and green during playback. See “Channel Strip [AUTO] Buttons” on page 199 for more information.

② **SEL button**

The Stereo Out [SEL] button is used exclusively to select the Stereo Out for editing with the SELECTED CHANNEL section. Its indicator lights up when the Stereo Out is selected. Each time it’s pressed, the selection toggles between the Stereo Out’s left and right channels. See “Selecting Channels” on page 59 for more information. It can also be used to add and remove the Stereo Out to and from EQ, Comp, Fader, and Mute groups.

③ **ON button**

This button is used exclusively to mute the Stereo Out. Its indicator lights up when the Stereo Out is on. See “Muting the Stereo Out (ON/OFF)” on page 105 for more information.

④ **Fader**

This 100 mm touch-sensitive motorized fader is used exclusively to adjust the level of the Stereo Out. See “Setting the Stereo Out Level” on page 105 for more information. It can be grouped with other Output Channel faders for simultaneous operation. See “Grouping Output Channel Faders” on page 146 for more information. It can also be used to select the Stereo Out, see “Auto Channel Select & Touch Sense Select” on page 60, or to punch the Stereo Out in and out during Automix recording. See “Punching In & Out Individual Parameters” on page 207 for more information.

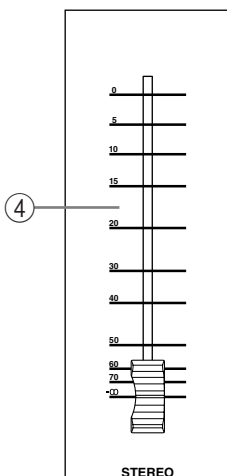

## TRACK ARMING

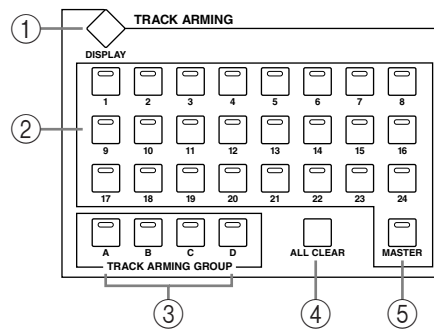

- ① **TRACK ARMING DISPLAY button**  
This button is used to select the following pages: Track Arming Group, MTR Track Arming Configuration, and Master Track Arming Configuration. See “Arming Machine Tracks” on page 261 for more information.
- ② **TRACK ARMING 1–24 buttons**  
These buttons are used to arm tracks on the target machine (DAW, MMC or P2). Their indicators light up when tracks are armed. See “Arming Machine Tracks” on page 261 for more information.
- ③ **TRACK ARMING GROUP A–D buttons**  
These buttons arm all tracks assigned to the corresponding track arming groups A, B, C, and D. If all tracks in the currently-selected group are armed, the button indicator for the corresponding group lights up. See “Arming Machine Tracks” on page 261 for more information.
- ④ **ALL CLEAR button**  
This button is used to clear all track arming on the target machine (DAW, MMC or P2). See “Arming Machine Tracks” on page 261 for more information.
- ⑤ **MASTER button**  
This button is used to select Master or MTR machines for track arming. Its indicator lights up when Master is selected, and is off when MTR is selected. See “About Machine Control (MMC & P2)” on page 256 for more information.

## SCENE MEMORY

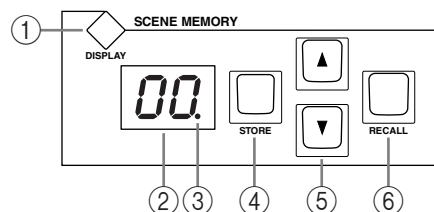

- ① **SCENE MEMORY DISPLAY button**  
This button is used to select the following pages: Scene Memory, Input Channel Fade Time, Output Fade Time, Recall Safe, and Scene Memory Sort. See “Scene Memories” on page 185 for more information.
- ② **Scene memory display**  
This displays the number of the currently selected Scene memory. See “Scene Memories” on page 185 for more information.
- ③ **Edit indicator**  
This indicates that the current mix settings no longer match those of the Scene that was recalled last. See “Edit Buffer & Edit Indicator” on page 185 for more information.

- ④ **STORE button**  
This button is used to store the current Scene to the selected Scene memory. See “Storing & Recalling Scenes with the SCENE MEMORY Buttons” on page 187.
- ⑤ **Scene Up/Down buttons**  
These buttons are used to select Scene memories. Pressing the Scene Up [▲] button increments the selection; pressing the Scene Down [▼] button decrements the selection. Holding down a button causes the selection to increment/decrement continuously. See “Storing & Recalling Scenes with the SCENE MEMORY Buttons” on page 187.
- ⑥ **RECALL button**  
This button is used to recall the selected Scene memory. See “Storing & Recalling Scenes with the SCENE MEMORY Buttons” on page 187.

## AUTOMIX

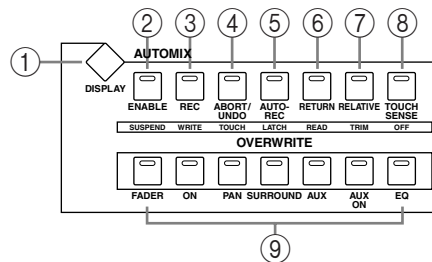

The small text labels below the AUTOMIX buttons apply to the DAW Remote Layer. See “About Remote Layers” on page 253 for more information.

- ① **AUTOMIX DISPLAY button**  
This button is used to select the following pages: Automix Main, Automix Memory, Input Channel Fader Edit, Event Copy, and Event Edit. See “Automix” on page 193.
- ② **ENABLE button**  
This button is used to enable and disable the Automix function. It works in unison with the ENABLED/DISABLED button on the Automix Main page. See “Automix Main Page” on page 194.
- ③ **REC button**  
This button is used with Automix recording. It works in unison with the REC button on the Automix Main page. See “REC” on page 197 for more information.
- ④ **ABORT/UNDO button**  
This button is used to abort Automix recording or playback. It works in unison with the ABORT button on the Automix Main page. See “ABORT” on page 197. When not recording or playing an Automix, it’s used to undo the Automix, in unison with the UNDO button on the Automix Main page. See “UNDO” on page 197 for more information.
- ⑤ **AUTO-REC button**  
This button is used to arm Automix Auto Recording function. It works in unison with the AUTO REC button on the Automix Main page. See “AUTO REC” on page 197 for more information.
- ⑥ **RETURN button**  
This button is used to select the Automix Edit Out mode. It works in unison with the EDIT OUT RETURN buttons on the Automix Main page. See “EDIT OUT” on page 195 for more information.
- ⑦ **RELATIVE button**  
This button is used to set the Automix Fader Edit mode. It works in unison with the FADER EDIT buttons on the Automix Main page. See “FADER EDIT” on page 196 for more information.

**⑧ TOUCH SENSE button**

This button is used to turn on and off Fader Touch Sense for Automix recording. See “Fader Edit Pages” on page 199 for more information.

**⑨ FADER, ON, PAN, SURROUND, AUX, AUX ON & EQ buttons**

These buttons are used to select the type of parameters that are recorded in an Automix. They work in unison with their counterparts on the Automix Main and Memory pages. See “OVERWRITE” on page 196 for more information.

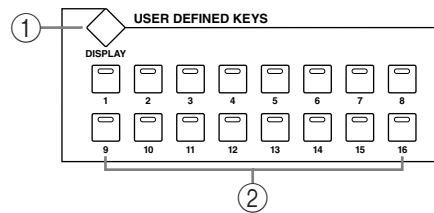
**USER DEFINED KEYS****① USER DEFINED KEYS DISPLAY button**

This button is used to select the User Defined Key Assign page. See “Using the User Defined Keys” on page 270 for more information.

**② USER DEFINED KEYS 1–16 buttons**

Up to 16 functions, from a list of over 214, can be assigned to these buttons. See “Using the User Defined Keys” on page 270 for more information. These buttons have specific functions when the DAW Remote Layer is selected. See “About Remote Layers” on page 253 for more information.

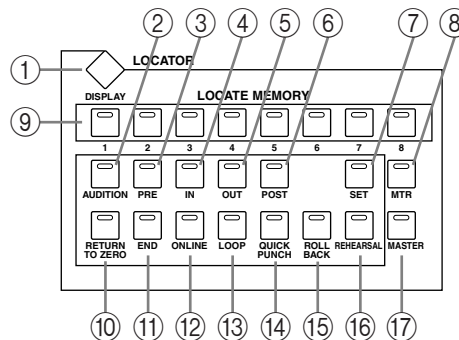
**LOCATOR****① LOCATOR DISPLAY button**

This button is used to select the Locate Memory and Machine Configuration pages. See “Setting the Locate Memories, Pre-roll, Post-roll & Roll-back” on page 260 and “Configuring Machines” on page 256 respectively for more information.

**② AUDITION button**

This button is used to turn on and off the Audition function on the target machine (DAW, MMC or P2). Its indicator lights up while the Audition function is on. See “Using the Locator” on page 258 for more information.

**③ PRE button**

Pressing this button transmits a Locate command to the target machine (DAW, MMC or P2) in order to locate the Pre-Roll point. Its indicator lights up momentarily when it’s pressed. The Pre-Roll point is a predefined number of seconds before the specified In point. See “Using the Locator” on page 258 for more information.

- ④ **IN button**

Pressing this button transmits a Locate command to the target machine (DAW, MMC or P2) in order to locate the In point. Its indicator lights up momentarily when it's pressed. See "Using the Locator" on page 258 for more information.
- ⑤ **OUT button**

Pressing this button transmits a Locate command to the target machine (DAW, MMC or P2) in order to locate the Out point. Its indicator lights up momentarily when it's pressed. See "Using the Locator" on page 258 for more information.
- ⑥ **POST button**

Pressing this button transmits a Locate command to the target machine (DAW, MMC or P2) in order to locate the Post-Roll point. Its indicator lights up momentarily when it's pressed. The Post-Roll point is a predefined number of seconds after the specified Out point. See "Using the Locator" on page 258 for more information.
- ⑦ **SET button**

This button is used when specifying the eight Locate points, In point, Out point, and Return to Zero point. Its indicator lights up while it's pressed. See "Using the Locator" on page 258 for more information.
- ⑧ **MTR button**

This button is used to select the MTR machine for Locator, Transport, Scrub, and Shuttle control (MMC or P2). Its indicator lights up when MTR is selected (the [MASTER] button indicator goes off). See "Using the Locator" on page 258 for more information.
- ⑨ **LOCATE MEMORY 1–8 buttons**

Pressing these buttons transmits Locate commands to the target machine (DAW, MMC or P2) in order to locate the Locate memory points. Their indicators light up momentarily when they're pressed. See "Using the Locator" on page 258 for more information.
- ⑩ **RETURN TO ZERO button**

Pressing this button transmits a Locate command to the target machine (DAW, MMC or P2) in order to locate the Return to Zero point. Its indicator lights up momentarily when it's pressed. See "Using the Locator" on page 258 for more information.
- ⑪ **END button**

Pressing this button transmits a Locate command when using the DAW Remote Layer in order to locate the end of the session. Its indicator lights up momentarily when it's pressed. See "About Remote Layers" on page 253 for more information.
- ⑫ **ONLINE button**

This button is used to turn the Chase function on and off on the target machine (DAW, MMC or P2). Its indicator lights up while the Chase function is on. See "Using the Locator" on page 258 for more information.
- ⑬ **LOOP button**

This button is used to turn on and off Loop Playback on the target machine (DAW, MMC or P2). Its indicator lights up when Loop Playback is on. See "Using the Locator" on page 258 for more information.
- ⑭ **QUICK PUNCH button**

This button is used to turn on and off the Quick Punch function on the target machine (DAW, MMC or P2). Its indicator lights up when Quick Punch is on. See "Using the Locator" on page 258 for more information.
- ⑮ **ROLL BACK button**

This button is used to roll back (i.e., rewind) the target machine (MMC or P2) from the current position by a predefined amount. Its indicator lights up momentarily when it's pressed. See "Using the Locator" on page 258 for more information.

**⑩ REHEARSAL button**

This button is used to turn on and off the Rehearsal function on the target machine (MMC or P2). Its indicator lights up when Rehearsal is on. See “Using the Locator” on page 258 for more information.

**⑪ MASTER button**

This button is used to select the Master machine for Locator, Transport, Scrub, and Shuttle control. Its indicator lights up when Master is selected (the [MTR] button indicator goes off). See “Using the Locator” on page 258 for more information.

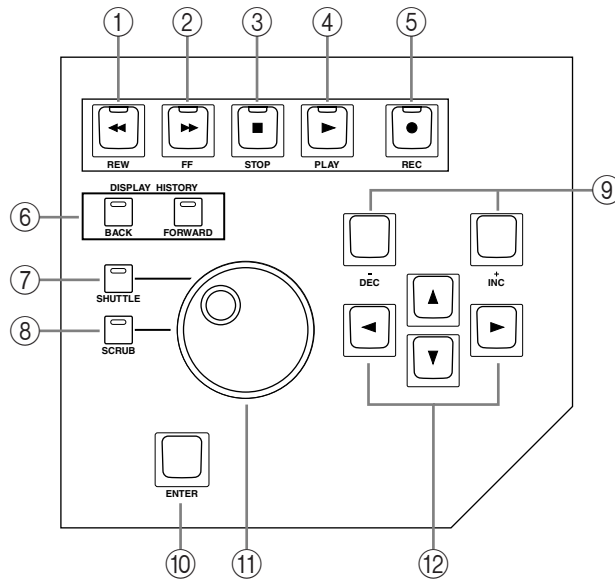
**Data Entry & Transport****① REW button**

This button starts rewind on the target machine (DAW, MMC or P2). Its indicator lights up while rewinding is in progress. See “Transport Buttons” on page 257.

**② FF button**

This button starts fast forward on the target machine (DAW, MMC or P2). Its indicator lights up while fast forwarding is in progress. See “Transport Buttons” on page 257.

**③ STOP button**

This button stops the target machine (DAW, MMC or P2). Its indicator lights up momentarily when it’s pressed. See “Transport Buttons” on page 257.

**④ PLAY button**

This button starts playback on the target machine (DAW, MMC or P2). Its indicator lights up while playback is in progress. See “Transport Buttons” on page 257.

**⑤ REC button**

This button is used in conjunction with the [PLAY] button to start recording on the target machine (DAW, MMC or P2). Its indicator lights up while recording is in progress. See “Transport Buttons” on page 257.

**⑥ DISPLAY HISTORY BACK/FORWARD buttons**

These buttons work like the back and forward buttons on a Web browser, allowing you to return to recently displayed pages. See “Display History” on page 53 for more information.

**⑦ SHUTTLE button**

This button is used to set the Parameter wheel to Shuttle mode for machine control (DAW, MMC or P2). Its indicator lights up when Shuttle mode is on. See “Using Shuttle & Scrub” on page 258 for more information.

**⑧ SCRUB button**

This button is used to set the Parameter wheel to Scrub mode for machine control (DAW, MMC or P2). Its indicator lights up when Scrub mode is on. See “Using Shuttle & Scrub” on page 258 for more information.

**⑨ DEC & INC buttons**

These buttons are used to adjust parameter values. Pressing the [INC] button increases the value of the currently selected parameter by one. Pressing the [DEC] decreases it. Pressing and holding either button causes the parameter value to change continuously.

These buttons can also be used to set on/off-type parameters, such as EQ ON/OFF. When such a parameter is selected, pressing the [DEC] button turns the function off, pressing the [INC] button turns it on.

These buttons can also be used to scroll through Scene and library lists.

**⑩ ENTER button**

This button is used to select and finalize parameter settings, to set on/off-type parameters, such as EQ ON/OFF, and to enter characters when titling Scenes, Effects, and so on. When a Pan control is selected on a Pan display page, pressing this button resets the pan position to center. For certain parameters, the [ENTER] button supports double clicking (i.e., two quick presses).

**⑪ Parameter wheel**

The Parameter wheel is used to edit parameter values, scroll through Scene and library lists, and to position the cursor when titling Scenes, Effects, and so on. Its detented action gives it a positive feel, allowing quick and accurate parameter editing. Turning it clockwise increases parameter values; turning it counterclockwise decreases them. Turning it fast allows quick parameter editing.

The Parameter wheel is also used with the Shuttle and Scroll functions. See “Using Shuttle & Scrub” on page 258 for more information.

**⑫ Cursor buttons**

These buttons are used to move the cursor around the display pages, selecting parameters and options. The cursor appears as a flashing box, making it easy to see which parameter or option is currently selected. Holding down a cursor button moves the cursor continuously in the respective direction.



## Monitor, Phones & Talkback Section

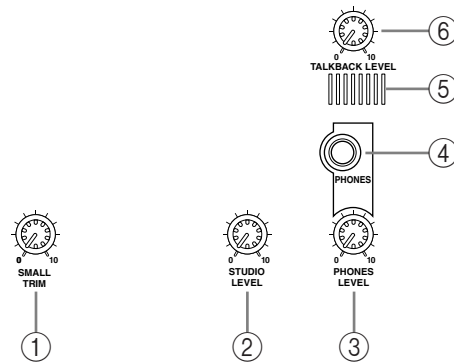

① **SMALL TRIM control**

This control is used to set the level of the SMALL CONTROL ROOM MONITOR OUT. See “Control Room Monitoring” on page 158 for more information.

② **STUDIO LEVEL control**

This control is used to set the level of the STUDIO MONITOR OUT. See “Studio Monitoring” on page 159 for more information.

③ **PHONES LEVEL control**

This control is used to set the level of the PHONES. See “Control Room Monitoring” on page 158 for more information.

④ **PHONES jack**

This stereo TRS phone jack outputs the Control room signal for monitoring via a pair of stereo headphones.

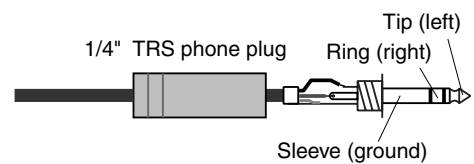

⑤ **Talkback mic**

This built-in microphone is used for talkback. See “Using Talkback & Slate” on page 163 for more information.

⑥ **TALKBACK LEVEL control**

This control is used to set the level of the built-in talkback microphone. See “Using Talkback & Slate” on page 163 for more information.

## MONITOR Section

The various subsections of the MONITOR section are explained below.

### STUDIO

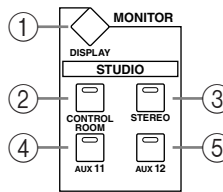
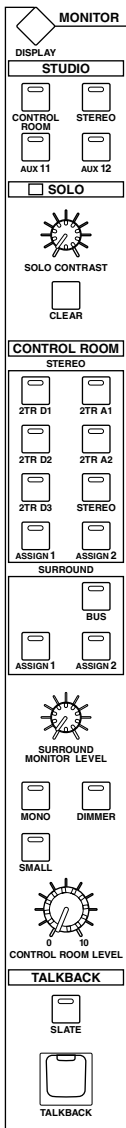

① **MONITOR DISPLAY button**

This button is used to select the following pages: Solo Setting, Control Room Setup, Talkback Setup, Surround Monitor, Surround Monitor Setup, Surround Monitor Patch, and Surround Monitor Library. See “Configuring Solo” on page 143, “Control Room Monitoring” on page 158 “Using Talkback & Slate” on page 163, and “Surround Monitoring” on page 160 respectively for more information.

② **CONTROL ROOM button**

This button selects the Control Room Monitor signal as the Studio Monitor signal source. Its indicator lights up when this source is selected. See “Studio Monitoring” on page 159 for more information.

③ **STEREO button**

This button selects the Stereo Out signal as the Studio Monitor signal source. Its indicator lights up when this source is selected. See “Studio Monitoring” on page 159 for more information.

④ **AUX 11 button**

This button selects Aux Send #11 as the Studio Monitor signal source. Its indicator lights up when this source is selected. See “Studio Monitoring” on page 159 for more information.

⑤ **AUX 12 button**

This button selects Aux Send #12 as the Studio Monitor signal source. Its indicator lights up when this source is selected. See “Studio Monitoring” on page 159 for more information.

### SOLO

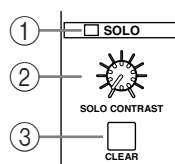

① **SOLO indicator**

This indicator flashes when one or more Channels are soloed, indicating that the Solo function is active. See “Soloing Channels” on page 142 for more information.

② **SOLO CONTRAST control**

This control is used to set the level balance between soloed Input Channels and the currently selected CONTROL ROOM source. It has no effect on soloed Output Channels. See “Soloing Channels” on page 142 for more information.

③ **CLEAR button**

This button can be used to unsolo all soloed Channels. See “Soloing Channels” on page 142 for more information.

## CONTROL ROOM

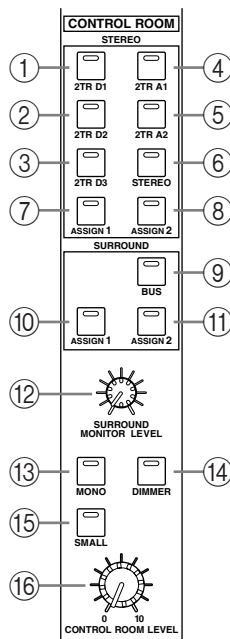
① **STEREO 2TR D1 button**

This button selects the 2TR IN DIGITAL AES/EBU 1 as the Control Room Monitor signal source. Its indicator lights up when this source is selected. See “Control Room Monitoring” on page 158 for more information.

② **STEREO 2TR D2 button**

This button selects the 2TR IN DIGITAL AES/EBU 2 as the Control Room Monitor signal source. Its indicator lights up when this source is selected. See “Control Room Monitoring” on page 158 for more information.

③ **STEREO 2TR D3 button**

This button selects the 2TR IN DIGITAL COAXIAL 3 as the Control Room Monitor signal source. Its indicator lights up when this source is selected. See “Control Room Monitoring” on page 158 for more information.

④ **STEREO 2TR A1 button**

This button selects the 2TR IN ANALOG 1 as the Control Room Monitor signal source. Its indicator lights up when this source is selected. See “Control Room Monitoring” on page 158 for more information.

⑤ **STEREO 2TR A2 button**

This button selects the 2TR IN ANALOG 2 as the Control Room Monitor signal source. Its indicator lights up when this source is selected. See “Control Room Monitoring” on page 158 for more information.

⑥ **STEREO button**

This button selects the Stereo Out as the Control Room Monitor signal source. Its indicator lights up when this source is selected. See “Control Room Monitoring” on page 158 for more information.

⑦ **STEREO ASSIGN 1 button**

This button is used to select the assigned Output Channel as the Control Room Monitor signal source. Its indicator lights up when this source is selected. See “Control Room Setup” on page 159 for more information.

⑧ **STEREO ASSIGN 2 button**

This button is used to select the assigned Output Channel as the Control Room Monitor signal source. Its indicator lights up when this source is selected. See “Control Room Setup” on page 159 for more information.

⑨ **SURROUND BUS button**

This button is used to select the Bus Outs as the Surround Monitor signal source. Its indicator lights up when this source is selected. See “Surround Monitoring” on page 160 for more information.

⑩ **SURROUND ASSIGN 1 button**

This button is used to select the assigned Slot’s Inputs as the Surround Monitor signal source. Its indicator lights up when this source is selected. See “Surround Monitoring” on page 160 for more information.

⑪ **SURROUND ASSIGN 2 button**

This button is used to select the assigned Slot’s Inputs as the Surround Monitor signal source. Its indicator lights up when this source is selected. See “Surround Monitoring” on page 160 for more information.

⑫ **SURROUND MONITOR LEVEL control**

This control is used to adjust the level of the Surround Monitor signals. See “Surround Monitoring” on page 160 for more information.

**⑬ MONO button**

This button is used to switch the Control Room Monitor signal into mono. Its indicator lights up when mono is selected. See “Control Room Monitoring” on page 158 for more information.

**⑭ DIMMER button**

This button is used to dim the Control Room Monitor and Surround Monitor signals. Its indicator lights up when these signals are dimmed. See “Control Room Monitoring” on page 158 for more information.

**⑮ SMALL button**

This button is used to route the Control Room Monitor signal to either the SMALL or LARGE CONTROL ROOM MONITOR OUTs. When it's off (indicator off), the signal is routed through to the LARGE CONTROL ROOM MONITOR OUTs, and when it's on (indicator on), the signal is routed through to the SMALL CONTROL ROOM MONITOR OUTs. See “Control Room Monitoring” on page 158 for more information.

**⑯ CONTROL ROOM LEVEL control**

This control is used to adjust the level of the Control Room Monitor signal. See “Control Room Monitoring” on page 158 for more information.

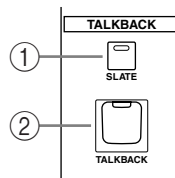
**TALKBACK****① SLATE button**

This button turns on the Slate function, which distributes the Talkback mic signal to all Bus Outs, Matrix Sends, and the Stereo Out. See “Using Talkback & Slate” on page 163 for more information.

**② TALKBACK button**

This button turns on the Talkback function, which distributes the Talkback mic signal to the Studio Monitor Outs, any Slot and Omni Outputs specified on the Talkback Setup page. See “Using Talkback & Slate” on page 163 for more information.

# Rear Panel

AD Input Section (p. 46)

Analog Master I/O Section (p. 46)

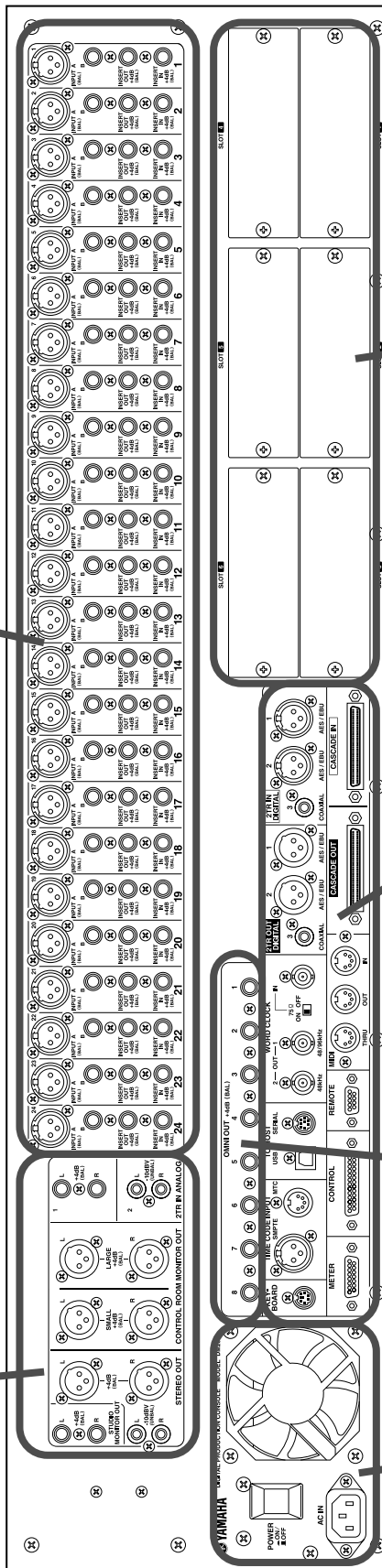

OMNI OUT Section (p. 47)

Power Section (p. 50)

Digital I/O & Control Section (p. 48)

SLOT Section (p. 50)

### AD Input Section

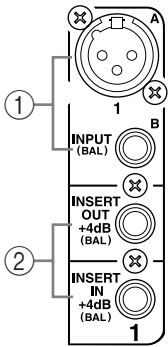

① **INPUT A & B (BAL) connectors**

AD Inputs 1 through 24 feature balanced XLR-3-31-type connectors and balanced 1/4-inch phone jacks, both with a nominal input range of  $-60$  dB to  $+10$  dB. Phantom powering ( $+48$  V) is supplied to the XLR-type connectors, with individual ON/OFF switches on each input. The phone jacks, which can also be used with unbalanced phone plugs, have priority over the XLR-type connectors, so when a phone plug is inserted, the XLR-type connector is disconnected. These inputs can be patched individually to the Input Channels or Insert Ins. With their high sensitivity and PAD switches, these inputs can handle a wide range of signals, from condenser microphones to “hot” line levels. See “AD Input Section” on page 64 for more information.

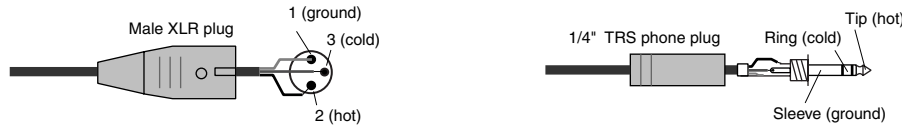

② **INSERT IN & OUT +4dB (BAL) connectors**

These balanced 1/4-inch TRS phone jacks are used to insert external signal processors, etc., into AD Inputs 1 through 24. They are wired: sleeve-ground, ring-cold, tip-hot. The nominal signal level of both jacks is  $+4$  dB. Inserts can be turned on and off individually by using the INSERT ON/OFF switches. See “AD Input Section” on page 64 for more information.

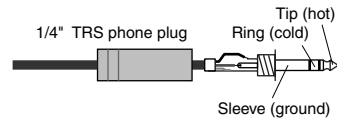

### Analog Master I/O Section

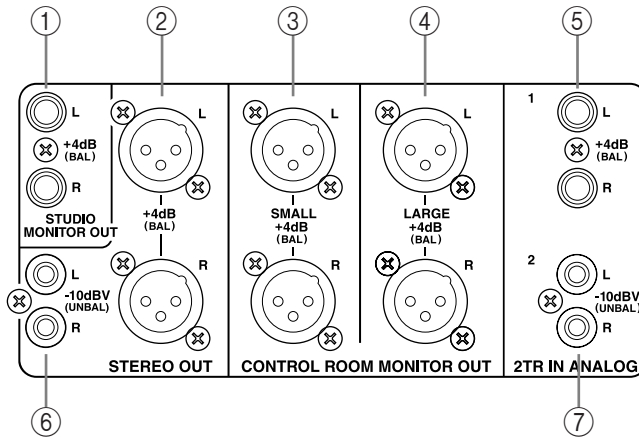

① **STUDIO MONITOR OUT +4 dB (BAL)**

These balanced 1/4-inch TRS phone jacks, nominal output level  $+4$  dB, output the analog Studio Monitor signal for monitoring in the actual studio. The source, which is selected by using the STUDIO buttons in the MONITOR section, can be Aux Send #11, Aux Send #12, the Stereo Out, or Control Room. The output level is controlled by the STUDIO LEVEL control. See “Studio Monitoring” on page 159 for more information.

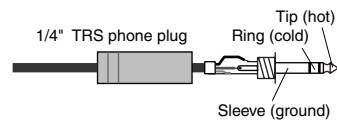

② **STEREO OUT +4 dB (BAL)**

These balanced XLR-3-32-type connectors, nominal output level +4 dB, output the analog Stereo Out signal and are typically connected the stereo inputs of a 2-track recorder. They are wired pin 1–ground, pin 2–hot (+), and pin 3–cold (–). See “Stereo Out Connectors” on page 104.

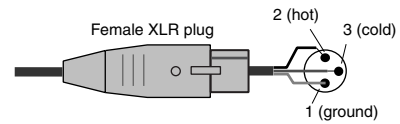

③ **SMALL CONTROL ROOM MONITOR OUT +4 dB (BAL)**

These balanced XLR-3-32-type connectors, nominal output level +4 dB, output the analog Small Control Room Monitor signal and are typically used to feed the control room’s nearfield monitors. See “Control Room Monitoring” on page 158 for more information.

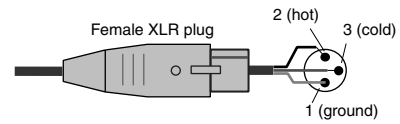

④ **LARGE CONTROL ROOM MONITOR OUT +4 dB (BAL)**

These balanced XLR-3-32-type connectors, nominal output level +4 dB, output the analog Large Control Room Monitor signal and are typically used to feed the control room’s main monitors. See “Control Room Monitoring” on page 158 for more information.

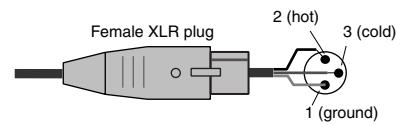

⑤ **2TR IN ANALOG 1 +4 dB (BAL)**

These balanced 1/4-inch TRS phone jacks, nominal input level +4 dB, are typically used to connect the analog stereo outputs of a 2-track recorder. Signals connected here can be monitored via the CONTROL ROOM MONITOR OUT by pressing the CONTROL ROOM [2TR A1] button. In addition, this input can be patched to Input Channels or Insert Ins. See “2TR Analog INs” on page 65.

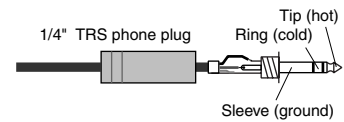

⑥ **STEREO OUT –10 dBV (UNBAL)**

These unbalanced phono connectors, nominal output level –10 dBV, output the analog Stereo Out signal and are typically connected to the stereo inputs of a 2-track recorder. See “Stereo Out Connectors” on page 104.

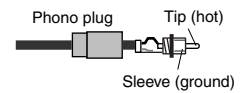

⑦ **2TR IN ANALOG 2 –10 dBV (UNBAL)**

These unbalanced phono connectors, nominal input level –10 dBV, are typically used to connect the analog stereo outputs of a 2-track recorder. Signals connected here can be monitored via the CONTROL ROOM MONITOR OUTs by pressing the CONTROL ROOM [2TR A2] button. In addition, this input can be patched to Input Channels or Insert Ins. See “2TR Analog INs” on page 65.

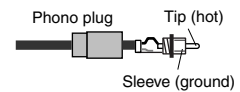

**OMNI OUT Section**

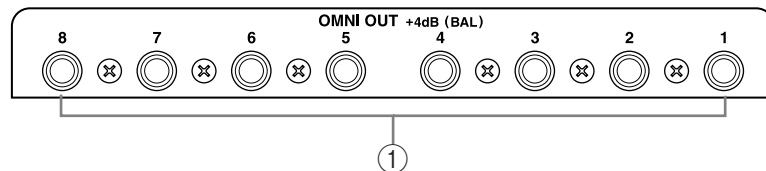

① **OMNI OUT +4dB (BAL)**

These balanced 1/4-inch TRS phone jacks, nominal output level +4 dB, provide eight analog outputs that can be patched to the following: Bus Outs, Aux Sends, Matrix Sends, the Stereo Out, Insert Outs, Direct Outs, or Surround Monitor Channels. See “Omni Outs” on page 65.

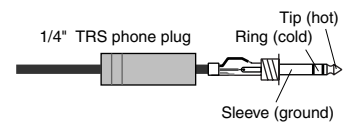

## Digital I/O & Control Section

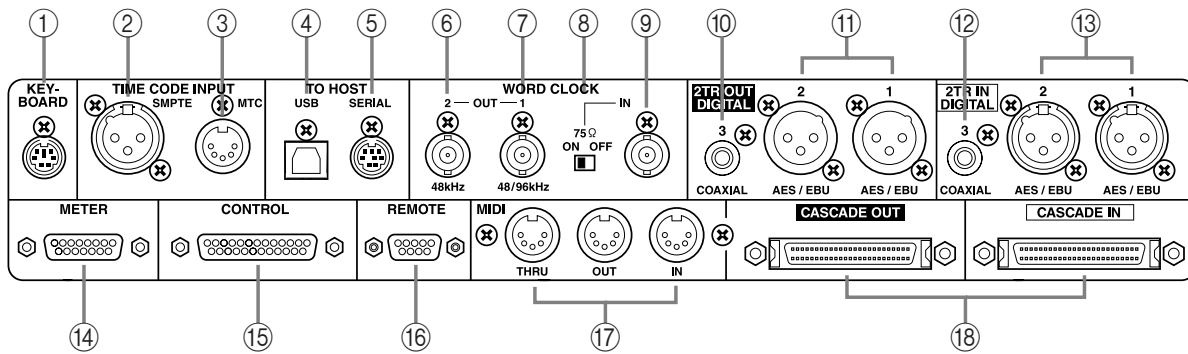

- ① **KEYBOARD connector**  
A PS/2 compatible keyboard can be connected here for quick entry of scene and library titles and channel names. See “Using a Keyboard” on page 55 for more information.
- ② **SMPTE TIME CODE INPUT connector**  
This balanced XLR-3-31-type connector is used to input SMPTE timecode for synchronizing the Automix function. See “Selecting the Timecode Source & Frame Rate” on page 201.
- ③ **MTC TIME CODE INPUT connector**  
This 5-pin DIN connector is used to input MTC for synchronizing the Automix function. See “Selecting the Timecode Source & Frame Rate” on page 201.
- ④ **USB TO HOST port**  
This USB port is for MIDI communication between the DM2000 and a host computer with a USB port. See “MIDI I/O” on page 215 for more information.
- ⑤ **SERIAL TO HOST port**  
This 8-pin mini DIN port is for MIDI communication between the DM2000 and a host computer with a serial port. See “MIDI I/O” on page 215 for more information.
- ⑥ **WORD CLOCK OUT 2 connector**  
This BNC connector outputs a wordclock signal at half the clock rate of the DM2000 when using 88.2 kHz or 96 kHz. See “Wordclock Connections” on page 66 for more information.
- ⑦ **WORD CLOCK OUT 1 connector**  
This BNC connector outputs a wordclock signal at the same clock rate as the DM2000. See “Wordclock Connections” on page 66 for more information.
- ⑧ **WORD CLOCK 75Ω ON/OFF termination switch**  
This switch applies 75Ω termination to the WORD CLOCK IN. See “Terminating External Wordclocks” on page 68 for more information.
- ⑨ **WORD CLOCK IN connector**  
This BNC connector is for connecting an external wordclock signal. See “Selecting the Wordclock Source” on page 67 for more information.
- ⑩ **2TR OUT DIGITAL COAXIAL 3**  
This phono connector outputs consumer format (IEC-60958) digital audio, and is typically connected to the digital stereo input of a 2-track recorder. The following signals can be patched to this output: Stereo Out, Bus Outs, Aux Sends, Matrix Sends, Direct Outs, Insert Outs, and Control Room. The sampling rate of the digital audio output can be set independently of the DM2000 sampling rate by using the internal sampling rate converter. Dither can be applied for digital audio transfer to lower-resolution systems. See “2TR Digital Outs” on page 68 for more information.



**⑪ 2TR OUT DIGITAL AES/EBU 1 & 2**

These XLR-3-32-type connectors output AES/EBU format digital audio, and are typically connected to the digital stereo inputs of 2-track recorders. The following signals can be patched to these outputs: Stereo Out, Bus Outs, Aux Sends, Matrix Sends, Direct Outs, Insert Outs, and Control Room. The sampling rate of the digital audio output can be set independently of the DM2000 sampling rate by using the internal sampling rate converters. Dither can be applied for digital audio transfer to lower-resolution systems. See “2TR Digital Outs” on page 68 for more information.

**⑫ 2TR IN DIGITAL COAXIAL 3**

This phono connector accepts consumer format (IEC-60958) digital audio, and is typically used to connect the digital stereo output of a 2-track recorder. Signals connected here can be monitored via the CONTROL ROOM MONITOR OUT by pressing the CONTROL ROOM [2TR D3] button. In addition, this input can be patched to Input Channels or Insert Ins. Unsynchronized digital audio signals can be converted by the internal sampling rate converters. See “2TR Digital Ins” on page 69 for more information.

**⑬ 2TR IN DIGITAL AES/EBU 1 & 2**

These XLR-3-31-type connectors accept AES/EBU format digital audio, and are typically used to connect the digital stereo outputs of 2-track recorders. Signals connected here can be monitored via the CONTROL ROOM MONITOR OUT by pressing the CONTROL ROOM [2TR D1] button or [2TR D2] button. In addition, these inputs can be patched to Input Channels or Insert Ins. Unsynchronized digital audio signals can be converted by the internal sampling rate converters. See “2TR Digital Ins” on page 69 for more information.

**⑭ METER port**

This 15-pin D-sub connector is for connecting the optional MB2000 Peak Meter Bridge.

**⑮ CONTROL port**

This 25-pin D-sub connector provides access to the GPI (General Purpose Interface) through which external equipment can be triggered when specified DM2000 faders or USER DEFINE KEYS are operated. It can also be used to control a “RECORDING” light outside of a studio, to trigger the Solo function of an 02R Digital Recording Console, or to turn on Talkback from an external device. See “GPI (General Purpose Interface)” on page 264 for more information.

**⑯ REMOTE port**

This 9-pin D-sub connector can be used to connect an optional Yamaha AD8HR/AD824 AD Converter, providing remote and recallable control of its head amp settings. Machines that support the Sony P2 protocol can also be controlled from the DM2000 via this port. A straight cable should be used to connect a P2 device; a reversed cable for an AD8HR/AD824. See “Controlling AD8HR/AD824 A/D Converters” on page 267 and “About Machine Control (MMC & P2)” on page 256 for more information.

**⑰ MIDI IN, OUT & THRU ports**

These standard MIDI IN, OUT, and THRU ports are used to connect the DM2000 to other MIDI equipment. Supported MIDI messages include Program Changes for Scene recall, Control Changes and Parameter Changes for real-time parameter control, Bulk Dump for data storage, MIDI Clock, MTC, and MMC. See “MIDI I/O” on page 215 for more information.

**⑱ CASCADE IN & OUT ports**

These 64-pin connectors can be used to cascade up to four DM2000s to create a multiple-unit mixing system. The DM2000 can also be cascaded with an 02R Digital Recording Console. See “Cascading Consoles” on page 74 for more information.

## Power Section

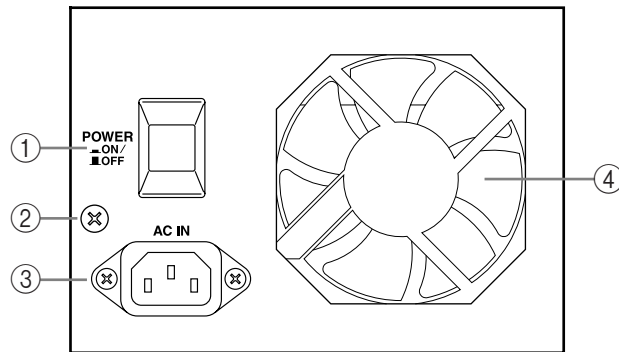

- ① **POWER ON/OFF switch**  
This switch is used to turn on the power to the DM2000. See “Turning On & Off the DM2000” on page 51 for more information.
- ② **Grounding screw**  
For electrical safety reasons, and correct operation of the touch-sensitive faders, it’s important that the DM2000 is grounded properly. The supplied power cord has a three-pin plug, and if the ground terminal of the AC outlet is grounded, then the unit will be grounded sufficiently through the power cord. If the AC outlet does not provide a suitable ground, this screw must be connected to a suitable ground point. Grounding is also an effective method for eliminating hum, interference, and other noise.
- ③ **AC IN connector**  
This connector is used to connect the DM2000 to an AC outlet via the supplied power cord. See “Connecting the Power Cord” on page 51 for more information.
- ④ **Cooling fan**  
The cooling fan expels air out through this outlet. If the airflow is restricted, the DM2000 may overheat, so make sure this outlet is not blocked.

## SLOT Section

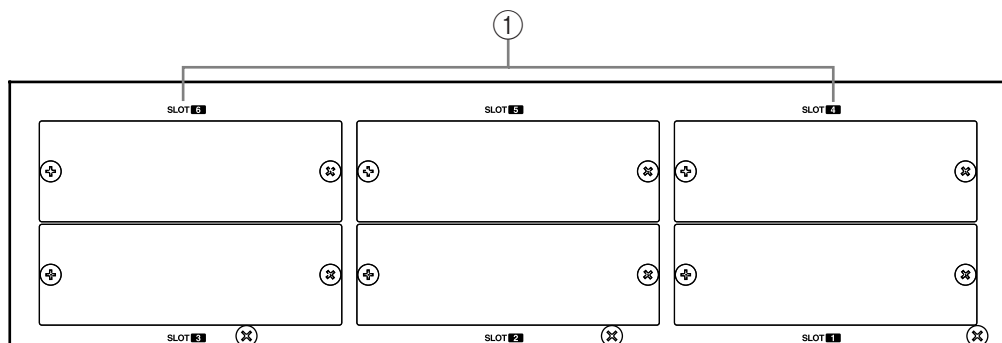

- ① **SLOT 1–6**  
These six slots are for use with optional mini YGDAI cards, which offer a variety of analog and digital I/O options. See “Slot I/O” on page 70 for more information. Slot inputs can be patched to Input Channels or Insert Ins. See “Input Patching” on page 77 for more information. The following signals can be patched to the Slot Outputs: Bus Outs, Aux Sends, Matrix Sends, Stereo Out, Insert Outs, Direct Outs, and Surround Monitor Channels. See “Output Patching” on page 79 for more information.

## 3 Operating Basics

### Connecting the Power Cord

*Warning: Turn off all equipment connected to the DM2000 before making any power connections.*

Connect the socket-end of the supplied power cord to the AC IN on the rear panel of the DM2000. Connect the plug-end to a suitable AC wall outlet, one that conforms to the power supply requirements stated on the DM2000's rear panel.

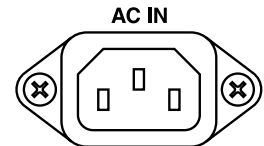

### Turning On & Off the DM2000

To prevent loud clicks and thumps in your speakers, turn on your audio equipment in the following order (reverse this order when turning off)—sound sources, multitrack and master recorders, DM2000, monitoring power amplifiers.

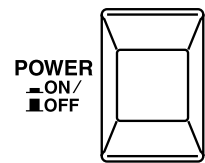

- 1 To turn on the DM2000, press the [POWER] switch.

The startup page appears for a while, and then the last selected display page appears.

- 2 To turn off the DM2000, press the [POWER] switch again.

## About the Display

All DM2000 mix parameters can be edited on the various display pages.

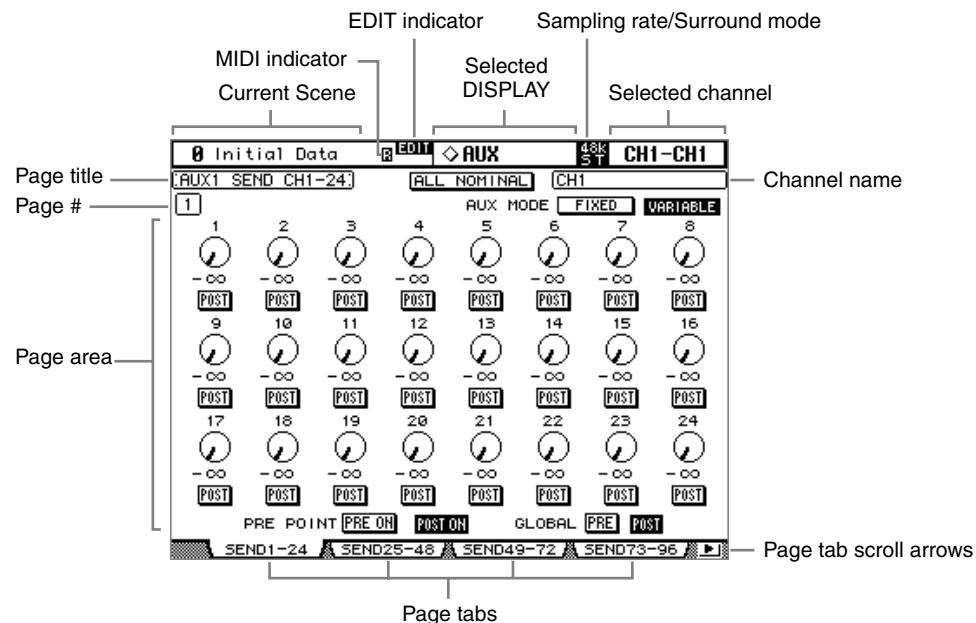

**Current Scene:** The number and title of the currently selected Scene memory are displayed here. See “Storing & Recalling Scenes with the SCENE MEMORY Buttons” on page 187 for more information. If the selected Scene is write-protected, a padlock icon appears. See “Using the Scene Memory Page” on page 188 for more information.

**MIDI indicator:** This indicator appears when the DM2000 is receiving MIDI data via the MIDI IN port, USB TO HOST port, or SERIAL TO HOST port.

**EDIT indicator:** This indicator appears when the current mix settings no longer match those of the Scene that was recalled last. It works in unison with the Edit indicator dot on the SCENE MEMORY display. See “Edit Buffer & Edit Indicator” on page 185 for more information.

**Selected DISPLAY:** This indicates the currently selected display page group, for example, AUX, EQ, or AUTOMIX. Display page groups are selected by using the [DISPLAY] buttons.

**Sampling rate/Surround mode:** This indicates the current sampling rate—44.1 kHz (44k), 48 kHz (48k), 88.2 kHz (88k), or 96 kHz (96k), and surround mode—6.1, 5.1, 3-1, and ST.

**Selected channel:** The Input or Output Channel currently selected by the [SEL] buttons is indicated here. See “Selecting Channels” on page 59. The first four characters are the Channel ID (e.g., CH1–CH96, BUS1–BUS8, AUX1–AUX9, AX10–AX12, MT1L–MT4R, ST-L, ST-R). The second four, are the channel’s Short name. See “Naming Channels” on page 156.

**Channel name:** Depending on the currently selected page, this is the Long name of either the currently selected channel or the channel selected by the cursor buttons. On some pages, the Aux Send pages, for example, it’s possible to edit Aux Send levels without having to select each Input Channel. Instead, Input Channel Aux Sends can be selected by using the cursor buttons. In this case, the name displayed here is different to the name displayed in the upper-right corner of the display.

**Page title:** This is the title of the currently selected page.

**Page #:** Depending on the group of pages currently selected, page numbers are displayed here. For example, although you can view only one Input Channel 1–24 Aux Send page at a time, there are in fact 12 Input Channel 1–24 Aux Send pages, one for each of the 12 Aux Sends. Page numbers are also displayed when the following page groups are selected: Matrix Sends, Effects, and GEQ.

**Page area:** This area of the display is where the various display pages appear.

**Page tabs:** These tabs are used when selecting pages. Up to four tabs are visible at a time. See “Selecting Display Pages” on page 53 for more information.

**Page tab scroll arrows:** These arrows indicate that there are more pages available. See “Selecting Display Pages” on page 53 for more information.

## Selecting Display Pages

 Display pages are grouped by function, and each group of pages can be selected by using the following [DISPLAY] buttons: MATRIX SELECT, AUX SELECT, ENCODER MODE, EFFECTS/PLUG-INS, ROUTING, PHASE/INSERT, DELAY, AUX/MATRIX SEND, DYNAMICS, PAN/SURROUND, EQUALIZER, TRACK ARMING, SCENE MEMORY, AUTOMIX, USER DEFINED KEYS, LOCATOR, MONITOR. Further page groups can be selected by using the DISPLAY ACCESS buttons.

- The next page in the group can be selected by pressing the [DISPLAY] button.
- Previous pages can be selected by pressing and holding down the [DISPLAY] button.
- The first page in the group can be selected by double-clicking the [DISPLAY] button.
- Pages whose tabs are currently displayed can be selected by using the F1–F4 buttons.

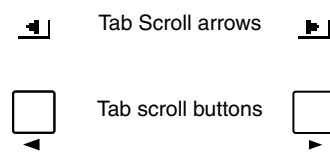

If there are more pages available than the four whose tabs are currently displayed, depending on whether they are located to the left or right, either the left or right Tab Scroll arrow appears. Pressing either the Left or Right Tab Scroll button displays the tabs of these pages, which can then be selected by using the F1–F4 buttons.

When parameters are divided among several pages, for example, the Input Channel Attenuators, which are divided among four pages, the page containing the parameter for the currently selected channel is selected automatically when channels on different Layers are selected. For example, if the Input Channel 1–24 Attenuator page is currently selected, and then you select, say, Input Channel #25 by using the LAYER [25–48] button and [SEL] button #1, the Input Channel 25–48 Attenuator page is selected automatically.

The currently selected page in a group, and the parameter selected on that page, are remembered when you select another group of pages, so when you return to that group, by pressing its [DISPLAY] button, that page is displayed with the same parameter selected.

The Auto Display preferences can be set so that certain pages appear automatically when a corresponding control is adjusted. For example, if the “Auto EQUALIZER Display” preference is on, the EQ page appears automatically when a SELECTED CHANNEL EQUALIZER control is operated. See page 274 for information on the Auto Display preferences.

## Display History

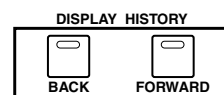

The Display History function works like the history function on a Web browser, and allows you to return quickly to up to eight recently displayed pages. Each time you view a page for more than five seconds, it’s added to the Display History buffer.

Pressing the DISPLAY HISTORY [BACK] button selects the previous page in the buffer. Pressing the DISPLAY HISTORY [FORWARD] button selects the next page in the buffer. If there are no pages in the buffer, nothing happens when these buttons are pressed.

You can scroll forwards or backwards through all the pages in the buffer by pressing and holding the [BACK] or [FORWARD] button respectively. Scrolling like this continuously cycles through all the pages in the buffer. You can clear the Display History buffer by pressing the [BACK] and [FORWARD] buttons simultaneously.

## Display Page Controls

Operation of the various buttons, rotary controls, and faders that appear on the display pages is straightforward. The only items that require a special mention are the parameter boxes, such as the GEQ Insert parameter box shown here. Operation of these boxes consists of two steps. First you select a value, typically by using the Parameter wheel or INC/DEC buttons. Second you confirm your selection, while the value is flashing, by pressing the [ENTER] button. If you select another parameter while the value is still flashing, it remains unchanged.

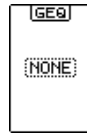

## Parameter Windows

When a rotary control in the SELECTED CHANNEL section is operated, if the corresponding parameter does not appear on the currently selected page, a parameter window like the one shown here is displayed while the control is adjusted. If the control is not adjusted for awhile, the window closes automatically. If the Auto Display preference for the adjusted parameter is on, the page containing that parameter appears instead of this parameter window.



## Confirmation Messages

For certain functions, the DM2000 prompts you for confirmation before executing them, as shown here. Press YES to execute the function, or press NO to cancel. If no action is taken for awhile, the confirmation window closes automatically and the function is not executed.

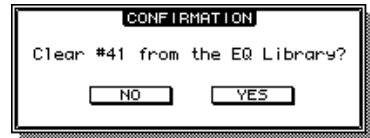

## Title Edit Window

The Title Edit window is used to enter titles for Scene and library memories, automixes, and so on. Depending on the item being titled, the number of characters that can be entered is either 4, 12, or 16. The following screen shots show the available characters. The one on the left shows uppercase characters and various punctuation marks. That on the right, lowercase characters and numbers.

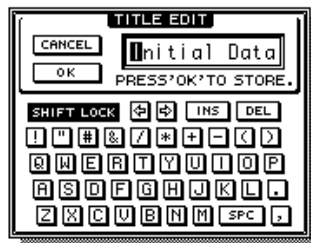

Use the cursor buttons to select characters, and the [ENTER] button to enter them into the title. The cursor moves to the right automatically as each character is entered. The Parameter wheel or the arrow buttons can be used to move the cursor within the title.

Use the SHIFT LOCK button to select uppercase and lowercase characters, and use the SPC button to enter a space. To insert a space at the cursor position and move subsequent characters to the right, press the INS button. To delete the character at the cursor position, press the DEL button.

When you've finished, press the OK button to enter the title, or press CANCEL to cancel title entry.

## Using a Keyboard

A PS/2 compatible keyboard can be connected to the KEYBOARD port and used for quick title entry while the Title Edit window is displayed. Note that only 101 and 104-key U.S. keyboards are supported.

Characters, including letters, numbers, and punctuation marks, supported by the DM2000 can be entered. Characters appear directly in the Title Edit window, the same as when they are entered on the DM2000. The following table shows how other keys correspond to Title Edit window functions.

KEYBOARD



Key	Title Edit Window function	Description
ESC	CANCEL	Cancels title entry
RETURN/ENTER	OK	Enters the specified title
CAPS LOCK	SHIFT LOCK	Toggles between uppercase and lowercase
SHIFT	—	Switches to uppercase characters
Backspace	—	Deletes the character to the left
Cursor (left/right)	Left/right arrow buttons	Moves the cursor within the title
INSERT	INS	Toggles between insert and overwrite modes
DELETE	DEL	Deletes the selected character
SPACE bar	SPACE	Inserts a space at the current position

## Channel Strip Displays

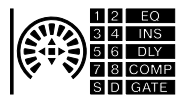

CH01

The fluorescent channel strip displays show information regarding the channel strips, as described below.

You can adjust their brightness by using the Channel Strip Display Brightness preference on page 277.

### Selected Channel



The border of the currently selected channel's channel strip display lights up like this.

### Fader Touch Sense



When fader knobs are touched, the corresponding Touch Sense indicators light up like this.

### Routing Indicators

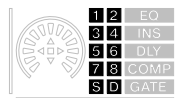

These indicators show to which Output Channels an Input Channel is being routed: 1 through 8 being the Bus Outs, "S" being the Stereo Out, and "D," the Direct Out.

### EQ, Insert, Delay, Comp & Gate Indicators

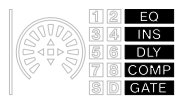

These indicators show whether a channel's EQ, Insert, Delay, Comp, and Gate functions are on or off.

### Encoder Displays



Operation of the Encoder displays depends on the parameter assigned to the Encoders, as follows.

#### Pan Mode, Surround L/R, and Surround F/R position



Hard left  
(▲ indicates center position)



Other position



Center  
(■ indicates at center)



Hard right

#### Aux/Mtrx Mode and Alt Layer



Minimum (−∞)  
(▶ indicates nominal position)



Other position



Nominal  
(■ indicates at nominal)



Maximum

#### Surr LFE Level



Minimum (−96 dB)  
(▶ indicates nominal position)



Other position



Nominal  
(■ indicates at nominal)



Maximum

#### Attenuator Parameter



Minimum (−96 dB)  
(▶ indicates nominal position)



Other position



Nominal  
(■ indicates at nominal)



Maximum

#### Delay Feedback Gain, Delay Mix & EQ Gain Parameters



Negative value  
(▲ indicates 0%, ±0 dB)



0%, ±0 dB  
(■ indicates at 0%, ±0 dB)



Positive value

#### On/Off & Pre/Post Parameters

EQ On/Off, Phase On/Off, Insert On/Off, EQ Type, Gate On/Off, Comp On/Off, Aux Send Pre/Post.



On/Pre



Off/Post

#### Scene Fade Time Parameters



Minimum  
(Off when Fade Time is minimum)



Other value



Maximum



### Other Parameters

Delay Time, EQ Q, EQ Frequency, Comp Threshold, Comp Ratio, Comp Attack, Comp Release, Comp Out Gain, Comp Knee, Gate Threshold, Gate Range, Gate Attack, Gate Hold, Gate Decay, Comander Width, HA Input Gain, HA Insert In Gain.



Minimum



Other position



Other position



Maximum

### No Assign

When the Encoders are assigned to the No Assign, Input Patch, Insert In Patch, Insert Out Patch, Direct Out, or Surround Pan Wheel parameter, the Encoder displays are inactive.

### Channel Names

The channel strip displays also display the names or IDs of all the channels on the currently selected Layer. Each Input and Output Channel has a fixed Channel ID and Short and Long names that you can edit. See “Naming Channels” on page 156.

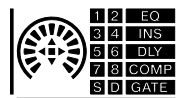

You can specify whether Short names or Channel IDs are displayed in the preferences. You can also choose whether Port names or Port IDs are displayed. See “Preferences 2” on page 276 for more information.

CH01

- To display a channel’s Long name, press and hold its [SEL] button.**

After about one second, the channel’s Short name, Long name, and Channel ID are displayed, as shown below.

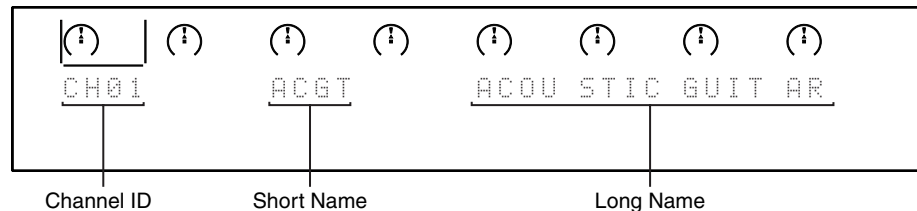

All other items in the displays are turned off while the [SEL] button is held down.

- Release the [SEL] button when you’ve finished.**

The channel strip displays return to normal.

### Channel Faders and Encoders

When you operate the channel faders, the corresponding levels are indicated in four digits on the channel strip displays. The displays return to the previous indication one second after you finish moving the faders.

If Pan, Aux Send, Matrix Send, or Alt Layer is assigned to the Encoders, four-digit parameter values appear on the channel strip displays when you operate the Encoders. The displays return to the previous indication one second after you finish operating the Encoders.

### Input Patch, Insert In Patch, Insert Out Patch & Direct Out

When the Input Patch, Insert In Patch, Insert Out Patch, or Direct Out parameter is assigned to the Encoders, the Encoder displays show Port IDs. See “Patching with the Encoders” on page 83 for more information.

## Selecting Layers

Input and Output Channels are arranged into Layers, as illustrated below. There are nine Layers altogether: four Input Channel Layers, one Master Layer (or Output Layer), and four Remote Layers.

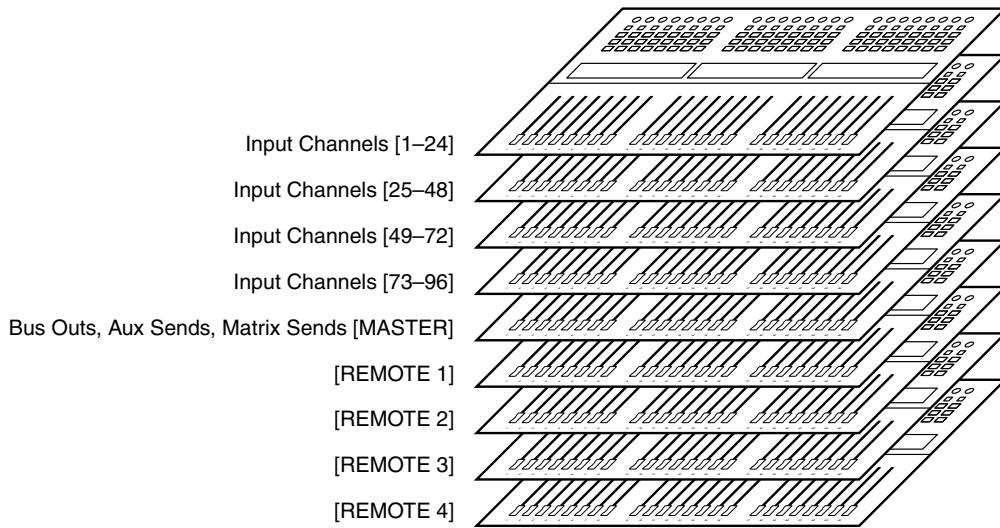

To select Input and Output Channels for editing with the channel strip controls, you use the LAYER buttons to select a Layer.

The LAYER button indicator for the currently selected Layer lights up, and the channel strip displays show the Short names/Channel IDs of the channels on the selected Layer.

The currently selected Layer determines the function of the channel strip Encoders, [AUTO] buttons, [SEL] buttons, [SOLO] buttons, [ON] buttons, channel strip displays, and faders. For example, when Layer 1–24 is selected, [SEL] button #1 controls Input Channel #1. When Layer 25–48 is selected, it controls Input Channel #25. And when the Master Layer is selected, it controls Bus Out #1.

The following table shows which Input and Output Channels are controlled by the channel strips for each Layer.

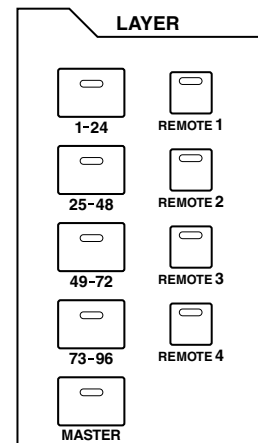

Layers	Channel Strips			
	1-8	9-16	17-20	21-24
1-24	Input Channels 1-24			
25-48	Input Channels 25-48			
49-72	Input Channels 49-72			
73-96	Input Channels 73-96			
MASTER	Bus Out masters 1-8	Aux Send masters 1-12	Matrix Send masters 1-4	
REMOTE 1-4	Operation depends on the selected target. See "About Remote Layers" on page 253 for more information.			

The exact function of each channel strip fader and Encoder also depends on the currently selected Fader mode and Encoder mode respectively. See "Selecting Fader Modes" on page 60 and "Selecting Encoder Modes" on page 61 for more information.

## Selecting Channels

To select Input and Output Channels for editing with the SELECTED CHANNEL controls, you use the LAYER buttons to select a Layer, and the [SEL] buttons to select a channel on that Layer.

- 1 **Select a Layer, as explained on page 58.**
- 2 **Use the [SEL] buttons to select an Input or Output Channel.**

The [SEL] button indicator for the currently selected channel lights up, and the border of its channel strip display lights up (see page 55). In addition, the Channel's ID and Short name appear in the upper right corner of the display (see page 52).



The exact channel selected by each [SEL] button depends on the currently selected Layer. For example, when Layer 1–24 is selected, [SEL] button #1 selects Input Channel #1. When Layer 25–48 is selected, it selects Input Channel #25. And when the Master Layer is selected, it selects Bus Out #1, as shown in the following table.

Layer	[SEL] Button			
	1–8	9–16	17–20	21–24
1–24	Input Channels 1–24			
25–48	Input Channels 25–48			
49–72	Input Channels 49–72			
73–96	Input Channels 73–96			
MASTER	Bus Outs 1–8	Aux Sends 1–12		Matrix Sends 1–4 <sup>1</sup>
REMOTE 1–4	Operation depends on the selected target. See “About Remote Layers” on page 253 for more information.			

1. Each time a [SEL] button is pressed, the selection toggles between the Matrix Send's left and right channels.

For paired Input or Output channels, the channel whose [SEL] button you press is selected, and its indicator lights up. The [SEL] button indicator of the other channel flashes.

Vertical and horizontal Input and Output channel partners can also be selected by using the SELECTED CHANNEL PAN/SURROUND [L] and [R] buttons, which can also be used to select left and right channels when a Matrix Send or the Stereo Out is selected.

If the currently displayed page contains a relevant parameter, when a channel's [SEL] button is pressed, the cursor moves to that parameter automatically. If the currently displayed page contains no such parameter, the page that does contain such a parameter is selected automatically. For example, if a Delay page for the Output Channels is selected when an Input Channel [SEL] button is pressed, the Delay page showing the relevant Input Channel Delay parameter is selected automatically.

## Stereo Out [SEL] Button

The Stereo Out [SEL] button is used exclusively to select the Stereo Out for editing with the SELECTED CHANNEL controls. Its indicator lights up when the Stereo Out is selected. Each time it's pressed, the selection toggles between the Stereo Out's left and right channels. The SELECTED CHANNEL PAN/SURROUND [L] and [R] buttons can also be used to select the left and right channels.

If the currently displayed page contains a Stereo Out parameter, that parameter is selected automatically when the Stereo Out [SEL] button is pressed. If the currently selected page contain no such parameter, the page that does contain such a parameter is selected automatically. For example, if a Delay page for the Input Channels is currently selected when the Stereo Out [SEL] button is pressed, the Delay page showing the Stereo Out Delay parameter is selected automatically.

## Auto Channel Select & Touch Sense Select

While the Auto Channel Select preference is on (see page 275), channels can be selected by moving the corresponding fader or Encoder, or by turning on the corresponding [AUTO], [SOLO], or [ON] button. Note that you can use the [AUTO] buttons to select channels only during Automix recording or in Automix record ready mode.

While the Fader Touch Sense SELECT preference is on (see page 276), channels can be selected simply by touching the fader knobs.

## Selecting Fader Modes

The exact function of each fader depends on the selected Layer and Fader mode.

- 1 **Select a Layer, as explained on page 58.**
- 2 **Use the FADER MODE buttons to select a Fader mode.**

**[FADER]:** Channel faders control Input Channel levels or Output Channel master levels, depending on the selected Layer.

**[AUX/MTRX]:** Channel faders control Aux or Matrix Send levels, depending on the selected Layer.

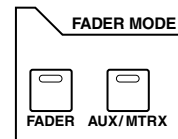

The indicator of the currently selected FADER MODE button lights up.

The following table shows the channel fader functions for each Layer and Fader mode.

Layer	Fader Mode	Fader			
		1-8	9-16	17-20	21-24
1-24	Fader	CH 1-24: level			
	Aux/Mtrx	CH 1-24: Aux Send level			
25-48	Fader	CH 25-48: level			
	Aux/Mtrx	CH 25-48: Aux Send level			
49-72	Fader	CH 49-72: level			
	Aux/Mtrx	CH 49-72: Aux Send level			
73-96	Fader	CH 73-96 level			
	Aux/Mtrx	CH 73-96: Aux Send level			
Master	Fader	Bus Out 1-8: master level	Aux Send 1-12: master level		Matrix Send 1-4: master level
	Aux/Mtrx	Bus Out 1-8: Matrix Send level	Aux Send 1-12: Matrix Send level		No operation: Faders fixed at $-\infty$
Remote 1-4	Fader	Operation depends on the selected target. See "About Remote Layers" on page 253 for more information.			
	Aux/Mtrx				

## Selecting Encoder Modes

The exact function of each Encoder depends on the selected Layer and Encoder mode. There are two preset Encoder modes, Pan and Aux/Mtrx, and four assignable modes, for which you can choose from over 40 parameters.



- 1 Select a Layer, as explained in page 58.
- 2 Use the ENCODER MODE buttons to select an Encoder mode.

**[PAN]:** Encoders function as Pan controls. When you press the Encoder push-switches, the current Pan positions appear on the channel strip displays.

**[AUX/MTRX]:** Encoders control Aux or Matrix Send levels, depending on the selected Layer. When you press the Encoder push-switches, the currently-selected Aux or Matrix Send levels appear on the channel strip displays.

**[ASSIGN 1–4]:** Encoders control the parameters assigned to the ASSIGN buttons. See “Assigning Parameters to the ENCODER MODE Assign Buttons” on page 62 for more information.

The indicator of the currently selected ENCODER MODE button lights up.

The following table shows the exact Encoder functions for each Layer and Encoder mode.

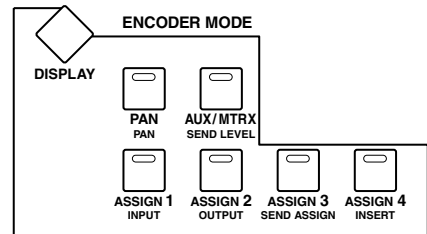

Layer	Encoder Mode	Encoder			
		1–8	9–16	17–20	21–24
1–24	Pan	CH 1–24: pan			
	Aux/Mtrx	CH 1–24: Aux Send level			
	Assign 1–4	CH 1–24: assigned parameter <sup>1</sup>			
25–48	Pan	CH 25–48: pan			
	Aux/Mtrx	CH 25–48: Aux Send level			
	Assign 1–4	CH 25–48: assigned parameter <sup>1</sup>			
49–72	Pan	CH 49–72: pan			
	Aux/Mtrx	CH 49–72: Aux Send level			
	Assign 1–4	CH 49–72: assigned parameter <sup>1</sup>			
73–96	Pan	CH 73–96: pan			
	Aux/Mtrx	CH 73–96: Aux Send level			
	Assign 1–4	CH 73–96: assigned parameter <sup>1</sup>			
Master	Pan	No operation	No operation	Matrix 1–4: Balance	
	Aux/Mtrx	Bus Out 1–8: Matrix Send level	Aux Send 1–12: Matrix Send level	No operation	
	Assign 1–4	Bus Out 1–8: assigned parameter	Aux Send 1–12: assigned parameter	Matrix Send 1–4: assigned parameter	
Remote 1–4	Pan	Operation depends on the selected target. See “About Remote Layers” on page 253 for more information.			
	Aux/Mtrx				
	Assign 1–4				

1. When Alt Layer is assigned, the Encoders enable you to control a parameter that is assigned to the corresponding channel fader in the partner layer. (A partner layer would be the layer of channels 25-48 if the layer of channels 1-24 is currently selected, or the layer of channels 73-96 if the layer of channels 49-72 is currently selected.)

The values of the parameters being controlled by the Encoders are displayed graphically by the channel strip displays. See “Channel Strip Displays” on page 55 for more information.

## Assigning Parameters to the ENCODER MODE Assign Buttons

Up to four parameters can be assigned to the four ENCODER MODE ASSIGN buttons.

Initially, the following parameters are assigned to the ASSIGN buttons:

[ASSIGN 1]: Input Patch

[ASSIGN 2]: Direct Out

[ASSIGN 3]: Surr. LFE Level

[ASSIGN 4]: Surr. Pan Wheel

- 1 Use the ENCODER MODE [DISPLAY] button to select the Encoder Mode Assign page.

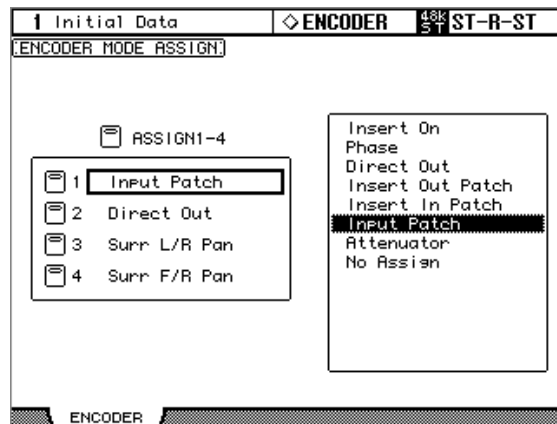

The names of the parameters currently assigned to each ASSIGN button are displayed in the left-hand box. The parameter currently assigned to the selected ASSIGN button appears highlighted in the right-hand box.

- 2 Press an ASSIGN button, or use the Up/Down cursor buttons, to select an ASSIGN button.
- 3 Use the Parameter wheel, or the INC/DEC buttons to select a parameter.

A parameter is selected when it appears inside the dotted box.

See the “Assignable Encoder Mode Parameter List” on page 63 for a complete list of assignable parameters.

- 4 Press the [ENTER] button to assign your choice.

Once assigned, the selected parameter appears highlighted in the right-hand box.

When channels that do not feature the currently assigned parameter are selected, the Encoders are inactive. For example, if the assigned Encoder parameter is “Phase,” and the Master Layer is selected, the Encoders are inactive, because the Bus Outs, Aux Sends, and Matrix Sends do not feature Phase parameters.

### Assignable Encoder Mode Parameter List

#	Parameter	Encoder Operation	Push Switch Operation
1	No Assign	—	—
2	Attenuator	Attenuator	—
3	Input Patch	Input Channel patch	Confirm or execute patch selection.
4	Insert In Patch	Insert In patch	Confirm or execute patch selection.
5	Insert Out Patch	Insert Out patch	Confirm or execute patch selection.
6	Direct Out	Direct Out patch	Confirm or execute patch selection.
7	Phase	Phase: normal/reverse	—
8	Insert On	Insert on/off	—
9	Aux pre/post	Aux pre/post	—
10	Delay On	Delay on/off	—
11	Delay Time	Delay Time	—
12	Delay FB.Gain	Delay FB.Gain	—
13	Delay Mix	Delay Mix	—
14	EQ On	EQ on/off	—
15	EQ Type	EQ Type	—
16	EQ Low Q	EQ Low Q	—
17	EQ Low F	EQ Low Frequency	—
18	EQ Low G	EQ Low Gain	—
19	EQ Low-Mid Q	EQ Low-Mid Q	—
20	EQ Low-Mid F	EQ Low-Mid Frequency	—
21	EQ Low-Mid G	EQ Low-Mid Gain	—
22	EQ High-Mid Q	EQ High-Mid Q	—
23	EQ High-Mid F	EQ High-Mid Frequency	—
24	EQ High-Mid G	EQ High-Mid Gain	—
25	EQ High Q	EQ High Q	—
26	EQ High F	EQ High Frequency	—
27	EQ High G	EQ High Gain	—
28	Gate On	Gate on/off	—
29	Gate Threshold	Gate Threshold	—
30	Gate Range	Gate Range	—
31	Gate Attack	Gate Attack	—
32	Gate Decay	Gate Decay	—
33	Gate Hold	Gate Hold	—
34	Comp On	Comp on/off	—
35	Comp Threshold	Comp Threshold	—
36	Comp Ratio	Comp Ratio	—
37	Comp Attack	Comp Attack	—
38	Comp Release	Comp Release	—
39	Comp Out Gain	Comp Out Gain	—
40	Comp Knee/Width	Comp Knee/Width	—
41	Surr L/R Pan	Surround L/R Pan	—
42	Surr F/R Pan	Surround F/R Pan	—
43	Surr Front DIV	Surround Front DIV	—
44	Surr Rear DIV	Surround Rear DIV	—
45	Surr. LFE Level	Surround LFE level	—
46	Surr. Pan Wheel	Surround Pan Wheel	—
47	Scene Fade Time	Scene Fade Time	—
48	Alt Layer	Alt Layer	Indicate values on the channel strip displays.
49	HA Gain	HA Gain	—
50	Ins HA Gain	HA Insert Gain	—

## 4 Analog I/O & the AD Input Section

### AD Input Section

The DM2000 features 24 AD Inputs for connecting microphone and line-level sources. AD Inputs can be patched to Input Channels or Input Channel Insert Ins (see page 77). They can also be patched to Output Channel Insert Ins (see page 80).

#### AD Input Connectors

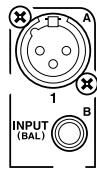

AD Inputs feature balanced XLR-3-31-type connectors and balanced 1/4-inch phone jacks, both with a nominal input range of  $-60$  dB to  $+10$  dB. The phone jacks, which can also be used with unbalanced phone plugs, have priority over the XLR-type connectors, so when a phone plug is inserted, the XLR-type connector is disconnected.

#### Phantom Power



AD Inputs feature switchable  $+48$  V phantom powering for use with condenser-type microphones and direct boxes. Phantom power is supplied to the balanced XLR-3-31-type connector, and can be switched individually for each AD Input.

##### Caution:

- If you don't need phantom power, be sure to turn the switch off.
- Before you turn phantom power on, make sure that no devices other than phantom-powered devices, such as a condenser microphone, are connected. Otherwise, you risk damaging the devices.
- Do not connect or disconnect a device while phantom power is applied. Doing so can damage the connected device and/or the unit itself.
- To protect your speaker system, leave the power amps (powered speakers) turned off when switching the phantom power on/off. We also recommend that you set all output level faders to the minimum position. Otherwise, high-volume output may damage your hearing or equipment.

#### Pad



AD Inputs feature pad switches, which attenuate input signals by 26 dB, allowing the Head Amps to work with high-level signals. Pad is typically used to attenuate “hot” signals from bass or snare drum microphones, or “hot” line-level signals.

#### Gain



AD Inputs feature detented rotary gain controls with an input sensitivity of  $-16$  dB to  $-60$  dB, or  $+10$  dB to  $-34$  dB when the Pad is on. The GAIN controls adjust the gain of the Head Amps, allowing you to optimize input signal levels for the best signal-to-noise performance. Ideally, the GAIN control should be set so that the signal level is relatively high, and it's okay for the PEAK indicator to light up occasionally. If the PEAK indicator lights up often, however, you should back off the GAIN control a little, otherwise, signal clipping may occur. If the GAIN is set too low, the signal-to-noise performance will suffer.



### PEAK & SIGNAL Indicators



These indicators are used in conjunction with the GAIN controls and PAD switches to optimize signal levels. The SIGNAL indicator lights up when the input signal level is 20 dB below the rated level. The PEAK indicator lights up when the input signal level is 3 dB below clipping.

### AD Inserts

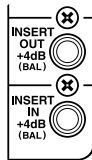

AD Inputs feature switchable analog inserts with individual balanced 1/4-inch TRS phone jacks for the send and return signals. They are wired: sleeve–ground, ring–cold, tip–hot. The rated level for both connectors is +4 dB.



AD Input inserts can be turned on and off individually by using the INSERT ON/OFF switches, so you don't have to disconnect your external equipment in order to remove an insert.

### Stereo Out

See page 104 for information on the Stereo Out outputs.

### Control Room Monitor Outs

See page 158 for information on the Control Room Monitor outputs.

### Studio Monitor Outs

See page 159 for information on the Studio Monitor outputs.

### Omni Outs

The DM2000 features assignable Omni Outs on balanced 1/4-inch TRS phone jacks. Omni Outs can be patched to Bus Outs, Aux Sends, Matrix Sends, the Stereo Out, Input or Output Channel Insert Outs, or Surround Monitor Channels (see page 80). In addition, Input Channel Direct Outs can be patched to the Omni Outs (see page 81).

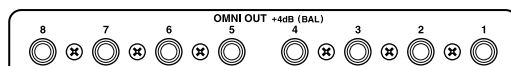

The maximum output level of each OMNI OUT can be set internally to either +4 dB (–10 dB operating level) or +18 dB (+4 dB operating level). Contact your dealer for further details.

### 2TR Analog INs

The DM2000 features two sets of 2-track analog inputs: 2TR IN ANALOG 1 +4 dB (BAL) uses balanced 1/4-inch TRS phone jacks. 2TR IN ANALOG 2 –10 dBV (UNBAL) uses unbalanced phono jacks. These inputs can be monitored via the Control Room monitors by pressing the CONTROL ROOM [2TR A1] and [2TR A2] buttons. They can be patched to Input Channels (see page 77), Input Channel Insert Ins (see page 78), or Output Channel Insert Ins (see page 80).

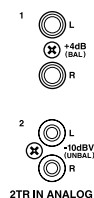

## 5 Digital I/O & Cascading

### Wordclocks

Unlike analog audio equipment, digital audio equipment must be synchronized when digital audio signals are transferred from one device to another, otherwise, signals may not be received correctly and audible noise, glitches, or clicks may occur. Synchronization is achieved using what's called a *wordclock*, which is a clock signal for synchronizing all the digital audio signals in a system. Note that wordclocks are not the same as SMPTE/EBU or MTC timecode, which is typically used to synchronize tape machines, MIDI sequencers, and so on. Wordclock synchronization refers to the synchronization of the digital audio processing circuits inside each digital audio device.

In a typical digital audio system, one device operates as the wordclock master, and the other devices operate as wordclock slaves, synchronizing to the wordclock master. Wordclock signals can be distributed via dedicated cables, typically BNC cables, or derived from digital audio connections, including AES/EBU, ADAT, and Tascam formats.

If you're connecting to the DM2000 using only analog inputs and outputs, no special wordclock settings are required, and the DM2000 can be set to use its own internally generated wordclock. If you're connecting other equipment digitally, however, you must decide which device to use as the wordclock master and which devices to use as slaves.

The DM2000 can be used as the wordclock master running at either 44.1 kHz, 48 kHz, 88.2 kHz, or 96 kHz, or slaved to an external wordclock source. External wordclock signals can be received via the Slot Inputs, 2TR Digital Inputs, the CASCADE IN port, or the dedicated BNC WORD CLOCK IN connector.

In a system where all devices share a common wordclock, it's important that all devices be turned on even if they're not being used. Turn on the wordclock master first, and then the slaves. When shutting down the system, turn off the slaves first, and then the master. Before use, make sure that the wordclock slaves are correctly locked to the wordclock master. Most devices have front panel indicators to indicate this. Refer to the relevant owner's manuals for more information.

### Wordclock Connections

The DM2000 features one BNC wordclock input and two BNC wordclock outputs. External wordclock signals can be connected to the WORD CLOCK IN connector, and terminated by using the 75Ω ON/OFF switch (see page 68). WORD CLOCK OUT 1 outputs a wordclock signal at the same clock rate as the DM2000. WORD CLOCK OUT 2 outputs a wordclock signal at half the clock rate of the DM2000 when using 88.2 kHz or 96 kHz, so if the DM2000 is running at 96 kHz, a wordclock signal at 48 kHz is output here.

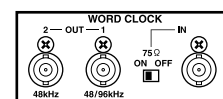

## Selecting the Wordclock Source

The wordclock source can be selected as follows.

*Note: When you change the wordclock settings on any device in your digital audio system, some devices may output noise, so turn down your power amps beforehand, otherwise your speakers may be damaged.*

- 1 Use the DISPLAY ACCESS [DIO] button to locate the Word Clock Select page.

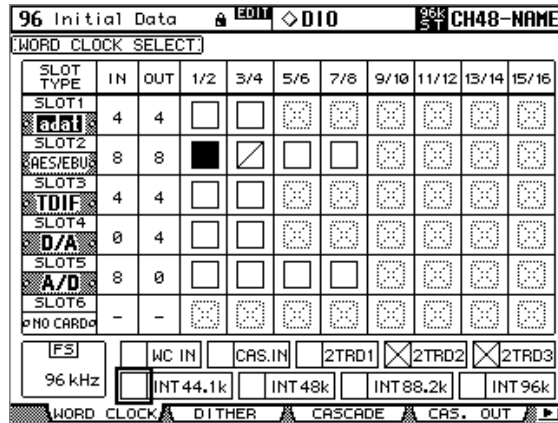

- 2 Use the cursor buttons to select the sources, and press [ENTER] to set.

The SLOT TYPE column displays the names of any installed I/O Cards. The IN and OUT columns indicate the number of inputs and outputs available for each installed I/O Card. The FS box in the lower-left corner displays the current wordclock status: 44.1kHz, 48kHz, 88.2kHz, 96kHz, or Unlock.

The following are possible wordclock sources:

**SLOT1–6 (1/2–15/16):** These buttons select the Slot Inputs as the wordclock source. Inputs are selected in pairs, the number of pairs depending on the type of I/O Card installed.

**WC IN:** This button selects the WORDCLOCK IN connector as the wordclock source.

**CAS. IN:** This button selects the CASCADE IN port as the wordclock source.

**2TRD1, 2TRD2, 2TRD3:** These buttons select the 2TR Digital Inputs as the wordclock source.

**INT44.1k, INT48k, INT88.2k, INT96k:** These buttons select the internal wordclock generator as the wordclock source.

The source select buttons have the following indications:

- A usable wordclock signal is present at this input.
- No wordclock signal is present at this input.
- A wordclock signal is present, but it's out of sync with the current DM2000 clock.
- This is the currently selected wordclock source.
- This input was selected as the wordclock source, but no usable signal was received.
- This cannot be selected as the wordclock source because a wordclock signal cannot be sourced from this input on this type of I/O Card, or no I/O Card is installed.

If an external wordclock source fails for some reason, the DM2000 automatically switches to its internal wordclock generator at the closest frequency.

### Terminating External Wordclocks

Wordclock signals distributed via BNC cables must be terminated correctly, otherwise, jitter and synchronization errors may result. Ideally, you should make a separate wordclock connection to each device and terminate it. The following examples show two ways in which wordclock signals can be distributed and how termination should be applied in each case. Normally the WORD CLOCK 75Ω ON/OFF switch should be set to ON. The OFF setting provides support for wordclock source devices with special specifications.

#### Star Distribution

In this example a dedicated wordclock distribution box is used to supply wordclock signals to each device individually. Termination is applied at each device.

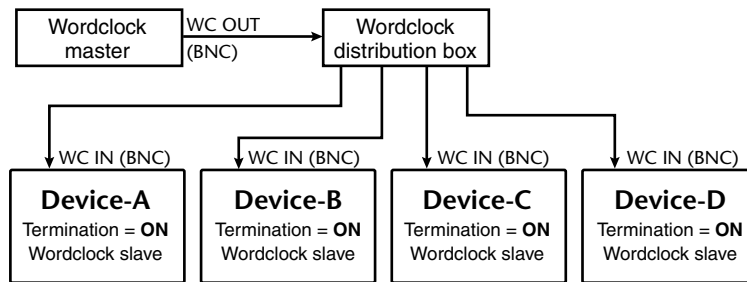

#### Daisy Chain Distribution

In this example the wordclock signal is distributed in a “daisy-chain” fashion, with each device feeding the wordclock signal on to the next. This method of distribution is not recommended for larger systems.

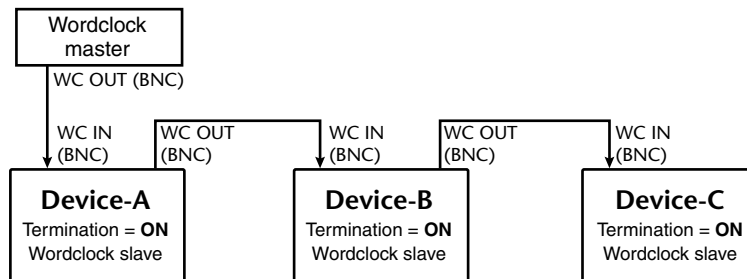

### 2TR Digital Outs

The DM2000 features three sets of 2-track digital outputs: 2TR OUT DIGITAL AES/EBU 1 and AES/EBU 2 use XLR-3-32-type connectors and output AES/EBU format digital audio. 2TR OUT DIGITAL COAXIAL 3 uses a phono connector and outputs consumer format

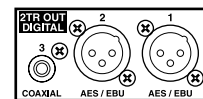

(IEC-60958) digital audio. These outputs can be patched to the Bus Outs, Aux Sends, Matrix Sends, the Stereo Out, Input or Output Channel Insert Outs, or the Control Room signal (see page 81). They can also be patched to Direct Outs (see page 81). These outputs can output digital audio signals at sampling rates other than the current DM2000 rate by using the internal sampling rate converters (see page 69). Digital output signals can be dithered for transfer to lower-resolution systems (see page 73).

## 2TR Digital Ins

The DM2000 features three sets of 2-track digital inputs: 2TR IN DIGITAL AES/EBU 1 and AES/EBU 2 use XLR-3-31-type connectors and accept AES/EBU format digital audio. 2TR IN DIGITAL COAXIAL 3 uses a phono connector and accepts consumer format

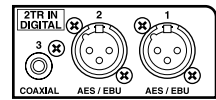

(IEC-60958) digital audio. These inputs can be monitored via the Control Room monitors by using the CONTROL ROOM [2TR D1], [2TR D2], and [2TR D3] buttons. They can be patched to Input Channels (see page 77), Input Channel Insert Ins (see page 78), or Output Channel Insert Ins (see page 80). Digital audio signals received at sampling rates other than the current DM2000 rate can be converted by the internal sampling rate converters (see page 69). You can monitor the Channel Status of digital signals present at these inputs on the Channel Status Monitor page (see page 73).

## 2TR In/Out Sampling Rate Conversion

The DM2000's 2TR Digital Inputs and Outputs feature sampling rate converters so you can easily connect your legacy 44.1/48 kHz digital audio equipment.

- 1 Use the **DISPLAY ACCESS [DIO]** button to locate the **Sampling Rate Converter** page.

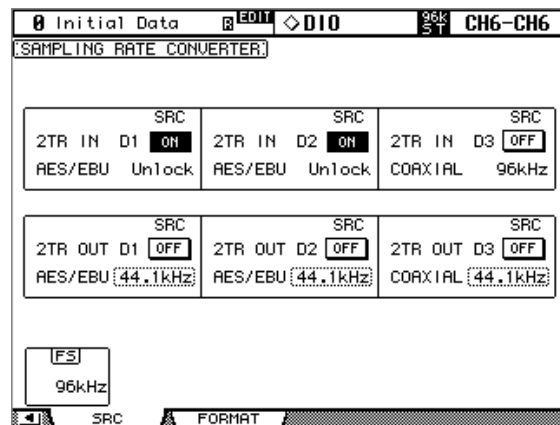

- 2 Use the cursor buttons to select the parameters, and use the **Parameter wheel**, **INC/DEC** buttons, or **[ENTER]** button to set them.

The FS box in the lower-left corner displays the current wordclock status: 44.1kHz, 48kHz, 88.2kHz, 96kHz, or Unlock.

**2TR IN D1–3:** These buttons are used to turn on and off the sampling rate converter for each 2TR Digital Input. When on, the sampling rate of the received digital audio is converted to the DM2000's current sampling rate. The original sampling rate is displayed.

**2TR OUT D1–3:** These buttons are used to turn on and off the sampling rate converters for each 2TR Digital Output. When on, the sampling rate of the transmitted digital audio is converted to the specified rate, which can be set to either 44.1 kHz or 48 kHz.

## Slot I/O

The DM2000 features six Slots for installing optional mini-YGDAI (Yamaha General Digital Audio Interface) I/O Cards, which offer various analog I/O options and digital I/O interfaces in all the popular digital audio interconnect formats, including AES/EBU, ADAT, and Tascam.

Slot Inputs can be assigned to Input Channels or Input Channel Insert Ins (see page 77), or to Output Channel Insert Ins (see page 80). Slot Outputs can be assigned to Bus Outs, Aux Sends, Matrix Sends, the Stereo Out, Insert Outs, or the Surround Monitor Channels (see page 79), or Direct Outs (see page 81).

Slot outputs can be dithered for digital audio transfer to lower-resolution systems (see page 73).

### Available Cards

The following mini-YGDAI I/O Cards are currently available. See the Yamaha Professional Audio Web site at the following URL for up-to-date news on I/O Cards: <<http://www.yamahaproaudio.com/>>.

Card	Format	In	Out	Resolution/Sampling Rate	Connectors
MY8-AD	Analog in	8	—	20-bit, 44.1/48 kHz	Phone jack (balanced) x8
MY8-AD24 <sup>1</sup>				24-bit, 44.1/48 kHz	
MY4-AD		4		24-bit, 44.1/48/88.2/96 kHz	D-sub 25-pin
MY8-AD96		8			
MY4-DA	Analog out	—	4	20-bit, 44.1/48 kHz	XLR-3-32 type (balanced) x4
MY8-DA96		—	8	24-bit, 44.1/48/88.2/96 kHz	D-sub 25-pin
MY8-ADDA96	Analog in/out	8	8		
MY8-AE <sup>2</sup>	AES/EBU I/O	8	8	24-bit, 44.1/48 kHz	D-sub 25-pin
MY16-AE <sup>2</sup>		16	16		
MY8-AEB		8	8		24-bit, 44.1/48/88.2/96 kHz
MY8-AE96		8	8	D-sub 25-pin	
MY8-AE96S <sup>3</sup>					
MY8-AT <sup>2</sup>	ADAT I/O	8	8	24-bit, 44.1/48 kHz	Optical x2
MY16-AT <sup>2</sup>		16	16		Optical x4
MY8-TD <sup>2</sup>	Tascam	8	8		D-sub 25-pin BNC wordclock output
MY16-TD <sup>2</sup>		16	16		
MY8-mLAN <sup>2</sup>	IEEE1394	8	8		6-pin 1394 connector x2
MY16-mLAN <sup>2</sup>		16	16		
MY16-C <sup>2</sup>	CobraNet	16	16	24-bit, 44.1/48 kHz	RJ-45 x2
WAVES Y56K	ADAT	8	8	24-bit, 44.1/48 kHz	Optical x2
WAVES Y96K				24-bit, 44.1/48/88.2/96 kHz	

1. This card is a substitution for a 20-bit MY8-AD card.

2. These cards support 24-bit/96 kHz in Double Channel mode. (Separate 96 kHz wordclock required.)

3. This card is identical to the MY8-AE96, except that it features a sampling rate converter.

## Installing I/O Cards



For technical reasons, certain card combinations are not supported. Before installing any cards, check the Yamaha web site (see page 6) to see whether your card is compatible.

<http://www.yamahaproaudio.com/>

Also check the total number of cards that can be installed in the unit. Installing cards that are not endorsed by Yamaha may cause electrical shock, fire, or damage to the unit.

This section explains how to install I/O Cards.

- 1 Turn off the DM2000.
- 2 Undo the two fixing screws and remove the slot cover, as shown below.

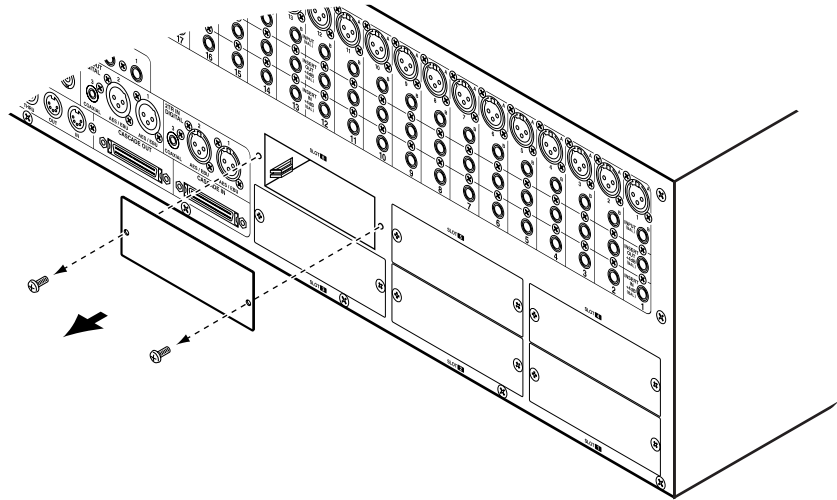

Keep the cover and fixing screws in a safe place for future use.

- 3 Insert the card between the guide rails and slide it all the way into the slot, as shown below. You may have to push firmly to plug the card into the internal connector.

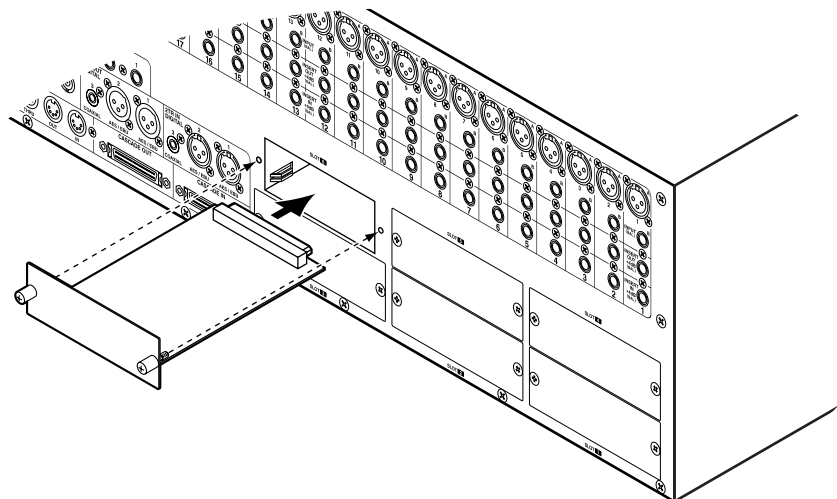

- 4 Secure the card using the attached thumbscrews. Do not leave them loose, as the card will not be grounded correctly, which may cause the DM2000 to malfunction.

You can check which I/O Cards are installed on the Word Clock Select page (see page 67).

## Setting the Transfer Format for Higher Sampling Rates

The data transfer format for the higher sampling rates can be set as follows.

- 1 Use the **DISPLAY ACCESS [DIO]** button to locate the **Higher Sample Rate Data Transfer Format** page.

SLOT TYPE	IN	OUT	SRC			
			1/2	3/4	5/6	7/8
SLOT1 ADAT	DOUBLE CHANNEL	DOUBLE CHANNEL	-	-	-	-
SLOT2 AES/EBU	DOUBLE SPEED	DOUBLE CHANNEL	OFF 96 kHz	ON 44.1 kHz	ON 48 kHz	ON 88.2 kHz
SLOT3 TDIF	DOUBLE CHANNEL	DOUBLE CHANNEL	-	-	-	-
SLOT4 D/A	-	-	-	-	-	-
SLOT5 A/D	-	-	-	-	-	-
SLOT6 NO CARD	-	-	-	-	-	-

- 2 Use the cursor buttons to select the parameters, and use the **Parameter wheel**, **INC/DEC** buttons, or **[ENTER]** button to set them.

The **SLOT TYPE** column displays the names of any installed I/O Cards.

**IN/OUT:** These parameters are used to set the input and output data transfer format of I/O Cards when running at the higher sampling rates (i.e., 88.2 kHz or 96 kHz) to either Double Channel, Double Speed or Single. In Double Speed mode, digital audio data is received and transmitted at the current higher sampling rate (i.e., 88.2 kHz or 96 kHz). In Double Channel mode, digital audio data is received and transmitted at a sampling rate that is exactly half the current higher sampling rate and data is handled by two channels, thereby reducing the total number of inputs or outputs for an eight channel I/O Card to four. In Double Channel mode, the even-numbered channels are disabled. Double Channel mode allows you to record 96 kHz audio to legacy 44.1/48 kHz digital multitrack recorders. In Single mode, digital audio data is received and transmitted at a sampling rate that is exactly half the current higher sampling rate. This is useful for digital MTR recording and playback situations. The IN and OUT parameters are only available when a higher sampling rate (i.e., 88.2 kHz or 96 kHz) is selected. When the sampling rate is 44.1 kHz or 48 kHz, all parameters on this page are unavailable. As are individual parameters for Slots with analog I/O Cards installed, or no I/O Card installed. When a digital I/O card that does not support 88.2/96 kHz is installed, such as the MY8-AE, MY8-AT, or MY8-TD, its IN and OUT formats cannot be set to Double Speed mode.

**SRC:** These parameters are used to turn on and off the sampling rate converter for each pair of Slot Inputs. When on, the sampling rate of the received digital audio is converted to the DM2000's current sampling rate. The original sampling rate is displayed. These parameters are available only when an I/O Card with onboard sampling rate converters is installed, such as the MY8-AE96S.



## Dithering Digital Outputs

For digital audio transfer to lower-resolution systems, the 2TR Digital Outputs and Slot Outputs can be dithered to 16-bit, 20-bit, or 24-bit.

- 1 Use the **DISPLAY ACCESS [DIO]** button to locate the Dither page.

Initial Data		DIO		CH6-CH6	
[DITHER]					
2TR OUT D1	24bit	2TR OUT D2	24bit	2TR OUT D3	24bit
AES/EBU		AES/EBU		COAXIAL	
	1/2	3/4	5/6	7/8	9/10
SLOT1	20bit	20bit	OFF	OFF	OFF
AES/EBU					
SLOT2	OFF	OFF	OFF	OFF	OFF
NO CARD					
SLOT3	OFF	OFF	OFF	OFF	OFF
NO CARD					
SLOT4	OFF	OFF	OFF	OFF	OFF
NO CARD					
SLOT5	24bit	24bit	OFF	OFF	OFF
AES/EBU					
SLOT6	OFF	OFF	24bit	24bit	24bit
AES/EBU					
WORD CLOCK DITHER CASCADE CAS OUT					

- 2 Use the cursor buttons to select the Dither parameters, and use the Parameter wheel or INC/DEC buttons to set them.

The SLOT column displays the names of any installed I/O Cards.

You can copy the currently selected setting to all Dither parameters by double-clicking the [ENTER] button.

## Monitoring Digital Input Channel Status

You can monitor the Channel Status of digital audio signals connected to the 2TR Digital Inputs and Slot Inputs as follows.

- 1 Use the **DISPLAY ACCESS [UTILITY]** button to locate the Channel Status Monitor page.

Initial Data		UTILITY		CH1-CH1	
[CHANNEL STATUS MONITOR]					
SLOT4	SLOTS	SLOTS	SLOTS	SLOTS	SLOTS
SLOT1	SLOT2	SLOT3	2TR IN	AES/EBU	
	SLOTS	SLOTS	SLOTS	SLOTS	
	1/2	3/4	5/6	7/8	
FS	48kHz	48kHz	48kHz	48kHz	
EMPHASIS	Off	Off	Off	Off	
CATEGORY	AES/EBU	AES/EBU	AES/EBU	AES/EBU	
COPY	---	---	---	---	
01-08					
OSCILLATOR CH STATUS BATTERY LOCK					

- 2 Use the cursor buttons to select the SLOT 1–6 and 2TR IN buttons, then press [ENTER].

Displayed Channel Status information includes sampling rate (FS), emphasis, category, and copy protection.

However, if a mini-YGDAI I/O card other than AES/EBU format is installed, Channel Status information will be grayed out.

- 3 If you select the SLOT button for a slot that has an MY16-AE card installed, use the 01–08 and 09–16 buttons located in the lower-right corner of the screen to select a channel group you wish to display.

01–08

09–16

## Cascading Consoles

Total four DM2000s or 02R96s can be cascaded, offering a maximum of 384 Input Channels. Several functions are linked between all cascaded consoles, including Solo, Scene Recall and Store, so that all consoles work just like one big console. A single Yamaha 02R Digital Recording Console can be included in the cascade system.

The CASCADE IN and CASCADE OUT ports are used to transmit and receive Cascade and control signals.

Only use the optional dedicated Cascade cables for connecting.



## Linked Functions

The following DM2000 functions are linked via the cascade ports:

- AUX SELECT (Aux 9–12 are not linked with the 02R96.)
- MATRIX SELECT (Not linked with the 02R96.)
- Display page selection (Not linked with the 02R96.)
- Solo function
- FADER MODE
- ENCODER MODE
- Metering position setting
- Peak Hold On/Off
- Meter Fast Fall on/off
- Scene Store, Recall, and Title Edit

When a Scene is recalled on the master console, that scene is recalled on all cascaded consoles.

- The following Automix functions: Make New Automix, Store, Recall, Title Edit, Transport (AutoREC, REC, PLAY, STOP, ABORT).
- The following Automix parameters: Automix Enable/Disable, Internal Start Time, Offset Time, Frame Rate, Overwrite (FADER, ON, PAN, SURR, AUX, AUX ON, EQ), Motor ON/OFF, Edit Out Mode OFF/RETURN/TAKEOVER, Return Time, Update To End On/Off, ABSOLUTE/RELATIVE Fader Edit Mode, Touch Sense Edit Off/Touch/Latch.

Function and parameter linking can be turned on or off by using the Cascade COMM Link preference (see page 276). The Solo function is always linked regardless of this preference.

*Note: When the Cascade COMM Link preference is on, do not make any MIDI connections between cascaded DM2000s/02R96s. If two DM2000s/02R96s are cascaded and connected via MIDI, and the Cascade COMM Link preference is on, when a store operation is performed on the master console, a loop will be created, causing both consoles to execute endless store operations.*

## Cascade Hookup Examples

### Cascading Two DM2000s

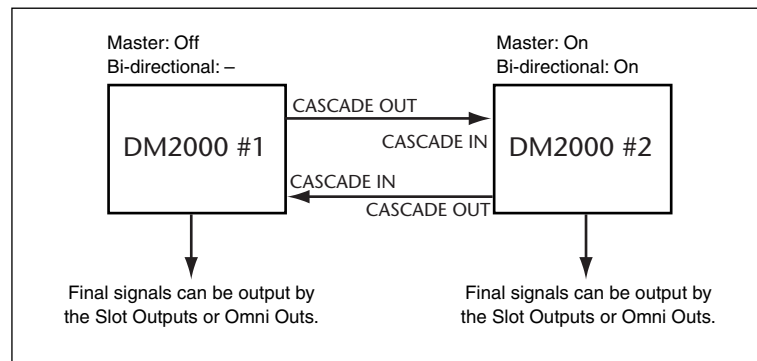

### Cascading Three or More DM2000s

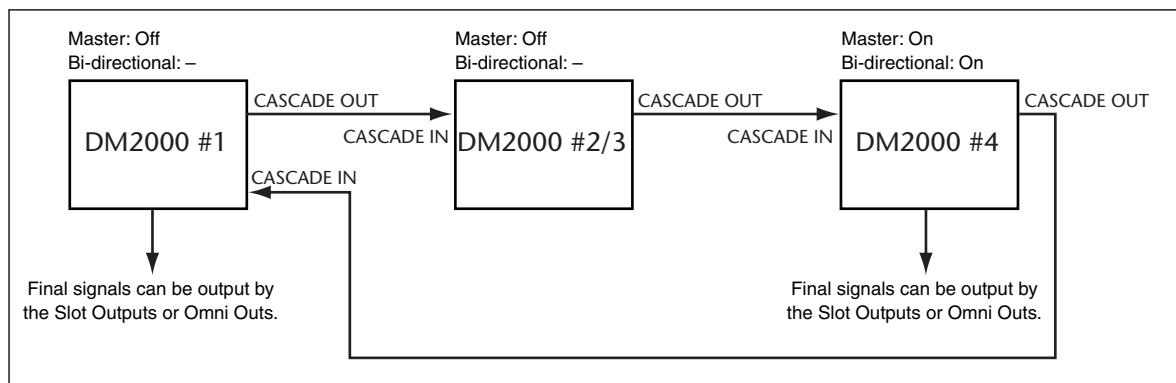

### Cascading an 02R Digital Recording Console

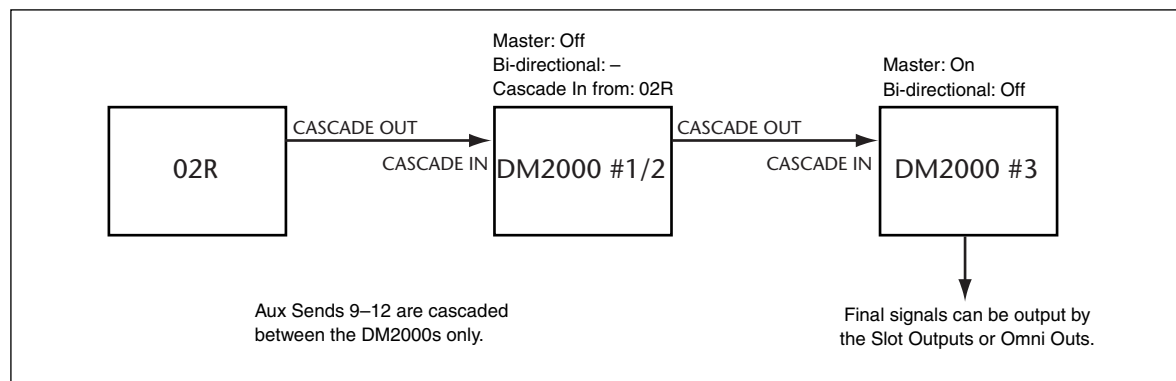

### Attenuating Cascade Inputs

Cascade Inputs can be attenuated, and the Cascade mode and Cascade source can be specified on the Cascade In page.

- 1 Use the DISPLAY ACCESS [DIO] button to locate the Cascade In page.

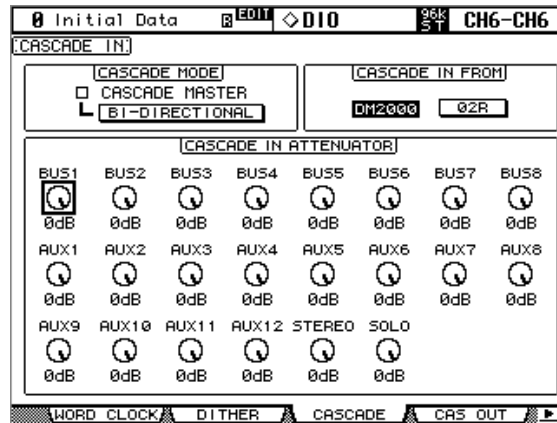

- 2 Use the cursor buttons to select the parameters, and use the Parameter wheel, INC/DEC buttons, or [ENTER] button to set them.

**CASCADE MODE:** When you want to output the same signals from two DM2000s, turn on the BI-DIRECTIONAL button. In this case, the Cascade connections are looped. Turn on the CASCADE MASTER option on one of the DM2000s to make it the master console. When the BI-DIRECTIONAL button is off, the last DM2000 in the cascade is automatically configured as the master console and it output the final signals.

**CASCADE IN FROM:** This is used to specify the type of device connected to the CASCADE IN port, either DM2000 or 02R. When a DM2000 or 02R96 is connected to the CASCADE IN port, DM2000 is specified automatically.

**CASCADE IN ATTENUATOR:** These controls are used to attenuate Cascade Input signals. You can copy the currently selected setting to all Attenuator parameters by double-clicking the [ENTER] button.

### Turning On & Off Cascade Outputs

Individual Cascade Outputs can be turned on or off as follows.

- 1 Use the DISPLAY ACCESS [DIO] button to locate the Cascade Out page.

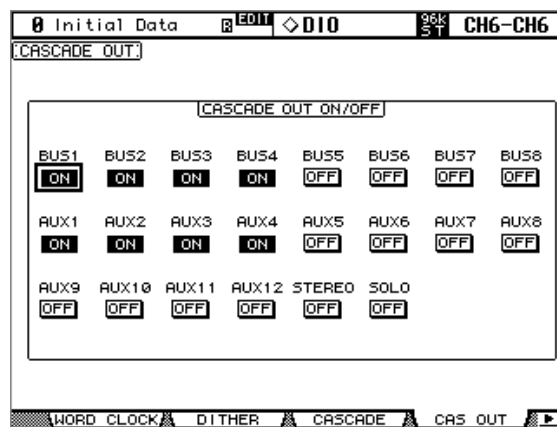

- 2 Use the cursor buttons to select the ON/OFF buttons, and use the [ENTER] button to set them.

## 6 Input & Output Patching

### Input Patching

Input and Output signals for the Input Channels, Input Channel Insert Ins, and internal effects processors are selected on the Input Patch pages, which you select using the DISPLAY ACCESS [INPUT PATCH] button. Use the cursor buttons to select the patch parameters, use the Parameter wheel or INC/DEC buttons to select a source, and press [ENTER] to set. Patch parameters display Short Port names. The Long Port name of the currently selected patch parameter is displayed in the upper-right corner of each page.

Patching can also be done by using the Patch Select Window (see page 83). Input Channel Inputs, Insert Ins, and Insert Outs can also be patched by using the Encoders (see page 83). See page 286 for a complete list of input patch sources. See page 289 for a list of initial input patches.

Input Patch settings can be stored in the Input Patch library, which contains 1 preset memory and 32 user memories. See “Input Patch Library” on page 167 for more information.

### Patching Input Channels

AD Inputs, Slot Inputs, internal effects Processor outputs, Digital or Analog 2TR Inputs, Bus Outs, or Aux Sends can be patched to the Input Channel Inputs.

The Input Channel Patch parameters for the 96 Input Channels are divided between two pages. The Input Channel 1–48 Patch page is shown below. The layout of the other page is the same. When Vertical Input Channel pairing mode is selected, patch parameters for vertical partners are displayed, for example, CH1, CH25, CH2, CH26, and so on.

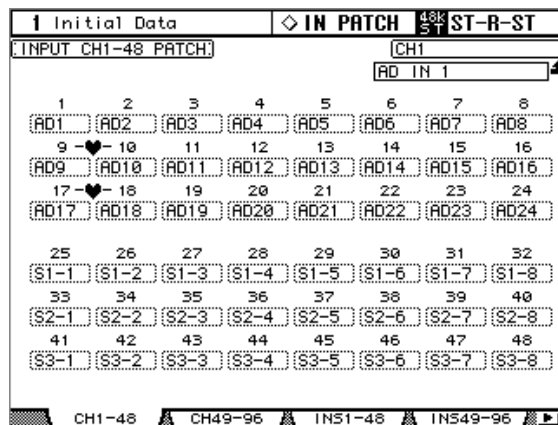

In addition to using the cursor buttons, Patch parameters can also be selected by using the [SEL] buttons and the Input Layers.

### Patching Input Channel Insert Ins

AD Inputs, Slot Inputs, internal effects processor outputs, Digital or Analog 2TR Inputs can be patched to the Input Channel Insert Ins.

The Input Channel Insert In Patch parameters for the 96 Input Channels are divided between two pages. The Input Channel 1–48 Insert In Patch page is shown below. The layout of the other page is the same. When Vertical Input Channel pairing mode is selected, patch parameters for vertical partners are displayed, for example, CH1, CH25, CH2, CH26, and so on.

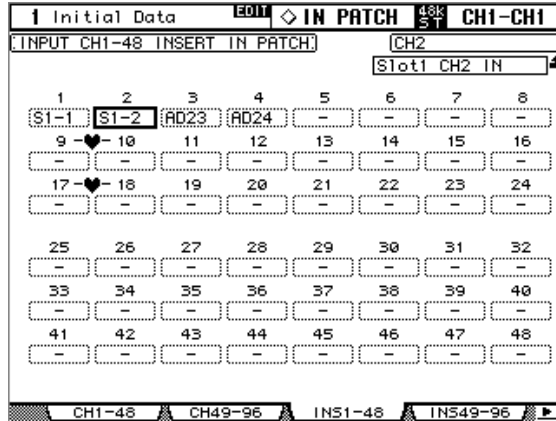

In addition to using the cursor buttons, Patch parameters can also be selected by using the [SEL] buttons.

### Patching Effects Inputs and Outputs

Aux Sends, internal effects processor outputs (OUT1 and OUT2 only), or Output Channel Insert Outs can be patched to the internal effects processor inputs.

Input Channels, or Insert Ins can be patched to the internal effects processor outputs. Internal effects processor inputs can be also patched to the internal effects processor outputs (OUT1 and OUT2 only).

The internal effects processor Input Patch parameters are divided between two pages: One for Effects Processors #1 and #2, and one for Effects Processors 3–8. The effects type for each Effects Processor is displayed in the boxes.

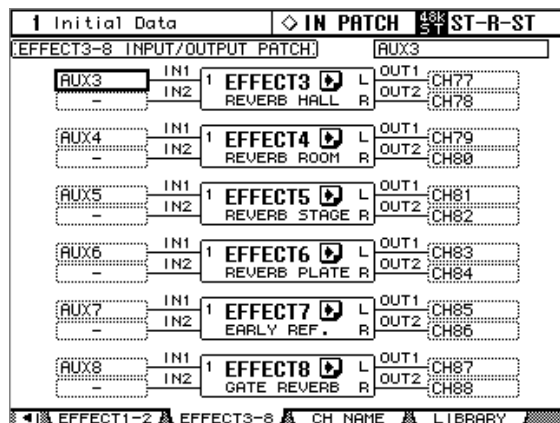
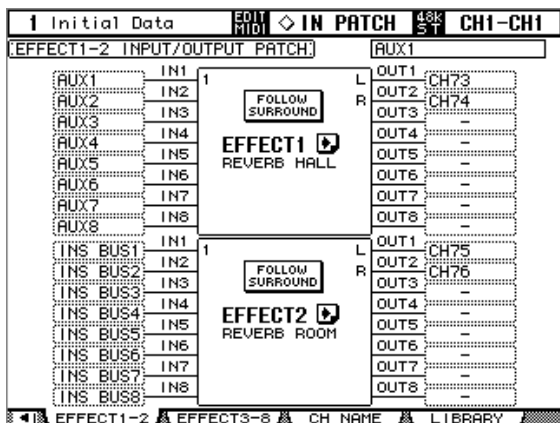

**FOLLOW SURROUND:** When surround effects are recalled to Effects processor 1 or 2, this button sorts the effect inputs and outputs displayed in the list in the order specified on the Surround Bus Setup page (see page 99). If the recalled surround effects are compatible with 5.1 Channel systems, the surround bus setting for 5.1 surround mode will be used.

: Press this button repeatedly until an Effect Edit (1–8) page for the effects processor you wish to edit appears.

## Output Patching

Signal sources for the Slot Outputs, Omni Outs, Output Channel Inserts Ins, Direct Outs, 2TR Digital Outputs, and GEQs are selected on the Output Patch pages, which are selected by using the DISPLAY ACCESS [OUTPUT PATCH] button. Use the cursor buttons to select the patch parameters, use the Parameter wheel or INC/DEC buttons to select a source, and press [ENTER] to set.

Depending on the patch page, patch parameters display either Short Channel or Short Port names. The Long Channel or Port name of the currently selected patch parameter is displayed in the upper-right corner of each page.

Signal sources can also be selected by using the Patch Select Window (see page 83). Insert Ins, Insert Outs, and Direct Outs can also be patched by using the Encoders (see page 83).

See page 290 for a complete list of output patch sources. See page 297 for a list of initial output patches.

Output Patch settings can be stored in the Output Patch library, which contains 1 preset memory and 32 user memories. See “Output Patch Library” on page 167 for more information.

### Patching Slot Outputs

Bus Outs, Aux Sends, Matrix Sends, the Stereo Out, Input or Output Channel Insert Outs, or Surround Monitor Channels can be patched to the Slot Outputs. Slot Outputs can be patched to Direct Outs on the Direct Out Destination pages (see page 81).

The Slot Output Patch parameters for the six Slots are arranged into three pages. The Slot 1–2 Output Patch page is shown below. The layout of the other two pages is the same.

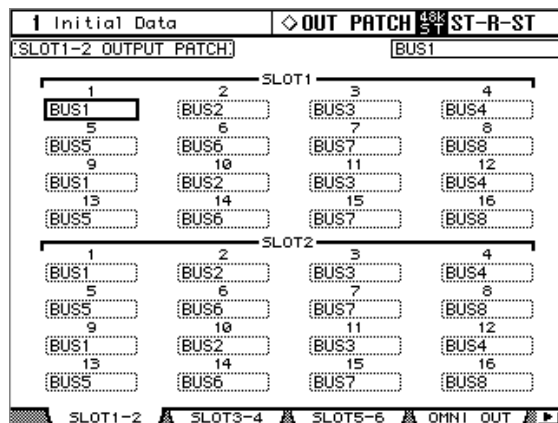

When a Slot Output is patched to a Direct Out (see page 81), and that Direct Out is assigned on an Input Channel Routing page, the Slot Output patch cannot be changed here. If the higher sampling rate (88.2 kHz/96 kHz) data format is set to Double Channel mode, the Slot’s even channel patch is disabled and cannot be changed.

## Patching Omni Outs

Bus Outs, Aux Sends, Matrix Sends, the Stereo Out, Input or Output Channel Insert Outs, or Surround Monitor Channels can be patched to the Omni Outs. Omni Outs can be patched to Direct Outs on the Direct Out Destination pages (see page 81).

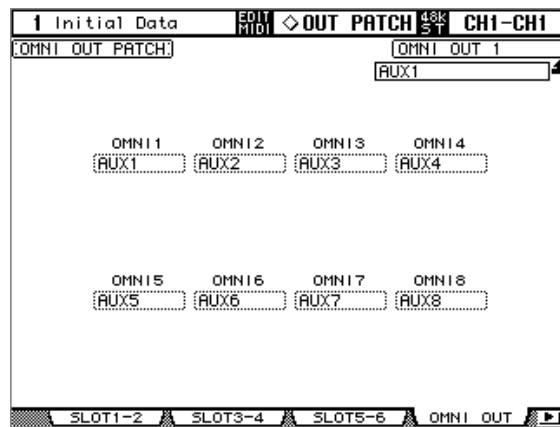

When an Omni Out is patched to a Direct out (see page 81), and that Direct Out is assigned on an Input Channel Routing page, the Omni Out patch cannot be changed here.

## Output Channel Inserts Ins

AD Inputs, Slot Inputs, internal effects processor outputs, or Digital or Analog 2TR Inputs can be patched to the Output Channel Insert Ins. The left and right channels of the Matrix Sends and the Stereo Out can be patched individually.

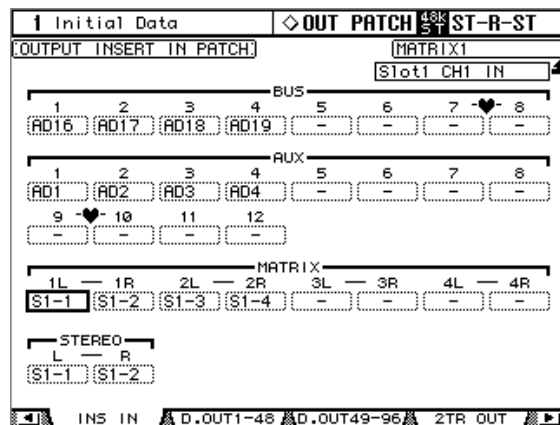

In addition to using the cursor buttons, Patch parameters can also be selected by using the [SEL] buttons.



### Patching Direct Outs

Direct Outs can be patched to the Slot Outputs, Omni Outs, or 2TR Digital Outputs.

The Direct Out Destination parameters for the 96 Input Channels are divided between two pages. The Input Channel 1–48 Direct Out Destination page is shown below. The layout of the other page is the same.

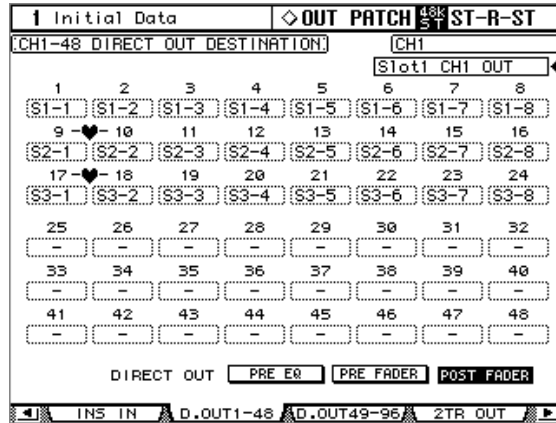

In addition to using the cursor buttons, Patch parameters can also be selected by using the [SEL] buttons.

### Patching the 2TR Digital Outputs

Bus Outs, Aux Sends, Matrix Sends, the Stereo Out, Input or Output Channel Insert Outs, or the Control Room signal can be patched to the 2TR Digital Outputs. 2TR Digital Outputs can be patched to Direct Outs on the Direct Out Destination pages (see page 81). The left and right channels of each Digital Output can be patched individually.

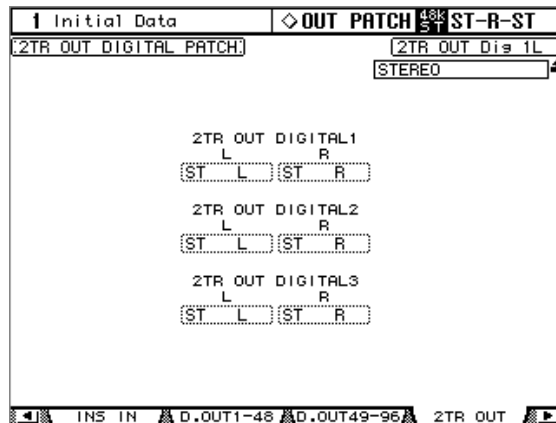

When a 2TR Digital Output is patched to a Direct out (see page 81), and that Direct Out is assigned on an Input Channel Routing page, the 2TR Digital Output patch cannot be changed here.

### Patching the GEQs

The six 31-band graphic equalizers can be inserted into the Bus Outs, Aux Sends, or the left or right channels of the Matrix Sends or Stereo Out on the Graphic Equalizer Insert page. GEQs can also be patched on the Graphic Equalizer Edit page (see page 183) or the Output Channel Insert page (see page 135).

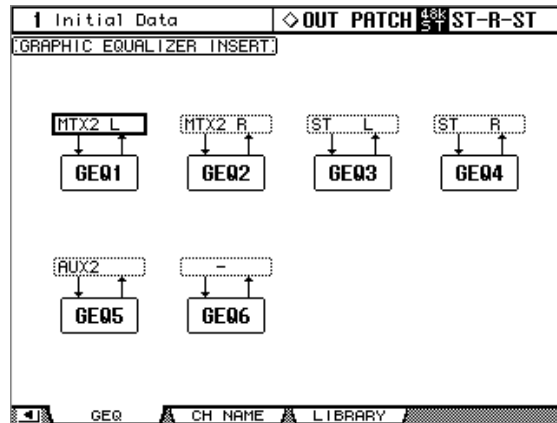

### Naming Input & Output Ports

You can specify Long and Short names for the Input and Output Ports as follows. These names appear on the Input and Output Patch pages and the channel strip displays when patching with the Encoders.

See page 300 for a list of the initial Input Port names; page 301 for Output Port names.

- 1 Use the DISPLAY ACCESS [SETUP] button to locate the Input Port or Output Port Name page.

ID	SHORT	LONG
AD17	<AD17>	<AD IN 17 >
AD16	<AD16>	<AD IN 16 >
AD15	<AD15>	<AD IN 15 >
AD14	<AD14>	<AD IN 14 >
AD13	<AD13>	<AD IN 13 >
AD12	<AD12>	<AD IN 12 >
AD11	<AD11>	<AD IN 11 >
AD10	<AD10>	<AD IN 10 >
AD9	<AD9 >	<AD IN 9 >
AD8	<AD8 >	<AD IN 8 >
AD7	<AD7 >	<AD IN 7 >
AD6	<AD6 >	<AD IN 6 >
AD5	<AD5 >	<AD IN 5 >

ID	SHORT	LONG
SLOT2-13	<S213 >	<Slot2 CH13 OUT >
SLOT2-12	<S212 >	<Slot2 CH12 OUT >
SLOT2-11	<S211 >	<Slot2 CH11 OUT >
SLOT2-10	<S210 >	<Slot2 CH10 OUT >
SLOT2-9	<S2-9 >	<Slot2 CH9 OUT >
SLOT2-8	<S2-8 >	<Slot2 CH8 OUT >
SLOT2-7	<S2-7 >	<Slot2 CH7 OUT >
SLOT2-6	<S2-6 >	<Slot2 CH6 OUT >
SLOT2-5	<S2-5 >	<Slot2 CH5 OUT >
SLOT2-4	<S2-4 >	<Slot2 CH4 OUT >
SLOT2-3	<S2-3 >	<Slot2 CH3 OUT >
SLOT2-2	<S2-2 >	<Slot2 CH2 OUT >
SLOT2-1	<S2-1 >	<Slot2 CH1 OUT >

- 2 Use the Parameter wheel or INC/DEC buttons to select the ports.
- 3 Use the cursor buttons to select the Long or Short name, and then press [ENTER].

When the Title Edit window appears, edit the port name, and press OK when you've finished. See "Title Edit Window" on page 54 for more information.

When the Name Input Auto Copy option is on, the first four characters of a newly entered Long name are automatically copied to the Short name and vice versa.

You can reset all port names back to their initial values by pressing the INITIALIZE button.

## Patch Select Window

Input and Output patches can be made by using the Patch Select window, shown below, which appears when the [ENTER] button is pressed while a patch parameter is selected.

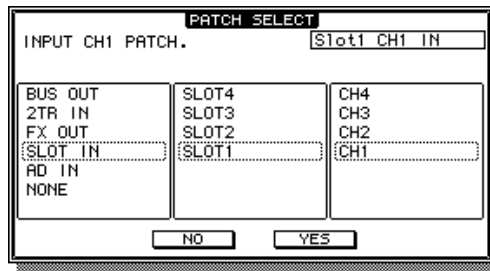

Available input and output sources and destinations are displayed in a hierarchical format in three panes. The existing source or destination is displayed in the upper-right corner of the window. Use the cursor buttons to move the cursor to the pane on the left, and use the Parameter wheel or INC/DEC buttons to select the top level item. Then move the cursor to the center pane, and select an item at the next level. Select an item in the right pane, if available, and then select the YES button and press [ENTER].

## Patching with the Encoders

The following patches can be made by using the Encoders: Input Channel Inputs, Insert Outs, Insert Ins, and Direct Outs.

- 1 Assign one of the above parameters to an Encoder ASSIGN button, as explained on page 62.**

To set the Input Channel Input or Direct Out patches, you must select an Input Channel Layer. For Insert Out or Insert In patches, you can select an Input Channel Layer or the Master Layer.

- 2 Press the ASSIGN button to which you assigned the patch parameter.**

If no further action is taken within five seconds, the channel strip displays return to normal, and you must press the ASSIGN button again.

Depending on the “Port ID/Name on FL Display” preference on page 276, the channel strip displays show the Port IDs or Short Port names for the current patches.



AD1

- 3 Use the Encoders to select ports, and press the Encoder push switches to set them.**

If you don't activate your selection within five seconds (i.e., while the Port ID or Short Channel name flashes), or you operate another Encoder, the selection is cancelled and the patch is left unchanged.

# 7 Input Channels

## Patching Input Channels

AD Inputs, Slot Inputs, internal effects processor outputs, Digital or Analog 2TR Inputs, Bus Outs, or Aux Sends can be patched to the Input Channel Inputs. See “Patching Input Channels” on page 77 for more information.

## Metering Input Channels

Input Channel signal levels can be metered on the Meter pages. See “Metering” on page 127 for more information.

## Reversing the Signal Phase

The signal phase of each Input Channel can be reversed as follows.

### Using the SELECTED CHANNEL PHASE/INSERT [ $\phi$ ] Button

- 1 Use the LAYER buttons to select Input Channel Layers, and use the [SEL] buttons to select Input Channels.
- 2 Use the Phase [ $\phi$ ] button to set the phase.

Phase is reversed when the Phase [ $\phi$ ] button indicator is lit.



### Phase Pages

Phase settings can be viewed and set on the Phase pages. If the Auto PHASE/INSERT Display preference is on, these pages appear automatically when you press the Phase [ $\phi$ ] button in the SELECTED CHANNEL PHASE/INSERT section, turning on the button indicator. See “Auto PHASE/INSERT Display” on page 274.

- 1 Use the SELECTED CHANNEL PHASE/INSERT [DISPLAY] button to select the Phase pages.

The Phase parameters for the 96 Input Channels are divided between two pages. The Input Channel 1–48 Phase page is shown below. The layout of the other page is the same.

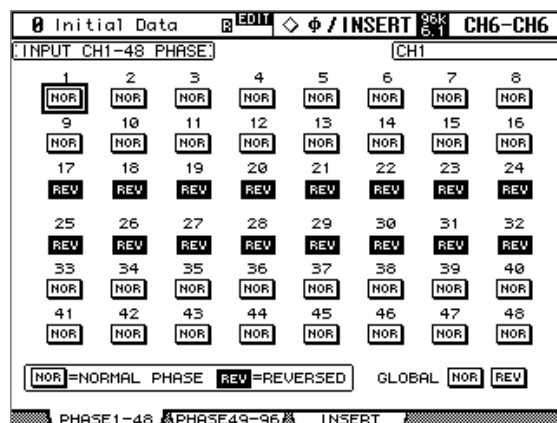

- 2 Use the cursor buttons or Parameter wheel to select the NOR/REV buttons, then use the [ENTER] button and INC/DEC buttons to set them.

The NOR/REV buttons can also be selected by using the [SEL] buttons.

**GLOBAL NOR/REV:** These buttons allow you to set the phase of all Input Channels simultaneously.

## Gating Input Channels

Each Input Channel features a noise Gate for automatically shutting out unwanted noise. Gate settings can be stored in the Gate library, which contains 4 preset memories and 124 user memories. See “Gate Library” on page 170 for more information.

### Preset Gates & Types

The following table lists the preset Gates and types. See page 333 for detailed parameter information.

#	Preset Name	Type	Description
1	Gate	GATE	Gate template
2	Ducking	DUCKING	Ducking template
3	A. Dr. BD	GATE	Gate preset for use with acoustic bass drums
4	A. Dr. SN	GATE	Gate preset for use with acoustic snare drums

### Using the SELECTED CHANNEL DYNAMICS Controls

- 1 Use the LAYER buttons to select Input Channel Layers, and use the [SEL] buttons to select Input Channels.
- 2 Use the [GATE ON] button to turn the currently selected Input Channel's Gate on or off.

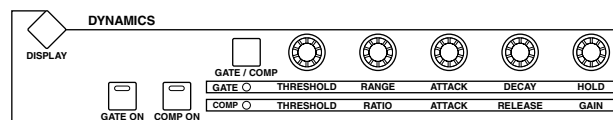

- 3 Use the [GATE/COMP] button to set the DYNAMICS controls to GATE (GATE indicator lit), and use the THRESHOLD, RANGE, ATTACK, DECAY, and HOLD controls to set the Gate.

## Gate Edit Page

Gate settings can be viewed and set on the Gate Edit page. If the Auto DYNAMICS Display preference is on, this page appears automatically when a gate control in the SELECTED CHANNEL DYNAMICS section is operated.

- 1 Use the **LAYER** buttons to select Input Channel Layers, and use the **[SEL]** buttons to select Input Channels.
- 2 Use the **SELECTED CHANNEL DYNAMICS [DISPLAY]** button to locate the **Gate Library** page, and then recall a Gate preset that contains the gate type that you want.

See “Gate Library” on page 170 for more information.

- 3 Use the **SELECTED CHANNEL DYNAMICS [DISPLAY]** button to locate the **Gate Edit** page.

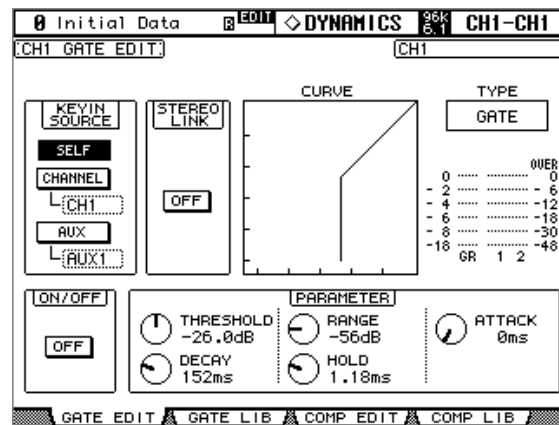

- 4 Use the cursor buttons to select the parameters, and use the **Parameter** wheel, **INC/DEC** buttons, and **[ENTER]** button to set them.

**KEYIN SOURCE:** This determines the trigger source for the currently selected Input Channel’s Gate. Trigger sources include SELF (the Gate’s own input signal), CHANNEL (another Input Channel), or AUX (an Aux Send from 1–12). Input Channel trigger sources are selectable in blocks of 12 channels. For example, if Input Channel #1 is currently selected, an Input Channel from 1–12 can be selected as the trigger source. However, if Input Channel #13 is currently selected, an Input Channel from 13–24 can be selected.

**STEREO LINK:** This allows you to pair Gates for stereo operation even when Input Channels are not paired. Input Channel Gates are paired either horizontally or vertically depending on the Pair mode setting for the currently selected Input Channel. See “Pairing Channels” on page 144 for more information on horizontal and vertical pairing. When Input Channels are paired, this parameter is turned on automatically and cannot be changed.

**CURVE:** This displays the gate curve (i.e., input level vs. output level).

**TYPE:** This is the gate type used by the currently selected Input Channel’s Gate.

**Meters:** These meters indicate the levels of the currently selected Input Channel and its horizontal or vertical partner. The GR meter indicates the amount of gain reduction being applied by the currently selected Input Channel’s Gate.

**ON/OFF:** This turns the currently selected Input Channel’s Gate on and off. It works in unison with the **SELECTED CHANNEL DYNAMICS [GATE ON]** button.

**PARAMETER:** These controls are used to set the Threshold, Range, Attack, Decay, and Hold parameters.

## Attenuating Input Channels

Input Channels signals can be attenuated pre-EQ. See “Attenuating Signals” on page 130 for more information.

## EQ'ing Input Channels

Each Input Channel features 4-band parametric EQ. See “Using EQ” on page 131 for more information.

## Grouping Input Channel EQs

Input Channel EQs can be grouped, allowing you to control the EQ of several Input Channels simultaneously. There are four Input Channel EQ groups: a, b, c, and d.

- 1 Use the **DISPLAY ACCESS [GROUP]** button to locate the **Input Equalizer Link** page.

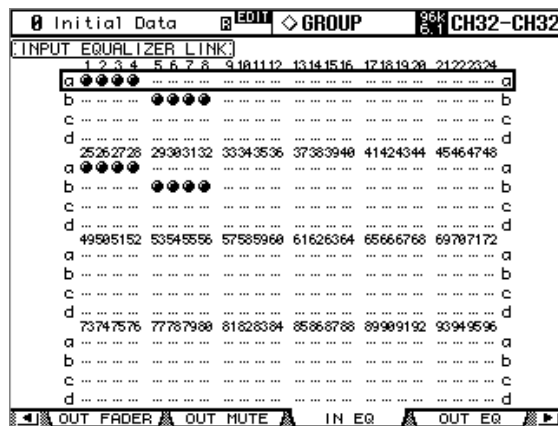

- 2 Use the **LAYER** buttons to select the **Input Channel Layers**.  
The corresponding group row is selected as each Input Channel Layer is selected.
- 3 Use the **Up/Down cursor** buttons to select **EQ groups a–d**.  
The selected group is highlighted by a flashing cursor box.
- 4 Use the **[SEL]** buttons to add and remove **Input Channels** to and from the selected group.  
The EQ settings of the first Input Channel added to the group are applied to all subsequently added Input Channels.  
When an Input Channel is added to a group, its **[SEL]** button indicator lights up.

## Input Channel Inserts

Internal effects processors and external signal processors can be patched into the Input Channels by using the Inserts. See “Using Inserts” on page 135 for more information.

## Compressing Input Channels

Each Input Channel features a Compressor. See “Compressing Channels” on page 137 for more information.

## Grouping Input Channel Compressors

Input Channel Compressors can be grouped, allowing you to control the compression of several Input Channels simultaneously by operating any Compressor control in the group. There are four Input Channel Compressor groups: i, j, k, and l.

- 1 Use the **DISPLAY ACCESS [GROUP]** button to locate the **Input Comp Link** page.

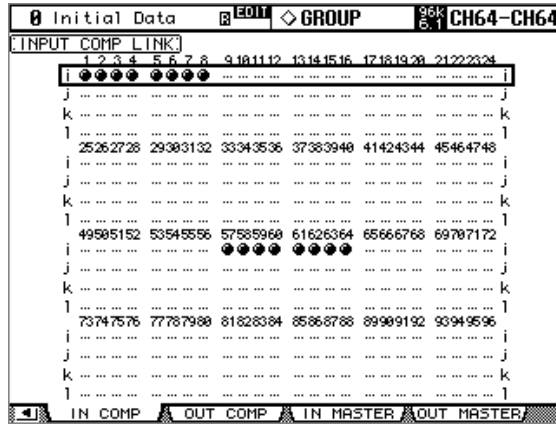

- 2 Use the **LAYER** buttons to select the **Input Channel Layers**.  
The corresponding group row is selected as each Input Channel Layer is selected.
- 3 Use the **Up/Down** cursor buttons to select **Comp groups i-l**.  
The selected group is highlighted by a flashing cursor box.
- 4 Use the **[SEL]** buttons to add and remove **Input Channels** to and from the selected group.  
The Compressor settings of the first Input Channel added to the group are applied to all subsequently added Input Channels.  
When an Input Channel is added to a group, its **[SEL]** button indicator lights up.

## Delaying Input Channels

Each Input Channel features a Delay function. See “Delaying Channel Signals” on page 141 for more information.

## Muting Input Channels (ON/OFF)

Input Channels can be muted as follows.

- 1 Use the **LAYER** buttons to select the **Input Channel Layers**.
- 2 Use the **[ON]** buttons to mute the **Input Channels** on the selected **Layer**.



The **[ON]** button indicators of channels that are on are lit.



## Grouping Input Channel Mutes (ON/OFF)

Input Channel Mutes can be grouped, allowing you to mute several Input Channels simultaneously. There are eight Input Channel Mute groups: I, J, K, L, M, N, O, and P.

- 1 Use the **DISPLAY ACCESS [GROUP]** button to locate the Input Channel Mute Group pages.

The Mute group parameters for the 96 Input Channels are divided between two pages. The Input Channel 1–48 Mute Group page is shown below. The layout of the other page is the same.

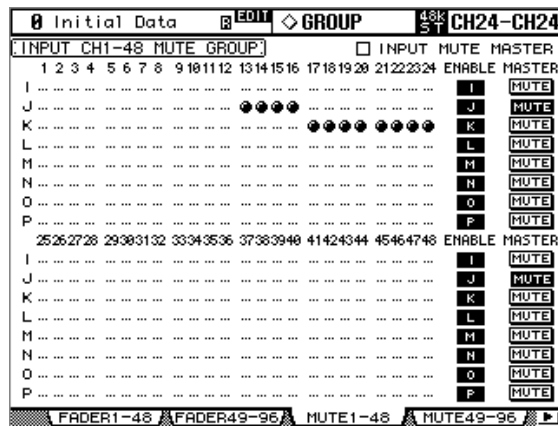

- 2 Use the **LAYER** buttons to select the Input Channel Layers.

The corresponding Mute Group page and group row is selected as each Input Channel Layer is selected.

- 3 Use the **Up/Down** cursor buttons to select Mute groups I–P.

The selected group is highlighted by a flashing cursor box.

- 4 Use the **[SEL]** buttons to add and remove mutes to and from the selected group.

When an Input Channel is added to a Mute group, its [SEL] button indicator lights up.

**ENABLE:** These buttons are used to enable and disable the groups.

**INPUT MUTE MASTER:** When this check box is checked, clicking a MASTER MUTE button mutes or unmutes all channels in the corresponding Mute group. When this check box is unchecked, the Input Channel [ON] button status links to the mute on/off status of the channels in the group.

**MASTER MUTE:** When the Input Mute Master check box is checked, use this button to mute or unmute all channels in the corresponding Mute group.

When the Input Mute Master check box is unchecked, pressing the Input Channel [ON] button mutes or unmutes the channels in the corresponding Mute group (Mute On channels turn off and Mute Off channels turn on).

## Input Channel Mute Master

The DM2000 features a Mute Master function that enables you to mute all channels in the Mute group using the MASTER button, much like a Mute group on an analog mixing console. When the Mute Master function is enabled, the channel [ON] button status does not link to the corresponding Mute group.

- 1 **Follow Steps 1–4 as described in the “Grouping Input Channel Mutes (ON/OFF)” section on the previous page, select the Input Mute Master check box, then press the [ENTER] button to check or uncheck the Input Mute Master check box.**
- 2 **When the Input Mute Master check box is checked, the MASTER MUTE button for each Mute group turns mute on or off for the channels in the corresponding Mute group.**

If the channels are muted by the Mute Master function, the corresponding channel [ON] button indicators flash. You can assign the MASTER MUTE button function to one of the USER DEFINED KEYS for convenient operation.

## Setting Input Channel Levels

Input Channel levels can be set as follows.

- 1 **Use the LAYER buttons to select the Input Channel Layers.**
- 2 **Press the FADER MODE [FADER] button to select Fader mode.**
- 3 **Use the faders to set the Input Channel levels.**

Refer to the legend on the left side of the faders when setting Input Channel levels.

You can view the fader level values on the channel strip displays while you operate the faders.

You can also view fader positions on the Fader View pages, which you can access by pressing the DISPLAY ACCESS [VIEW] button. See “Viewing Channel Fader Settings” on page 151 for more information.

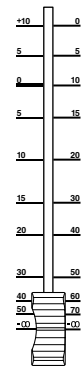

## Grouping Input Channel Faders

Input Channel faders can be grouped, allowing you to control the level of several Input Channels simultaneously. There are eight Input Channel Fader groups: A, B, C, D, E, F, G, and H.

- 1 Use the **DISPLAY ACCESS [GROUP]** button to locate the Input Channel Fader Group pages.

The Fader Group parameters for the 96 Input Channels are divided between two pages. The Input Channel 1–48 Fader Group page is shown below. The layout of the other page is the same.

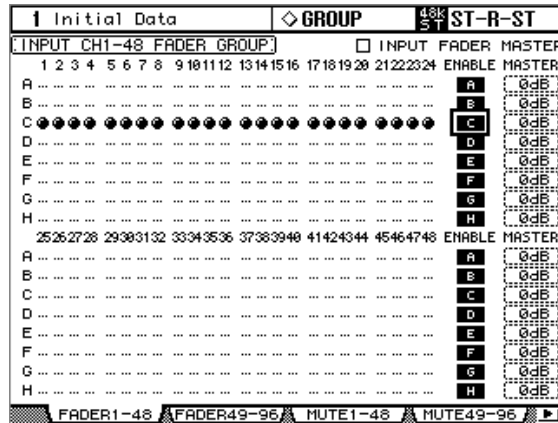

- 2 Use the **LAYER** buttons to select the Input Channel Layers.

The corresponding Fader Group page and group row is selected as each Input Channel Layer is selected.

- 3 Use the **Up/Down** cursor buttons to select Fader groups A–H.

The selected group is highlighted by a flashing cursor box.

- 4 Use the **[SEL]** buttons to add and remove faders to and from the selected group.

When an Input Channel is added to a group, its [SEL] button indicator lights up.

**ENABLE:** These buttons are used to enable and disable the groups.

**INPUT FADER MASTER:** When this check box is unchecked, the Input Channel fader positions link to the fader levels for the channels in the corresponding Fader group. When this check box is checked, you can set the master level for the corresponding Input Channel Fader group in the Master column. The resultant Input Channel level equals the corresponding Input Channel fader level plus the Group Master level. See “Group Master for Input Channel Faders” on page 92.

When the Input Fader Master check box is not checked, operating the channel faders will affect the input levels for the corresponding Fader group. Pressing and holding down the [SEL] button while operating the fader of an Input Channel will temporarily cancel the corresponding Fader group, which is convenient if you want to adjust the relative balance between channels.

Fader groups are active only in Fader mode (i.e., when the FADER MODE [FADER] button indicator is on). See “Selecting Fader Modes” on page 60 for more information.

## Group Master for Input Channel Faders

The DM2000 features a Fader Group Master function that enables you to control the level of all channels using the Group Master level while maintaining the relative balance between channels, much like a VCA group on an analog mixing console. While this function is enabled, channel fader operation does not affect channel levels in the corresponding Fader group.

- 1 Follow Steps 1-4 as described in the “Grouping Input Channel Faders” section on the previous page, select the Input Fader Master check box, then press the [ENTER] button to check or uncheck the Input Fader Master check box.
- 2 When the Input Fader Master check box is checked, you can set channel levels of the Fader groups in the Master column.

When the Master column is selected, repeatedly pressing the [ENTER] button turns the Input Fader group on and off.

You can also make these settings in the Input Fader Group Master page, as shown below.

- 3 Use the DISPLAY ACCESS [GROUP] button to locate the Input Fader Group Master page.

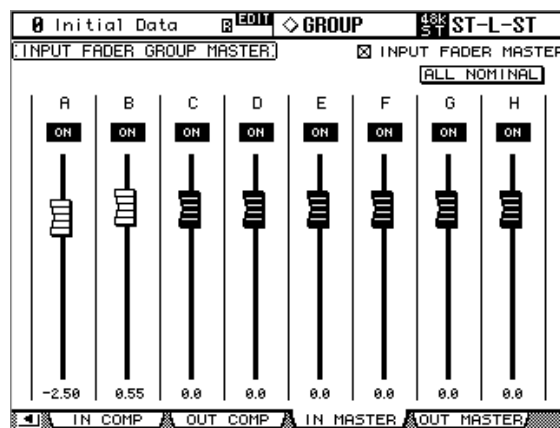

- 4 Use the cursor buttons to select parameters, then use the Parameter wheel, INC/DEC buttons, or [ENTER] button to set the parameters.

**INPUT FADER MASTER:** When this check box is checked, you can set the master levels for the Input Fader groups. The resultant Input Channel level equals the corresponding Input Channel fader level plus the Group Master level.

**ALL NOMINAL:** This button resets the master levels for all Input Fader groups to nominal.

**ON/OFF:** This turns each Input Fader group on or off. This function works like a VCA mute on an analog mixing console.

**Faders:** These faders adjust the master levels of the Fader groups. Fader knobs are highlighted when faders are set to 0.0 dB. Press the [ENTER] button to set the currently-selected fader to 0.0 dB.

You can also control the parameters from the channel strips on the control surface as described below by using the User Assignable Layer of the Remote Layers. See page 269 for information on the User Assignable Layer.

**Encoders:** The Encoders are not available.

**[AUTO] buttons:** These buttons are used to control the Fader Group Master On/Off and the master level during Automix.

**[SEL] buttons:** These buttons move the cursor on the Input Fader Group Master page.

**[SOLO] buttons:** These buttons turn the Solo function of each Fader group on and off. You can monitor all the channels in each Fader group.

**Channel Strip Displays:** The displays indicate the Group names (GrpA – GrpH). When you operate the channel faders, the displays indicate the corresponding master level values.

**Channel Faders:** The channel faders enable you to set the master level for each Fader group.

## Routing Input Channels

Each Input Channel can be routed to the Bus Outs, Stereo Out, or its own Direct Out.

### Using the SELECTED CHANNEL ROUTING Controls

- 1 Use the **LAYER** buttons to select the Input Channel Layers, and use the **[SEL]** buttons to select the Input Channels.
- 2 Use the **[1–8]**, **[STEREO]**, and **[DIRECT]** buttons to route the currently selected Input Channel.

**[1–8]:** These buttons route the currently selected Input Channel to the Bus Outs.

**[STEREO]:** This button routes the currently selected Input Channel to the Stereo Out.

**[DIRECT]:** This button routes the currently selected Input Channel to its Direct Out.

**[FOLLOW PAN]:** This determines whether the Input Channel's Pan control setting is applied to the Bus Outs. When off, the levels of the signals fed to the odd and even Bus Outs is the same. When on, the levels of the signals fed to the odd and even Bus Outs follows the Pan control.

In Surround mode, when this button is turned off, the surround pan setting does not affect signals fed to the Bus Outs. You can enable the surround pan setting when the input source is monaural, and patch the surround sources or surround effects directly to the Surround Buses.

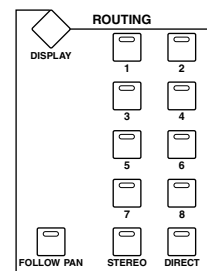

### Routing Pages

Input Channel routing settings can be viewed and set on the Routing pages. If the Auto ROUTING Display preference is on, these pages appear automatically when a button in the SELECTED CHANNEL ROUTING section is pressed. See “Auto ROUTING Display” on page 274.

- 1 Use the SELECTED CHANNEL ROUTING [DISPLAY] button to select the Routing pages.

The Routing parameters for the 96 Input Channels are divided among four pages. The Input Channel 1–24 Routing page is shown below. The layout of the other three pages is the same.

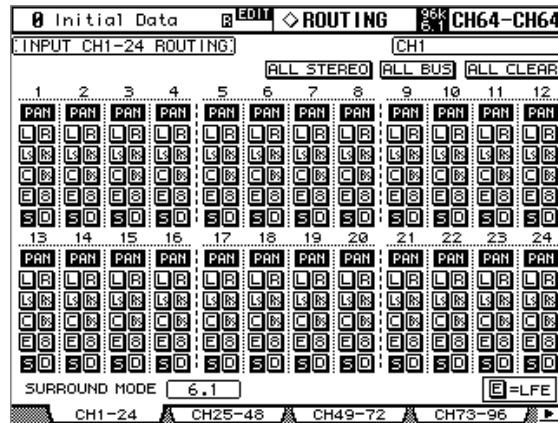

- 2 Use the cursor buttons and Parameter wheel to select the parameters, and use the [ENTER] button or INC/DEC buttons to set them.

Channels can also be selected by using the Input Channel Layer buttons and [SEL] buttons.

**ALL STEREO:** This button assigns all Input Channels that are currently displayed to the Stereo Out.

**ALL BUS:** This button assigns all Input Channels that are currently displayed to all Bus Outs

**ALL CLEAR:** This button clears all routing assignments that are currently displayed.

The currently selected Surround mode is displayed in the lower-left corner. When Stereo mode is selected, the Bus Out routing buttons display numbers from 1 through 8. When a Surround Pan mode is selected, they display abbreviations of the Surround Channel names, as shown in the following table. See “Using Surround Pan” on page 97 for more information.

Surround Mode	Bus Outs							
	1	2	3	4	5	6	7	8
Stereo	1	2	3	4	5	6	7	8
3-1	L	R	C	S	5	6	7	8
5.1	L	R	Ls	Rs	C	E <sup>1</sup>	7	8
6.1	L	R	Ls	Rs	C	Bs	E	8

1. Short for LFE (Low frequency Effects).

This table shows the default assignments. The actual assignments may vary depending on the settings on the Surround Bus Setup page. See “Assigning Surround Channels to Buses” on page 99 for more information.

## Panning Input Channels

Input Channels can be panned between the left and right channels of the Stereo Out.

### Using the Encoders

- 1 Use the LAYER buttons to select the Input Channel Layers.
- 2 Press the ENCODER MODE [PAN] button to select the Pan Encoder mode.
- 3 Use the Encoders to pan the input channels.



### Using the SELECTED CHANNEL PAN/SURROUND Controls

- 1 Use the LAYER buttons to select the Input Channel Layers, and use the [SEL] buttons to select the Input Channels.

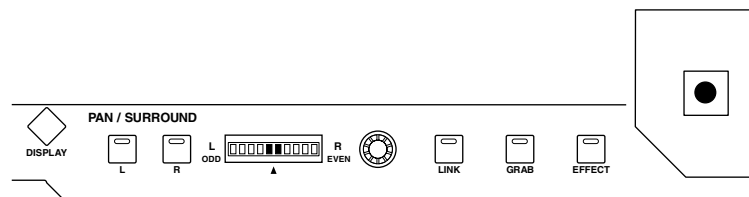

- 2 Use the Pan control to pan the currently selected Input Channel.

The pan display indicates the pan position of the currently selected Input Channel. When pan is set to center, the center two segments light up. You can use the [L] and [R] buttons to select horizontal or vertical Input Channel partners.

The [LINK] button, which is enabled only when a Surround mode other than Stereo is selected, is used to link the Pan control and the Joystick so that either control can be used for panning. This setting applies only to Input Channels that are currently selected. For this to work, the [EFFECT] button indicator must be off and the [GRAB] and [LINK] button indicators must be on.

### Pan Pages

Pan settings can be viewed and set on the Pan pages. If the Auto PAN/SURROUND Display preference is on, these pages appear automatically when a control in the SELECTED CHANNEL PAN/SURROUND section is operated.

- 1 Use the **SELECTED CHANNEL PAN/SURROUND [DISPLAY]** button to select the **Input Channel Pan** pages.

The Pan parameters for the 96 Input Channels are arranged into four pages. The Input Channel 1–24 Pan page is shown below. The layout of the other three pages is the same.

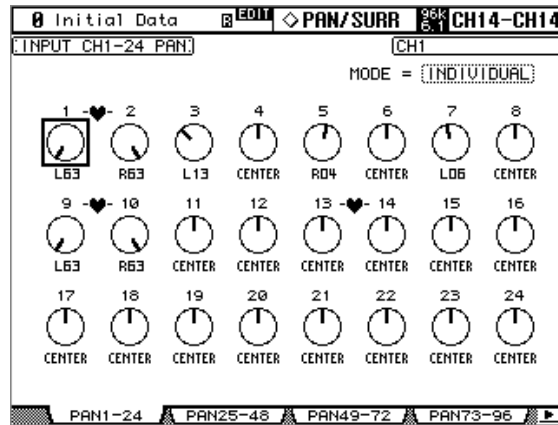

- 2 Use the cursor buttons to select the Pan controls, and use the Parameter wheel and INC/DEC buttons to set them.

Pan parameters can also be selected by using the Input Channel Layer buttons and [SEL] buttons.

The currently selected Pan control can be set to center by pressing [ENTER].

**MODE:** There are three Pan modes that determine how horizontally and vertically paired Input Channels are panned: Individual, Gang, and Inverse Gang. This is a global setting that applies to all paired Input Channels.

 In individual mode, paired Input Channel pan controls operate independently.

 In Gang mode, paired Input Channel pan controls operate in unison.

 In Inverse Gang mode, paired Input Channel pan controls operate in unison but move in opposite directions.

Aux Send Pan controls can be linked to Input Channel Pan controls so that operating an Input Channel Pan control also operates the corresponding Aux Send Pan control, and vice versa (see page 116). While linked, the Pan mode can be set on the Aux Pan page or the Input Channel Pan page.

*Note: While the PAN/SURROUND [LINK] button is turned on, the Pan mode is automatically set to Individual. When the Pan mode is switched from Gang mode to Inverse Gang mode, the [LINK] button is turned off.*



## Using Surround Pan

The DM2000 supports 3-1, 5.1 and 6.1 Surround modes. Surround pan is independent of normal panning. Normal panning determines how the Input Channel signal is panned between the left and right channels of the Stereo out. Whereas surround panning determines how the Input Channel signal is panned among the Surround channels (i.e., the Bus Outs).

If Input Channel Follow Pan is off, you can patch signals to the corresponding Bus Outs without being affected by the surround pan setting. This is useful when you want to assign the surround source or surround effect return to Bus Outs.

When the Nominal Pan preference is on (see page 275), signals will be at nominal level when panned hard left or hard right, and at +3 dB when the preference is turned off.

*Note: If you have saved a scene with the Follow Pan function turned off on a DM2000 that is older than Version 2.0, the surround setting may not be reproduced*

The following table shows how Surround channels are handled by the Bus Outs.

The table may vary depending on the settings on the Surround Bus Setup page (see page 99).

Surround Mode	Bus Outs						
	1	2	3	4	5	6	7
3-1	L	R	C	S	—	—	—
	Front left	Front right	Center	Surround			
5.1	L	R	Ls	Rs	C	LFE	—
	Front left	Front right	Rear left	Rear right	Center	Subwoofer	
6.1	L	R	Ls	Rs	C	Bs	LFE
	Front left	Front right	Rear left	Rear right	Center	Rear center	Subwoofer

### Selecting Surround Pan Modes

The Surround mode can be selected as follows.

- 1 Use the **SELECTED CHANNEL PAN/SURROUND [DISPLAY]** button to select the **Surround Mode** page.

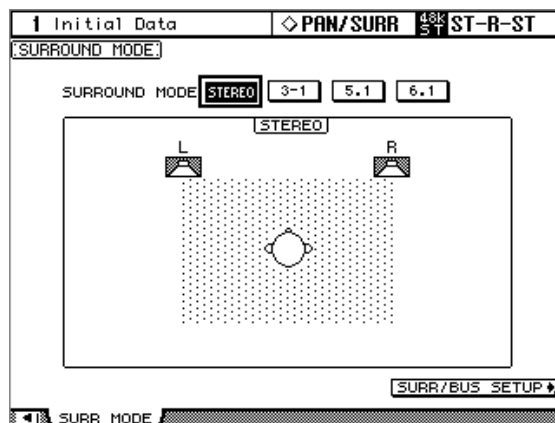

- Use the cursor buttons to select the surround mode buttons, and press [ENTER] to activate the selected mode.

The diagram on each page shows the typical sound image placement and the Surround channel to Bus Out configuration.

3-1 Surround

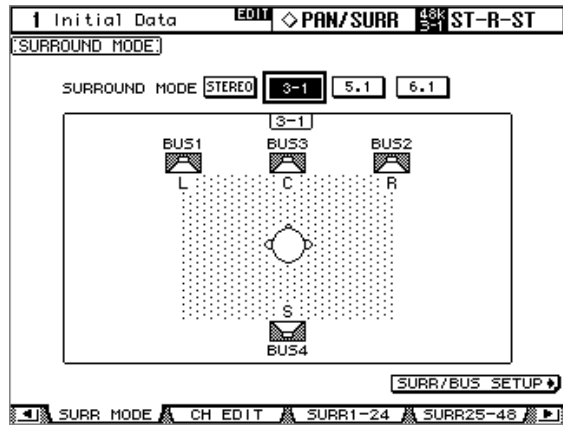

5.1 Surround

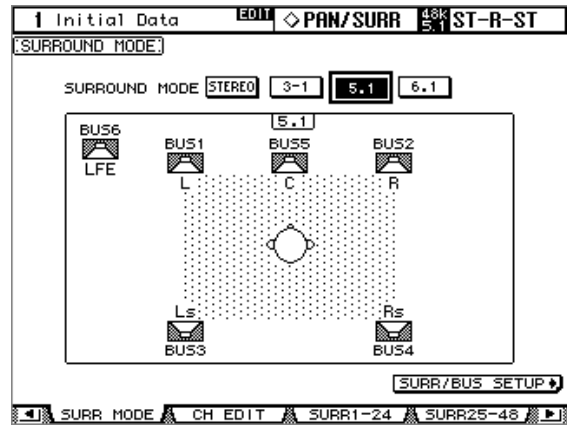

6.1 Surround

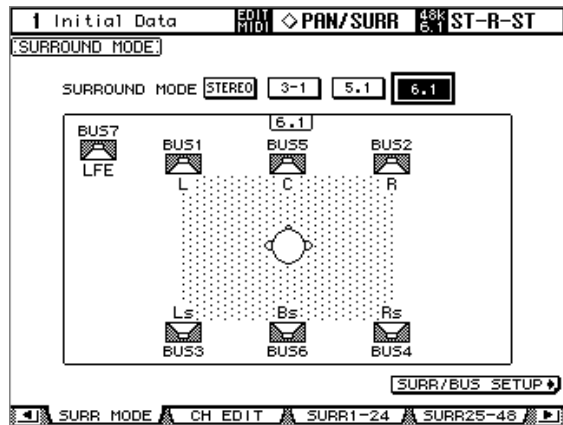

Select the SURR/BUS SETUP button, then press the [ENTER] button to display the Surround Bus Setup page, which enables you to change the Surround Channel to Bus Out assignment. See “Assigning Surround Channels to Buses” on page 99 for more information on the Surround Bus Setup page.

## Assigning Surround Channels to Buses

You can modify the Surround Channel to Bus assignment.

- 1 Use the **DISPLAY ACCESS [SETUP]** button to locate the Surround Bus Setup page.

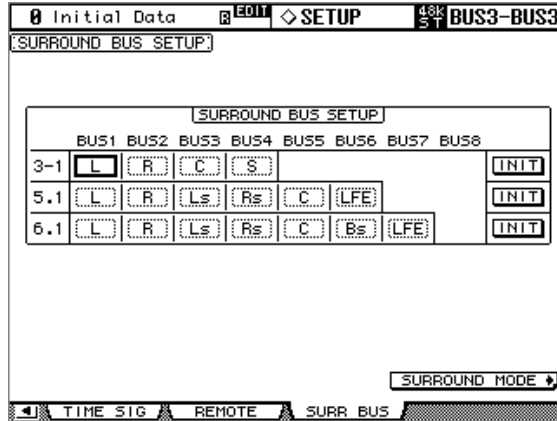

- 2 Use the cursor buttons to select the bus for which you want to change the surround channel assignment, then use the Parameter wheel or INC/DEC buttons to select a surround channel.

**INIT:** These buttons reset the channel assignment to the default setting.

## Using the Joystick

- 1 Use the **LAYER** buttons to select the Input Channel Layers, and use the **[SEL]** buttons to select the Input Channels.

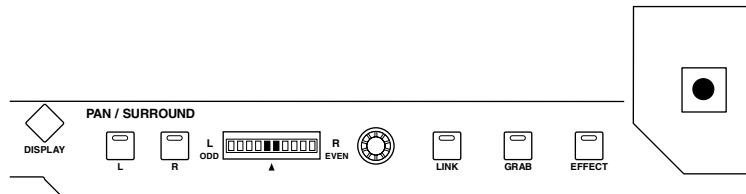

- 2 Press the **[GRAB]** button to grab the current Joystick position, and then use the Joystick to set the surround pan.

This is used to turn on and off Joystick surround pan control for the currently selected Input Channel. While Grab is on, the Joystick can be used to set the surround pan position of the currently selected Input Channel. If the Joystick is set to control effects (i.e., the **[EFFECT]** button indicator is lit), the **[GRAB]** button is disabled.

## Selected Channel Surround Edit Page

Surround pan settings can be viewed and set on the Input Channel Surround Edit page. If the Auto PAN/SURROUND Display preference is on, and a Surround Pan mode other than Stereo is selected, this page appears automatically when a PAN/SURROUND control other than the [EFFECT] button is operated. See “Auto PAN/SURROUND Display” on page 275.

- 1 Use the **SELECTED CHANNEL PAN/SURROUND [DISPLAY]** button to select the Surround Edit page.

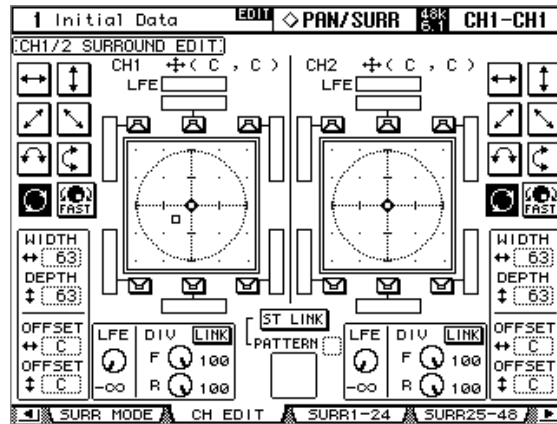

- 2 Use the **LAYER** buttons to select the Input Channel Layers, and use the **[SEL]** buttons to select the Input Channels.

The Surround Edit page displays surround pan parameters for the currently selected Input Channel and its horizontal or vertical partner. The current surround pan position of each Input Channel is indicated by a small circle. It's also indicated numerically next to each Input Channel number, for example, “CH1 (L9, R10).”

The graph of the currently selected Input Channel displays a small square, which indicates the current position of the Joystick. If the Auto Grab preference is on (see page 276), when the Joystick is moved to the current surround pan position, the Joystick kicks in as surround pan control and the small square disappears.

The number of speaker icons and meters around the surround graph depends on the currently selected Surround mode. The meters indicate Bus Out signal levels.

You can move the surround pan directly to one of the speaker icons, including the box icons without speakers, by selecting its icon, and then pressing [ENTER].

- 3 Use the **cursor** buttons to select the parameters, and use the **Parameter wheel, INC/DEC** buttons, and **[ENTER]** button to set them.

**Patterns:** These buttons are used to select the seven patterns that determine how the surround pan moves by the Parameter wheel and INC/DEC buttons.

**FAST:** This sets the speed of surround pan control when using the Parameter wheel and INC/DEC buttons.

**WIDTH:** This sets the left-to-right width of the selected pattern.

**DEPTH:** This sets the front-to-rear depth of the selected pattern.

**WIDTH OFFSET:** This can be used to offset the left-to-right direction of the selected pattern.

**DEPTH OFFSET:** This can be used to offset the front-to-rear direction of the selected pattern.

**LFE:** This sets the level of the LFE (Low Frequency Effects) Channel (5.1 and 6.1 mode only).

**DIV (divergence):** This determines how the Center signal is fed to the Left, Right, and Center channels. When set to 0, the Center signal is fed only to the Left and Right channels (i.e., Phantom Center). When set to 50, the Center signal is fed equally to the Left, Right, and Center channels. When set to 100, it's fed to only the Center channel (i.e., Real Center) (3-1 and 5.1 mode only).

**DIV F/R:** The F parameter control determines how the Front Center signal is fed to the Left and Right channels. The R parameter control determines how the rear surround signal is fed to the Left and Right surround channels (only for 6.1 surround).

**DIV LINK:** When DIV LINK is on, the F and R parameter controls are set to the same value and linked to each other (only for 6.1 Surround).

**ST LINK:** This can be used to link the surround pan parameters of the currently selected Input Channel and its horizontal or vertical partner regardless of whether they are paired.

**PATTERN:** When Input Channels are linked, the eight patterns selectable here determine how the linked surround pan moves by the Parameter wheel and INC/DEC buttons.

### Input Channel Surround Pages

Surround pan positions can be viewed and set on the Surround pages.

- 1 Use the **SELECTED CHANNEL PAN/SURROUND [DISPLAY]** button to select the **Input Channel Surround** pages.

The Surround parameters for the 96 Input Channels are arranged into four pages. The Input Channel 1–24 Surround page is shown below. The layout of the other three pages is the same.

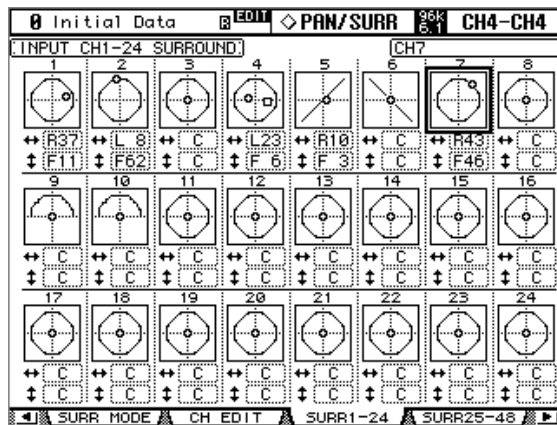

- 2 Use the cursor buttons to select the Surround parameters, and use the Parameter wheel and INC/DEC buttons to set them.

Input Channels can also be selected by using the Input Channel Layer buttons and [SEL] buttons. The graph for the currently selected Input Channel displays a small square, which indicates the current position of the Joystick.

**L/R:** These parameters are used to set the left/right surround position. While selected, they can quickly be set to center by pressing [ENTER].

**F/R:** These parameters are used to set the front/rear surround position. While selected, they can quickly be set to center by pressing [ENTER].

You can jump to the more detailed Surround Edit page by pressing [ENTER] while an Input Channel's surround graph is selected.

## **Sending Input Channels to Aux Sends**

Input Channel signals can be sent to Aux Sends 1–12. See “Setting Aux Send Levels” on page 111, “Muting Aux Sends (ON/OFF)” on page 112, and “Pre-Fader or Post-Fader Aux Sends” on page 111.

## **Soloing Input Channels**

Input Channels can be soloed. See page 142 for more information.

## **Direct Outs**

Each Input Channel features a Direct Out, which can be patched to the Slot Outputs, Omni Outs, or the 2TR Digital Outputs. Direct Out signals can be sourced pre-EQ, pre-fader, or post-fader. See “Patching Direct Outs” on page 81 and “Routing Input Channels” on page 93 for more information.

## **Pairing Input Channels**

Horizontal or vertical Input Channel partners can be paired for stereo operation. See “Pairing Channels” on page 144 for more information.

## **Viewing Input Channel Settings**

Parameter and fader settings for each Input Channel can be viewed on the View pages. See “Viewing Channel Parameter Settings” on page 150 and “Viewing Channel Fader Settings” on page 151 for more information.

## **Copying Input Channel Settings**

Input Channel settings can be copied to other Input Channels by using the Channel Copy function. See “Copying Channel Settings” on page 155 for more information.

## **Naming Input Channels**

Input Channels can be named for easy identification. See “Naming Channels” on page 156 for more information.

## Using the MS Stereo Microphone

The MS system is a type of stereo recording that uses two microphones: mono-directional M (Middle) and bi-directional S (Side) microphones. An M microphone picks up main signals, and an S microphone picks up directional signals. These two signals are decoded by calculating a sum (M plus S) and a difference (M minus S), and are recorded to L and R channels.

An MS microphone is usually a stereo microphone that features both M and S functions. To use an MS microphone, do the following:

- 1 Connect the L connector of an MS microphone to an odd channel input jack, and the R connector to an even channel input jack.**

Signals from the MS microphone are input from the L and R connectors. To use an MS microphone with the DM2000, connect the L connector to the input jack of an odd Input Channel, and connect the R connector to the input jack of the partner channel.

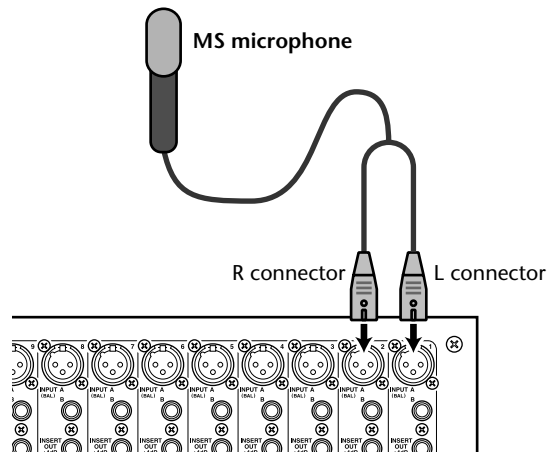

- 2 Use the DISPLAY ACCESS [PAIR] button to locate the Pair pages.**
- 3 Turn on the MS button for the channels to which the MS microphone is connected.**

The two channels are automatically paired and MS Decoding is turned on. With MS Decoding turned on, the faders and Encoders (Pan parameters) function as follows:

- **Odd-channel faders**.....M level (Controls the volume level.)
- **Odd-channel Encoders** .....ML/MR balance
- **Even-channel faders** .....S level (Controls the left and right directional spread.)
- **Even-channel Encoders** .....SL/SR balance

- 4 Use the faders and Encoders to adjust the MS microphone level and balance.**

When the signals are routed to paired Buses or the Stereo Bus, a sum of signals (ML plus SL) is sent to the odd-numbered Bus, and a difference of signals (ML minus SL) is sent to the even-numbered Bus.

## 8 Stereo Out

### Stereo Out Connectors

The Stereo Out is output by the STEREO OUT +4 dB (BAL) balanced XLR-3-32-type connectors and the STEREO OUT –10 dBV (UNBAL) unbalanced phono connectors.

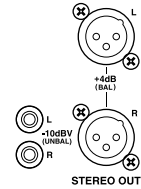

### Patching the Stereo Out to Outputs

The left and right channels of the Stereo Out can be patched to the Slot Outputs, Omni Outs, or the 2TR Digital Outputs. See “Output Patching” on page 79 for more information.

### Routing Input Channels to the Stereo Out

Input Channels can be routed and panned to the Stereo Out. See “Routing Input Channels” on page 93 for more information.

### Sending Bus Outs to the Stereo Out

Bus Out signals can be sent to the Stereo Out. See “Sending Bus Outs to the Stereo Out” on page 109 for more information.

### Metering the Stereo Out

Stereo Out signal levels can be metered on the Meter pages. See “Metering” on page 127 for more information.

### Monitoring the Stereo Out

The Stereo Out can be monitored via the LARGE and SMALL CONTROL ROOM MONITOR OUTs and the PHONES (see page 158) or the STUDIO MONITOR OUT (see page 159).

### Attenuating the Stereo Out

Stereo Out signals can be attenuated pre-EQ. See “Attenuating Signals” on page 130 for more information.

### EQ'ing the Stereo Out

The Stereo Out features 4-band parametric EQ. See “Using EQ” on page 131 for more information.

### Grouping Master EQs

The Stereo Out EQ can be grouped with the EQs of other Output Channels. See “Grouping Output Channel EQs” on page 135 for more information.

### Stereo Out Inserts

Internal effects processors and external signal processors can be patched into the Stereo Out by using the Inserts. See “Using Inserts” on page 135 for more information.



## Compressing the Stereo Out

Signal dynamics can be controlled by using the Stereo Out Compressor. See “Compressing Channels” on page 137 for more information.

## Grouping Master Compressors

The Stereo Out Compressor can be grouped with the Compressors of other Output Channels. See “Grouping Output Channel Compressors” on page 140 for more information.

## Muting the Stereo Out (ON/OFF)



The Stereo Out can be muted by using the STEREO [ON] button, which is used exclusively for this task and is not affected by the Layers. Its indicator lights up when the Stereo Out is on.

## Grouping Master Mutes (ON/OFF)

The Stereo Out Mute can be grouped with the Mutes of other Output Channels. See “Grouping Output Channel Mutes (ON/OFF)” on page 149 for more information.

## Setting the Stereo Out Level

The Stereo Out level is set by using the STEREO fader, which is used exclusively for this task and is not affected by the Layers or Fader modes.

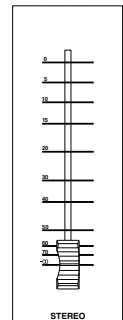

## Grouping Master Faders

The Stereo Out fader can be grouped with the faders of other Output Channels. See “Grouping Output Channel Faders” on page 146 for more information.

## Sending the Stereo Out to the Matrix Sends

The left and right channels of the Stereo Out can be sent individually to the Matrix Sends. See “Matrix Sends” on page 121 for more information.

## Balancing the Stereo Out

The left and right channels of the Stereo Out can be balanced as follows.

- 1 **Press the STEREO [SEL] button to select the Stereo Out.**

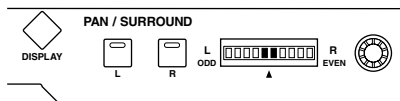

- 2 **Use the Pan control to set the balance.**

The pan display indicates the balance. When the balance is set to center, the center two segments light up.

The Stereo Out balance can also be set on the Stereo Fader View page. See “Viewing Channel Fader Settings” on page 151 for more information.

## Delaying the Stereo Out

The left and right channels of the Stereo Out can be delayed independently by using the Stereo Out Delay. See “Delaying Channel Signals” on page 141 for more information.

## Inserting GEQs

Internal GEQs can be inserted into the left and right channels of the Stereo Out. See “About the GEQs” on page 183 for more information.

## Viewing Stereo Out Settings

Parameter and fader settings for the Stereo Out can be viewed and set on the View pages. See “Viewing Channel Parameter Settings” on page 150 and “Viewing Channel Fader Settings” on page 151 for more information.

## Copying Stereo Out Settings

Settings can be copied between the left and right channels of the Stereo Out by using the Channel Copy function. See “Copying Channel Settings” on page 155 for more information.

## Naming the Stereo Out

The Stereo Out can be named for easy identification. See “Naming Channels” on page 156 for more information.

---

## 9 Bus Outs

---

### Patching Bus Outs to Outputs

Bus Outs can be patched to the Slot Outputs, Omni Outs, or the 2TR Digital Outputs. See “Output Patching” on page 79 for more information.

### Routing Input Channels to Bus Outs

Input Channels can be routed to the Bus Outs. See “Routing Input Channels” on page 93 for more information.

### Metering Bus Outs

Bus Out signal levels can be metered on the Meter pages. See “Metering” on page 127 for more information.

### Monitoring Bus Outs

Bus Outs can be assigned to the CONTROL ROOM [ASSIGN 1] or [ASSIGN 2] button for monitoring. See “Control Room Monitoring” on page 158 for more information.

### Attenuating Bus Outs

Bus Out signals can be attenuated pre-EQ. See “Attenuating Signals” on page 130 for more information.

### EQ'ing Bus Outs

Each Bus Out features 4-band parametric EQ. See “Using EQ” on page 131 for more information.

### Grouping Master EQs

Bus Out EQs can be grouped with the EQs of other Output Channels. See “Grouping Output Channel EQs” on page 135 for more information.

### Bus Out Inserts

Internal effects processors and external signal processors can be patched into the Bus Outs by using the Inserts. See “Using Inserts” on page 135 for more information.

### Compressing Bus Outs

Signal dynamics can be controlled by using the Bus Out Compressors. See “Compressing Channels” on page 137 for more information.

### Grouping Master Compressors

Bus Out Compressors can be grouped with the Compressors of other Output Channels. See “Grouping Output Channel Compressors” on page 140 for more information.

## Muting Bus Outs (ON/OFF)

Bus Outs can be muted by using the channel strip [ON] buttons.

- 1 Press the **LAYER [MASTER]** button to select the Master Layer.
- 2 Use channel strip **[ON]** buttons 1–8 to mute the Bus Outs.



The [ON] button indicators of Bus Outs that are on light up.

ON

## Grouping Master Mutes (ON/OFF)

Bus Out Mutes can be grouped with the Mutes of other Output Channels. See “Grouping Output Channel Mutes (ON/OFF)” on page 149 for more information.

## Setting Bus Out Levels

Bus Out levels can be set as follows.

- 1 Press the **LAYER [MASTER]** button to select the Master Layer.
- 2 Press the **FADER MODE [FADER]** button to select Fader mode.
- 3 Use faders 1–8 to set the Bus Out levels.

Refer to the legend on the right side of the faders when setting Bus Out levels.

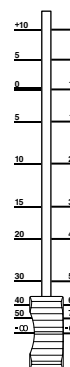

## Grouping Master Faders

Bus Out faders can be grouped with the faders of other Output Channels. See “Grouping Output Channel Faders” on page 146 for more information.

## Sending Bus Outs to Matrix Sends

Bus Out signals can be sent to the Matrix Sends. See “Matrix Sends” on page 121 for more information.

## Delaying Bus Outs

Each Bus Out features a Delay function. See “Delaying Channel Signals” on page 141 for more information.

## Inserting GEQs

Internal GEQs can be inserted into the Bus Outs. See “About the GEQs” on page 183 for more information.

## Soloing Bus Outs

Bus Outs can be soloed. See page 142 for more information.

## Pairing Bus Outs

Bus Outs can be paired for stereo operation. See “Pairing Channels” on page 144 for more information.

## Sending Bus Outs to the Stereo Out

Bus Outs can be routed to the Stereo Out buses as follows. Bus Out to Stereo Out settings can be stored in the Bus to Stereo library, which contains 1 preset memory and 32 user memories. See “Bus to Stereo Library” on page 169 for more information.

- 1 Use the SELECTED CHANNEL ROUTING [DISPLAY] button to locate the Bus to Stereo page.**

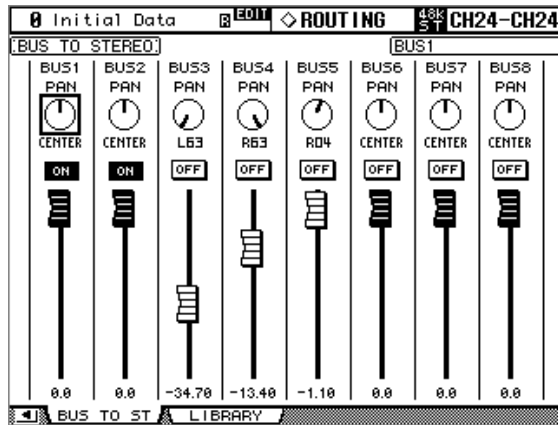

- 2 Use the cursor buttons to select the parameters, and use the Parameter wheel, INC/DEC buttons, and [ENTER] button to set them.**

**PAN:** These controls are used to pan the Bus Out signals between the left and right Stereo Out buses. The currently selected Pan control can be set to center by pressing [ENTER].

**ON/OFF:** These buttons are used to turn on and off the Bus Out to Stereo Out routing.

**Faders:** These faders are used to set the Bus Out to Stereo Out levels. Fader knobs appear highlighted when faders are set to 0.0 dB.

Press the [ENTER] button to set the currently-selected fader to 0.0 dB. You can copy the currently-selected fader position to other faders by double-clicking the [ENTER] button.

## Viewing Bus Out Settings

Parameter and fader settings for each Bus Out can be viewed and set on the View pages. See “Viewing Channel Parameter Settings” on page 150 and “Viewing Channel Fader Settings” on page 151 for more information.

## Copying Bus Out Settings

Bus Out settings can be copied to other Bus Outs by using the Channel Copy function. See “Copying Channel Settings” on page 155 for more information.

## Naming Bus Outs

Bus Outs can be named for easy identification. See “Naming Channels” on page 156 for more information.

# 10 Aux Sends

## Patching Aux Send Masters to Outputs

Aux Send Masters can be patched to the Slot Outputs, Omni Outs, or the 2TR Digital Outputs. See “Output Patching” on page 79 for more information.

## Setting the Aux Send Mode

Aux Sends have two operating modes—Variable and Fixed—which can be set individually for each of the 12 Aux Sends. In Variable mode, Aux Send levels are variable and the signal source point can be either pre-fader or post-fader. In Fixed mode, Aux Send levels are fixed at nominal and the signal source point is fixed to post-fader.

- 1 Use the **AUX SELECT [DISPLAY]** button to select the Aux Send pages.

The Aux Send parameters for the 96 Input Channels are divided among four pages. The Input Channel 1–24 Aux Send page is shown below: Variable mode on the left, Fixed mode on the right. The layout of the other three pages is the same.

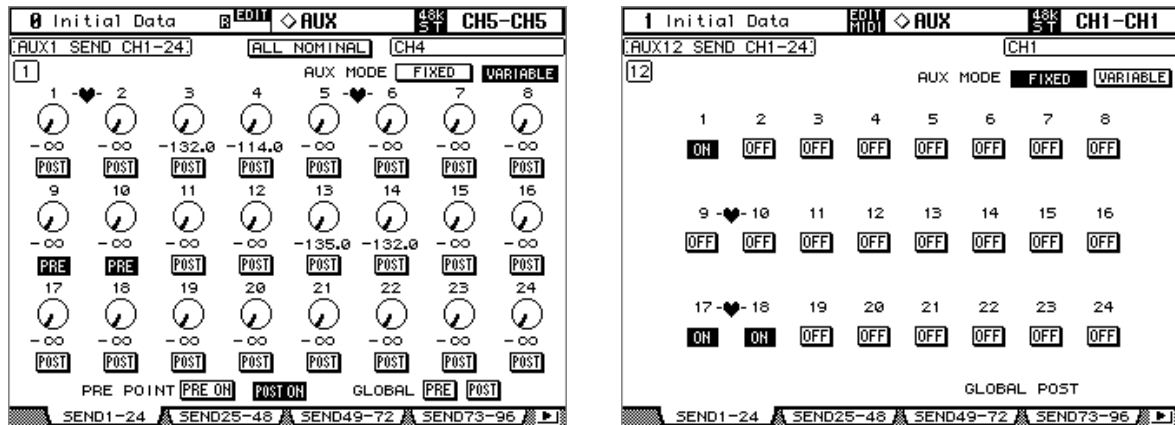

On the Fixed mode page, “GLOBAL POST” is displayed in the lower-right corner, indicating that the Aux Send Pre/Post parameter is fixed at Post.

- 2 Use the **AUX SELECT [AUX 1]–[AUX 12]** buttons to select Aux Sends 1–12.
- 3 Use the cursor buttons to select the **FIXED** and **VARIABLE** buttons, and press **[ENTER]** to select a mode.

When the Aux mode is changed, the parameters of the selected Aux Send are set as follows.

Parameters	Change from Variable to Fixed	Change from Fixed to Variable
Level	All set to nominal	All set to $-\infty$
Pre/Post	All set to Post	
On/Off	All turned off	All turned on

## Pre-Fader or Post-Fader Aux Sends

Aux Sends can be configured individually as either pre-fader or post-fader on the Aux Send pages (see page 112) or the Aux View pages (see page 115). If Aux Sends are configured as pre-fader, you can position the send points before or after the [ON] buttons.

## Setting Aux Send Levels

Aux Send levels can be set by using the SELECTED CHANNEL AUX/MATRIX SEND LEVEL controls, the faders, or the Encoders.

### Using the SELECTED CHANNEL AUX/MATRIX SEND LEVEL Controls

- 1 Use the LAYER buttons to select the Input Channel Layers, and use the [SEL] buttons to select Input Channels.
- 2 Use the [BANK] button to select Aux 1–4, Aux 5–8, or Aux 9–12.
- 3 Use the LEVEL controls to set the Aux Send levels.

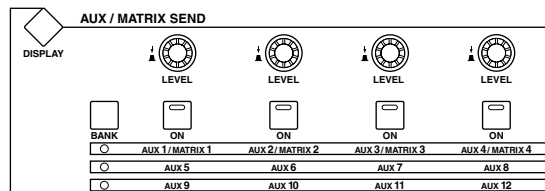

### Using the Faders

- 1 Use the LAYER buttons to select the Input Channel Layers.
- 2 Press the FADER MODE [AUX/MTRX] button to select the Aux/Mtrx Fader mode.
- 3 Use the AUX SELECT [AUX 1]–[AUX 12] buttons to select Aux Sends 1–12.
- 4 Use the faders to set the Aux Send levels.  
Refer to the legend on the left side of the faders when setting Aux Send levels.

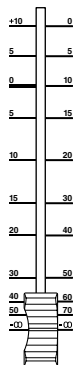

### Using the Encoders

- 1 Use the LAYER buttons to select the Input Channel Layers.
- 2 Press the ENCODER MODE [AUX/MTRX] button to select the Aux/Mtrx Encoder mode.
- 3 Use the AUX SELECT [AUX 1]–[AUX 12] buttons to select Aux Sends 1–12.
- 4 Use the Encoders to set the Aux Send levels.



## Muting Aux Sends (ON/OFF)

- 1 Use the LAYER buttons to select the Input Channel Layers, and use the [SEL] buttons to select the Input Channels.
- 2 Use the SELECTED CHANNEL AUX/MATRIX SEND [BANK] button to select Aux 1–4, Aux 5–8, or Aux 9–12.
- 3 Use the SELECTED CHANNEL AUX/MATRIX SEND [ON] buttons to turn the Aux Sends of the selected Input Channel on or off.

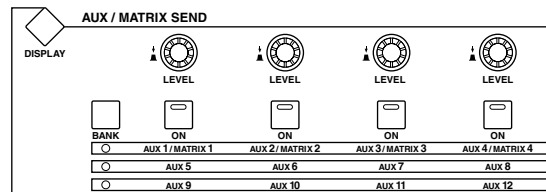

## Aux Send Pages

You can view and set the Aux Send parameters of all Input Channels on the Aux Send pages. Operation of the Aux Send pages in Variable and Fixed mode is explained separately.

### Variable Mode

See page 110 for information on how to select Variable Aux mode.

- 1 Use the AUX SELECT [DISPLAY] button to select the Aux Send pages.

The Aux Send parameters for the 96 Input Channels are divided among four pages. The Input Channel 1–24 Aux Send page in Variable mode is shown below. The layout of the other three pages is the same.

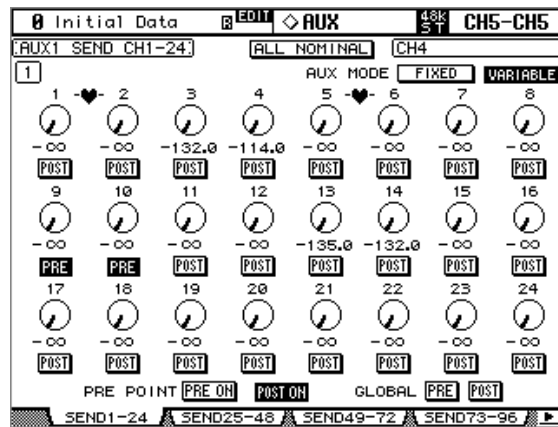

- 2 Use the AUX SELECT [AUX 1]–[AUX 12] buttons to select Aux Sends 1–12.
- 3 Use the cursor buttons to select the Input Channel Aux Send controls. Input Channels can also be selected by using the Input Channel Layer buttons and [SEL] buttons.
- 4 To turn Aux Sends on and off, select the rotary controls, and press [ENTER]. The rotary controls of Aux Sends that are turned off, appear gray, and “OFF” appears in place of the level value. Aux Send levels can still be changed even when Aux Sends are off.
- 5 To set Aux Send levels, select the rotary controls, and use the Parameter wheel or INC/DEC buttons.

To set Aux Send levels for all Input Channels to nominal, select the ALL NOMINAL button.



- 6 To set the Pre Fader and Post Fader parameters, select the PRE/POST buttons, then use the [ENTER] button or INC/DEC buttons.
- 7 To set all Input Channels for the selected Aux Send to pre-fader or post-fader simultaneously, select the GLOBAL PRE or POST button, and then press [ENTER].  
The PRE or POST button is highlighted, and remains highlighted as long as all Input Channel pre or post settings remain unchanged, so you can quickly see if all Input Channels are set to either pre-fader or post-fader.
- 8 If you selected pre-fader, turn on the PRE ON button or POST ON button to set the Pre point before or after each channel's [ON] button.

### Fixed Mode

See page 110 for information on how to select Fixed Aux mode.

- 1 Use the AUX SELECT [DISPLAY] button to select the Aux Send pages.

The Input Channel 1–24 Aux Send page in Fixed mode is shown below. The layout of the other three Aux Send pages in Fixed mode is the same.

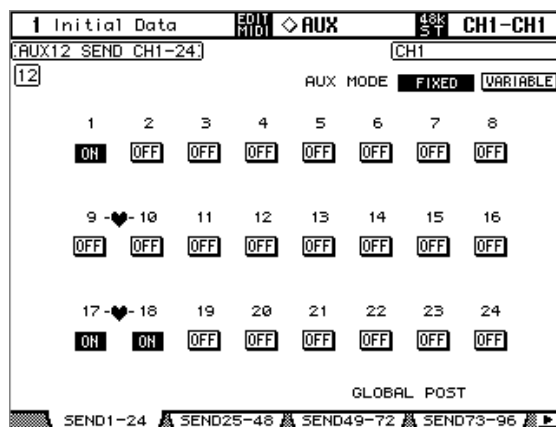

- 2 Use the AUX SELECT [AUX 1]–[AUX 12] buttons to select Aux Sends 1–12.
- 3 Use the cursor buttons or Parameter wheel to select the Aux Send buttons.  
Input Channels can also be selected by using the Input Channel Layer buttons and [SEL] buttons.
- 4 Use the [ENTER] button or INC/DEC buttons to turn Aux Sends on and off.  
If the Fader mode is set to Aux/Mtrx, the faders provide a visual indication of the On/Off status of each Input Channel for the currently selected Aux Send. For Aux Sends that are on, faders move to the nominal position. Aux Sends that are off, they move to the  $-\infty$  position. On/Off settings cannot be changed by using the faders.

## Viewing Aux Send Settings

You can view and set settings of all Aux Sends on the Aux View pages. Level and Pre/Post parameters are displayed separately. If the Auto AUX/MATRIX Display preference is on, and an Input Channel is currently selected, these pages appear automatically when a SELECTED CHANNEL AUX/MATRIX SEND control is operated. See “Auto AUX/MATRIX Display” on page 275 for more information.

### Level Parameters

In Level mode, the Aux View pages display Aux Send Level and On/Off parameters. Fixed mode Aux Sends can be turned on and off only.

- 1 Use the **AUX SELECT [DISPLAY]** button to select the Aux View pages.
- 2 Select the **DISPLAY LEVEL** button, and press **[ENTER]**.

The Aux View parameters for the 96 Input Channels are divided among four pages. The Input Channel 1–24 Aux View page is shown below in Level mode. The layout of the other three pages is the same.

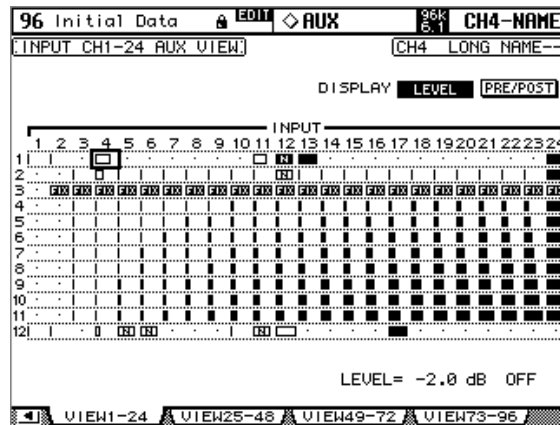

- 3 Use the cursor buttons to select the Input Channel Aux Sends. Input Channels can also be selected by using the Input Channel Layer buttons and **[SEL]** buttons. Aux Sends can also be selected by using the **AUX SELECT [AUX 1]–[AUX 12]** buttons.
- 4 Use the Parameter wheel or **INC/DEC** buttons to set the Aux Send levels.
- 5 Use the **[ENTER]** button to turn on and off the selected Aux Send.

The various Aux View page indicators are as follows:

- Send level set to  $-\infty$ , or Fixed mode Aux Send set to off.
- Send level bar.
- Send set to off.
- Send level set to nominal.
- Send off, level set to nominal.
- Fixed mode Aux Send set to on.

In Variable Aux mode, the Level and On/Off parameter values for the selected Aux Send are displayed in the lower-right corner of the page, for example, “LEVEL: -2.0 dB ON/OFF: ON.”

In Fixed Aux mode, the On/Off parameter values for the selected Aux Send are displayed in the lower-right corner of the page, for example, “LEVEL: FIXED ON/OFF: ON.”

## Pre/Post Parameters

In Pre/Post mode, the Aux View pages display Aux Send Pre/Post parameters. Fixed mode Aux Sends can be turned on and off only.

- 1 Use the **AUX SELECT [DISPLAY]** button to select the Aux View pages.
- 2 Select the **DISPLAY PRE/POST** button, and press **[ENTER]**.

The Input Channel 1–24 Aux View page is shown below in Pre/Post mode. The layout of the other three Aux View pages in Pre/Post mode is the same.

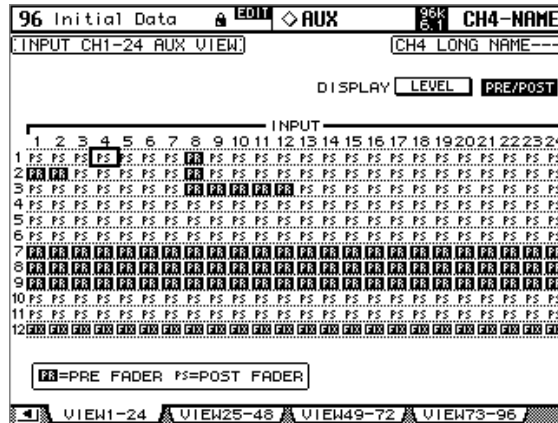

- 3 Use the cursor buttons or Parameter wheel to select the Input Channel Aux Sends.

Input Channels can also be selected by using the Input Channel Layer buttons and [SEL] buttons. Aux Sends can also be selected by using the AUX SELECT [AUX 1]–[AUX 12] buttons.

- 4 Use the **[ENTER]** button or INC/DEC buttons to set the selected Aux Send to either pre-fader or post-fader.

The various Aux View page indicators are as follows:

- PR** Aux Send configured pre-fader.
- PO** Aux Send configured post-fader.
- FX** Fixed mode Aux Send.

## Panning Aux Sends

When Aux Sends are paired, Aux Sends can be panned between the paired Aux buses. See “Pairing Channels” on page 144 for more information. If the selected Aux Send is not paired, the message “AUXx-x are not paired” appears.

If the currently selected pair of Aux Send Masters is set to Follow Surround on the Output Pair page, Aux Sends follow the Input Channel Surround Pan settings and cannot be set here, in which case the message “AUX x-x are Following Surround” appears. See “Pairing Aux Sends” on page 120 for more information.

### 1 Use the AUX SELECT [DISPLAY] button to select the Aux Pan pages.

The Aux Pan parameters for the 96 Input Channels are divided among four pages. The Input Channel 1–24 Aux Pan page is shown below. The layout of the other three pages is the same.

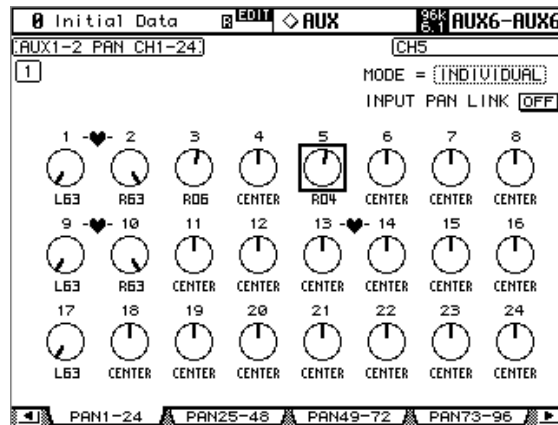

- 2 Use the AUX SELECT [AUX 1]–[AUX 12] buttons to select the Aux Sends 1–12.
- 3 Use the cursor buttons to select Input Channel Aux Send pan controls, and use the Parameter wheel or INC/DEC buttons to set them.

Input Channels can also be selected by using the Input Channel Layer buttons and [SEL] buttons.

The currently selected Pan control can be set to center by pressing [ENTER].

**MODE:** There are three Pan modes that determine how paired Aux Sends are panned: Individual, Gang, and Inverse Gang. This is an individual setting that applies to each send in a pair of Aux Sends.



In individual mode, Aux Send pan controls operate independently.

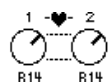

In Gang mode, the Aux Send pan controls of paired Input Channels operate in unison.



In Inverse Gang mode, the Aux Send pan controls of paired Input Channels operate in unison but move in opposite directions.

**INPUT PAN LINK:** This is used to link Aux Send Pan controls to Input Channel Pan controls so that operating an Input Channel Pan control also operates the corresponding Aux Send Pan control, and vice versa. This can be set individually for each pair of Aux Send Masters. When a link is established, the pan positions and Pan mode of the Input Channels are copied to the Aux Sends. While linked, the Pan mode can be set from either the Aux Pan page or the Input Channel Pan page (see page 96). The Pan mode setting for Aux Sends is linked to the Pan mode setting for Input Channels.

## Excluding Certain Channels from Aux Sends (Mix Minus)

You can quickly exclude certain channel signals from Aux Sends by using the controls on the top panel. This operation is called “Mix Minus.”

For example, when Aux Sends are being used as monitors for the musicians or a narrator, you can turn off the audio signals of the musicians or narrator, excluding them from the monitor sound.

- 1 **Press and hold down the AUX SELECT [AUX 1]–[AUX 12] buttons of the desired Aux Sends.**

The [ON] button indicators in the channel strip remain lit while you hold down the button. This means that signals routed from channels with a lit [ON] button indicator to the Aux Send are turned on.

*Note: If you release the AUX SELECT button before you proceed to Step 2, you will be unable to complete the Mix Minus operation.*

- 2 **Press the [ON] buttons of the Input Channels you wish to exclude from the Aux Send. You can select multiple channels.**

The selected channels’ [ON] button indicators turn off, and signals routed from those channels to the corresponding Aux Send are turned off. “MIX MINUS FOR AUX \*” appears at the bottom of the screen. (The asterisk represents an Aux number.)

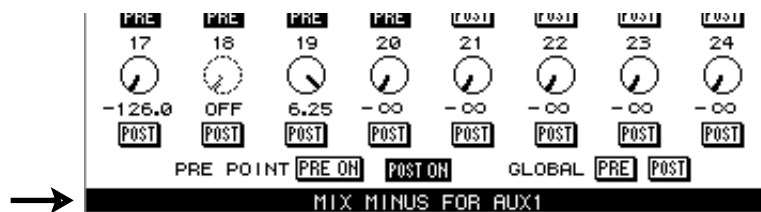

*Tip: At this time, the Send Level controls on the Aux Send page are grayed out.*

- 3 **To reset the setting, while pressing and holding down the AUX SELECT [AUX 1]–[AUX 12] buttons you pressed in Step 1, press the [ON] buttons you pressed in Step 2.**

The corresponding [ON] button indicators light up.

## Copying Channel Fader Positions to Aux Sends

While Aux Sends are in Variable mode, you can copy all Input Channel fader positions on one layer to the corresponding Aux Sends.

This is convenient when you wish to send to the musicians monitor signals that have the same balance setting as the Stereo Out signals.

- 1 **Locate the copy source layer button from the Input Channel Layer buttons, then press and hold down the button.**

*Note: If you release the button in the LAYER section before you proceed to Step 2, you will be unable to complete the Copy operation.*

- 2 **Press one of the AUX SELECT [AUX 1]–[AUX 12] buttons to select the desired Aux Send copy destination.**

The confirmation message appears.

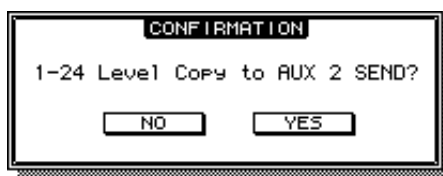

- 3 **To execute the Copy operation, move the cursor to the [YES] button, then press [ENTER].**

To cancel the Copy operation, move the cursor to the [NO] button, then press [ENTER].

*Tip: If the copy destination Input Channel has been paired with a vertical partner in another Layer, the fader position will be copied to the partner's Aux Send.*

## Metering Aux Send Masters

Aux Send Master levels can be metered on the Meter pages. See “Metering” on page 127 for more information.

## Monitoring Aux Send Masters

Aux Send Masters can be assigned to the CONTROL ROOM [ASSIGN 1] or [ASSIGN 2] button for monitoring. See “Control Room Monitoring” on page 158 for more information. Aux 11 and Aux 12 can be monitored via the STUDIO MONITOR OUT (see page 159).

## Attenuating Aux Send Masters

Aux Send Master signals can be attenuated pre-EQ. See “Attenuating Signals” on page 130 for more information.

## EQ'ing Aux Send Masters

Each Aux Send Master features 4-band parametric EQ. See “Using EQ” on page 131 for more information.

## Grouping Master EQs

Aux Send Master EQs can be grouped with the EQs of other Output Channels. See “Grouping Output Channel EQs” on page 135 for more information.

## Aux Send Master Inserts

Internal effects processors and external signal processors can be patched into the Aux Send Masters by using the Inserts. See “Using Inserts” on page 135 for more information.

## Compressing Aux Send Masters

Signal dynamics can be controlled by using the Aux Send Master Compressors. See “Compressing Channels” on page 137 for more information.

## Grouping Master Compressors

Aux Send Master Compressors can be grouped with the Compressors of other Output Channels. See “Grouping Output Channel Compressors” on page 140 for more information.

## Muting Aux Send Masters (ON/OFF)

Aux Send Masters can be muted as follows.

- 1 Press the **LAYER [MASTER]** button to select the Master Layer.
- 2 Use channel strip **[ON]** buttons 9–20 to mute the Aux Send Masters.



The [ON] button indicators of Aux Send Masters that are on light up.

ON

## Grouping Master Mutes (ON/OFF)

Aux Send Master Mutes can be grouped with the Mutes of other Output Channels. See “Grouping Output Channel Mutes (ON/OFF)” on page 149 for more information.

## Settings Aux Send Master Levels

Aux Send Master levels can be set as follows.

- 1 Press the **LAYER [MASTER]** button to select the Master Layer.
- 2 Press the **FADER MODE [FADER]** button to select the Fader mode.
- 3 Use faders 9–20 to set the Aux Send Master levels.

Refer to the legend on the right side of the faders when setting Aux Send Master levels.

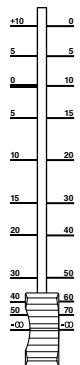

## Grouping Master Faders

Aux Send Master faders can be grouped with the faders of other Output Channels. See “Grouping Output Channel Faders” on page 146 for more information.

## Sending Aux Sends to Matrix Sends

Aux Send Master signals can be sent to the Matrix Sends. See “Matrix Sends” on page 121 for more information.

## Delaying Aux Send Masters

Each Aux Send Master features a Delay function. See “Delaying Channel Signals” on page 141 for more information.

## Inserting GEQs

Internal GEQs can be inserted into the Aux Send Masters. See “About the GEQs” on page 183 for more information.

## Soloing Aux Sends

Aux Sends can be soloed. See page 142 for more information.

## Pairing Aux Sends

Aux Sends can be paired for stereo operation. See “Pairing Channels” on page 144 for more information.

## Viewing Aux Send Master Settings

Parameter and fader settings for each Aux Send Master can be viewed and set on the View pages. See “Viewing Channel Parameter Settings” on page 150 and “Viewing Channel Fader Settings” on page 151 for more information.

## Copying Aux Send Master Settings

Aux Send Master settings can be copied to other Aux Sends by using the Channel Copy function. See “Copying Channel Settings” on page 155 for more information.

## Naming Aux Send Masters

Aux Send Masters can be named for easy identification. See “Naming Channels” on page 156 for more information.



# 11 Matrix Sends

## Patching Matrix Send Masters to Outputs

The left and right channels of the Matrix Send Masters can be patched to the Slot Outputs, Omni Outs, or the 2TR Digital Outputs. See “Output Patching” on page 79 for more information.

## Pre-Fader or Post-Fader Matrix Sends

Matrix Sends can be configured globally as either pre-fader or post-fader on the Matrix View page. See “Viewing Matrix Send Settings” on page 124 for more information.

## Setting Matrix Send Levels

Matrix Send levels can be set by using the SELECTED CHANNEL AUX/MATRIX SEND LEVEL controls, the faders, or the Encoders.

### Using the SELECTED CHANNEL AUX/MATRIX SEND LEVEL Controls

- 1 Use the LAYER [MASTER] button to select the Master Layer.
- 2 Use [SEL] buttons 1–20 to select the Bus Outs and Aux Sends, and use the STEREO [SEL] button to select the Stereo Out.

The Matrix Sends for the left and right channels of the Stereo Out can be set individually. Use the STEREO [SEL] button to select the left and right channels.

- 3 Use the LEVEL controls to set the Matrix Send levels.

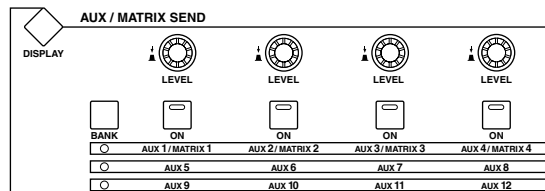

### Using the Faders

Stereo Out Matrix Sends cannot be set using the faders.

- 1 Use the LAYER [MASTER] button to select the Master Layer.
- 2 Press the FADER MODE [AUX/MTRX] button to select the Aux/Mtrx Fader mode.
- 3 Use the MATRIX SELECT [1–4] buttons to select Matrix Sends 1–4.
- 4 Use faders 1–20 to set the Matrix Send levels.

Faders 21–24 are inactive because Matrix Send Masters do not feature Matrix Send controls.

Refer to the legend on the left side of the faders when setting Matrix Send levels.

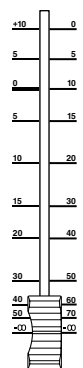

### Using the Encoders

Stereo Out Matrix Sends cannot be set using the Encoders.

- 1 Press the LAYER [MASTER] button to select the Master Layer.
- 2 Press the ENCODER MODE [AUX/MTRX] button to select the Aux/Mtrx Encoder mode.
- 3 Use the MATRIX SELECT [1–4] buttons to select Matrix Sends 1–4.
- 4 Use Encoders 1–20 to set the Matrix Send levels.

Encoders 21–24 are inactive because Matrix Send Masters do not feature Matrix Send controls.



### Muting Matrix Sends (ON/OFF)

- 1 Press the LAYER [MASTER] button to select the Master Layer.
- 2 Use [SEL] buttons 1–20 to select the Bus Outs and Aux Sends, and use the STEREO [SEL] button to select the Stereo Out.

The Matrix Sends for the left and right channels of the Stereo Out can be muted individually. Use the STEREO [SEL] button to select the left and right channels.

- 3 Use the SELECTED CHANNEL AUX/MATRIX SEND [ON] buttons to turn the Matrix Sends on the selected Output Channel on and off.

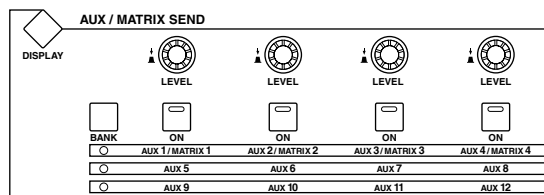

### Matrix Send Pages

Matrix Send parameters for the Bus Outs, Aux Sends, and the Stereo Out can be viewed and set on the Matrix Send page.

- 1 Use the MATRIX SELECT [DISPLAY] button to select the Matrix Send page.

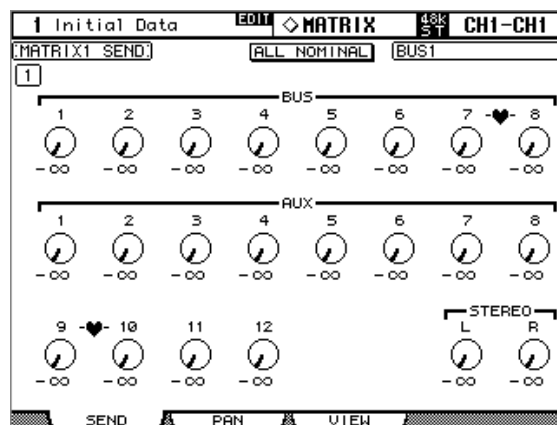

- 2 Use the Matrix SELECT [1–4] buttons to select Matrix Sends 1–4.
- 3 Use the cursor buttons to select the Output Channel Matrix Send controls. If the Master Layer is selected, [SEL] buttons 1–20 can also be used to select Output Channels.

- 4 To turn Matrix Sends on and off, select the rotary controls, and press [ENTER].

The rotary controls of Matrix Sends that are turned off, appear gray, and “OFF” appears in place of the level value. Matrix Send levels can still be changed even when Matrix Sends are off.

- 5 To set Matrix Send levels, select the rotary controls, and use the Parameter wheel or INC/DEC buttons.

**ALL NOMINAL:** This button resets the levels for all Matrix Sends to nominal.

## Panning Matrix Sends

Matrix Sends can be panned on the Matrix Send Pan page. The Matrix Sends for the left and right channels of the Stereo Out can be panned individually.

- 1 Use the MATRIX SELECT [DISPLAY] button to select the Matrix Send Pan page.

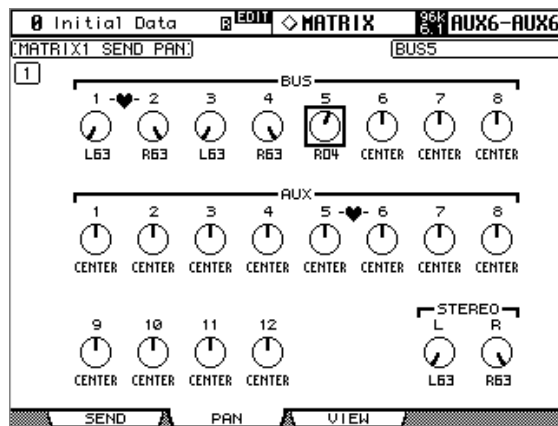

- 2 Use the MATRIX SELECT [1–4] buttons to select Matrix Sends 1–4.
- 3 Use the cursor buttons to select Output Channel Matrix Send pan controls, and use the Parameter wheel or INC/DEC buttons to set them.

If the Master Layer is currently selected, [SEL] buttons 1–20 can also be used to select Output Channels.

The currently selected Pan control can quickly be set to center by pressing [ENTER].

## Viewing Matrix Send Settings

You can view and set the Matrix Send Level and On/Off parameters of all Matrix Sends on the Matrix View page. If the Auto AUX/MATRIX Display preference is on, and a Bus Out, Aux Send, or the Stereo Out is currently selected, this page appears automatically when a SELECTED CHANNEL AUX/MATRIX SEND control is operated. See “Auto AUX/MATRIX Display” on page 275 for more information.

- 1 Use the **MATRIX SELECT [DISPLAY]** button to select the Matrix Send View page.

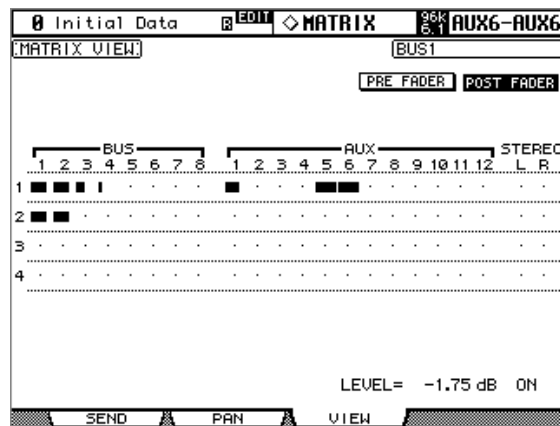

- 2 Use the cursor buttons to select the **PRE FADER** and **POST FADER** buttons, and press **[ENTER]** to set all Matrix Sends to either pre-fader or post-fader.
- 3 Use the cursor buttons to select the **Output Channel Matrix Sends**.  
If the Master Layer is currently selected, **[SEL]** buttons 1–20 can also be used to select Output Channels. Matrix Sends can also be selected by using the **MATRIX SELECT [1–4]** buttons.
- 4 Use the **Parameter wheel** or **INC/DEC** buttons to set the levels of the Matrix Sends.
- 5 Use the **[ENTER]** button to turn on and off the selected Matrix Send.

The various Matrix View page indicators are as follows:

- Send level set to  $-\infty$ .
- Send level bar.
- Send set to off.
- Send level set to nominal.
- Send off, level set to nominal.

The level in dB and the on/off values of the currently selected Matrix Send are displayed in the lower-right corner of the page.

## Metering Matrix Send Masters

Matrix Send Master levels can be metered on the Meter pages. See “Metering” on page 127 for more information.

## Monitoring Matrix Send Masters

Matrix Send Masters can be assigned to the **CONTROL ROOM [ASSIGN 1]** or **[ASSIGN 2]** button for monitoring. See “Control Room Monitoring” on page 158 for more information.

## Attenuating Matrix Send Masters

Matrix Send Master signals can be attenuated pre-EQ. See “Attenuating Signals” on page 130 for more information.

## EQ'ing Matrix Send Masters

Each Matrix Send Master features 4-band parametric EQ. See “Using EQ” on page 131 for more information.

## Grouping Master EQs

Matrix Send Master EQs can be grouped with the EQs of other Output Channels. See “Grouping Output Channel EQs” on page 135 for more information.

## Matrix Send Master Inserts

Internal effects processors and external signal processors can be patched into the Matrix Send Masters by using the Inserts. See “Using Inserts” on page 135 for more information.

## Compressing Matrix Send Masters

Signal dynamics can be controlled by using the Matrix Send Master Compressors. See “Compressing Channels” on page 137 for more information.

## Grouping Master Compressors

Matrix Send Master Compressors can be grouped with the Compressors of other Output Channels. See “Grouping Output Channel Compressors” on page 140 for more information.

## Muting Matrix Send Masters (ON/OFF)

Matrix Send Masters can be muted as follows.

- 1 Press the **LAYER [MASTER]** button to select the Master Layer.
- 2 Use channel strip **[ON]** buttons 21–24 to mute the Matrix Sends Masters.



The [ON] button indicators of Matrix Send Masters that are on light up.

## Grouping Master Mutes (ON/OFF)

Matrix Send Master Mutes can be grouped with the Mutes of other Output Channels. See “Grouping Output Channel Mutes (ON/OFF)” on page 149 for more information.

## Setting Matrix Send Master Levels

Matrix Send Master levels can be set as follows.

- 1 Press the **LAYER [MASTER]** button to select the Master Layer.
- 2 Press the **FADER MODE [FADER]** button to select the Fader mode.
- 3 Use faders 21–24 to set the Matrix Send Master levels.

Refer to the legend on the right side of the faders when setting Matrix Send Master levels.

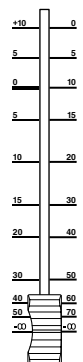

## Grouping Master Faders

Matrix Send Master faders can be grouped with the faders of other Output Channels. See “Grouping Output Channel Faders” on page 146 for more information.

## Balancing Matrix Send Masters

The left and right channels of the Matrix Send Masters can be balanced as follows.

- 1 **Press the LAYER [MASTER] button to select the Master Layer, and use [SEL] buttons 21–24 to select the Matrix Send Masters.**

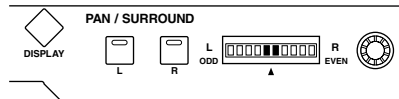

- 2 **Use the Pan control to set the balance of the currently selected Matrix Send Master.**

The pan display indicates the balance. When the balance is set to center, the center two segments light up. Balance can be set to center by pressing [ENTER].

Matrix Send Master balance can also be set on the Matrix Fader View pages. See “Viewing Channel Fader Settings” on page 151 for more information.

## Delaying Matrix Send Masters

Each Matrix Send Master features a Delay function. See “Delaying Channel Signals” on page 141 for more information.

## Soloing Matrix Sends

Matrix Sends can be soloed. See page 142 for more information.

## Inserting GEQs

Internal GEQs can be inserted into the left and right channels of the Matrix Send Masters. See “About the GEQs” on page 183 for more information.

## Viewing Matrix Send Master Settings

Parameter and fader settings for each Matrix Send Master can be viewed and set on the View pages. See “Viewing Channel Parameter Settings” on page 150 and “Viewing Channel Fader Settings” on page 151 for more information.

## Copying Matrix Send Master Settings

Matrix Send Master settings can be copied to other Matrix Sends by using the Channel Copy function. See “Copying Channel Settings” on page 155 for more information.

## Naming Matrix Send Masters

Matrix Send Masters can be named for easy identification. See “Naming Channels” on page 156 for more information.

# 12 Common Channel Functions

## Metering

Input Channels, Bus Outs, Aux Sends, Matrix Sends, the Stereo Out, and the Effects processors can be metered on the various Meter pages, which are located by using the DISPLAY ACCESS [METER] button.

Input and Output Channel Meter pages also display fader positions numerically. The Peak Hold function, which applies to all level meters, can be turned on or off on any of the Meter pages.

## Setting the Metering Position

Input and Output Channels can be metered pre-EQ, pre-fader, or post-fader. This setting, which can be set independently for the Input and Output Channels, can be set on the Metering Position page shown below, or any of the Input and Output Channel Meter pages.

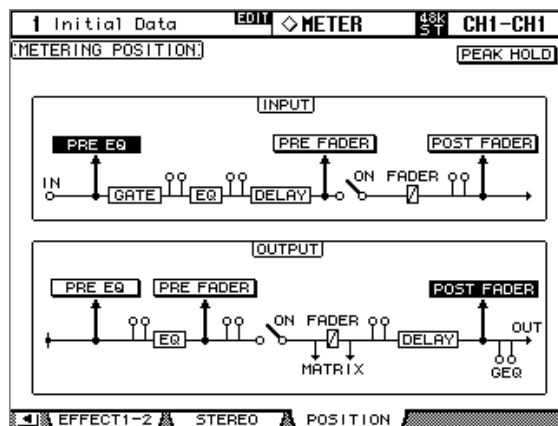

**PRE EQ:** Channels are metered pre-EQ.

**PRE FADER:** Channels are metered pre-fader.

**POST FADER:** Channels are metered post-fader.

### Metering Input Channels

There are two types of Input Channel Meter page: 24-channel and 48-channel.

There are four 24-channel Meter pages. The Input Channel 1–24 Meter page is shown below. The layout of the other three pages is the same. These pages feature two level meters for each Input Channel. When Input Channels are vertically paired, both meters operate. When Input Channels are horizontally paired, only the left-hand meter operates.

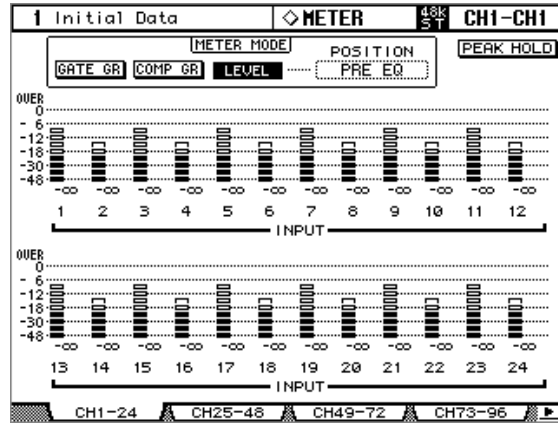

**GATE GR:** The meters indicate the gain reduction being applied by the Gate.

**COMP GR:** The meters indicate the gain reduction being applied by the Compressor.

There are two 48-channel Meter pages. The Input Channel 1–48 Meter page is shown below. The layout of the other page is the same.

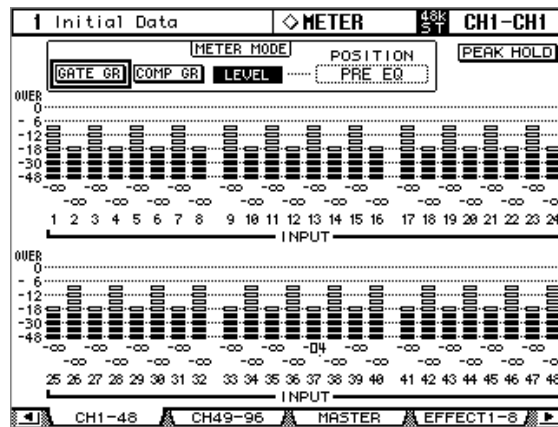



## Metering Output Channels

Bus Outs, Aux Sends, Matrix Sends, and the Stereo Out can all be metered on the Master Meter page.

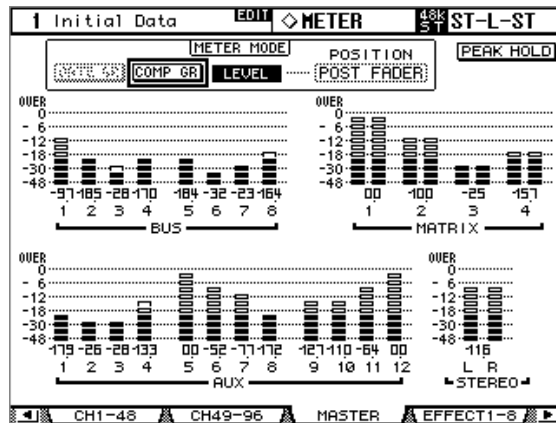

## Metering Effects

There are two Effects Input/Output Meter pages: Effects 1–8 and Effects 1–2.

The Effects 1–8 Input/Output Meter page features two input and output level meters for each of the internal effects processors.

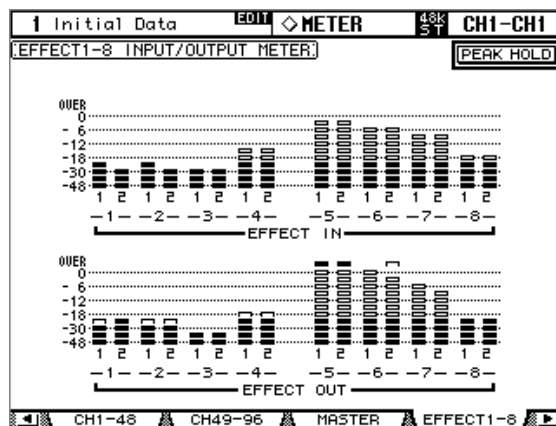

The Effects 1–2 Input/Output Meter page features individual level meters for the eight inputs and outputs of internal effects processors #1 and #2.

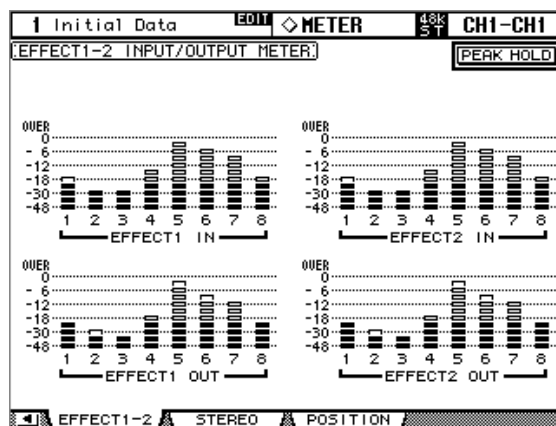

### Metering the Stereo out

The Stereo Out can be metered on the Stereo Meter page. Peak signal levels for the left and right channels are displayed numerically.

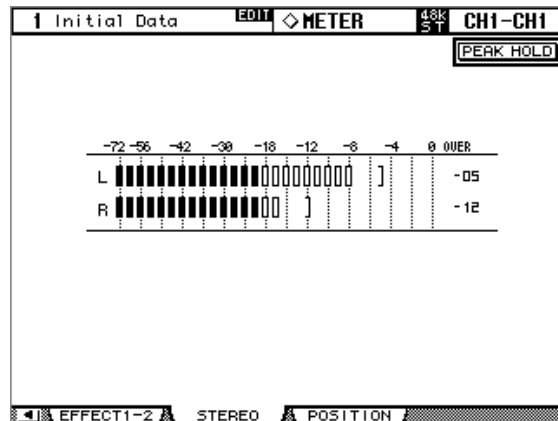

### Attenuating Signals

Input Channels, Bus Outs, Aux Sends, Matrix Sends, and the Stereo Out all feature pre-EQ attenuation, which is useful for attenuating “hot” signals before EQ’ing.

#### Using the SELECTED CHANNEL EQUALIZER ATT Control

- 1 Use the LAYER buttons to select Layers, and use the [SEL] buttons to select channels.
- 2 Use the ATT control to set the amount of attenuation.



#### Attenuator Pages

Attenuator settings can be viewed and set on the Attenuator pages.

- 1 Use the EQUALIZER [DISPLAY] button to select the Attenuator pages.

The Attenuator parameters for the 96 Input Channels are arranged into four pages. The Input Channel 1–24 Attenuator/Shifter page is shown below. The layout of the other three pages is the same.

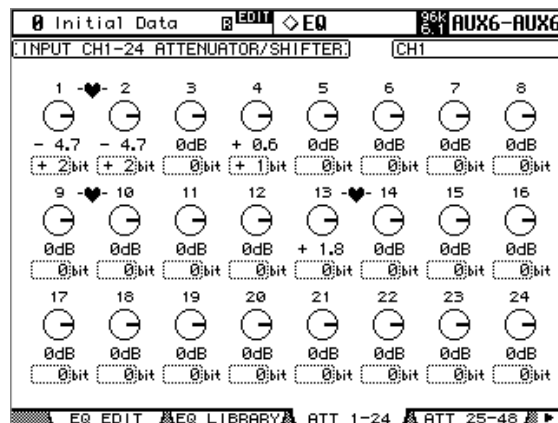

The attenuator parameters for the Output Channels appear on the Output Attenuator page.

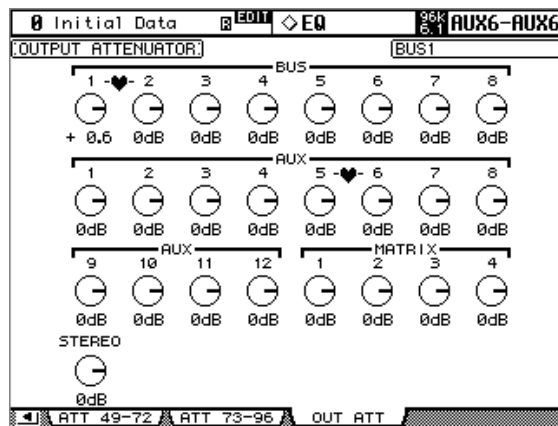

- 2 Use the cursor buttons to select the channels, and use the Parameter wheel or INC/DEC buttons to set the amount of attenuation.

Input and Output Channels can also be selected by using the LAYER and [SEL] buttons.

You can copy the currently selected Input or Output Channel attenuation setting to all Input or Output Channels respectively by double-clicking the [ENTER] button.

For Input Channels, you can also set the amount of attenuation in bits from +2 bits to –24 bits. Use the cursor buttons to select the bit shift parameters, then use the Parameter wheel or INC/DEC buttons to set them. The rotary attenuators and the bit shift parameters can be set independently.

You can set the attenuator parameters for individual Input and Output Channels on the Input Attenuator and Output Attenuator pages, regardless of paired channels. The changes made on the Attenuator pages, along with the level balance between channels, will be reflected in the settings in the SELECTED CHANNEL section, in the EQUALIZER [ATT] controls, and on the EQ Edit page.

## Using EQ

Input Channels, Bus Outs, Aux Sends, Matrix Sends, and the Stereo Out all feature 4-band parametric EQ. The LOW-MID and HIGH-MID bands are peaking type. The LOW and HIGH bands can be set to shelving, peaking, or HPF and LPF respectively. EQ settings can be stored in the EQ library, which contains 40 preset memories and 160 user memories. See “EQ Library” on page 172 for more information.

## Preset EQs

The following table lists the preset EQs. See page 332 for detailed parameter information.

#	Preset Name	Description
1	<b>Bass Drum 1</b>	Emphasizes the low range of a bass drum and the attack created by the beater.
2	<b>Bass Drum 2</b>	Creates a peak around 80 Hz, producing a tight, stiff sound.
3	<b>Snare Drum 1</b>	Emphasizes “snappy” and rimshot sounds.
4	<b>Snare Drum 2</b>	Emphasizes various ranges for that classic rock snare drum sound.
5	<b>Tom-tom 1</b>	Emphasizes the attack of tom-toms, and creates a long, “leathery” decay.
6	<b>Cymbal</b>	Emphasizes the attack of crash cymbals, extending the “sparkling” decay.
7	<b>High Hat</b>	Use on a tight high-hat, emphasizing the mid to high range.
8	<b>Percussion</b>	Emphasizes attack and adds clarity to the high-range of instruments, such as shakers, cabasas, and congas.
9	<b>E. Bass 1</b>	Produces a tight electric bass sound by cutting very low frequencies.
10	<b>E. Bass 2</b>	Unlike preset 9, this preset emphasizes the low range of an electric bass.
11	<b>Syn. Bass 1</b>	Use on a synth bass with emphasized low range.
12	<b>Syn. Bass 2</b>	Emphasizes the attack that is peculiar to synth bass.
13	<b>Piano 1</b>	Makes pianos sound brighter.
14	<b>Piano 2</b>	Used in conjunction with a compressor, this preset emphasizes the attack and low range of pianos.
15	<b>E. G. Clean</b>	Use for line-level recording of an electric or semi-acoustic guitar to get a slightly harder sound.
16	<b>E. G. Crunch 1</b>	Adjusts the tonal quality of a slightly distorted guitar sound.
17	<b>E. G. Crunch 2</b>	A variation on preset 16.
18	<b>E. G. Dist. 1</b>	Makes a heavily distorted guitar sound clearer.
19	<b>E. G. Dist. 2</b>	A variation on preset 18.
20	<b>A. G. Stroke 1</b>	Emphasizes the bright tones of acoustic guitars.
21	<b>A. G. Stroke 2</b>	A variation on preset 20. You can also use it with gutsy guitar sounds.
22	<b>A. G. Arpeg. 1</b>	Ideal for arpeggio playing on acoustic guitars.
23	<b>A. G. Arpeg. 2</b>	A variation on preset 22.
24	<b>Brass Sec.</b>	Use with trumpets, trombones, or saxes. When used with a single instrument, try adjusting the HIGH or HIGH-MID frequency.
25	<b>Male Vocal 1</b>	An EQ template for male vocals. Try adjusting the HIGH or HIGH-MID parameters according to the voice quality.
26	<b>Male Vocal 2</b>	A variation on preset 25.
27	<b>Female Vo. 1</b>	An EQ template for female vocals. Try adjusting the HIGH or HIGH-MID parameters according to the voice quality.
28	<b>Female Vo. 2</b>	A variation on preset 27.
29	<b>Chorus&amp;Harmo</b>	An EQ template for brightening choruses.
30	<b>Total EQ 1</b>	Use on a stereo mix during mixdown. Sounds even better when used with a compressor.
31	<b>Total EQ 2</b>	A variation on preset 30.
32	<b>Total EQ 3</b>	A variation on preset 30. Can also be used with paired Input or Output Channels.
33	<b>Bass Drum 3</b>	A variation on preset 1, with low and mid range reduced.
34	<b>Snare Drum 3</b>	A variation on preset 3, creating a thicker sound.
35	<b>Tom-tom 2</b>	A variation on preset 5, emphasizing the mid and high ranges.
36	<b>Piano 3</b>	A variation on preset 13.
37	<b>Piano Low</b>	Emphasizes the low range of pianos recorded in stereo.
38	<b>Piano High</b>	Emphasizes the high range of pianos recorded in stereo.
39	<b>Fine-EQ Cass</b>	Add clarity when recording to or from cassette tape.
40	<b>Narrator</b>	Ideal for recording narration.

## Using the SELECTED CHANNEL EQUALIZER Controls

- 1 Use the **LAYER** buttons to select Layers, and use the **[SEL]** buttons to select channels.

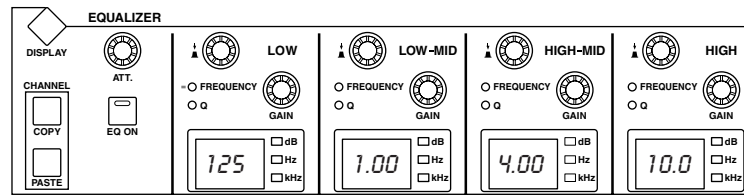

- 2 Use the **[EQ ON]** button to turn the EQ on or off.
- 3 Use the **GAIN** controls to set the gain of each band.  
When a GAIN control is adjusted, the gain in dB is displayed on the corresponding EQ display. If the GAIN control is not adjusted for two seconds, the EQ display returns to displaying the frequency.
- 4 To set the frequency, press a **FREQUENCY/Q** control so that the **FREQUENCY** indicator lights up, and use the **FREQUENCY/Q** control to set the frequency.  
The frequency is displayed by the corresponding EQ display.
- 5 To set the **Q**, press a **FREQUENCY/Q** control so that the **Q** indicator lights up, and use the **FREQUENCY/Q** control to set the **Q**.

The Q value is displayed by the corresponding EQ display. If the Q control is not adjusted for two seconds, the EQ display returns to displaying the frequency.

To reset an individual gain control, hold down the corresponding **FREQUENCY/Q** control. To reset all gain controls, press the **LOW** and **HIGH** **FREQUENCY/Q** controls.

The EQ parameter ranges are as follows.

Parameter	LOW	LOW-MID	HIGH-MID	HIGH
Gain	-18.0 dB to +18.0 dB (0.1 dB steps) <sup>1</sup>			
Frequency	21.2 Hz to 20.0 kHz (120 steps per 1/12 octave)			
Q	HPF, 10.0 to 0.10 (41 steps), L.SHELF	10.0 to 0.10 (41 steps)		LPF, 10.0 to 0.10 (41 steps), H.SHELF

1. The **LOW** and **HIGH** **GAIN** controls function as filter on/off controls when **Q** is set to **HPF** or **LPF** respectively.

The initial EQ parameter settings are as follows.

Parameter	LOW	LOW-MID	HIGH-MID	HIGH
Gain	0 dB			
Frequency	125 Hz	1.00 kHz	4.00 kHz	10.0 kHz
Q	L.SHELF	0.70		H.SHELF

## EQ Edit Pages

EQ parameters can also be set on the EQ Edit page. If the Auto EQUALIZER Display preference is on, this page appears automatically when a control in the SELECTED CHANNEL EQUALIZER section is operated. See “Auto EQUALIZER Display” on page 275.

- 1 Use the EQUALIZER [DISPLAY] button to select the EQ Edit page.

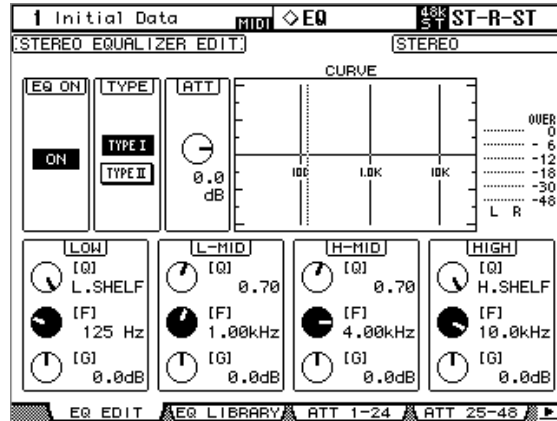

- 2 Use the LAYER buttons to select Layers, and use the [SEL] buttons to select channels.
- 3 Use the cursor buttons to select the parameters, and use the Parameter wheel and INC/DEC buttons to set them.

**EQ ON:** This turns the EQ on and off. The [ENTER] button can be used to turn this on and off so long as any parameter other than TYPE is selected.

**TYPE:** This selects the type of EQ: TYPE I (the EQ type used on legacy Yamaha digital mixing consoles) or TYPE II (a newly developed algorithm).

**ATT:** This can be used to attenuate signals pre-EQ. It's the same Attenuator parameter that appears on the Attenuator pages. See “Attenuating Signals” on page 130 for more information.

**CURVE:** This displays the EQ curve of the currently selected Input Channel.

**Level meters:** These meters indicate the levels of the currently selected Input Channel and its horizontal or vertical partner.

**LOW, L-MID, H-MID, HIGH:** These are the Q, Frequency (F), and Gain (G) parameters for the four bands. The parameter (F or Q) you selected using the FREQUENCY/Q control is highlighted.

## Grouping Output Channel EQs

The Bus Out, Aux Send, Matrix Send, and Stereo Out EQs can be grouped, allowing you to control the EQ of several Output Channels simultaneously. There are four Output Channel EQ groups: e, f, g, and h.

- 1 Use the **DISPLAY ACCESS [GROUP]** button to locate the **Output Equalizer Link** page.

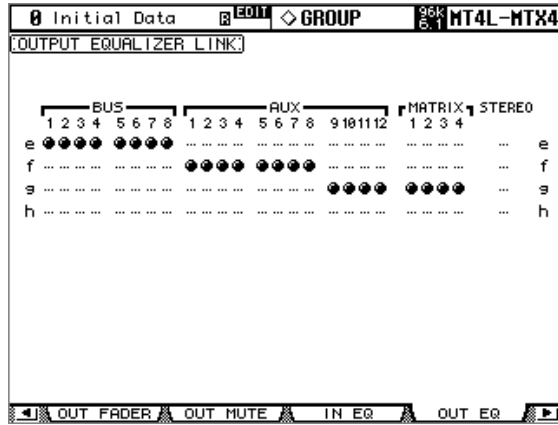

- 2 Press the **LAYER [MASTER]** button.
- 3 Use the **Up/Down** cursor buttons to select EQ groups e–h.  
The selected group is highlighted by a flashing cursor box.
- 4 Use the **[SEL]** buttons to add and remove Output Channels to and from the selected group.  
The EQ settings of the first Output Channel added to the group are applied to all subsequently added Output Channels.  
When an Output Channel is added to a group, its **[SEL]** button indicator lights up.

## Using Inserts

Input Channels, Bus Outs, Aux Sends, Matrix Sends, and the Stereo Out all feature assignable Inserts.

### Using the **SELECTED CHANNEL PHASE/INSERT [INSERT ON]** Button

- 1 Use the **LAYER** buttons to select Layers, and use the **[SEL]** buttons to select channels.
- 2 Use the **[INSERT ON]** button to turn the currently selected channel's Insert on or off.



### Insert Pages

Inserts can be configured on the Insert page. If the Auto PHASE/INSERT Display preference is on, this page appears automatically when you press the SELECTED CHANNEL PHASE/INSERT [INSERT ON] button, turning on the button indicator. See “Auto PHASE/INSERT Display” on page 274.

- 1 Use the SELECTED CHANNEL PHASE/INSERT [DISPLAY] button to select the Insert page.

The Insert page for the Input Channels is shown on the left; the Insert page for the Bus Outs, Aux Sends, and the Stereo out, on the right.

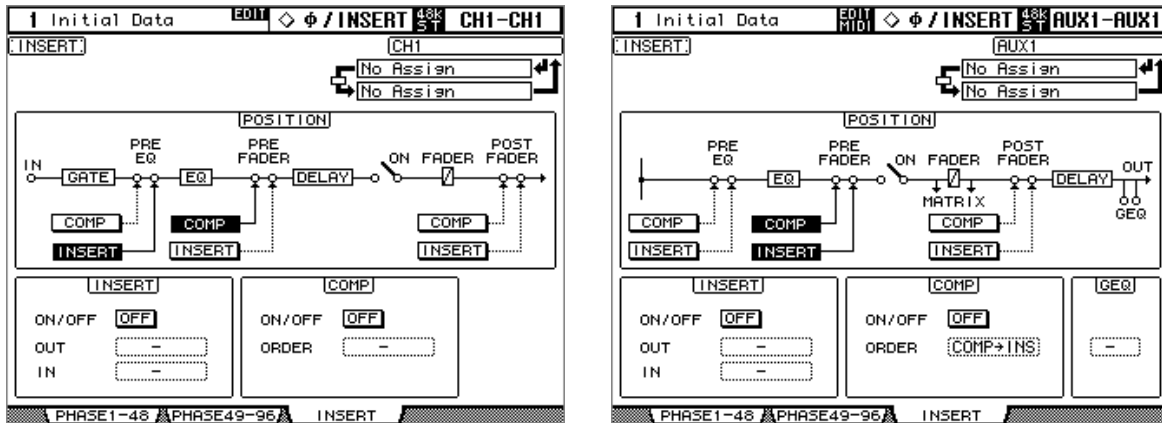

The Insert page for the Matrix Sends is shown below.

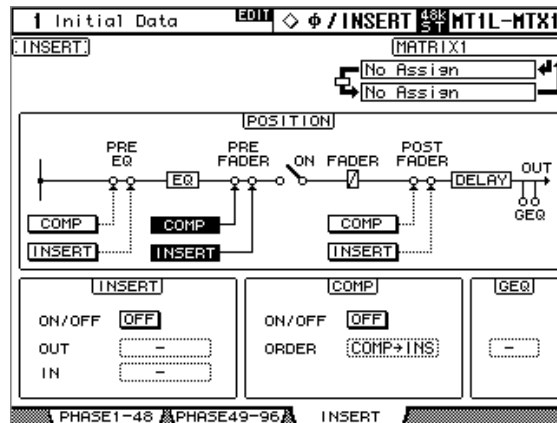

- 2 Use the LAYER buttons to select Layers, and use the [SEL] buttons to select channels.
- 3 Use the cursor buttons to select the parameters, and use the Parameter wheel, INC/DEC buttons, and [ENTER] button to set them.

**POSITION:** This determines the position of the Insert and Compressor within the channel, and can be set to pre-EQ, pre-fader, or post-fader. Click the desired [COMP] and [INSERT] buttons in the POSITION block diagram to select the Compressor and Insert positions.

**INSERT ON/OFF:** This turns the currently selected channel’s Insert on and off. It works in unison with the SELECTED CHANNEL PHASE/INSERT [INSERT ON] button.

**INSERT OUT:** This selects the destination for the Insert Out, which can be a Slot Output, Omni Out, 2TR Digital Output, or the input to an internal effects processor. See page 286 and page 290 for Input and Output patch parameter lists. The Port ID of the currently selected destination is displayed below the currently selected channel’s Long name in the upper-right corner of the page. The destination port can also be selected by using the Patch



Select window (see page 83), which is accessed by pressing [ENTER] while this parameter is selected. Insert Outs can also be patched on the Output Patch pages. See “Output Patching” on page 79 for more information.

**INSERT IN:** This selects the source for the Insert In, which can be an AD Input, Slot Input, 2TR Digital or Analog Input, or the output of an internal effects processor. See page 286 for a list of Input Channel Insert In sources; page 290 for a list of Output Channel Insert In sources. The Port ID of the currently selected source is displayed below the currently selected channel’s Long name in the upper-right corner of the page. The source port can also be selected by using the Patch Select window (see page 83), which is accessed by pressing [ENTER] while this parameter is selected. Insert Ins can also be patched on the Input Channel Insert In Patch pages. See “Patching Input Channel Insert Ins” on page 78 for more information.

**COMP ON/OFF:** This turns the currently selected channel’s Compressor on and off. It works in unison with the SELECTED CHANNEL DYNAMICS [COMP ON] button, and the ON/OFF button on the Comp Edit page. See “Compressing Channels” on page 137 for more information.

**COMP ORDER:** If the Insert and Compressor are set to the same position in the channel (i.e., INSERT POSITION and COMP POSITION are the same), you can use this parameter to set the order of the Insert and Compressor to either Comp->Ins or Ins->Comp.

**GEQ:** This parameter allows you to insert a GEQ into the output of the currently selected Output Channel. This parameter can also be set on the Graphic Equalizer Edit page (see page 183) and the Graphic Equalizer Insert page (see page 82).

When a Y56K card effect, or an internal effects processor is inserted in the currently selected channel, when the EFFECTS/PLUG-INS [CHANNEL INSERTS] button is pressed, the corresponding EFFECTS/PLUG-INS [1–8] button indicator flashes, and the corresponding Effects, or Plug-In edit page appears. If it’s a Y56K card that’s inserted, the [PLUG-INS] button indicator also flashes. If it’s an internal effects processor, the [INTERNAL EFFECTS] button indicator also flashes. This applies only to effects that are inserted into channels. If there’s nothing inserted in the currently selected channel, a message appears.

## Compressing Channels

Input Channels, Bus Outs, Aux Sends, Matrix Sends, and the Stereo Out all feature a Compressor. Settings can be stored in the Comp library, which contains 36 preset memories and 92 user memories. See “Comp Library” on page 171 for more information.

### Preset Comps & Types

The following table lists the preset Comps and types. See page 334 for detailed parameter information.

#	Preset Name	Type	Description
1	Comp	COMP	Compressor intended to reduce the overall volume level. Use it on the stereo output during mixdown, or with paired Input or Output Channels.
2	Expand	EXPAND	Expander template.
3	Compannder (H)	COMPAND-H	Hard-kneed compressor template.
4	Compannder (S)	COMPAND-S	Soft-kneed compressor template.
5	A. Dr. BD	COMP	Compressor for use with acoustic bass drum.
6	A. Dr. BD	COMPAND-H	Hard-kneed compander for use with acoustic bass drum.
7	A. Dr. SN	COMP	Compressor for use with acoustic snare drum.
8	A. Dr. SN	EXPAND	Expander for use with acoustic snare drum.
9	A. Dr. SN	COMPAND-S	Soft-kneed compander for use with acoustic snare drum.
10	A. Dr. Tom	EXPAND	Expander for use with acoustic tom toms, which automatically reduces the volume when the tom toms are not played, improving mic separation.

#	Preset Name	Type	Description
11	<b>A. Dr. OverTop</b>	COMPAND-S	Soft-kneed compander for emphasizing the attack and ambience of cymbals recorded with overhead mics. It automatically reduces the volume when the cymbals are not played, improving mic separation.
12	<b>E. B. Finger</b>	COMP	Compressor for leveling the attack and volume of a finger-picked electric bass guitar.
13	<b>E. B. Slap</b>	COMP	Compressor for leveling the attack and volume of a slapped electric bass guitar.
14	<b>Syn. Bass</b>	COMP	Compressor for controlling or emphasizing the level of a synth bass.
15	<b>Piano1</b>	COMP	Compressor for brightening the tonal color of a piano.
16	<b>Piano2</b>	COMP	A variation on preset 15, using a deep threshold to change the overall attack and level.
17	<b>E. Guitar</b>	COMP	Compressor for electric guitar “cutting” or arpeggio-style backing. The sound color can be varied by playing different styles.
18	<b>A. Guitar</b>	COMP	Compressor for acoustic guitar “stroke” or arpeggio-style backing.
19	<b>Strings1</b>	COMP	Compressor for use with strings.
20	<b>Strings2</b>	COMP	A variation on preset 19, intended for violas or cellos.
21	<b>Strings3</b>	COMP	A variation on preset 20, intended for string instruments with a very low range, such as cellos or contrabass.
22	<b>BrassSection</b>	COMP	Compressor for brass sounds with a fast and strong attack.
23	<b>Syn. Pad</b>	COMP	Compressor for synth pad, intended to prevent diffusion of the sound.
24	<b>SamplingPerc</b>	COMPAND-S	Compressor for making sampled percussion sound like real acoustic percussion.
25	<b>Sampling BD</b>	COMP	A variation on preset 24, intended for sampled bass drum sounds.
26	<b>Sampling SN</b>	COMP	A variation on preset 25, intended for sampled snare drum sounds.
27	<b>Hip Comp</b>	COMPAND-S	A variation on preset 26, intended for sampled loops and phrases.
28	<b>Solo Vocal1</b>	COMP	Compressor for use with main vocals.
29	<b>Solo Vocal2</b>	COMP	A variation on preset 28.
30	<b>Chorus</b>	COMP	A variation on preset 28, intended for choruses.
31	<b>Click Erase</b>	EXPAND	Expander for removing a click track that may bleed through from a musician's headphones.
32	<b>Announcer</b>	COMPAND-H	Hard-kneed compander for reducing the level of the music when an announcer speaks.
33	<b>Limiter1</b>	COMPAND-S	A soft-kneed compander with a slow release.
34	<b>Limiter2</b>	COMP	A “peak-stop” compressor.
35	<b>Total Comp1</b>	COMP	Compressor for reducing the overall volume level. Use it on the stereo output during mixdown, or with paired Input or Output Channels.
36	<b>Total Comp2</b>	COMP	A variation on preset 35, but with more compression.

### Using the SELECTED CHANNEL DYNAMICS Controls

- 1 Use the LAYER buttons to select Layers, and use the [SEL] buttons to select channels.
- 2 Use the SELECTED CHANNEL DYNAMICS [COMP ON] button to turn the currently selected channel's Compressor on or off.

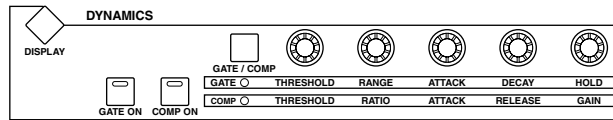

- 3 Use the SELECTED CHANNEL DYNAMICS [GATE/COMP] button to set the DYNAMICS controls to COMP (COMP indicator lit), and use the THRESHOLD, RATIO, ATTACK, RELEASE, and GAIN controls to set the Compressor. While an output Channel is selected, the [GATE/COMP] button is fixed at COMP.

### Comp Edit Page

Compressor settings can be viewed and set on the Comp Edit page. If the Auto DYNAMICS Display preference is on, this page appears automatically when a Compressor control in the SELECTED CHANNEL DYNAMICS section is operated. See “Auto DYNAMICS Display” on page 275.

- 1 Use the LAYER buttons to select Layers, and use the [SEL] buttons to select channels.
- 2 Use the SELECTED CHANNEL DYNAMICS [DISPLAY] button to locate the Comp Library page, and recall a preset Compressor that contains the comp type that you want. See “Comp Library” on page 171 for more information.
- 3 Use the SELECTED CHANNEL DYNAMICS [DISPLAY] button to locate the Comp Edit page.

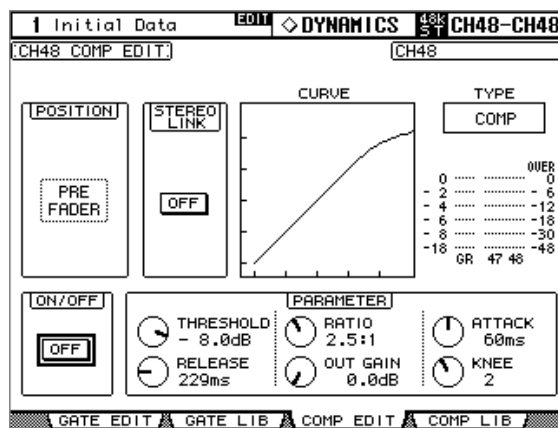

- 4 Use the cursor buttons to select the parameters, and use the Parameter wheel, INC/DEC buttons, and [ENTER] button to set them.
 

**POSITION:** This determines the position of the Compressor within the channel, and can be set to pre-EQ, pre-fader, or post-fader. It works in unison with the COMP POSITION parameter on the Insert page. See “Using Inserts” on page 135 for more information.

**STEREO LINK:** This allows you to pair Comps for stereo operation even when channels are not paired. Input Channel Comps are paired either horizontally or vertically depending on the Pair mode setting for the currently selected Input Channel. See “Pairing Channels” on page 144 for more information on horizontal and vertical pairing. When channels are paired, this parameter is turned on automatically and cannot be changed.

**CURVE:** This displays the Compressor curve (i.e., input level vs. output level).

**TYPE:** This is the comp type used by the currently selected channel's Compressor.

**Meters:** These meters indicate the levels of the currently selected Input Channel and its horizontal or vertical partner. The GR meter indicates the amount of gain reduction being applied by the currently selected channel's Compressor.

**ON/OFF:** This turns the currently selected channel's Compressor on and off. It works in unison with the SELECTED CHANNEL DYNAMICS [COMP ON] button.

**PARAMETER:** These controls are used to set the Threshold, Ratio, Attack, Release, Out Gain, and Knee (Width) parameters.

## Grouping Output Channel Compressors

The Bus Out, Aux Send, Matrix Send, and Stereo Out Compressors can be grouped, allowing you to control the compression of several Output Channels simultaneously. There are four Output Channel Compressor groups: m, n, o, and p.

- 1 Use the DISPLAY ACCESS [GROUP] button to locate the Output Comp Link page.

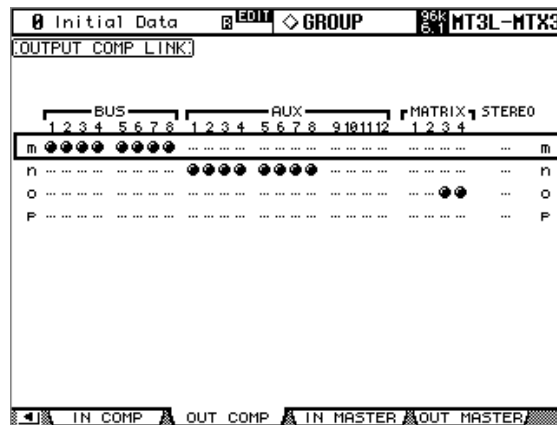

- 2 Press the LAYER [MASTER] button.
- 3 Use the Up/Down cursor buttons to select Comp groups m–p.  
The selected group is highlighted by a flashing cursor box.
- 4 Use the [SEL] buttons to add and remove Output Channels to and from the selected group.

The Compressor settings of the first Output Channel added to the group are applied to all subsequently added Output Channels.

When an Output Channel is added to a group, its [SEL] button indicator lights up.

## Delaying Channel Signals

Input Channels, Bus Outs, Aux Sends, Matrix Sends, and the Stereo Out all feature independent Delay functions. Input Channel Delays feature feedback, with independent Mix and Gain parameters.

### Using the SELECTED CHANNEL DELAY Controls

- 1 Use the LAYER buttons to select Layers, and use the [SEL] buttons to select channels.

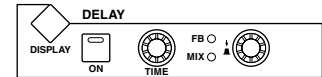

Use the STEREO [SEL] button to toggle between the left and right channels of the Stereo Out. On the Master Layer, use [SEL] buttons 21–24 to toggle between the left and right channels of the Matrix Sends.

- 2 Use the [ON] button to turn the Delay function on and off.
- 3 Use the TIME control to set the delay time.

If the currently selected channel is an Input Channel, you can also set the Feedback Gain (FB) and Feedback Mix (MIX) parameters. Use the FB/MIX push switch to select either FB or MIX, and use the FB/MIX control to set it.

### Delay Pages

Delay settings can be viewed and set on the Delay pages. If the Auto DELAY Display preference is on, these pages appear automatically when a control in the SELECTED CHANNEL DELAY section is operated. See “Auto DELAY Display” on page 274.

- 1 Use the SELECTED CHANNEL DELAY [DISPLAY] button to select the Delay pages.

The Delay parameters for the 96 Input Channels are arranged into four pages. The Input Channel 1–24 Delay page is shown below. The layout of the other three pages is the same.

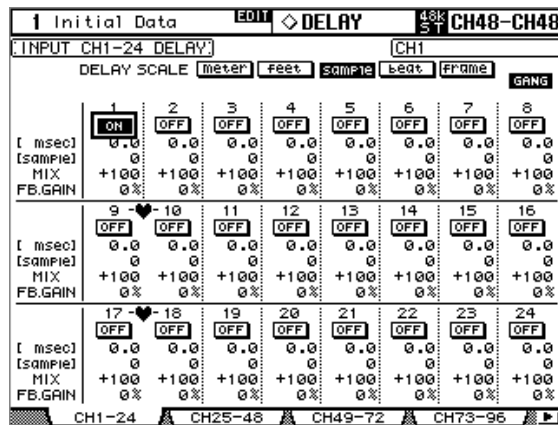

The Delay parameters for the Bus Outs, Aux Sends, Matrix Sends, and the Stereo Out appear on the Output Delay page.

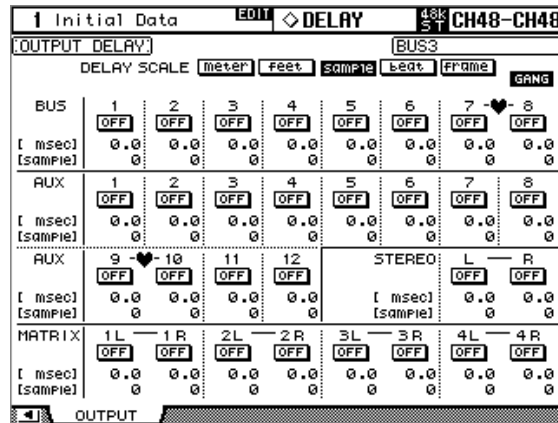

- 2 Use the cursor buttons to select the Delay parameters, and use the Parameter wheel, INC/DEC buttons, and [ENTER] button to set them.

Input and Output Channels can also be selected by using the LAYER and [SEL] buttons.

**DELAY SCALE:** These buttons determine the units of the delay value shown below the msec value. Units can be set to meters, feet, samples, beats, or timecode frames.

**GANG:** When this option is turned on, the delay time for paired channels can be set simultaneously. Ganging is relative, so any delay time difference between the two channels is maintained when this is turned on.

**ON/OFF:** These buttons turn the individual Delay functions on and off. The [ENTER] button can be used to turn a Delay on and off regardless of which parameter is selected.

**msec:** This sets the delay time in milliseconds. The delay time can also be set by using the parameter below, which is the delay time in the units selected by the DELAY SCALE buttons. You can copy the currently selected Input or Output Channel delay setting to all Input or Output Channels respectively by double-clicking the [ENTER] button.

**MIX:** This parameter, available only on the Input Channel Delay pages, sets the mix of dry and wet signals.

**FB.GAIN:** This parameter, available only on the Input Channel Delay pages, sets the amount of feedback.

## Soloing Channels

Input Channels, Bus Outs, Aux Sends, and Matrix Sends can be soloed as follows.

- 1 Use the LAYER buttons to select the Input Channel Layers if you want to solo Input Channels, or select the Master Layer if you want to solo Output Channels.

Input and Output Channels cannot be soloed simultaneously. Soloed Input Channels will be unsoloed when an Output Channel is soloed, and vice versa.

- 2 Use the [SOLO] buttons to solo the channels on the selected Layer.



The [SOLO] button indicators of channels that are soloed light up.

The SOLO indicator in the MONITOR section flashes when the Solo function is active. You can unsolo all soloed channels by pressing the SOLO [CLEAR] button. You can adjust the level contrast between the soloed channels and the currently selected Control Room Monitor source by adjusting the SOLO CONTRAST control.

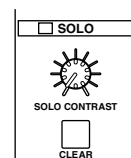

## Configuring Solo

The Solo function is configured on the Solo Setup page. If the Auto SOLO Display preference is on, this page appears automatically when a channel is soloed. See “Auto SOLO Display” on page 275.

- 1 Use the MONITOR [DISPLAY] button to locate the Solo Setup page.

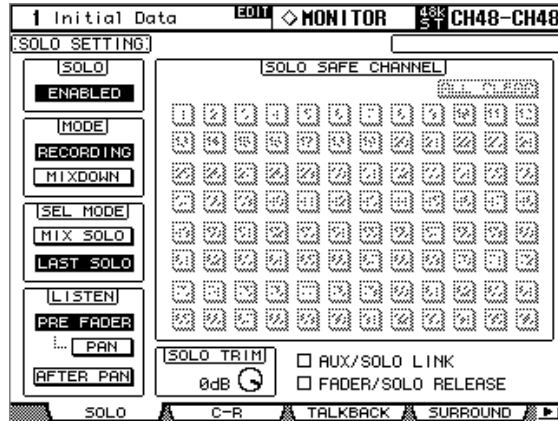

- 2 Use the cursor buttons to select the parameters, and use the Parameter wheel, INC/DEC buttons, and [ENTER] button to set them.

**SOLO:** This is used to enable and disable the Solo function.

**STATUS:** This determines the Solo mode: Recording or Mixdown.

In Recording Solo mode, soloed Input Channel signals are fed to the Solo bus and output via the Control Room Outputs. Other buses are unaffected by this mode. If the Listen parameter is set to AFTER PAN, the signal source for Input Channels that are off, is pre fader.

In Mixdown Solo mode, soloed Input Channel signals are fed to the Stereo bus and output via the Stereo Out and Control Room Outputs. Unsoloed Input Channels are muted and their [ON] button indicators flash (unless they are Solo Safe enabled). Only Input Channels that are routed to the Stereo Out can be soloed in this mode. Input Channels that are off are temporarily turned on when they are soloed.

**SEL MODE:** This determines the Solo Select mode: Mix Solo or Last Solo. In Mix Solo mode, any number of channels can be soloed simultaneously. In Last Solo mode, only one channel can be soloed at a time.

**LISTEN:** This determines the source of the Input Channel Solo signal: Pre Fader or After Pan. This parameter does not affect Mixdown Solo mode. Output Channels are fixed at After Pan. If you select Pre Fader, turning on the PAN button below it enables you to solo the channel with the Pan setting still applied.

**SOLO TRIM:** This is used to trim the level of the Solo signal. This parameter does not affect Mixdown Solo mode.

**SOLO SAFE CHANNEL:** For Mixdown Solo mode, Input Channels can be configured individually so that they are not muted when other Input Channels are soloed. Use the [SEL] buttons, cursor buttons, or Parameter wheel to select the SOLO SAFE CHANNEL buttons. Use the [ENTER] or INC/DEC buttons to set Solo Safe for each Input Channel. These settings do not affect Recording Solo mode. You can clear all Solo Safe settings by selecting the ALL CLEAR button and pressing [ENTER].

**AUX/SOLO LINK:** When this check box is checked, you can solo or unsolo the Aux Sends using the AUX SELECT [AUX 1]–[AUX 12] buttons without changing the Master layer. This is convenient when you want to solo or unsolo Aux Outs while controlling the Aux Sends from the Input Channels. Press the AUX SELECT key for the AUX send that you want to solo, making it light. Then press that key once again to solo only the selected AUX send. When Aux Sends are soloed, the corresponding AUX SELECT button indicators flash.

**FADER/SOLO RELEASE:** When you check this check box, raising the channel faders of soloed Channels from  $-\infty$  will unsolo the Channels. If the channel fader position is higher than  $-\infty$ , you cannot solo the corresponding channel.

This function is disabled in Mixdown Solo mode and for the Output Channels.

*Note: When the AUX/SOLO LINK or FADER/SOLO RELEASE check box is checked, the solo setting is cancelled.*

## Pairing Channels

Input Channels, Bus Outs, and Aux Sends can be paired for stereo operation. Input Channels can be paired either horizontally, that is, adjacent odd-even channels on the same Layer (e.g., 1-2, 3-4, 5-6, etc) or vertically, that is, counterpart channels on adjacent Layers (e.g., 1-25, 2-26, 49-73, 50-74, etc). Bus Outs and Aux Sends can be paired only horizontally.

### Pairing Channels by Using the [SEL] Buttons

Only horizontal pairing can be set by using the [SEL] buttons.

- 1 **Use the LAYER buttons to select the Layer containing the channels that you want to pair.**
- 2 **While holding down the [SEL] button of the first channel, press the [SEL] button of the second channel.**

The settings of the first channel are copied to the second channel and the channels are paired. The [SEL] button indicator of the currently selected channel lights up, while the [SEL] button indicator of the other channel flashes.

To cancel a pair, while holding down the [SEL] button of the first channel, press the [SEL] button of the second channel.

The following channel parameters are copied, and controlled together, when channels are paired: Fader, On/Off, Insert On/Off, Aux/Matrix On/Off, Aux Send Mode, Aux/Matrix Send Level, Aux/Matrix Pre/Post, Aux Pre Point, Gate parameters, Compressor parameters, Comp Position, EQ parameters, Fader group, Mute group, EQ group, Comp group, Solo, Solo Safe, [AUTO] button, Fade Time, Recall Safe, Bus to Stereo On/Off, Bus to Stereo Level.

The following channel parameters are not copied, or controlled together, when channels are paired: Input Patch, Insert Patch, Output Patch, Phase, Delay On/Off, Delay Time, Delay Feedback, Delay Mix, Routing, Pan, Follow Pan, Surround Pan, Bus to Stereo Pan, Aux/Matrix Send Pan, Balance.

When channels are paired, the Attenuator value is copied, but the changes made in the Attenuator page are not reflected in the pair partner. However, if you change the values in the EQ Edit page, Parameter view page, or on the control surface, the changes will be reflected in the pair partner while maintaining the relative level difference.

When Aux Send Mode is set to Fixed, Aux Send On/Off is not controlled together.

Check the Routing ST Pair Link check box to link the routing from the paired channels to the Stereo Bus. See “Setting Preferences” on page 274 for more information.



## Pairing Channels by Using the Pair Pages

Both horizontal and vertical pairing can be set on the Pair pages.

### 1 Use the DISPLAY ACCESS [PAIR] button to locate the Pair pages.

The Pair parameters for the 96 Input Channels are divided between two pages. The Input Channel 1–48 Pair page is shown below. The layout of the other page is the same.

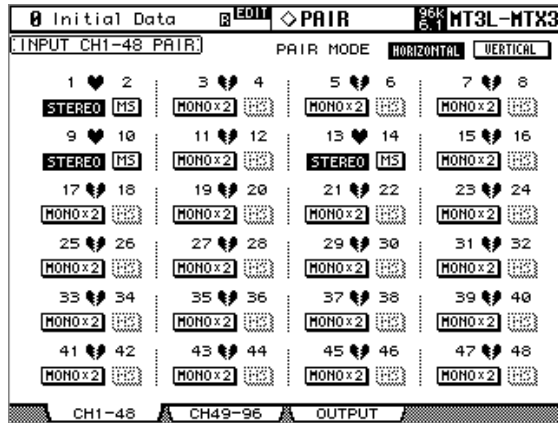

### 2 To set the pair mode, select the PAIR MODE HORIZONTAL or VERTICAL buttons, and press [ENTER].

The Pair mode can be set independently for Input Channels 1–48 and Input Channels 49–96. The Input Channel 1–48 Pair page in Vertical mode is shown below.

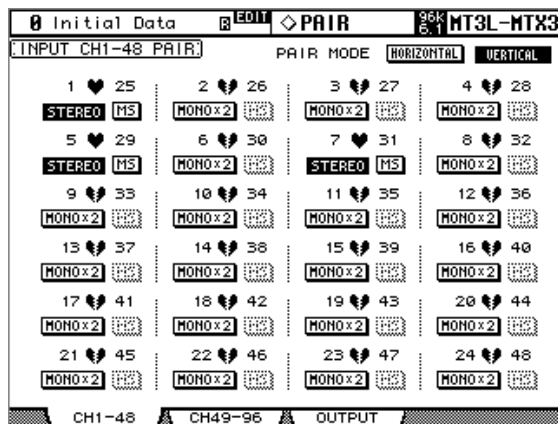

Pair parameters for the Bus Outs and Aux Sends appear on the Output Pair page.

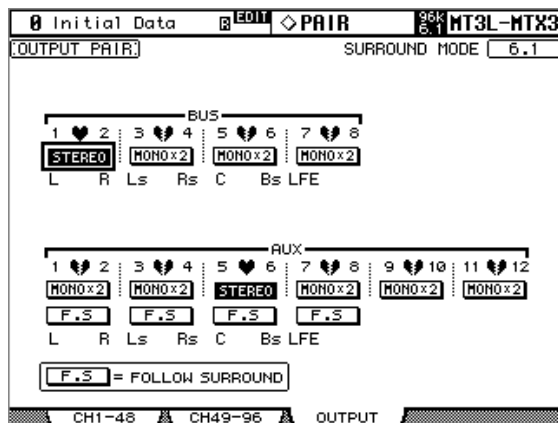

**3 Use the cursor buttons or Parameter wheel to select the channel pair buttons, and press [ENTER] to make or break pairs.**

Input and Output Channels can also be selected by using the LAYER and [SEL] buttons.

A dialog box appears with options for copying the settings of the first channel to the second channel, the second channel to the first channel, and for resetting both channels to their initial settings. Choose the option required, and then press [ENTER].

On other display pages, paired channels have a heart icon, or a dash between their channel numbers.

When Input Channels are paired, MS Decoding can be used to decode signals from microphones arranged as MS pairs. MS Decoding is set on the Input Channel Pair pages. This can be turned on and off for each pair of channels by using the MS buttons.

The Output Pair page displays the currently selected Surround mode (i.e., Stereo, 3-1, 5.1, or 6.1), which can be set on the Surround Mode page (see page 97). When a Surround mode other than Stereo is selected, the names of the Surround channels are shown below the Bus Out and Aux Send pair buttons, as shown in the following table.

Surround Mode	Bus Out/Aux Send							
	1	2	3	4	5	6	7	8
3-1	L	R	C	S	—	—	—	—
5.1	L	R	Ls	Rs	C	LFE	—	—
6.1	L	R	Ls	Rs	C	Bs	LFE	—

This table shows the default assignment. The assignment may vary depending on the settings in the Surround Bus Setup page (see page 99).

When a Surround mode other than Stereo is selected, Aux Sends can be set to follow the same Input Channel Surround Pan that applies to the Bus Outs, which is useful for feeding Surround channel signals to external effects processors. This is turned on and off by using the F.S buttons that appear below the Aux Send Pair buttons. When a pair of Aux Sends are set to follow Surround Pan, their Aux Send Pair button is unavailable, and their Aux Pan parameters (see page 116) are unavailable.

### Grouping Output Channel Faders

The Bus Out, Aux Send, Matrix Send, and Stereo Out faders can be grouped, allowing you to control the level of several Output Channels simultaneously. There are four Output Channel Fader groups: Q, R, S, and T.

**1 Use the DISPLAY ACCESS [GROUP] button to locate the Output Fader Group page.**

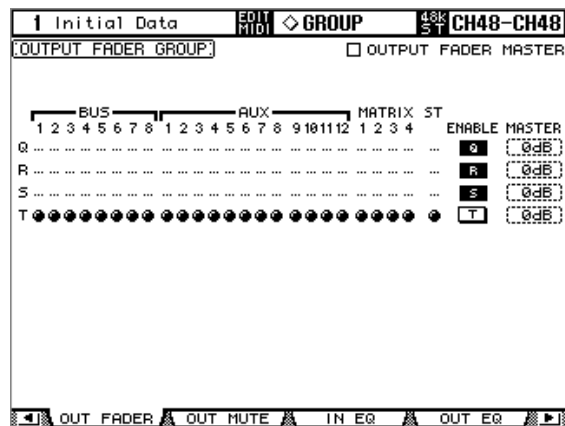

- 2 Press the LAYER [MASTER] button.**
- 3 Use the Up/Down cursor buttons to select Fader groups Q–T.**  
The selected group is highlighted by a flashing cursor box.
- 4 Use the [SEL] buttons to add and remove Output Channel faders to and from the selected group.**

When an Output Channel is added to a group, its [SEL] button indicator lights up.

**ENABLE:** These buttons are used to enable and disable the groups.

**OUTPUT FADER MASTER:** When this check box is not checked, the Output Channel fader positions determine the fader levels in the Output Channel Fader groups. When this check box is checked, you can set the master level for the corresponding Output Channel Fader group in the Master column. The resultant Output Channel level equals the corresponding Output Channel fader level plus the Group master level. See “Group Master for the Output Channel Faders” on page 147 for more information.

When the Output Fader Master check box is not checked, operating the channel faders will affect the Output Channel levels in the corresponding Fader group. Pressing and holding down the [SEL] button while operating the fader of an Output Channel will temporarily cancel the corresponding Fader group, which is convenient if you want to adjust the relative balance between channels.

Fader groups are active only in Fader mode. See “Selecting Fader Modes” on page 60 for more information.

## Group Master for the Output Channel Faders

The DM2000 also features a Fader Group Master function that enables you to control the level of all channels using the Group Master level while maintaining the balance between the channels, much like a VCA Group on an analog mixing console. While this function is enabled, channel fader operation will not affect the channel levels of the corresponding Fader group.

- 1 Follow Steps 1–4 as described in the “Grouping Output Channel Faders” section on the previous page, select the Output Fader Master check box, then press the [ENTER] button to check or uncheck the Output Fader Master check box.**
- 2 When the Output Fader Master check box is checked, you can set the channel levels of the Fader groups in the Master column.**

When the Master column is selected, repeatedly pressing the [ENTER] button turns the Output Fader Group on and off.

You can also make these settings in the Output Fader Group Master page, as shown below.

- 3 Use the **DISPLAY ACCESS [GROUP]** button to locate the **Output Fader Group Master** page.

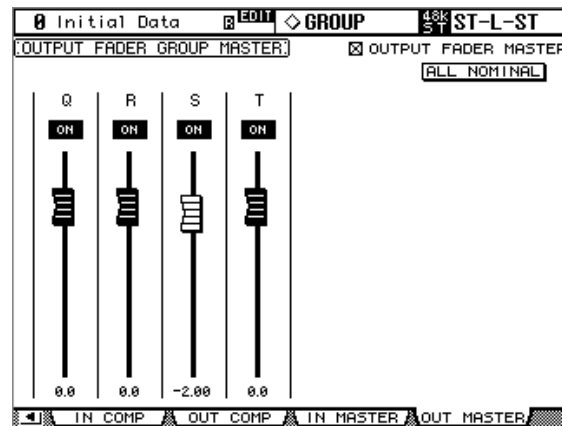

- 4 Use the cursor buttons to select the parameters, then use the Parameter wheel, INC/DEC buttons or [ENTER] button to set them.

**OUTPUT FADER MASTER:** When this check box is checked, you can set the master levels for the Output Fader groups. The resultant Output Channel level equals the corresponding Output Channel fader level plus the Group master level.

**ALL NOMINAL:** This button resets the master levels for all Output Fader groups to nominal.

**ON/OFF:** This turns each Output Fader group on or off, like a VCA mute on an analog mixing console.

**Faders:** These faders adjust the master levels of the Fader groups. Fader knobs appear highlighted when faders are set to 0.0 dB. Press the [ENTER] button to set the currently-selected fader to 0.0 dB.

You can also control the Fader Master function from the channel strips on the control surface as described below by using the User Assignable Layer of the Remote Layers. See page 269 for information on the User Assignable Layer.

**Encoders:** The Encoders are not available.

**[AUTO] buttons:** These buttons are used to control the Fader Group Master On/Off and the master level during Automix.

**[SEL] buttons:** These buttons move the cursor on the Output Fader Group Master page.

**[SOLO] buttons:** These buttons turn the Solo function of each Fader group on and off, enabling you to monitor every channel in each Fader group.

**Channel Strip Displays:** The displays indicate the Group names (GrpQ–GrpT). When you operate the channel faders, the displays indicate the corresponding master level values.

**Channel Faders:** The Channel Faders enable you to set the master level for each Fader group.

## Grouping Output Channel Mutes (ON/OFF)

The Bus Out, Aux Send, Matrix Send, and Stereo Out mutes can be grouped, allowing you to mute several Output Channels simultaneously. There are four Output Channel Mute groups: U, V, W, and X.

- 1 Use the **DISPLAY ACCESS [GROUP]** button to locate the **Output Mute Group** page.

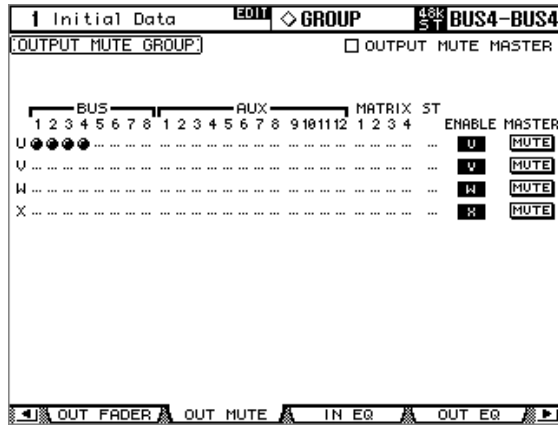

- 2 Press the **LAYER [MASTER]** button.
- 3 Use the **Up/Down** cursor buttons to select Mute groups U–X.  
The selected group is highlighted by a flashing cursor box.
- 4 Use the **[SEL]** buttons to add and remove Output Channels to and from the selected group.

When an Output Channel is added to a Mute group, its [SEL] button indicator lights up.

**ENABLE:** These buttons are used to enable and disable the groups.

**OUTPUT MUTE MASTER:** When this check box is checked, pressing the MASTER MUTE button turns mute on or off for all channels in the corresponding Mute group. When this check box is unchecked, the Output Channel [ON] button status mutes or unmutes the channels in the group.

**MASTER MUTE:** When the Output Mute Master check box is checked, use this button to mute or unmute all channels in the corresponding Mute group.

When the Output Mute Master check box is unchecked, pressing the Output Channel [ON] button mutes or unmutes the channel in the corresponding Mute group (Mute On channels are turned off and Mute Off channels are turned on).

## Output Channel Mute Master

The DM2000 features a Mute Group Master function that enables you to mute all channels in the Mute group using the MASTER button, much like a Mute group on an analog mixing console. When this function is enabled, the channel [ON] buttons do not control the channels in the group collectively.

- 1 Follow Steps 1–4 described in the “Grouping Output Channel Mutes (ON/OFF)” section on the previous page, select the **Output Mute Master** check box, then press the **[ENTER]** button to check or uncheck the **Output Mute Master** check box.
- 2 When the **Output Mute Master** check box is checked, the **MASTER MUTE** button in each group mutes or unmutes the channels in the corresponding group.  
If the channels are muted by the Mute Master function, the corresponding channel [ON] button indicators flash. You can assign the MASTER MUTE button function to one of the USER DEFINED KEYS for convenient operation.

## Viewing Channel Parameter Settings

The parameter setting of the currently selected Input Channel, Bus Out, Aux Send, Matrix Send, or the Stereo Out can be viewed and set on the Parameter View pages.

- 1 Use the **DISPLAY ACCESS [VIEW]** button to select the **Parameter View** page.
- 2 Use the **LAYER** buttons to select Layers, and use the **[SEL]** buttons to select channels.
- 3 Use the **cursor buttons** to select the parameters, and use the **Parameter wheel**, **INC/DEC** buttons, and **[ENTER]** buttons to set them.

### Input Channels

This is the Parameter View page for the Input Channels.

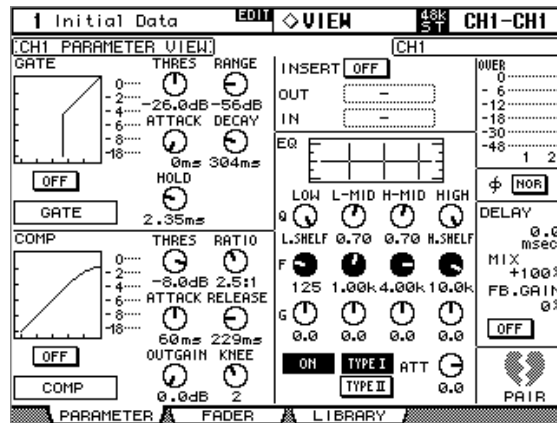

**GATE:** The following Gate parameters for the currently selected Input Channel can be set: Gate On/Off, Threshold, Range, Attack, Decay, and Hold. The GR meter indicates the amount of gain reduction being applied by the Gate. Also displayed are the gate curve and gate type. See “Gating Input Channels” on page 85 for more information.

**COMP:** The following Compressor parameters for the currently selected channel can be set: Comp On/Off, Threshold, Ratio, Attack, Release, Gain, and Knee. The GR meter indicates the amount of gain reduction being applied by the Compressor. Also displayed are the comp curve and comp type. See “Compressing Channels” on page 137 for more information.

**INSERT:** The currently selected channel’s Insert can be turned on and off and patched. See “Using Inserts” on page 135 for more information.

**EQ:** The currently selected channel’s EQ and Attenuator can be set. Also displayed is the EQ curve of the currently selected Input Channel. See “Using EQ” on page 131 for more information.

**Meters:** These meters indicate the levels of the currently selected channel and its horizontal or vertical partner.

**Phase:** The signal phase of the currently selected Input Channel can be reversed. See “Reversing the Signal Phase” on page 84 for more information.

**DELAY:** The currently selected channel’s Delay function can be set. See “Delaying Channel Signals” on page 141 for more information.

**PAIR:** This heart icon indicates whether or not channels are paired. See “Pairing Channels” on page 144 for more information.

## Output Channels

This is the Parameter View page for the Bus Outs, Aux Sends, Matrix Sends, and the Stereo Out. Parameters are the same as for the Input Channel Parameter View page, minus the GATE and Phase sections and the DELAY MIX and FB GAIN parameters. The parameter settings of the left and right channels of the Matrix Sends and Stereo Out can be viewed individually. Use the [SEL] buttons to toggle between the left and right channels.

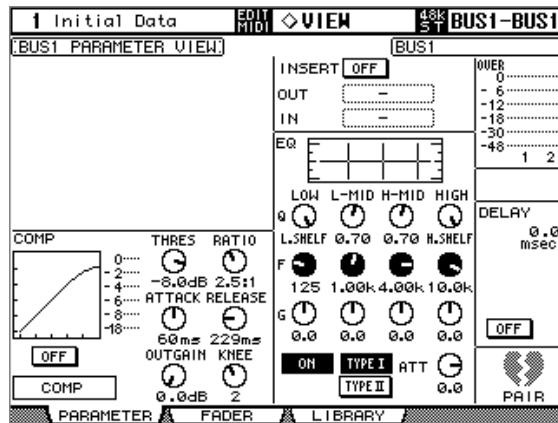

## Viewing Channel Fader Settings

The fader-related settings of the currently selected Input Channel, Bus Out, Aux Send, Matrix Send, or the Stereo Out can be viewed and set on the Fader View pages.

- 1 Use the DISPLAY ACCESS [VIEW] button to select the Fader View page.
- 2 Use the LAYER buttons to select Layers, and use the [SEL] buttons to select channels.
- 3 Use the cursor buttons to select the parameters, and use the Parameter wheel, INC/DEC buttons, and [ENTER] buttons to set them.

Pan and Balance controls can be set to center by pressing [ENTER] while they're selected.

## Input Channels

This is the Fader View page for the Input Channels.

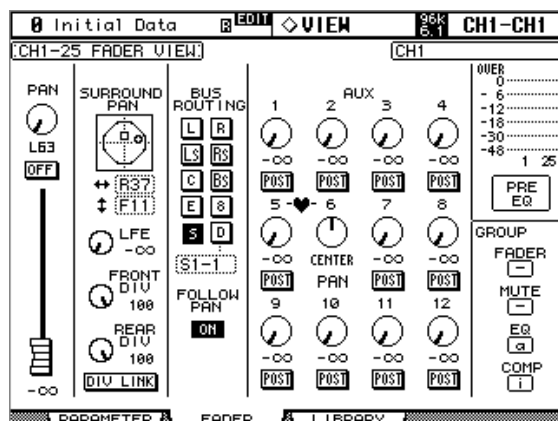

**PAN:** This is the currently selected Input Channel's Pan parameter. Select this parameter using the cursor buttons, then press the [ENTER] button to set the Pan parameter to Center. See "Panning Input Channels" on page 95 for more information.

**ON/OFF:** This is the On/Off parameter of the currently selected Input Channel. See "Muting Input Channels (ON/OFF)" on page 88 for more information.

**Fader:** This indicates the fader position of the currently selected Input Channel. The fader knob appears highlighted when the fader is set to 0.0 dB. The fader position is displayed numerically below the fader. See “Setting Input Channel Levels” on page 90 for more information.

**SURROUND PAN:** The Surround pan parameters for the currently selected Input Channel are displayed only when a Surround mode other than Stereo is selected. See “Using Surround Pan” on page 97 for more information.

**BUS ROUTING:** This section contains Routing and Follow Pan buttons for the currently selected Input Channel. See “Routing Input Channels” on page 93 for more information. The Direct Out output patch can also be set. See “Patching Direct Outs” on page 81 for more information.

**AUX:** These are the currently selected Input Channel’s Aux Send Level, On/Off, and Pre/Post parameters. While a rotary control is selected, the Aux Send can be turned on and off by pressing [ENTER]. See “Aux Sends” on page 110 for more information.

**Meters:** These meters indicate the levels of the currently selected Input Channel and its horizontal or vertical partner. The metering position is displayed below them.

**GROUP:** These buttons indicate which Fader, Mute, EQ, or Comp group, if any, the currently selected Input Channel is in.

## Bus Outs

This is the Fader View page for the Bus Outs.

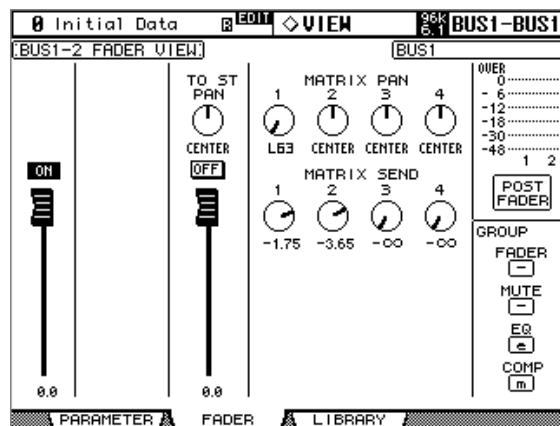

**ON/OFF:** This is the On/Off parameter of the currently selected Bus Out. See “Muting Bus Outs (ON/OFF)” on page 108 for more information.

**Fader:** This indicates the fader position of the currently selected Bus Out. The fader knob appears highlighted when the fader is set to 0.0 dB. The fader position is displayed numerically below the fader. See “Setting Bus Out Levels” on page 108 for more information.

**TO ST PAN, ON/OFF & Fader:** These are the Bus Out to Stereo Out Pan, On/Off, and Fader parameters for the currently selected Bus Out. The fader knob appears highlighted when the fader is set to 0.0 dB. The fader position is displayed numerically below the fader. See “Sending Bus Outs to the Stereo Out” on page 109 for more information.

**MATRIX PAN:** These are the Matrix Send Pan controls for the currently selected Bus Out. See “Panning Matrix Sends” on page 123 for more information.

**MATRIX SEND:** These are the Matrix Send Level controls for the currently selected Bus Out. While a rotary control is selected, the Matrix Send can be turned on and off by pressing [ENTER]. See “Setting Matrix Send Levels” on page 121 for more information.

**Meters:** These meters indicate the levels of the currently selected Bus Out and its partner. The metering position is displayed below them.

**GROUP:** These buttons indicate which Fader, Mute, EQ, or Comp group, if any, the currently selected Bus Out is in.



## Aux Sends

Below is the Fader View page for the Aux Sends.

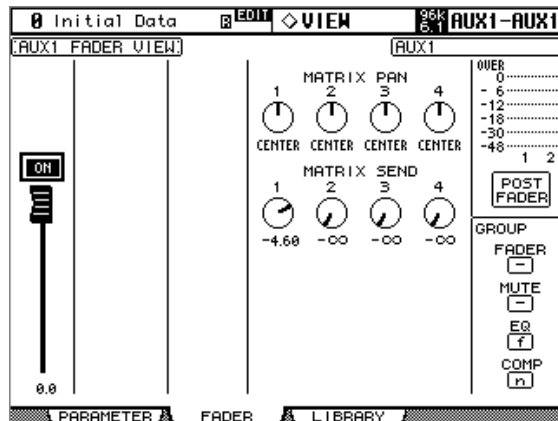

**ON/OFF:** This is the On/Off parameter of the currently selected Aux Send. See “Muting Aux Sends (ON/OFF)” on page 112 for more information.

**Fader:** This indicates the fader position of the currently selected Aux Send. The fader knob appears highlighted when the fader is set to 0.0 dB. The fader position is displayed numerically below the fader. See “Settings Aux Send Master Levels” on page 119 for more information.

**MATRIX PAN:** These are the Matrix Send Pan controls for the currently selected Aux Send. See “Panning Matrix Sends” on page 123 for more information.

**MATRIX SEND:** These are the Matrix Send Level controls for the currently selected Aux Send. While a rotary control is selected, the Matrix Send can be turned on and off by pressing [ENTER]. See “Setting Matrix Send Levels” on page 121 for more information.

**Meters:** These meters indicate the levels of the currently selected Aux Send and its partner. The metering position is displayed below them.

**GROUP:** These buttons indicate which Fader, Mute, EQ, or Comp group, if any, the currently selected Aux Send is in.

## Matrix Sends

Below is the Fader View page for the Matrix Sends. The settings of the left and right channels of the Matrix Sends can be viewed individually. Use [SEL] buttons 1–24 to toggle between the left and right channels.

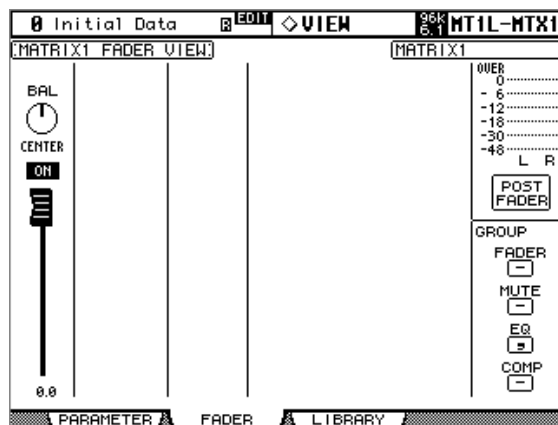

**BAL:** This is the Balance parameter for the currently selected Matrix Send. See “Balancing Matrix Send Masters” on page 126 for more information.

**ON/OFF:** This is the On/Off parameter of the currently selected Matrix Send. See “Muting Matrix Sends (ON/OFF)” on page 122 for more information.

**Fader:** This indicates the fader position of the currently selected Matrix Send. The fader knob appears highlighted when the fader is set to 0.0 dB. The fader position is displayed numerically below the fader. See “Setting Matrix Send Master Levels” on page 125 for more information.

**Meters:** These meters indicate the levels of the currently selected Matrix Send and its partner. The metering position is displayed below them.

**GROUP:** These buttons indicate which Fader, Mute, EQ, or Comp group, if any, the currently selected Matrix Send is in.

### Stereo Out

Below is the Fader View page for the Stereo Out. The settings of the left and right channels of the Stereo Out can be viewed individually. Use the STEREO [SEL] button to toggle between the left and right channels.

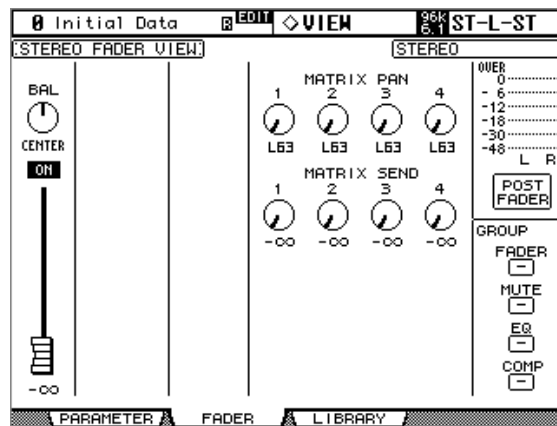

**BAL:** This is the Balance parameter for the Stereo Out. Select this parameter using the cursor buttons, then press the [ENTER] button to set the parameter to Center. See “Balancing the Stereo Out” on page 106 for more information.

**ON/OFF:** This is the On/Off parameter of the Stereo Out. See “Muting the Stereo Out (ON/OFF)” on page 105 for more information.

**Fader:** This indicates the fader position of the Stereo Out. The fader knob appears highlighted when the fader is set to 0.0 dB. The fader position is displayed numerically below the fader. See “Setting the Stereo Out Level” on page 105 for more information.

**MATRIX PAN:** These are the Matrix Send Pan controls for the Stereo Out. They can be set independently for the Stereo Out’s left and right channels. See “Panning Matrix Sends” on page 123 for more information.

**MATRIX SEND:** These are the Matrix Send Level controls for the Stereo Out. They can be set independently for the Stereo Out’s left and right channels. While a rotary control is selected, the Matrix Send can be turned on and off by pressing [ENTER]. See “Setting Matrix Send Levels” on page 121 for more information.

**Meters:** These meters indicate the levels of the Stereo Out. The metering position is displayed below them.

**GROUP:** These buttons indicate which Fader, Mute, EQ, or Comp group, if any, the Stereo Out is in.

## Copying Channel Settings

The settings of Input Channels, Bus Outs, Aux Sends, Matrix Sends, and the Stereo Out can be copied among channels of the same type by using the Channel Copy function. You can even copy to and from channels in Scenes without recalling them. For the Matrix Sends and Stereo Out, the left and right channels are copied and pasted independently.

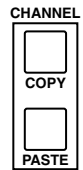

The Channel Copy Parameter buttons on the Preferences 2 page allow you to specify which channel settings will be copied. See “Channel Copy Parameter” on page 276.

### Copying Channel Settings in the Same Scene

- 1 Use the LAYER and [SEL] buttons to select the source channel.

- 2 Press the CHANNEL [COPY] button.

The settings of the currently selected channel are copied to the Copy buffer.

For paired channels, only the settings of the currently selected channel are copied.

- 3 Use the LAYER and [SEL] buttons to select the destination channel.

- 4 Press the CHANNEL [PASTE] button.

If the destination channel is of the same type as the source channel, the settings in the Copy buffer are pasted to the destination channel and its settings are updated accordingly.

### Copying Channel Settings from the Current Scene to Other Scenes

- 1 Use the LAYER and [SEL] buttons to select the source channel.

- 2 Press the CHANNEL [COPY] button.

- 3 Use the SCENE MEMORY Up [▲] and Down [▼] buttons to select the destination Scene.

The number of the destination Scene flashes on the SCENE MEMORY display.

- 4 Use the LAYER and [SEL] buttons to select the destination channel.

- 5 Press the CHANNEL [PASTE] button.

A confirmation message appears. Choose YES to copy the source channel settings to the destination channel.

### Copying Channel Settings from Other Scenes to the Current Scene

- 1 Use the SCENE MEMORY Up [▲] and Down [▼] buttons to select the source Scene.

The number of the source Scene flashes on the SCENE MEMORY display.

- 2 Use the LAYER and [SEL] buttons to select the source channel.

- 3 Press the CHANNEL [COPY] button.

- 4 Use the SCENE MEMORY Up [▲] and Down [▼] buttons to select the current Scene.

The number of the current Scene lights up on the SCENE MEMORY display.

- 5 Use the LAYER and [SEL] buttons to select the destination channel.

- 6 Press the CHANNEL [PASTE] button.

The source channel settings are copied to the destination channel.

### Copying Channel Settings Between Noncurrent Scenes

- 1 **Use the SCENE MEMORY Up [▲] and Down [▼] buttons to select the source Scene.**  
The number of the source Scene flashes on the SCENE MEMORY display.
- 2 **Use the LAYER and [SEL] buttons to select the source channel.**
- 3 **Press the CHANNEL [COPY] button.**
- 4 **Use the SCENE MEMORY Up [▲] and Down [▼] buttons to select the destination Scene.**  
The number of the destination Scene flashes on the SCENE MEMORY display.
- 5 **Use the LAYER and [SEL] buttons to select the destination channel.**
- 6 **Press the CHANNEL [PASTE] button.**  
A confirmation message appears. Choose YES to copy the source channel settings to the destination channel.

### Naming Channels

You can specify Long and Short names for the Input Channels, Bus Outs, Aux Sends, Matrix Sends, and the Stereo Out as follows.

See page 298 for a list of initial Input Channel names; page 299 for Output Channel names.

#### Input Channels

- 1 **Use the DISPLAY ACCESS [INPUT PATCH] button to locate the Input Channel Name page.**

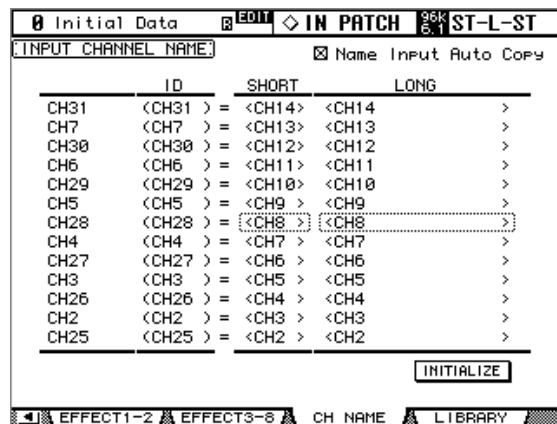

- 2 **Use the Parameter wheel, INC/DEC buttons, or the LAYER and [SEL] buttons to select the Input Channels.**  
When Vertical Input Channel pairing mode is selected, Input Channels are listed in order of vertical partners, for example, CH1, CH25, CH2, CH26, and so on.
- 3 **Use the cursor buttons to select the Input Channel's Long or Short name, and then press [ENTER].**  
When the Title Edit window appears, edit the Input Channel name, and press OK when you've finished. See "Title Edit Window" on page 54 for more information.  
You can reset all Input Channel names back to their initial values by pressing the INITIALIZE button.

If the Name Input Auto Copy check box in the upper right corner is checked, the first four characters of the name entered in the LONG column are automatically copied to the SHORT column. Also, a name entered in the SHORT column is automatically copied to the LONG column.

### Output Channels

- 1 Use the DISPLAY ACCESS [OUTPUT PATCH] button to locate the Output Channel Name page

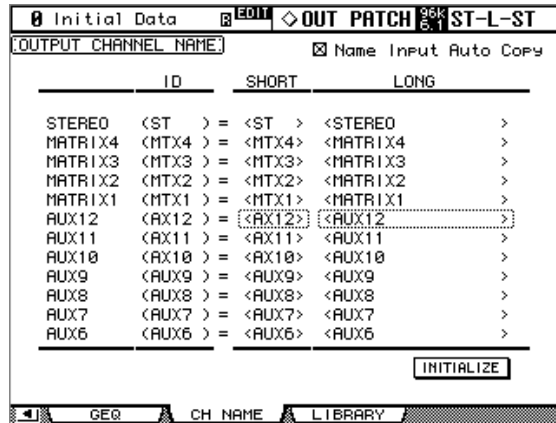

- 2 Use the Parameter wheel, INC/DEC buttons, or the Master Layer and [SEL] buttons to select the Output Channels.
- 3 Use the cursor buttons to select the Output Channel's Long or Short name, and then press [ENTER].

When the Title Edit window appears, edit the Output Channel name, and press OK when you've finished. See "Title Edit Window" on page 54 for more information.

You can reset all Output Channel names back to their initial values by pressing the INITIALIZE button.

If the Name Input Auto Copy check box in the upper right corner is checked, the first four characters of the name entered in the LONG column are automatically copied to the SHORT column. Also, a name entered in the SHORT column is automatically copied to the LONG column.

# 13 Monitoring & Talkback

## Control Room Monitoring

The DM2000 features independent outputs and level controls for two sets of studio monitors. The LARGE CONTROL ROOM MONITOR OUT +4 dB (BAL) XLR-3-32-type connectors are intended to feed to the control room’s main monitors. The SMALL CONTROL ROOM MONITOR OUT +4 dB (BAL) XLR-3-32-type connectors are intended to feed to the control room’s nearfield monitors.

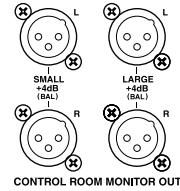

The Control Room Monitor signal source is selected by using the CONTROL ROOM STEREO buttons.

- [2TR D1]:** Selects the 2TR IN DIGITAL AES/EBU 1.
- [2TR D2]:** Selects the 2TR IN DIGITAL AES/EBU 2.
- [2TR D3]:** Selects the 2TR IN DIGITAL COAXIAL 3.
- [2TR A1]:** Selects the 2TR IN ANALOG 1.
- [2TR A2]:** Selects the 2TR IN ANALOG 2.
- [STEREO]:** Selects the Stereo Out.

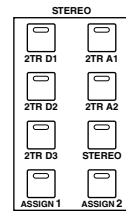

- [ASSIGN 1]:** Selects the Output Channel assigned to this button on the Control Room Setup page. See “Control Room Setup” on page 159.
- [ASSIGN 2]:** Selects the Output Channel assigned to this button on the Control Room Setup page. See “Control Room Setup” on page 159.

The level of the Control Room Monitor signal can be set by using the CONTROL ROOM LEVEL control. You can toggle between the LARGE CONTROL ROOM MONITOR OUT and SMALL CONTROL ROOM MONITOR OUT by using the CONTROL ROOM [SMALL] button, whose indicator is off when LARGE is selected, and on when SMALL is selected. The Control Room Monitor signal can be switched into mono by using the CONTROL ROOM [MONO] button. The [DIMMER] button activates the Dimmer function, which dims the Control Room Monitor and Surround Monitor signals by the amount specified on the Control Room Setup page (page 159). The Dimmer function is activated automatically when the Slate, Talkback, or Oscillator function is active.

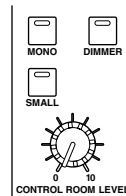

The level of the SMALL CONTROL ROOM MONITOR OUT can be set by using the SMALL TRIM control. When set at maximum, the level is the same as that of the LARGE CONTROL ROOM MONITOR OUT.



The Control Room Monitor signal is also fed to the PHONES jack, the level of which is set by using the PHONES LEVEL control.

## Control Room Setup

Control room monitoring is configured on the Control Room Setup page.

- 1 Use the **MONITOR [DISPLAY]** button to locate the Control Room Setup page.

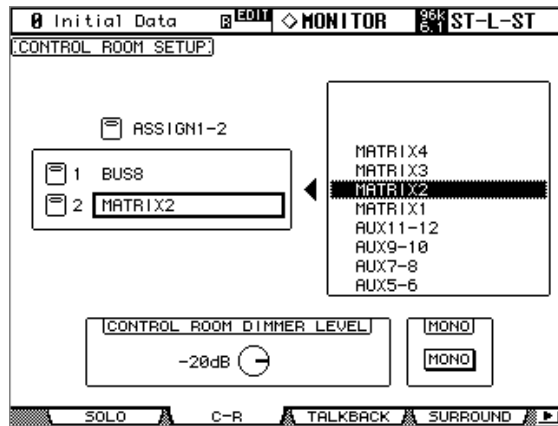

- 2 Use the cursor buttons to select the **ASSIGN** buttons in the left-hand box, and use the **Parameter wheel** to select an **Output Channel** in the right-hand box.

Bus Outs, Aux Sends, or Matrix Sends can be assigned to the [ASSIGN 1] and [ASSIGN 2] buttons.

- 3 Press **[ENTER]** to assign the selected **Output Channel**.

Once assigned, the selected Output Channel appears highlighted in the right-hand box.

The other parameters on this page are as follows.

**CONTROL ROOM DIMMER LEVEL:** This determines the amount of attenuation applied to the Control Room Monitor and Surround Monitor signals by the Dimmer function. Use the cursor buttons to select it, and use the Parameter wheel or INC/DEC buttons to set it from.

**MONO:** This button, which works in unison with the CONTROL ROOM [MONO] button, can be used to switch the Control Room Monitor signal into mono.

## Studio Monitoring

The DM2000 features dedicated outputs, source selection, and level control.

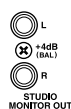

The Studio Monitor signal is output by the STUDIO MONITOR OUT +4 dB (BAL) 1/4-inch TRS phone jacks.

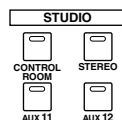

The Studio Monitor signal source is selected by using the STUDIO buttons.

**[CONTROL ROOM]:** Selects the Control Room Monitor.

**[STEREO]:** Selects the Stereo Out.

**[AUX 11]:** Selects Aux Send #11.

**[AUX 12]:** Selects Aux Send #12.



The level of the Studio Monitor signal can be set by using the STUDIO LEVEL control.

## Surround Monitoring

The DM2000 features comprehensive surround monitoring functions, including a pink noise generator for speaker setup, Bass Management, and down mixing.

The Surround Monitor signal source is selected by using the SURROUND buttons. The [BUS] button selects the Bus Outs as the source. The [ASSIGN 1] and [ASSIGN 2] buttons select the Inputs of the Slots specified on the Surround Monitor page as the source. Surround mixes from up to six multitrack recorders can be monitored by patching Slot Inputs to Surround Monitor Channels (see page 163) with the [ASSIGN 1] and [ASSIGN 2] buttons. The level of the Surround Monitor can be set by using the SURROUND MONITOR LEVEL control.

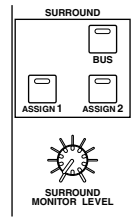

Surround monitor speakers can be aligned by using the individual Attenuator and Delay parameters on each Surround Monitor Channel. In addition to the standard Ls and Rs speakers, the DM2000 supports Ls2 and Rs2 speakers, with independent Attenuator and Delay parameters, for a more diffused surround monitoring environment. See “Configuring Surround Monitoring” on page 161 for more information.

Surround Monitor Channels can be patched to Slot Outputs or Omni Outputs. See “Output Patching” on page 79 for more information.

Surround Monitor settings can be stored in the Surround Monitor library, which contains 1 preset memory and 32 user memories. See “Surround Monitor Library” on page 173 for more information.

General surround monitoring is performed on the Surround Monitor page.

- 1 Use the MONITOR [DISPLAY] button to locate the Surround Monitor page.

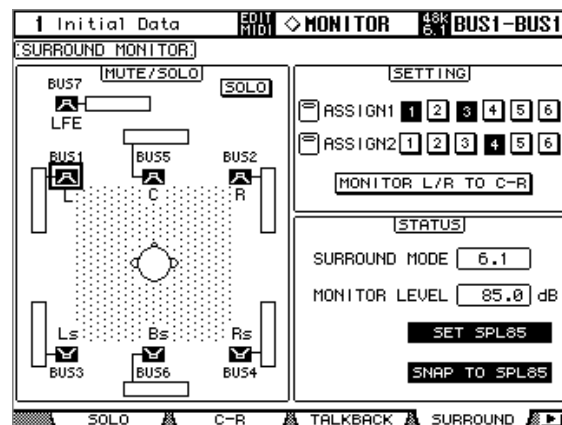

- 2 Use the cursor buttons to select the parameters, and use the Parameter wheel, INC/DEC buttons, and [ENTER] button to set them.

The number of speaker icons and meters shown on the Surround Monitor page depends on the currently selected Surround mode. The meters indicate Bus Out signal levels.

**MUTE/SOLO:** These parameters are used to mute and solo Surround Channels. A Surround Channel is on when its speaker icon is highlighted. Speaker icons can be selected by using the cursor buttons. When SOLO is on, Surround Channels can be soloed by selecting speaker icons and pressing [ENTER].

**SETTING:** These buttons are used to select which Slot’s Inputs are monitored when the SURROUND [ASSIGN 1] and [ASSIGN 2] buttons are pressed. Up to six Slots can be assigned to each ASSIGN button, in which case the signals are mixed. Individual Slot Inputs can be patched to Surround Monitor Channels on the Surround Monitor Patch page (see page 163).



When the MONITOR L/R to C-R button is on, the Left and Right Surround Monitor Channels are fed to the Control Room Monitors. This is useful when you want to use the same speakers for Left and Right Surround Monitors and Control Room Monitors.

**STATUS:** SURROUND MODE indicates the currently selected Surround mode, which is set on the Surround Mode page (see page 97). MONITOR LEVEL indicates the volume setting of the SURROUND MONITOR LEVEL control, which can be calibrated to 85 dB SPL, the cinema standard for setting up Surround Channel Monitor speakers. To do this, output pink noise from the built-in Oscillator (see page 161), set the SURROUND MONITOR LEVEL control and the level controls on the Surround Monitor speaker amps so that the total output is 85 dB SPL, then press the SET SPL85 button. The MONITOR LEVEL indication will then display the volume setting relative to 85 dB SPL. Press the SET SPL85 button again to return to the normal volume indication. Press the SNAP TO SPL85 button to reset the SURROUND MONITOR LEVEL control to 85 dB SPL.

## Configuring Surround Monitoring

Surround monitoring, including speaker setup, monitor matrix, Bass Management, and monitor alignment, is configured on the Surround Monitor Setup page.

- 1 Use the MONITOR [DISPLAY] button to locate the Surround Monitor Setup page.

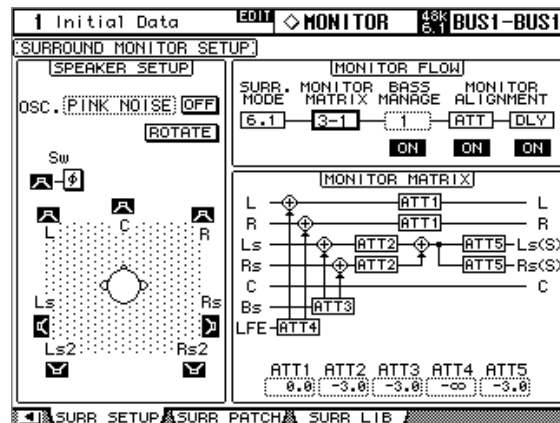

- 2 Use the cursor buttons to select the parameters, and use the Parameter wheel, INC/DEC buttons, and [ENTER] button to set them.

**SPEAKER SETUP:** These parameters are for setting the volume balance of the surround monitor speakers. Select the OSC (Oscillator) parameter and choose from PINK NOISE, 500-2K (pink noise through a 500 Hz to 2 kHz BPF), 1K (1 kHz sinewave), or 50 Hz (50 Hz sinewave). Use the ON/OFF button to turn the Oscillator on and off. When on, the Oscillator outputs a signal at -20 dB to the Surround Channels whose icons are highlighted. You can turn on and off Oscillator output for speakers individually. Speaker icons can be selected by using the cursor buttons. The signal phase of the LFE Channel can be reversed by using the SW phase button. When ROTATE is on, the Oscillator signal is output by each speaker in turn in a clockwise direction (3 second signal, 2 second pause).

**SURR. MODE:** This indicates the currently selected Surround mode, which is set on the Surround Mode page (see page 97).

**MONITOR MATRIX:** This is used to select the Surround Monitor Matrix. In 6.1 Surround mode, you can select 6.1, 5.1, 3-1, or ST. In 5.1 Surround mode, you can select 5.1, 3-1, or ST. In 3-1 Surround mode, you can select 3-1 or ST.

When a down mix Monitor Matrix is selected, you can attenuate signals by using the ATT parameters.

You can use the Surround Monitor settings in Stereo mode, but Monitor Matrix is fixed to ST.

The following screen shows an example in 6.1 Surround mode and 3-1 Monitor Matrix mode.

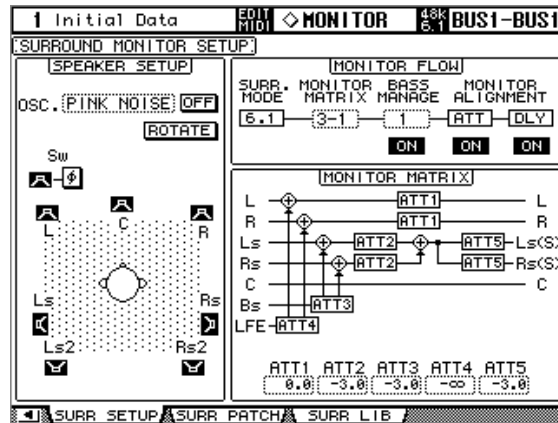

**BASS MANAGEMENT:** You can set the filter and attenuator settings for each Surround Monitor Channel using five preset Bass Management modes.

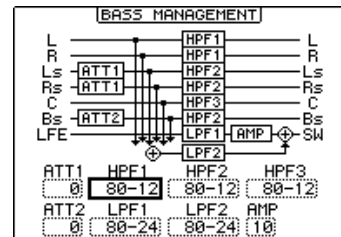

The following presets are available:

Presets		Parameters				
No.	Title	HPF 1, 2, 3	LPF1	LPF2	ATT 1 & 2	AMP
1	DVD Mix w/BS	80-12	80-24	80-24	0	10
2	DVD Author w/BS	80-12	120-42	80-24	0	10
3	Film Mix w/BS	80-12	80-24	80-24	-3	10
4	Film Author w/BS	80-12	120-42	80-24	-3	10
5	Bypass	THRU	THRU	MUTE	0	0

ATT1: Adjusts the level difference between LR and LsRs.

ATT2: Adjusts the level difference between C and Bs.

AMP: Corrects the LFE channel level.

HPF1-3: Cut the low range so that the speakers' supporting frequency ranges will not interfere with the subwoofer signals.

HPF1-2: Cut the high range so that the subwoofer's supporting frequency ranges will not interfere with other speakers' signals.

*Tip: If you select 3-1 Monitor Matrix mode, use Presets 1 or 2 to establish an appropriate monitoring environment.*

You can set the Bass Management parameters in the following ranges:

Parameters	Range
HPF 1, 2, 3	THRU, 80-12, 80-12L, 80-24, 80-24L
LPF1	THRU, 80-24, 80-24L, 120-42
LPF2	THRU, 80-24, 80-24L, MUTE
ATT 1 & 2	0 to -12 dB (1 dB steps)
AMP	0 to +12 dB (1 dB steps)

The HPF 1, 2, 3, and LPF 1 & 2 values indicate a cut-off frequency and a filter response. For example, "80-12" means a cutoff frequency of 80 Hz and a filter response of -12 dB/octave.

"L" means Linkwitz filter. Other filters are Butterworth.

**MONITOR ALIGNMENT ATT & DLY ON/OFF:**

These buttons are used to turn on and off the Monitor Alignment Attenuator and Delay parameters of all Surround speakers. The MONITOR ALIGNMENT diagram and Surround Channel Attenuator and Delay parameters, which are displayed when either of these buttons are selected, allow you to align the surround monitor speakers by attenuating and delaying Surround Channels as necessary. The Attenuator parameters can be set  $-\infty$ ,  $-12$  dB to  $+12$  dB in 0.1 dB steps. The Delay parameters can be set from 0 to 30 msec in 0.02 msec steps.

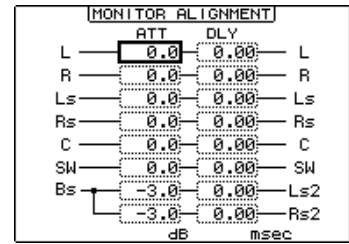

**Patching Slot Inputs to Surround Channels**

Individual Slot Inputs can be patched to Surround Monitor Channels as follows.

- 1 Use the MONITOR [DISPLAY] button to locate the Surround Monitor Patch page.

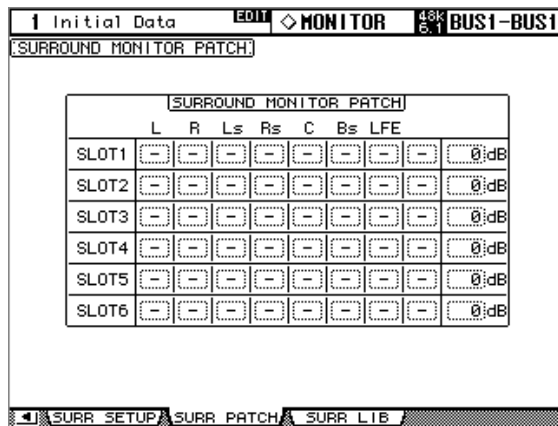

- 2 Use the cursor buttons to select the parameters, and use the Parameter wheel, INC/DEC buttons, and [ENTER] button to set them.

**SLOT/CH:** This patching matrix is used to patch Inputs 1–16 from each of the six Slots to the Surround Monitor Channels. Each Slot Input can be patched to only one Surround Monitor Channel.

**LEVEL:** These parameters are used to set the monitor level of each Slot.

**Using Talkback & Slate**

The Talkback function distributes the Talkback mic signal to the Studio Monitor Outs and any Slot or Omni Outputs specified on the Talkback Setup page.

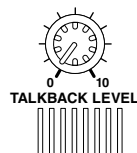

The TALKBACK LEVEL control sets the level of the built-in talkback microphone.



The [TALKBACK] button has two modes of operation: If it's pressed once (i.e., for less than 300 ms), the Talkback function is turned on and remains on when the button is released. This is Latched mode (this mode can be disabled on the Talkback Setup page). If it's pressed and held for longer, the Talkback function is turned on, but turns off when the button is released. This is Unlatched mode. The [TALKBACK] button indicator flashes while the Talkback function is active.

The Slate function distributes the Talkback mic signal to all Bus Outs, Matrix Sends, and the Stereo Out.



The [SLATE] button has two modes of operation: If it's pressed once (i.e., for less than 300 ms), the Slate function is turned on and remains on when the button is released. This is Latched mode. If it's pressed and held for longer, the Slate function is turned on, but turns off when the button is released. This is Unlatched mode. The [SLATE] button indicator flashes while the Slate function is active.

## Talkback Setup

- 1 Use the MONITOR [DISPLAY] button to locate the Talkback Setup page.

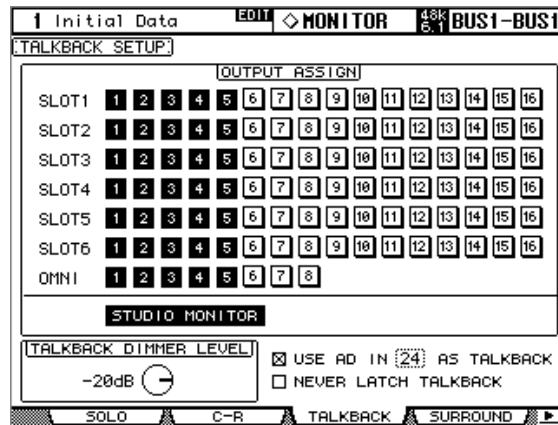

- 2 Use the cursor buttons to select the parameters, and use the Parameter wheel, INC/DEC buttons, and [ENTER] button to set them.

**OUTPUT ASSIGN:** These buttons are used to assign the Talkback mic signal to Slot and Omni Outputs.

**STUDIO MONITOR:** This allows you to select the Talkback mic signal as the Studio Monitor source.

**TALKBACK DIMMER LEVEL:** When the Talkback function is active, this determines the amount of attenuation applied to sound sources assigned to the Studio Monitors and selected for Talkback.

**USE AD IN *x* AS TALKBACK:** This allows you to select an AD Input as the Talkback signal source. Use the check box to turn this option on and off, and use the number parameter to specify the number of the AD Input. The signal from the specified AD Input is mixed with the Talkback mic signal. Turn down the TALKBACK LEVEL if you do not want to use the Talkback mic.

**NEVER LATCH TALKBACK:** This options allows you to disable Talkback latching.

# 14 Libraries

## About the Libraries

The DM2000 features 11 libraries for storing Automix, Effects, Channel, Input Patch, Output Patch, GEQ, Bus to Stereo, Gate, Comp, EQ, and Surround Monitor data.

Library data can be stored to an external MIDI device, such as a MIDI data filer, by using MIDI Bulk Dump (see page 220). It can also be stored to SmartMedia (see page 271).

## General Library Operation

Since most library functions are the same for each library, rather than explain them several times, they're explained only here for conciseness.

### 1 Locate the various library pages as explained in the following sections.

The Input Patch Library page shown below is used here for explanation purposes.

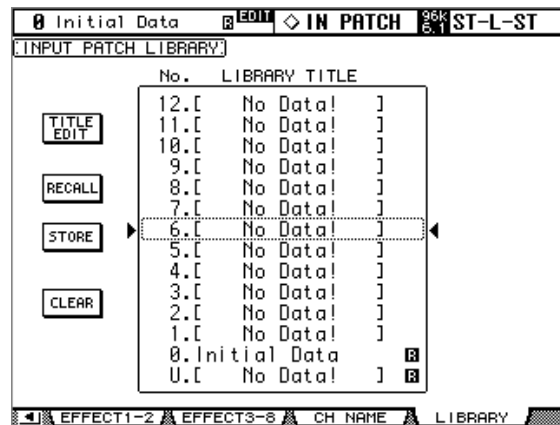

### 2 Use the Parameter wheel or INC/DEC buttons to select the memories.

A memory is selected when it appears inside the dotted box.

### 3 Use the cursor buttons to select the following page buttons.

**TITLE EDIT:** To edit the title of the selected memory, select this and press [ENTER]. When the Title Edit window appears, edit the title, and press OK when you've finished. See "Title Edit Window" on page 54 for more information.

**RECALL:** To recall the contents of the selected memory, select this and press [ENTER]. If the Recall Confirmation preference is on, a confirmation window appears before the contents are recalled.

**STORE:** To store settings to the selected memory, select this and press [ENTER]. When the Title Edit window appears, enter a title, and press OK. See "Title Edit Window" on page 54 for more information. You can stop the Title Edit window from appearing by turning off the Store Confirmation preference on page 275.

**CLEAR:** To delete the contents and title of the selected memory, select this and press [ENTER]. A confirmation window appears before the memory is cleared.

Read-only preset memories have an "R" icon next to their name. You cannot store, clear, or edit the title of these memories.

Empty memories have the title "No Data!" Memory #0 is a read-only memory that you can recall to reset settings to their initial values.

Memory #U is a special read-only memory that allows you to undo and redo memory recall and store operations. After recalling a memory, you can revert to the previously recalled memory by recalling memory #U. After storing a memory, you can revert it to its previous contents by recalling memory #U. You can redo either of these undo operations by recalling memory #U again.

## Channel Library

Input Channel, Bus Out, Aux Send, Matrix Send, and Stereo Out channel settings can be stored in the Channel library, which contains 2 preset memories and 127 user memories. Preset memories are read-only. User memories enable you to store custom settings.

- 1 Use the **DISPLAY ACCESS [VIEW]** button to select the Channel Library page.

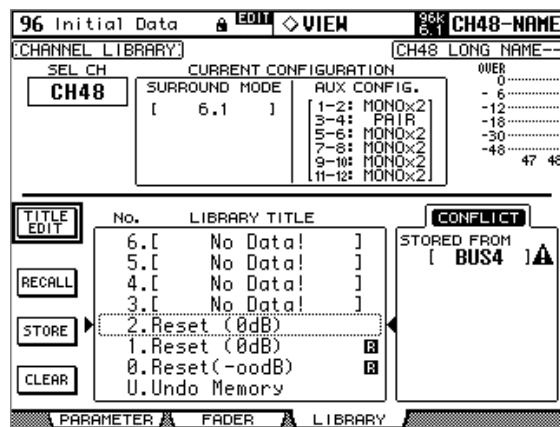

- 2 Use the **LAYER** buttons to select Layers, and the **[SEL]** buttons to select channels.

When storing, the settings of the currently selected channel are stored to the selected memory. When recalling, the settings in the selected memory are applied to the currently selected channel.

Only memories whose contents correspond to the currently selected channel can be recalled. For example, you can recall Input Channel settings to Input Channels, but not to Aux Sends. When the selected memory and currently selected channel don't correspond, a warning triangle and the word "CONFLICT" appear in the STORED FROM box.

Preset memory #0, "Reset(-∞dB)," resets all parameters of the currently selected channel to their initial values and sets the channel level to -∞ dB. Preset memory #1, "Reset (0dB)," also resets all parameters, but sets the channel level to 0 dB (i.e., nominal).

**SEL CH:** This indicates the currently selected channel.

**CURRENT CONFIGURATION:** If the currently selected channel is an Input Channel, Surround mode and Aux configuration information is displayed here.

**Level meters:** These meters indicate the levels of the currently selected Input Channel and its horizontal or vertical partner.

**STORED FROM:** This indicates the channel whose settings were originally stored in the selected memory. If the currently selected channel is an Input channel, Pan mode and Aux pairing information is also displayed.

For details on the Store, Recall, Title Edit, and Clear functions, see "General Library Operation" on page 165.

## Input Patch Library

Input Patch settings can be stored in the Input Patch library, which contains 1 preset memory and 32 user memories. The preset memory is read-only. User memories enable you to store custom settings. See page 77 for information on Input Patch settings.

- 1 Use the **DISPLAY ACCESS [INPUT PATCH]** button to select the **Input Patch Library** page.

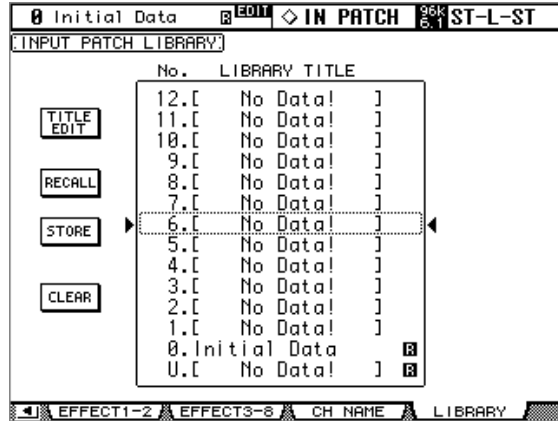

When storing, the current Input Patch settings are stored to the selected memory.

For details on the Store, Recall, Title Edit, and Clear functions, see “General Library Operation” on page 165.

## Output Patch Library

Output Patch settings can be stored in the Output Patch library, which contains 1 preset memory and 32 user memories. The preset memory is read-only. User memories enable you to store custom settings. See page 79 for information on Output Patch settings.

- 1 Use the **DISPLAY ACCESS [OUTPUT PATCH]** button to select the **Output Patch Library** page.

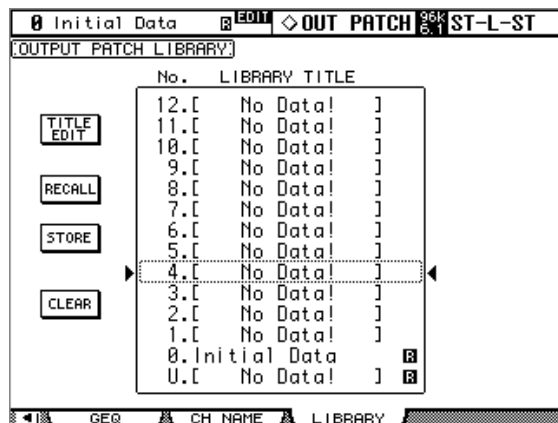

When storing, the current Output Patch settings are stored to the selected memory.

For details on the Store, Recall, Title Edit, and Clear functions, see “General Library Operation” on page 165.

## GEQ Library

GEQ (Graphic Equalizer) settings can be stored in the GEQ library, which contains 1 preset memory and 128 user memories. The preset memory is read-only. User memories enable you to store custom settings. See page 183 for information on using the GEQs.

- 1 Use the **EFFECTS/PLUG-INS [DISPLAY]** button to select the **Graphic Equalizer Library** page.

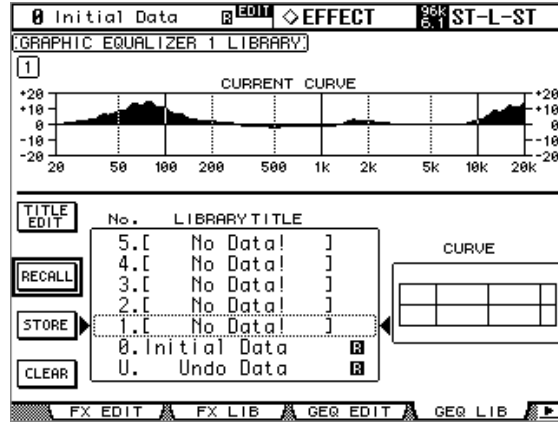

- 2 Press the **EFFECTS/PLUG-INS [GRAPHIC EQUALIZERS]** button, and use the **EFFECTS/PLUG-INS [1–6]** buttons to select the GEQs.

When storing, the settings of the currently selected GEQ, indicated in the upper-left corner, are stored to the selected memory.

**CURRENT CURVE:** This is the response curve of the currently selected GEQ.

**CURVE:** This displays the response curve in the currently selected memory.

For details on the Store, Recall, Title Edit, and Clear functions, see “General Library Operation” on page 165.

## Effects Library

Effects settings can be stored in the Effects library, which contains 61 preset memories and 67 user memories. Preset memories are read-only. User memories enable you to store custom settings. See page 174 for information on using the Effects.

- 1 Use the **EFFECTS/PLUG-INS [DISPLAY]** button to select the **Effect Library** page.

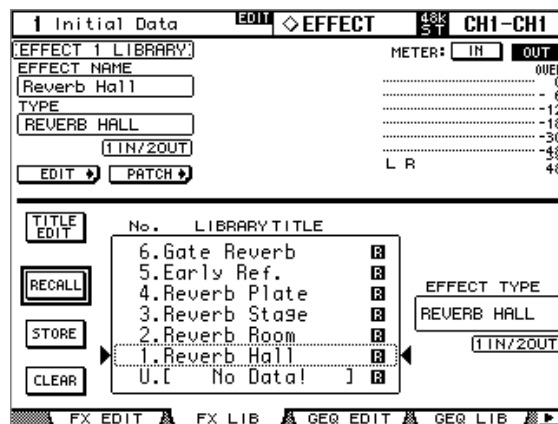



**2 Press the EFFECTS/PLUG-INS [INTERNAL EFFECTS] button, and use the EFFECTS/PLUG-INS [1–8] buttons to select the internal effects processors.**

When storing, the settings of the currently selected internal effects processor, indicated in the upper-left corner, are stored to the selected memory.

**EFFECT NAME:** This is the name of the previously recalled Effects memory.

**TYPE:** This is the effects type used in the previously recalled Effects memory. Its I/O configuration is shown below this.

**EDIT:** Pressing this button, then the [ENTER] button, displays the Effects Edit page, which enables you to adjust the Effects parameters. See “Editing Effects” on page 177 for more information.

**PATCH:** Pressing this button, then the [ENTER] button, displays the Effects Input Patch page, which enables you to patch internal Effects processor inputs and outputs. See “Patching Effects Inputs and Outputs” on page 78 for more information.

**Level meters:** These meters indicate the input and output levels of the currently selected Effects processor. Use the IN and OUT buttons to switch between input level and output level. There are eight meters for Effects processors #1 and #2, and two meters for Effects processors #3 through #8.

**EFFECT TYPE:** This is the effects type in the selected memory. Its I/O configuration is shown below this.

For details on the Store, Recall, Title Edit, and Clear functions, see “General Library Operation” on page 165.

## Bus to Stereo Library

Bus to Stereo settings can be stored in the Bus to Stereo library, which contains 1 preset memory and 32 user memories. The preset memory is read-only. User memories enable you to store custom settings. See page 109 for information on Bus to Stereo routing.

**1 Use the ROUTING [DISPLAY] button to select the Bus to Stereo Library page.**

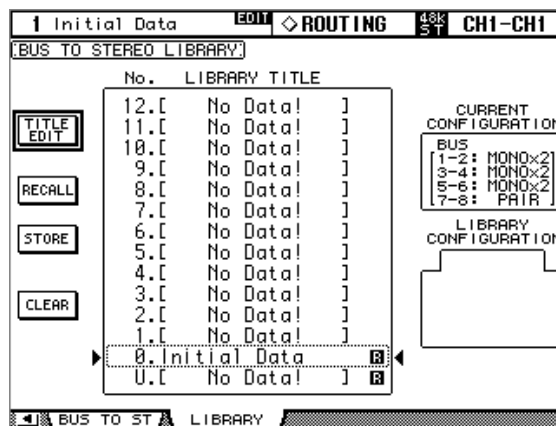

When storing, the current Bus Out to Stereo Out settings are stored to the selected memory.

**CURRENT CONFIGURATION:** Bus Out pairing information for the current configuration is displayed here.

**LIBRARY CONFIGURATION:** Bus Out pairing information for the configuration stored in the currently selected memory is displayed here.

If the Bus Out pairing configuration does not match the current configuration, the word “CONFLICT” will appear in the LIBRARY CONFIGURATION box. In this case, if you recall such a memory, the DM2000 will apply the current Bus Out pairing configuration and related parameter settings to the recalled memory settings.

For details on the Store, Recall, Title Edit, and Clear functions, see “General Library Operation” on page 165.

## Gate Library

Input Channel Gate settings can be stored in the Gate library, which contains 4 preset memories and 124 user memories. Preset memories are read-only. User memories enable you to store custom settings. See page 85 for information on gating Input Channels.

- 1 Use the **DYNAMICS [DISPLAY]** button to select the Gate Library page.

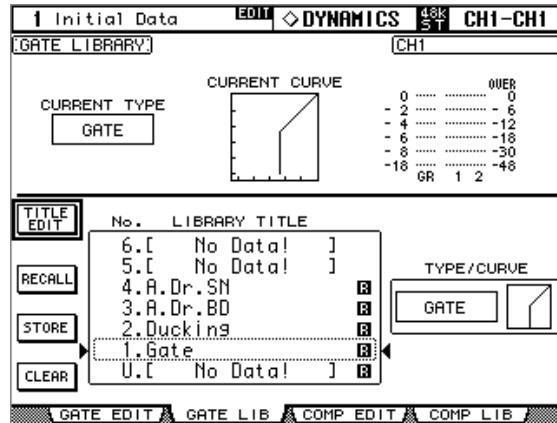

- 2 Use the **LAYER** buttons to select the Input Channel Layers, and the **[SEL]** buttons to select Input Channels.

When storing, the Gate settings of the currently selected Input Channel, indicated in the upper-right corner, are stored to the selected memory. When recalling, the Gate settings in the selected memory are applied to the currently selected Input Channel.

**CURRENT TYPE:** This indicates the current Gate type of the currently selected channel.

**CURRENT CURVE:** This is the Gate curve of the currently selected channel.

**GR meters:** These meters indicate the amount of gain reduction being applied by the Gate, and the levels of the currently selected channel and its adjacent channel. If Pair mode for the currently selected channel is set to Vertical, the level of its counterpart on the adjacent Layer is displayed.

**TYPE/CURVE:** The type (Gate or Ducking) and curve of the currently selected memory is displayed to the right of the memory list.

For details on the Store, Recall, Title Edit, and Clear functions, see “General Library Operation” on page 165.

## Comp Library

Comp settings can be stored in the Comp library, which contains 36 preset memories and 92 user memories. Preset memories are read-only. User memories enable you to store custom settings. See page 137 for information on the Comps.

- 1 Use the **DYNAMICS [DISPLAY]** button to select the Comp Library page.

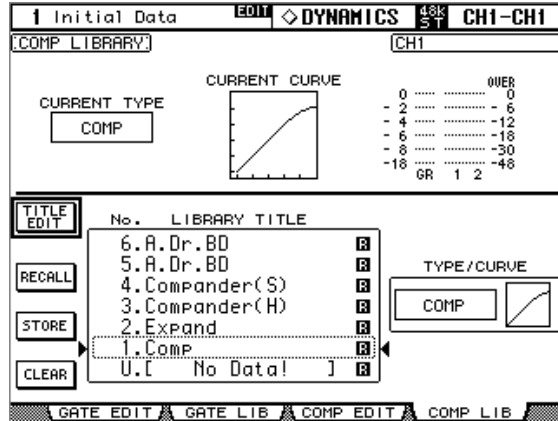

- 2 Use the **LAYER** buttons to select Layers, and the **[SEL]** buttons to select channels.

When storing, the Comp settings of the currently selected channel, indicated in the upper-right corner, are stored to the selected memory. When recalling, the Comp settings in the selected memory are applied to the currently selected channel.

**CURRENT TYPE:** This indicates the current Comp type of the currently selected channel.

**CURRENT CURVE:** This is the Comp curve of the currently selected channel.

**GR meters:** These meters indicate the amount of gain reduction being applied by the Comp, and the levels of the currently selected channel and its adjacent channel. If Pair mode for the currently selected channel is set to Vertical, the level of its counterpart on the adjacent Layer is displayed.

**TYPE/CURVE:** The type (Compressor, Expander, Comander Hard, Comander Soft) and curve of the currently selected memory is displayed to the right of the memory list.

For details on the Store, Recall, Title Edit, and Clear functions, see “General Library Operation” on page 165.

## EQ Library

Input Channel, Bus Out, Aux Send, Matrix Send, and Stereo Out EQ settings can be stored in the EQ library, which contains 40 preset memories and 160 user memories. Preset memories are read-only. User memories enable you to store custom settings. See page 131 for information on EQ'ing.

- 1 Use the **EQUALIZER [DISPLAY]** button to select the EQ Library page.

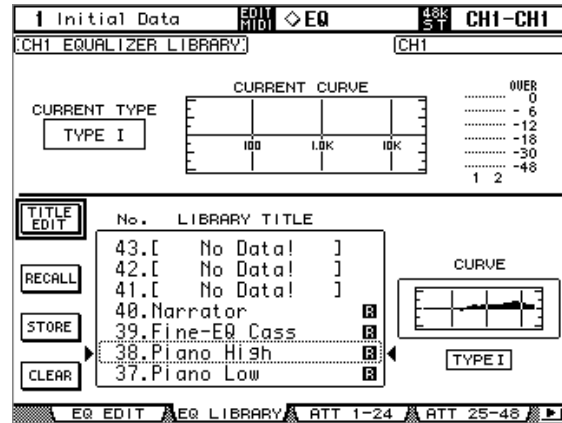

- 2 Use the **LAYER** buttons to select Layers, and the **[SEL]** buttons to select channels.

When storing, the EQ settings of the currently selected channel, indicated in the upper-left and right corners, are stored to the selected memory. When recalling, the EQ settings in the selected memory are applied to the currently selected channel.

**CURRENT TYPE:** This indicates the current EQ type (TYPE I or TYPE II) for the currently selected channel.

**CURRENT CURVE:** This is the EQ curve of the currently selected channel.

**Level meters:** These meters indicate the levels of the currently selected Input Channel and its horizontal or vertical partner.

**CURVE:** This displays the EQ curve in the currently selected memory.

For details on the Store, Recall, Title Edit, and Clear functions, see “General Library Operation” on page 165.

## Automix Library

Up to 16 Automixes can be stored in the Automix library. See page 193 for information on using Automix.

- 1 Use the **AUTOMIX [DISPLAY]** button to select the Automix Memory page.

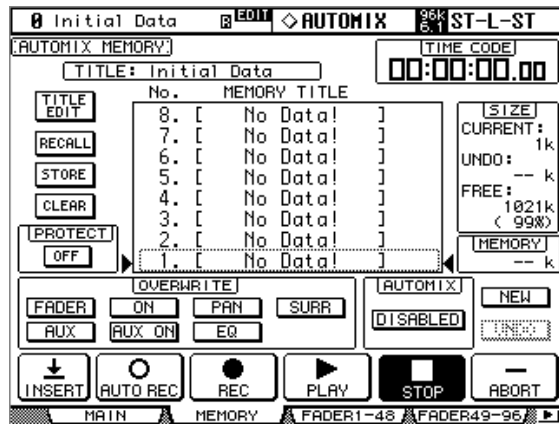

When storing, the current Automix is stored to the selected memory.

**TITLE:** This is the title of the current Automix.

**CURRENT:** This is the size of the current Automix.

**UNDO:** This is the size of the Automix data in the current Undo buffer.

**FREE:** This is the amount of free memory for storing the current Automix.

**MEMORY:** This is the size of the selected Automix memory.

**PROTECT:** To protect the contents of the selected memory, select this and press [ENTER]. A padlock icon appears next to the titles of memories that are write-protected. Automixes cannot be stored to write-protected memories.

For details on the Store, Recall, Title Edit, and Clear functions, see “General Library Operation” on page 165.

## Surround Monitor Library

Surround Monitor settings can be stored in the Surround Monitor library, which contains 1 preset memory and 32 user memories. The preset memory is read-only. User memories enable you to store custom settings. See page 160 for information on Surround Monitoring.

- 1 Use the **MONITOR [DISPLAY]** button to select the Surround Monitor Library page.

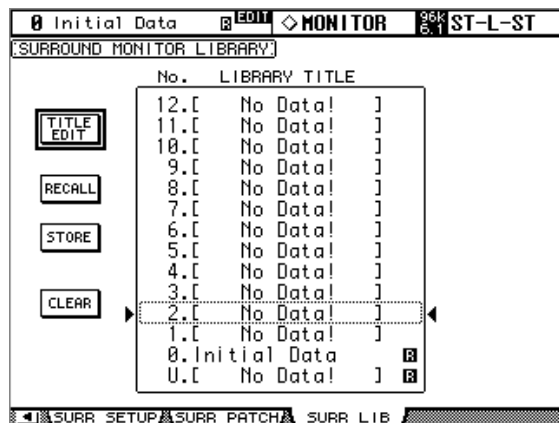

When storing, the current Surround Monitor settings are stored to the selected memory.

For details on the Store, Recall, Title Edit, and Clear functions, see “General Library Operation” on page 165.

# 15 Internal Effects, Plug-Ins & GEQs

## About the Effects

The DM2000 features eight internal multi-effects processors, offering a whole host of effects types, including reverbs, delays, modulation-based effects, combination effects, and multi-channel effects designed especially for use with surround sound.

Effects processors 3–8 feature assignable stereo inputs and outputs. Processors #1 and #2, which are intended for use with the multichannel surround effects, feature eight assignable inputs and outputs. Processor inputs and outputs can be patched to various sources, including the inputs and outputs of other Effects processors, allowing you to chain processors together in series. (The only outputs available for patching in series are effects processor outputs OUT1 and OUT2.)

The input and output signal levels of the currently selected Effects processor can be metered on the Effects Edit page and the Effects Library page. The input and output signal levels of all Effects processors can be metered on the Meter pages. See “Metering” on page 127 for more information.

Effects settings can be stored in the Effects library, which contains 61 preset memories and 67 user memories. See “Effects Library” on page 168 for more information.

## Patching Effects Processors

Effects processor inputs can be fed from the Aux Sends, Input and Output Channel Insert Outs, or the outputs of another Effects processor. See “Patching Effects Inputs and Outputs” on page 78 for more information.

Effects processor outputs can be patched to the Input Channels, Input and Output Channel Insert Ins, or the inputs of another Effects processor. See “Output Patching” on page 79 for more information.

## Preset Effects & Types

The following tables list the preset effects and types. See page 310 for detailed parameter information.

### Reverbs

#	Preset Name	Type	Description
1	<b>Reverb Hall</b>	REVERB HALL	Concert hall reverberation simulation with gate
2	<b>Reverb Room</b>	REVERB ROOM	Room reverberation simulation with gate
3	<b>Reverb Stage</b>	REVERB STAGE	Reverb designed for vocals, with gate
4	<b>Reverb Plate</b>	REVERB PLATE	Plate reverb simulation with gate
5	<b>Early Ref.</b>	EARLY REF.	Early reflections without the subsequent reverb
6	<b>Gate Reverb</b>	GATE REVERB	Gated early reflections
7	<b>Reverse Gate</b>	REVERSE GATE	Gated reverse early reflections

### Delays

#	Preset Name	Type	Description
8	<b>Mono Delay</b>	MONO DELAY	Simple mono delay
9	<b>Stereo Delay</b>	STEREO DELAY	Simple stereo delay
10	<b>Mod.delay</b>	MOD.DELAY	Simple repeat delay with modulation
11	<b>Delay LCR</b>	DELAY LCR	3-tap (left, center, right) delay
12	<b>Echo</b>	ECHO	Stereo delay with crossed left/right feedback

## Modulation-based Effects

#	Preset Name	Type	Description
13	Chorus	CHORUS	Chorus
14	Flange	FLANGE	Flanger
15	Symphonic	SYMPHONIC	Proprietary Yamaha effect that produces a richer and more complex modulation than normal chorus
16	Phaser	PHASER	16-stage stereo phase shifter
17	Auto Pan	AUTO PAN	Auto-panner
18	Tremolo	TREMOLO	Tremolo
19	HQ.Pitch	HQ.PITCH	Mono pitch shifter, producing stable results
20	Dual Pitch	DUAL PITCH	Stereo pitch shifter
21	Rotary	ROTARY	Rotary speaker simulation
22	Ring Mod.	RING MOD.	Ring modulator
23	Mod.Filter	MOD.FILTER	Modulated filter

## Guitar Effects

#	Preset Name	Type	Description
24	Distortion	DISTORTION	Distortion
25	Amp Simulate	AMP SIMULATE	Guitar amp simulation

## Dynamic Effects

#	Preset Name	Type	Description
26	Dyna.Filter	DYNA.FILTER	Dynamically controlled filter
27	Dyna.Flange	DYNA.FLANGE	Dynamically controlled flanger
28	Dyna.Phaser	DYNA.PHASER	Dynamically controlled phase shifter

## Combination Effects

#	Preset Name	Type	Description
29	Rev+Chorus	REV+CHORUS	Reverb and chorus in parallel
30	Rev->Chorus	REV->CHORUS	Reverb and chorus in series
31	Rev+Flange	REV+FLANGE	Reverb and flanger in parallel
32	Rev->Flange	REV->FLANGE	Reverb and flanger in series
33	Rev+Sympho.	REV+SYMPHO.	Reverb and symphonic in parallel
34	Rev->Sympho.	REV->SYMPHO.	Reverb and symphonic in series
35	Rev->Pan	REV->PAN	Reverb and auto-pan in series
36	Delay+ER.	DELAY+ER.	Delay and early reflections in parallel
37	Delay->ER.	DELAY->ER.	Delay and early reflections in series
38	Delay+Rev	DELAY+REV	Delay and reverb in parallel
39	Delay->Rev	DELAY->REV	Delay and reverb in series
40	Dist->Delay	DIST->DELAY	Distortion and delay in series

## Others

#	Preset Name	Type	Description
41	<b>Multi.Filter</b>	MULTI.FILTER	3-band parallel filter (24 dB/octave)
42	<b>Freeze</b>	FREEZE	Simple sampler
43	<b>Stereo Reverb</b>	ST REVERB	Stereo reverb
44 <sup>1</sup>	<b>Reverb 5.1</b>	REVERB 5.1 <sup>2</sup>	6-channel reverb for 5.1 surround
45 <sup>1</sup>	<b>Octa Reverb</b>	OCTA REVERB <sup>2</sup>	8-channel reverb for 7.1 surround
46 <sup>1</sup>	<b>Auto Pan 5.1</b>	AUTO PAN 5.1	6-channel auto pan for 5.1 surround
47 <sup>1</sup>	<b>Chorus 5.1</b>	CHORUS 5.1	6-channel chorus for 5.1 surround
48 <sup>1</sup>	<b>Flange 5.1</b>	FLANGE 5.1	6-channel flanger for 5.1 surround
49 <sup>1</sup>	<b>Sympho. 5.1</b>	SYMPHO. 5.1	6-channel symphonic effect for 5.1 surround
50	<b>M. Band Dyna.</b>	M. BAND DYNA.	Multi-band dynamics processor
51 <sup>1</sup>	<b>Comp 5.1</b>	COMP 5.1 <sup>2</sup>	Multi-band compressor for 5.1 surround
52 <sup>1</sup>	<b>Compand 5.1</b>	COMPAND 5.1 <sup>2</sup>	Multi-band compander for 5.1 surround
53 <sup>3</sup>	<b>Comp276</b>	—	—
54 <sup>3</sup>	<b>Comp276S</b>	—	—
55 <sup>3</sup>	<b>Comp260</b>	—	—
56 <sup>3</sup>	<b>Comp260S</b>	—	—
57 <sup>3</sup>	<b>Equalizer601</b>	—	—
58 <sup>3</sup>	<b>OpenDeck</b>	—	—
59 <sup>3</sup>	<b>REV-X Hall</b>	—	—
60 <sup>3</sup>	<b>REV-X Room</b>	—	—
61 <sup>3</sup>	<b>REV-X Plate</b>	—	—

1. These effects can be recalled only to Effects processors #1 and #2.
2. Since these effects types require four DSPs, the total number of Effects processors is reduced by three when one of these types is used. For example, if REVERB 5.1 is used with Effects processor #1, only processors 2–5 are available. And if, for example, REVERB 5.1 is used with both Effects processor #1 and #2, then processors 3–8 are not available.
3. Preset numbers are reserved for Add-On Effects. Effects that are not installed appear in gray and are unavailable for use. See “Adding Optional Add-On Effects” on page 178 for more information on Add-On Effects.



## Editing Effects

The internal effects processors can be edited as follows.

- 1 Press the EFFECTS/PLUG INS [INTERNAL EFFECTS] button.
- 2 Use the EFFECTS/PLUG INS [1–8] buttons to select the internal effects processors.
- 3 Use the EFFECTS/PLUG INS [DISPLAY] button to locate the Effects Library page, and recall a preset effects memory that contains the effects type that you want.  
See “Effects Library” on page 168 for more information.
- 4 Use the EFFECTS/PLUG INS [DISPLAY] button to locate the Effects Edit page.

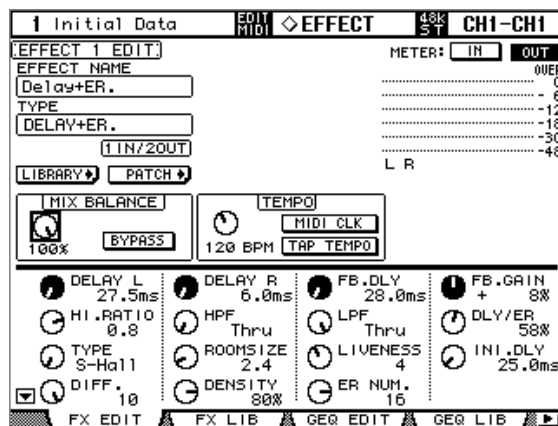

The available effects parameters depends on the effects type currently selected. See page 310 for detailed parameter information.

- 5 Use the cursor buttons to select the parameters, and use the Parameter wheel, INC/DEC buttons, or [ENTER] button to set them.

**EFFECT NAME:** This is the name of the currently-recalled Effects memory.

**TYPE:** This is the effects type used in the currently-recalled Effects memory. Its I/O configuration is shown below this.

**LIBRARY:** Select the LIBRARY button, then press [ENTER] to display the Library page for the selected effects processor. See “Effects Library” on page 168 for more information.

**PATCH:** Select the PATCH button, then press [ENTER] to display the Effects Input/Output Patch page, which enables you to patch internal Effects processor inputs and outputs. See “Patching Effects Inputs and Outputs” on page 78 for more information.

**MIX BALANCE:** This is used to set the balance between the wet and dry signals. When set to 0%, only the dry signal is heard. When set to 100%, only the wet signal is heard.

**BYPASS:** This button is used to bypass the currently selected Effects processor.

**TEMPO:** The TEMPO section displays TEMPO parameters for delay and modulation-based effects. These TEMPO parameters calculate and set the delay time for delay effects, or the modulation frequency for modulation effects, relative to the specified tempo and note duration. Use these parameters along with the SYNC and NOTE parameters.

When you turn on the SYNC parameter, the DM2000 recalculates the delay time or modulation frequency based on the TEMPO parameter value (tempo) and the NOTE parameter value (note). For example, if the TEMPO parameter is set to 120BPM and the NOTE parameter is set to an eighth note, turning on the SYNC parameter sets the delay time to 250msec and the modulation frequency to 0.25Hz.

*Tip:*

- If you turn on the SYNC parameter and edit the TEMPO or NOTE parameter, the DM2000 recalculates the delay time or modulation frequency.
- If you turn on the SYNC parameter and edit the delay time or modulation frequency, the NOTE parameter value changes based on the TEMPO parameter setting.
- See “Effects and tempo synchronization” on page 331 for more information on the tempo sync parameters.

**Level meters:** The Level meters indicate the input and output levels of the currently selected Effects processor. Select the IN or OUT button to display input or output levels respectively. There are eight output meters for Effects processors 1 and 2, and two output meters for Effects processors 3 through 8.

Effects parameters can also be adjusted by using Parameter controls 1–4. Use the Parameter Up/Down buttons to select the rows of parameters. The parameters in the currently selected row appear highlighted. Up to 16 parameters can be displayed at a time, and if more are available, an up or down arrow is displayed.

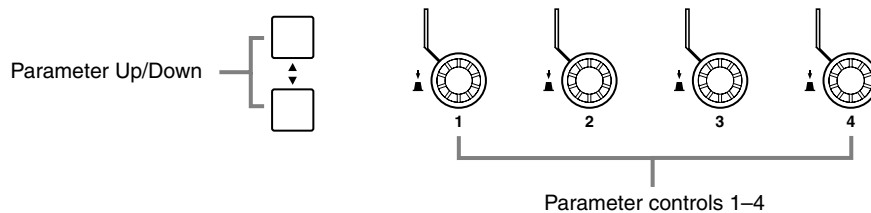

When a Y56K card effect, or an internal effects processor is inserted in the currently selected channel, when the EFFECTS/PLUG-INS [CHANNEL INSERTS] button is pressed, the corresponding EFFECTS/PLUG-INS [1–8] button indicator flashes, and the corresponding Effects, or Plug-In edit page appears. If it’s a Y56K card that’s inserted, the [PLUG-INS] button indicator also flashes. If it’s an internal effects processor, the [INTERNAL EFFECTS] button indicator also flashes. This applies only to effects that are inserted into channels. If there’s nothing inserted in the currently selected channel, a message appears.

## Adding Optional Add-On Effects

Installing an optional Add-On Effect package enables you to expand the internal Effects processors. You can use installed Add-On Effects as preset effects #53 and up. Edited settings can be stored in user memories #68 and up. Refer to the installation guide included in your Add-On Effect package for information on installing the effects.

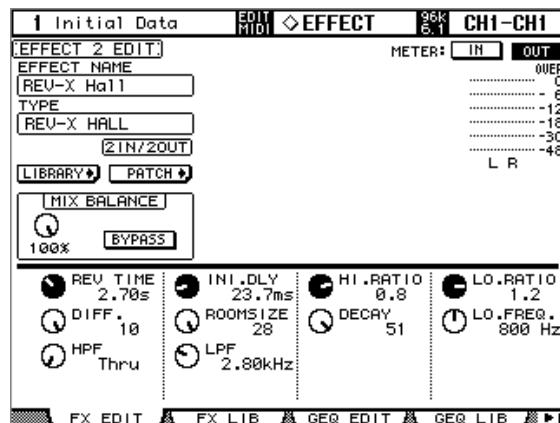

As of January 2004, the following Add-On Effect packages are available:

- AE011 Channel Strip Package
- AE021 Master Strip Package
- AE031 Reverb Package

Additional packages will be released in the future. Visit the Yamaha web site for the latest information:

<http://www.yamahaproaudio.com/>

## About Plug-Ins

There are two types of Plug-Ins: Waves Plug-Ins and User Defined Plug-Ins. Waves Plug-Ins are available on Y56K cards, which need to be installed in the DM2000's mini YGDAI Slots (Slots 4–6 only). See your Yamaha dealer for details. User Defined Plug-Ins can be used to control up to 32 user definable parameters via MIDI Control Change or Parameter Change messages on an external MIDI device, such as an external effects processor. Plug-In parameters can be controlled by using the four Parameter controls below the display. Plug-In parameter settings are stored in Scenes, for snapshot-style automation.

When installing Y56K cards, mini YGDAI Slots 4–6 correspond to Plug-Ins 4–6, so if you install, for example, a Y56K card in Slot #4, it's automatically configured as Plug-In #4. DM2000 signals are patched through to the Y56K card's effect chains just like any other signal is patched through to a Slot Input or Output. Slot Outputs (i.e., effect chain inputs) can be fed from the Bus Outs, Aux Sends, Matrix Sends, Stereo Out, or the Input and Output Channel Insert Outs. Slot Inputs (i.e., effect chain outputs) can be fed to the Input Channels, or the Input and Output Channel Insert Ins. See "Input & Output Patching" on page 77.

Settings for Y56K cards are stored in memory on the card when you store a Scene, and recalled automatically during Scene recall. Please note, however, that these settings cannot be stored in DM2000 Scenes. Therefore, the cards do not support Scene memory global paste, sort, and other scene related functions.

*Note: Y56K cards use Scenes #1–#96. If you store or recall Scenes #97 and up, the Y56K card settings will not reflect the Scenes. (A warning message will appear.)*

## Configuring Plug-Ins

Plug-Ins can be configured as follows.

If you've installed a Y56K card into one of the Slots, the DM2000 configures itself automatically and no further configuration settings are required.

- 1 Press the EFFECTS/PLUG INS [PLUG-INS] button.
- 2 Use the EFFECTS/PLUG INS [DISPLAY] button to locate the Plug-In Setup page.

TARGET	TITLE	PORT
PLUG-IN1	USER DEFINED <REV500 PARAMETER>	USB {2}
PLUG-IN2	USER DEFINED <ProR3 REV PARAM >	USB {3}
PLUG-IN3	USER DEFINED <ProR3 REV PARAM >	USB {4}
PLUG-IN4	NO ASSIGN	NO ASSIGN
PLUG-IN5	NO ASSIGN	NO ASSIGN
PLUG-IN6	NO ASSIGN	NO ASSIGN
PLUG-IN7	NO ASSIGN	NO ASSIGN
PLUG-IN8	NO ASSIGN	NO ASSIGN

- 3 Use the cursor buttons to select the parameters, and use the Parameter wheel, INC/DEC buttons, and [ENTER] button to set them.

**TARGET:** These are used to assign a target to each of the eight Plug-Ins. Parameters for the specified target appear on the Plug-In Edit page when that Plug-In is selected by using the EFFECTS PLUG-INS [1–8] buttons. In addition to using the cursor buttons, Plug-Ins can also be selected on this page by using the EFFECTS PLUG-INS [1–8] buttons.

**TITLE:** If a Y56K card is installed, its name is displayed here. If the target is set to USER DEFINED, the specified title of the bank currently selected on the Plug-In Edit page is displayed.

**PORT:** If a Y56K card is installed, its Slot number is displayed here. If the target is set to USER DEFINED, you can specify the Plug-Ins MIDI port as MIDI, SERIAL 1–8, USB 1–8, or SLOT1 1–8. Plug-In MIDI Ports can also be set on the MIDI/To Host Setup page. See “MIDI I/O” on page 215 for more information.

Plug-In Setup settings are stored in the Setup data. See “Saving DM2000 Data to SmartMedia” on page 271 for more information.

## Editing Plug-Ins

Plug-Ins can be edited as follows. The settings of Waves Plug-Ins and User Defined Plug-In banks can be stored to an external MIDI device, such as a MIDI data filer, by using MIDI Bulk Dump (see page 220), or stored to SmartMedia (see page 271).

If you've installed a Y56K card into one of the Slots, display pages especially for the Waves card are displayed when the corresponding Plug-In is selected. See the Waves documentation for more information. The following explanation applies only to User Defined Plug-Ins.

- 1 Press the EFFECTS/PLUG INS [PLUG-INS] button.
- 2 Use the EFFECTS/PLUG INS [1–8] buttons to select the Plug-Ins.
- 3 Use the EFFECTS/PLUG INS [DISPLAY] button to locate the Plug-In Edit page.

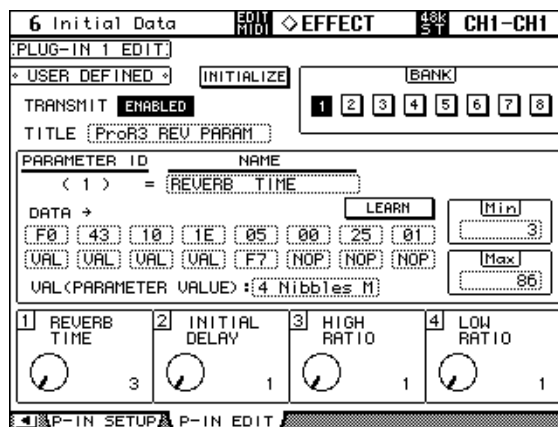

- 4 Use the cursor buttons to select the parameters, and use the Parameter wheel, INC/DEC buttons, and [ENTER] button to set them.

**TRANSMIT:** This enables and disables MIDI data transmission for the currently selected Plug-In.

**INITIALIZE:** This initializes the settings of the currently selected bank.

**BANK:** These buttons are used to select the parameter banks of the currently selected Plug-In. Up to four parameter settings can be stored in each bank, making a total of 32 parameters per Plug-In.

**TITLE:** This is used to enter a title (up to 16 characters long) for each bank. To enter a title for the currently selected bank, select this and press [ENTER]. When the Title Edit window appears, enter a title, and press OK when you've finished. See "Title Edit Window" on page 54 for more information.

**PARAMETER ID/NAME:** This is used to select the four rotary controls at the bottom of the Plug-In Edit page for editing, and to enter a name (up to 16 characters long) for each control. Use the Parameter wheel or INC/DEC buttons to select a Parameter ID from 1–4, and then press [ENTER]. When the Title Edit window appears, enter a title, and press OK when you've finished. See "Title Edit Window" on page 54 for more information.

**DATA:** This is used to specify the MIDI message (up to 16 bytes) to be transmitted when each parameter control is adjusted. Use the PARAMETER ID/NAME parameter to select a Parameter ID from 1–4, and then edit as necessary. Data values can be set in hex from 00 to FF. The VAL setting is the value of the parameter control. The END setting specifies the end of the data. NOP means no data is transmitted.

**LEARN:** This button is used to turn on and off the Learn function, which can be used to learn what MIDI messages are transmitted by external MIDI devices when their controls or parameters are adjusted. When on, received MIDI messages are displayed by the DATA parameter. Only the first 16 bytes of data, starting with a Status bit, are displayed.

**MIN/MAX:** These parameters determine the minimum and maximum values of the MIDI data transmitted when each parameter control is adjusted. Use the PARAMETER ID/NAME parameter to select a Parameter ID from 1–4, and then edit as necessary.

**VAL:** This is used to select the format for converting parameter control values to the DATA parameter’s VAL setting. It applies to the currently selected bank. The available options are listed in the following table.

VAL	Description	VAL count
One byte	Transmit the lower 7 bits of the parameter value as 1 word	Up to one VAL
MSB/LSB	Transmit the lower 14 bits of the parameter value in 7-bit units starting from the upper byte	Up to two VAL’s
LSB/MSB	Transmit the lower 14 bits of the parameter value in 7-bit units starting from the lower byte	Up to two VAL’s
2 Nibbles M	Transmit the lower 8 bits of the parameter value in 4-bit units, consecutively from the highest data	Up to two VAL’s
3 Nibbles M	Transmit the lower 12 bits of the parameter value in 4-bit units, consecutively from the highest data	Up to three VAL’s
4 Nibbles M	Transmit the parameter value in 16 bit units, consecutively from the highest data	Up to four VAL’s
2 Nibbles L	Transmit the lower 8 bits of the parameter value in 4-bit units, consecutively from the lowest data	Up to two VAL’s
3 Nibbles L	Transmit the lower 12 bits of the parameter value in 4-bit units, consecutively from the lowest data	Up to three VAL’s
4 Nibbles L	Transmit the parameter value in 16-bit units, consecutively from the lowest data	Up to four VAL’s

When the controls at the bottom of the Plug-In Edit page are operated, the specified MIDI data, along with the value of the parameter control, is transmitted.

Plug-In parameters can also be adjusted by using Parameter controls 1–4, which correspond to the four parameters shown at the bottom of the Plug-In Edit page.

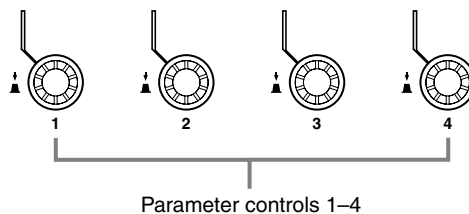

When a Y56K card effect, or an internal effects processor is inserted in the currently selected channel, when the EFFECTS/PLUG-INS [CHANNEL INSERTS] button is pressed, the corresponding EFFECTS/PLUG-INS [1–8] button indicator flashes, and the corresponding Effects, or Plug-In edit page appears. If it’s a Y56K card that’s inserted, the [PLUG-INS] button indicator also flashes. If it’s an internal effects processor, the [INTERNAL EFFECTS] button indicator also flashes. This applies only to effects that are inserted into channels. If there’s nothing inserted in the currently selected channel, a message appears.

The parameter settings, and the target and bank for each Plug-In are stored in Scenes. When a Scene is recalled, if the Plug-In’s Target is the same as when the Scene was stored, the parameters are set accordingly and the corresponding MIDI data is transmitted (so long as the REMOTE parameter is set to ENABLED). If the Target is not the same, the parameters are set accordingly but no MIDI data is transmitted.

## About the GEQs

The DM2000 features six 31-band graphic equalizers that can be inserted into the Bus Outs, Aux Sends, or the left or right channels of the Matrix Sends or Stereo Out. GEQs can be linked for simultaneous operation. GEQ settings can be stored in the GEQ library, which contains 1 preset memory and 128 user memories. See “GEQ Library” on page 168 for more information.

## Editing GEQs

GEQs can be edited as follows.

- 1 Press the **EFFECTS/PLUG INS [GRAPHIC EQUALIZERS]** button.
- 2 Use the **EFFECTS/PLUG INS [1–6]** buttons to select the GEQs.
- 3 Use the **EFFECTS/PLUG INS [DISPLAY]** button to locate the GEQ Edit page.

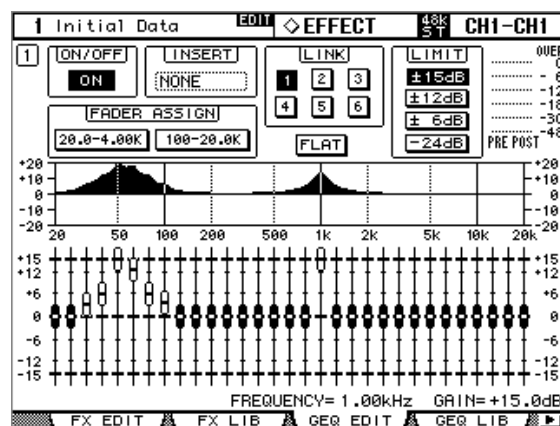

- 4 Use the cursor buttons to select the parameters, and use the Parameter wheel, INC/DEC buttons, and [ENTER] button to set them.

**ON/OFF:** This is used to turn on and off the currently selected GEQ.

**INSERT:** This selects the Output Channel (Bus Out, Aux Send, or left or right channel of a Matrix Send or the Stereo Out) into which the GEQ is inserted. This parameter can also be set on the Output Channel Insert page (see page 135) or the Graphic Equalizer Insert page (see page 82).

**LINK:** These buttons are used to link the currently selected GEQ with another GEQ for simultaneous operation. The buttons of GEQs that are already linked are unavailable. When you press a button to link to a GEQ, the settings of the currently selected GEQ are copied to that GEQ.

**FADER ASSIGN:** Use the channel faders to set the gain for each band, much like an analog graphic equalizer. Selecting the 20.0–4.0k button assigns a lower range to the channel faders; selecting the 100–20.0k button assigns a higher range.

**LIMIT:** This determines the maximum amount of boost and cut for the currently selected GEQ. It can be set to  $\pm 15$  dB,  $\pm 12$  dB,  $\pm 6$  dB, or  $-24$  dB.

**FLAT:** Pressing this resets all bands of the currently selected GEQ to 0 dB.

**Meters:** These meters display pre-GEQ and post-GEQ signal levels.

**CURVE:** This graphically displays the settings of the currently selected GEQ.

**Faders:** These are used to boost and cut the level of each band. The currently selected band can be reset to 0 dB by pressing [ENTER].

**FREQUENCY:** This indicates the frequency of the currently selected band.

**GAIN:** This indicates the gain setting of the currently selected band.

GEQ parameters can also be adjusted by using Parameter controls #1 and #4. Parameter control #1 selects the frequency bands. Parameter control #4 resets the gain of the selected band. Parameter controls #2 and #3 are inactive.

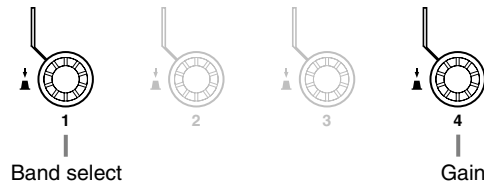

## Editing the Graphic EQ Using the Channel Faders

Use the channel faders to set the gain for each band, much like an analog graphic equalizer.

- 1 To assign a band to a channel fader, after editing GEQs as described in the previous paragraph, use the cursor buttons to select the 20.0–4.0k button or the 100–20.0k button in the FADER ASSIGN section, then press the [ENTER] button.

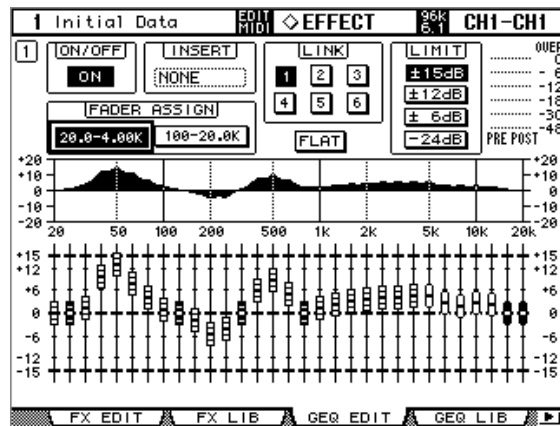

**20.0–4.0k:** This button selects 24 low range bands (20.0 Hz–4.0 kHz).

**100–20.0k:** This button selects 24 high range bands (100 Hz–20.0 kHz).

Each channel strip display indicates the frequency of the assigned band.

- 2 Move the channel faders to set the gain for each band.

When you move the faders, the corresponding channel strip displays indicate the gain value for one second. Pressing the channel [SEL] button moves the cursor to the corresponding band. Pressing the channel [SEL] button resets the gain for the corresponding band to 0.0 dB.

This function is available only when the Graphic Equalizer Edit page or Graphic Equalizer Library page is selected. If you access other pages, the fader assignment is cancelled.



# 16 Scene Memories

## About Scene Memories

Scene memories allow you to store a snapshot of virtually every DM2000 mix setting in a Scene. There are 99 Scene memories, and they can be titled for easy identification. A fade time of up to 30 seconds can be set individually for each Input and Output Channel fader. Recall Safe can be used to exclude individual Input and Output Channels and certain parameters from Scene recalls. Stored Scenes can be sorted as necessary.

Scenes can be stored and recalled by using the SCENE MEMORY [STORE] and [RECALL] buttons, or by using the Scene Memory page. Scenes can be assigned MIDI Program Change numbers and recalled remotely. See “Assigning Scenes to Program Changes” on page 218 for more information. When a Scene is recalled on the DM2000, the Program Change number assigned to that Scene is transmitted, which can be used to recall programs, effects, etc., on other MIDI equipment. In addition, manual Scene recalls can be recorded on-the-fly in an Automix. When that Automix is replayed, the Scenes are recalled automatically. See “Automix” on page 193 for more information.

Scene memories can be stored to external MIDI device, such as a MIDI data filer, by using MIDI Bulk Dump (see page 220). They can also be stored to SmartMedia (see page 271).

## What’s Stored in a Scene?

The following items are stored in Scenes: Input and Output Channel settings, Effects settings, GEQ settings, Group and Pair settings, Fade Time settings, and Scene title.

## Edit Buffer & Edit Indicator

The Edit Buffer is where the current mix settings (i.e., the current Scene) are stored. When a Scene is stored, the mix settings in the Edit Buffer are written to the selected Scene memory. When a Scene is recalled, the contents of the selected Scene memory are copied to the Edit Buffer, making them the current mix settings.

When a parameter is adjusted after a Scene has been recalled, the Edit indicators—the dot on the SCENE MEMORY display and “EDIT” on the display—appear, indicating that the current mix settings (i.e., those in the Edit Buffer) no longer match those of the Scene that was recalled last, as illustrated below.

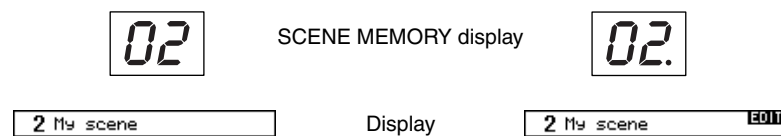

Scene #2 has just been recalled, so the contents of the Edit Buffer match those of Scene #2 and the Edit indicators are off.

A parameter has been adjusted since Scene #2 was recalled, so the Edit indicators appear, indicating that the contents of the Edit Buffer no longer match those of Scene #2.

The contents of the Edit Buffer are retained while the DM2000 is turned off.

## Scene Memories #0 & #U

Scene memory #0 is a special read-only memory that contains the initial settings of all mix parameters. It can be recalled, but not stored. When you want to reset all mix parameters to their initial, or default values, recall Scene memory #0. Input Channel faders are set to either  $-\infty$ dB or nominal, depending on the Initial Data Nominal preference (see page 275).

Scene memory #U is a special read-only memory that allows you to undo and redo Scene memory recall and store operations. After recalling a Scene memory, you can revert to the previously recalled Scene memory by recalling Scene memory #U. After storing a Scene memory, you can revert it to its previous contents by recalling Scene memory #U. You can redo either of these undo operations by recalling Scene memory #U again.

## Auto Scene Memory Update

Normally, when a Scene is recalled and then edited, that Scene must be stored again in order to save the edits. If the Scene MEM Auto Update preference on page 276 is on, however, those edits are stored automatically in a Shadow memory. There's one Shadow memory for each Original Scene memory. The contents of the Original and Shadow memories can be recalled alternately, which is useful for doing A/B comparisons.

When a Scene is recalled, the current mix settings are automatically stored in the Shadow memory of the Scene memory that was recalled last. When you return to that Scene, you can recall the Shadow or Original memory alternately.

While the Scene MEM Auto Update preference is on, Shadow memories, not Original memories are recalled initially. To recall an Original memory, recall its Shadow memory first, and while the Edit indicators are both off, recall again. This time the Original memory is recalled.

When recalling Original and Shadow memories, you can easily tell which is currently active by the Edit indicators, which are off when an Original memory is active, and on when a Shadow memory is active. Note that when a Scene is stored, the contents of the Original and Shadow memories will be the same and the Edit indicators will be off regardless of which memory is active.

When storing data to SmartMedia, Shadow memories are automatically stored along with their Original memories. When recalling Scenes in an Automix, only the Original memories can be recalled. Operation is the same as for recalling Scenes by using the DM2000's SCENE MEMORY buttons or the Scene Memory page.

## Storing & Recalling Scenes with the SCENE MEMORY Buttons

As each Scene memory is selected, its number flashes on the SCENE MEMORY display, and its number and title flash in the Scene memory section of the display. These stop flashing when the selected Scene memory is either stored or recalled. Empty Scene memories have the title “No Data!” and cannot be recalled. You cannot store to Scene memories that are write-protected.

*Warning: When storing Scenes, make sure that there are no settings in the Edit Buffer that you do not want to store. Perhaps some settings have been adjusted accidentally, or by someone else. If you are not sure of the Edit Buffer’s exact contents, recall the last Scene, make the adjustments that you really want, and then store the Scene. You may want to store the current Scene to an unused Scene memory just in case.*

### Storing Scenes

- 1 Use the SCENE MEMORY Up [▲] and Down [▼] buttons to select a Scene memory.**

- 2 Press the [STORE] button.**

The Title Edit window appears. This window can be disabled by the Store Confirmation preference on page 275.

- 3 Enter a title.**

See “Title Edit Window” on page 54 for more information.

- 4 Press OK on the Title Edit window.**

The current Scene is stored to the selected Scene memory.

You can undo Scene stores, reverting to the previous mix settings, by recalling Scene memory #U (“Ud” on the SCENE MEMORY display).

### Recalling Scenes

- 1 Use the SCENE MEMORY Up [▲] and Down [▼] buttons to select a Scene memory.**

- 2 Press the [RECALL] button.**

The contents of the selected Scene memory are recalled and all mix parameters are set accordingly. If the Recall Confirmation preference is on, a confirmation window appears before a Scene is recalled.

You can undo Scene recalls, reverting to the previous mix settings, by recalling Scene memory #U (“Ud” on the SCENE MEMORY display).

## Using the Scene Memory Page

On the Scene Memory page you can store, recall, write-protect, delete, and edit the titles of Scenes.

- 1 Use the **SCENE MEMORY [DISPLAY]** button to locate the Scene Memory page.

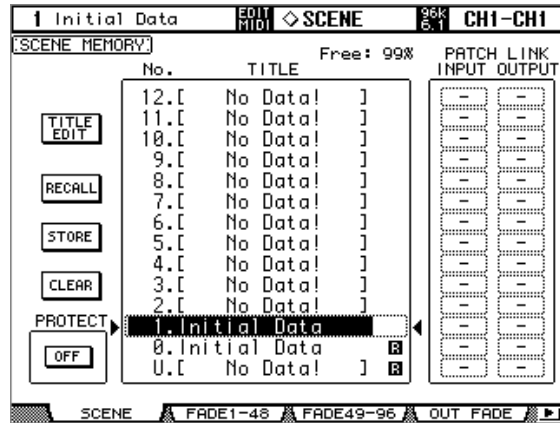

- 2 Use the **Parameter wheel or INC/DEC buttons** to select a Scene memory.

A Scene memory is selected when it appears inside the dotted box.

- 3 Use the **cursor buttons** to select the following buttons.

**TITLE EDIT:** To edit the title of the selected Scene memory, select this and press [ENTER]. When the Title Edit window appears, edit the title, and press OK when you've finished. See "Title Edit Window" on page 54 for more information.

**RECALL:** To recall the contents of the selected Scene memory, select this and press [ENTER]. The contents of the selected Scene memory are recalled, all parameters are set accordingly, the Scene memory's number and title stop flashing, and the Edit indicators go off. If the Recall Confirmation preference is on, a confirmation window appears before a Scene is recalled.

**STORE:** To store the current Scene to the selected Scene memory, select this and press [ENTER]. When the Title Edit window appears, enter a title, and press OK. See "Title Edit Window" on page 54 for more information. When a Scene is stored, the Scene memory's number and title stop flashing, and the Edit indicators go off. You can stop the Title Edit window from appearing by turning off the Store Confirmation preference on page 275.

**CLEAR:** To delete the contents and title of the selected Scene memory, select this, press [ENTER], and the press YES when the confirmation window appears.

**PROTECT:** To protect the contents of the selected Scene memory, select this and press [ENTER]. A padlock icon appears next to the titles of Scene memories that are write-protected. Scenes cannot be stored to write-protected Scene memories. While the PROTECT button is selected, the selected Scene memory can be protected and unprotected by using the INC/DEC buttons.

**PATCH LINK:** This indicates the Input/Output Patch library number that is linked to each scene. When you store a scene, the number of the input/output patch that was most recently recalled or stored will automatically be linked with that scene. When you recall that scene, this library number will also be automatically recalled. You can also move the cursor to the parameter boxes and change the library numbers.

## Fading Scenes

Fade times can be specified for individual Input Channels, Bus Outs, Aux Sends, Matrix Sends, Stereo Out, and the Group Master. The fade time determines the time it takes the Input and Output Channel faders to move to their new positions when a Scene is recalled. Fade time settings can be specified for each Scene individually.

### 1 Use the SCENE MEMORY [DISPLAY] button to locate a Fade Time page.

The Fade Time parameters for Input Channels 1–48 appear on the Input CH1–48 Fade Time page, for Input Channels 49–96 appear on the Input CH49–96 Fade Time page, and those for the Bus Outs, Aux Sends, Matrix Sends, Stereo Out, and the Group Master appear on the Output Fade Time page.

Initial Data		MIDI		SCENE		48k ST		CH1-CH1	
INPUT FADE TIME									
CH25									
<input type="checkbox"/> Global Fade Time									
ALL INPUT CLEAR									
INPUT CH (sec)	1	2	3	4	5	6	7	8	
	00.0	00.0	00.0	00.0	00.0	00.0	00.0	00.0	
	9	10	11	12	13	14	15	16	
	00.0	00.0	00.0	00.0	00.0	00.0	00.0	00.0	
	17	18	19	20	21	22	23	24	
	00.0	00.0	00.0	00.0	00.0	00.0	00.0	00.0	
25	26	27	28	29	30	31	32		
00.0	00.0	00.0	00.0	00.0	00.0	00.0	00.0		
33	34	35	36	37	38	39	40		
00.0	00.0	00.0	00.0	00.0	00.0	00.0	00.0		
41	42	43	44	45	46	47	48		
00.0	00.0	00.0	00.0	00.0	00.0	00.0	00.0		

Initial Data		EDIT		SCENE		48k ST		CH50-CH50	
INPUT FADE TIME									
CH73									
<input type="checkbox"/> Global Fade Time									
ALL INPUT CLEAR									
INPUT CH (sec)	49	50	51	52	53	54	55	56	
	00.0	00.0	00.0	00.0	00.0	00.0	00.0	00.0	
	57	58	59	60	61	62	63	64	
	00.0	00.0	00.0	00.0	00.0	00.0	00.0	00.0	
	65	66	67	68	69	70	71	72	
	00.0	00.0	00.0	00.0	00.0	00.0	00.0	00.0	
73	74	75	76	77	78	79	80		
00.0	00.0	00.0	00.0	00.0	00.0	00.0	00.0		
81	82	83	84	85	86	87	88		
00.0	00.0	00.0	00.0	00.0	00.0	00.0	00.0		
89	90	91	92	93	94	95	96		
00.0	00.0	00.0	00.0	00.0	00.0	00.0	00.0		

Initial Data		EDIT		SCENE		48k ST		CH50-CH50	
OUTPUT/GROUP MASTER FADE TIME									
BUS1									
<input type="checkbox"/> Global Fade Time									
ALL CLEAR									
BUS (sec)	1	2	3	4	5	6	7	8	
	00.0	00.0	00.0	00.0	00.0	00.0	00.0	00.0	
AUX (sec)	1	2	3	4	5	6	7	8	
	00.0	00.0	00.0	00.0	00.0	00.0	00.0	00.0	
MATRIX (sec)	1	2	3	4	STEREO	ST			
	00.0	00.0	00.0	00.0	(sec)	(sec)			
INPUT MASTER (sec)	A	B	C	D	E	F	G	H	
	00.0	00.0	00.0	00.0	00.0	00.0	00.0	00.0	
OUTPUT MASTER (sec)	Q	R	S	T					
	00.0	00.0	00.0	00.0					

### 2 Use the cursor buttons or [SEL] buttons to select the individual Fade Time parameters, and use the Parameter wheel or INC/DEC buttons to set them.

You can copy the currently selected Input or Output Channel Fade Time setting to all Input or Output Channels respectively by double-clicking the [ENTER] button. If the Input or Output Group Master is selected, you can copy the setting to all Input or Output Channel Group Master channels.

The Long name of the channel whose Fade Time parameter is currently selected appears in the upper-right corner of the page. When a channel is selected by using the [SEL] buttons, its Long name also appears in the upper-right corner of the display.

The Fade Time can be set from 0 to 30 seconds in 0.1 second steps.

You can reset all Input Channel Fade Time parameters to zero by selecting the ALL INPUT CLEAR buttons, then pressing the [ENTER] button. You can reset all Output Channel Fade Time parameters to zero by selecting the [ALL CLEAR] buttons, then pressing the [ENTER] button.

**Global Fade Time:** When this check box is checked, a Scene is recalled using the Fade Time that is applied globally to all Scenes. (The Fade Time setting stored in the recalled Scene is temporarily ignored.)

## Recalling Scenes Safely

When a Scene is recalled, all mix parameters are set accordingly. In some situations, you may want to retain the settings of certain parameters on certain channels, and this can be achieved by using the Recall Safe function. Recall Safe can be set individually for Input/Output Channels, Group Master, Internal Effect Processor, and the Remote Layer, etc.

- 1 Use the **SCENE MEMORY [DISPLAY]** button to locate the Recall Safe page.

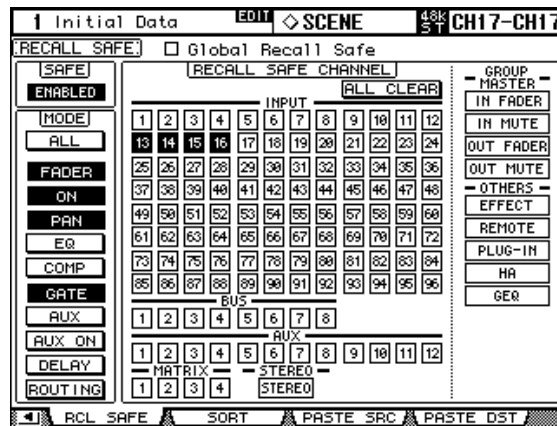

- 2 Select the **SAFE ENABLED/DISABLED** button, and use the **[ENTER]** button or the **INC/DEC** buttons to enable or disable the Recall Safe function.
- 3 Use the cursor buttons, **[SEL]** buttons, or Parameter wheel to select channels, and use the **[ENTER]** button or the **INC/DEC** buttons to set them as Safe channels.

When a channel is Safe, its number appears highlighted.

**GROUP MASTER/OTHERS:** Recall Safe can be set individually not only for Input/Output Channels, but also Group Master, Internal Effect Processors, User Defined Remote Layer, Plug-ins, HA (AD8HR/AD824), and GEQ.

- 4 Use the cursor buttons or Parameter wheel to select the **MODE** parameters, and the **[ENTER]** button to set them.

The **MODE** buttons determine which Safe channel parameters are unaffected by Scene recalls. **ALL** (all parameters. This option is mutually exclusive with the following options), **FADER** (faders), **ON** (On/Off parameters), **PAN** (Pan parameters), **EQ** (EQ parameters), **COMP** (Comp parameters), **GATE** (Gate parameters), **AUX** (Aux/Matrix Send levels), **AUX ON** (Aux/Matrix Send On/Off parameters), **DELAY** (Delay parameters), **ROUTING** (Routing parameters).

**GLOBAL RECALL SAFE:** When this check box is checked, a Scene is recalled using the settings that are applied globally to all Scenes. The settings stored in the recalled Scene are temporarily ignored.

Recall Safe settings are stored in Scene memories.

## Sorting Scenes

Scene can be sorted by using the Scene Memory Sort function.

- 1 Use the SCENE MEMORY [DISPLAY] button to locate the Scene Memory Sort page.

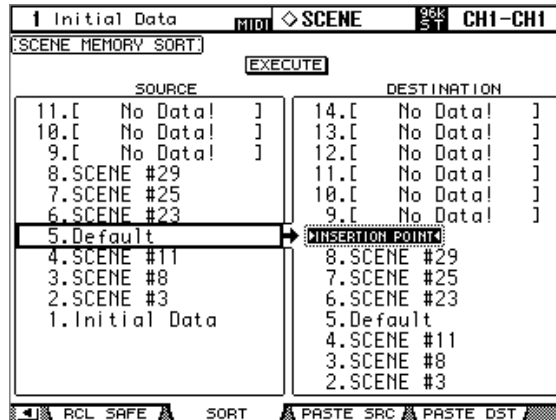

- 2 Use the cursor button to select the SOURCE list, and use the Parameter wheel or the INC/DEC buttons to select the Scene memory you want to move.
- 3 Use the cursor button to select the DESTINATION list, and use the Parameter wheel or the INC/DEC buttons to select the position to which you want to move the source Scene memory.
- 4 Press [ENTER] to move the source Scene memory to the specified destination.

The [ENTER] button executes the Sort function regardless of its position.

## Copying and Pasting a Scene (Global Paste)

Any channel or parameter settings for the current scene can be copied and pasted into other scenes. This function is useful when you want to apply edited parameter settings in the current scene to other scenes.

- 1 Use the SCENE MEMORY [DISPLAY] button to locate the Global Paste Source CH Select page.

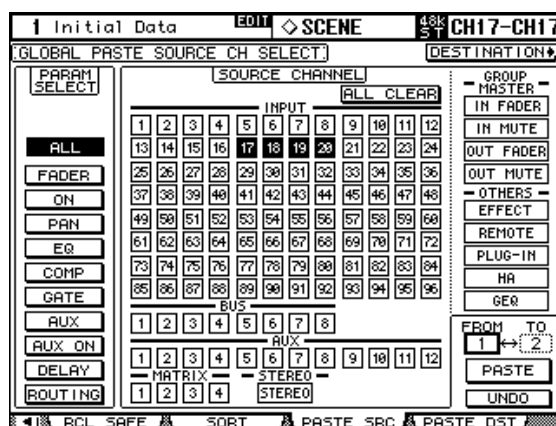

- 2 Use the cursor buttons, [SEL] buttons, or Parameter wheel to select the channel category, then use the [ENTER] button or the INC/DEC buttons to select the copy source channel.

The number of the source channel is highlighted.

**GROUP MASTER/OTHERS:** You can also select Group Masters, internal Effects processors, a User Defined Remote layer, User Defined Plug-in, HA (AD8HR/AD824), or GEQ as copy sources.

- 3 Use the cursor buttons or Parameter wheel to select the copy source parameter, then press the [ENTER] button.
- 4 Use the cursor buttons or Parameter wheel to select the destination channels, then press the [ENTER] button.
- 5 Use the SCENE MEMORY [DISPLAY] button to locate the Global Paste Destination Scene page.

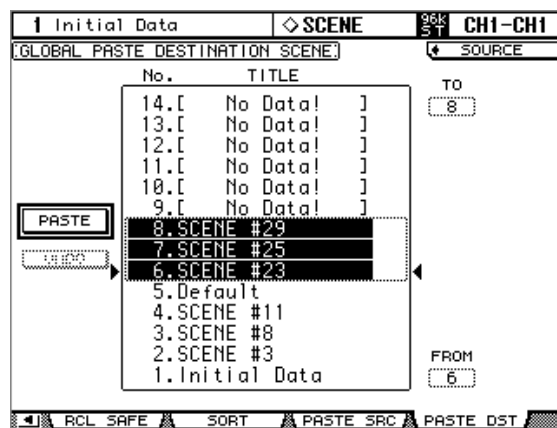

- 6 Use the Parameter wheel or INC/DEC buttons to select the destination scene(s).  
Scenes specified between FROM and TO (inclusive) become the paste destination. You can paste up to 10 scenes at a time.
- 7 Use the cursor buttons to select the PASTE button, then use the [ENTER] button to paste the settings.

You cannot paste the settings to write-protected scenes.

**UNDO:** This button restores the settings used prior to the paste operation. However, if the settings in the scene are changed after the paste operation (such as by saving, clearing, or sorting the scene, loading scene data from SmartMedia, or receiving scene data via MIDI Bulk Dump), the UNDO function is disabled.



# 17 Automix

## About Automix

The DM2000's Automix function allows dynamic automation of virtually all mix parameters, including Levels, Mutes, Pan, Surround Pan, Aux/Matrix Sends, Aux/Matrix Send Mutes, EQ, effects, and Plug-Ins. You can specify which of these parameters will be recorded, and punch channels in and out of recording on-the-fly. User Defined Remote Layer operations, and scene and library recall operations can also be automated, combining snap shot and dynamic mix automation. Events are recorded in real time and can be edited either offline, with 1/4 frame accuracy, or by rerecording with punch in/out. Automix can be synchronized to an external timecode source or to the internal timecode generator.

Up to 16 Automixes can be stored in the Automix library. See "Automix Library" on page 173 for more information. They can also be stored to an external MIDI device, such as a MIDI data filer, by using MIDI Bulk Dump (see page 220), or stored to SmartMedia (see page 271).

## What's Recorded in an Automix?

The following parameters can be recorded in an Automix.

Parameter	Input Channels	Bus Out Masters	Aux Send Masters	Matrix Send Masters	Stereo Out
Channel Levels (faders)	O	O	O	O	O
Channel Mutes (ON/OFF)	O	O	O	O	O
Pan	O	—	—	—	—
Surround Pan	O	—	—	—	—
EQ (F, Q, G, On/Off)	O	O	O	O	O
Aux Send 1–12 levels	O	—	—	—	—
Aux Send 1–12 mutes	O	—	—	—	—
Matrix Send 1–4 levels	—	O	O	—	O
Matrix Send 1–4 mutes	—	O	O	—	O
Feder Group Master (Level, On/Off)			—		
Scene recalls			—		
EQ, Gate, Comp, Effects, Channel library recalls			—		
Effect parameters (certain parameters)			—		
User Defined Plug-Ins (parameters 1–4)			—		
User Defined Remote Layers (faders, [ON], Encoders)			—		

## Automix Main Page

This section explains the Automix Main page.

- 1 Use the **AUTOMIX [DISPLAY]** button to locate the Automix Main page.

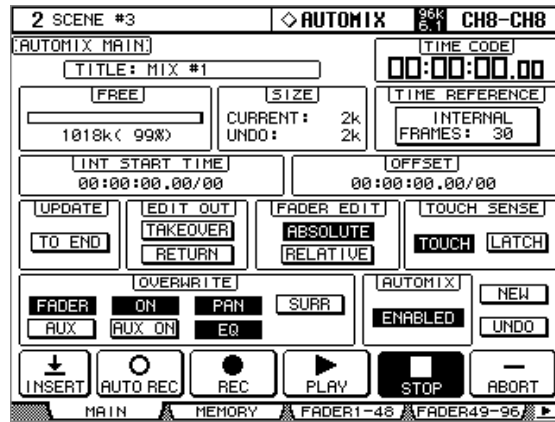

- 2 Use the cursor buttons to select the parameters, and use the Parameter wheel, INC/DEC buttons, and [ENTER] button to set them.

**TITLE:** This is the title of the current Automix.

**TIME CODE:** This counter displays the current timecode position. If the optional MB2000 Peak Meter Bridge is installed, the current timecode position is also displayed on its TIME CODE counter.

**FREE:** The amount of free Automix memory remaining is displayed here in kilobytes, percent, and graphically by a bargraph.

**SIZE:** The size of the current Automix and the size of any Automix data in the undo buffer are displayed here in kilobytes.

**TIME REFERENCE:** This section displays the current timecode source and frame rate. If you select this item and then press the [ENTER] button, you can jump directly to the Time Reference page (see page 201).

**INT START TIME:** This parameter is used to set the start time of the internal timecode generator in hours, minutes, seconds, frames, and subframes. Press the [ENTER] button to reset the currently selected digits to “00.” The internal timecode generator is selected on the Time Reference page (see page 201).

**OFFSET:** This parameter can be used to specify an offset relative to the external timecode source in hours, minutes, seconds, frames, and subframes. Specify a “+” value to move events forward relative to the incoming timecode. Specify a “-” value to move events backward relative to the incoming timecode. Press the [ENTER] button to reset the currently selected digits to “00.” If the Timecode Display Relative preference is turned on (see page 277), the indicated timecode is offset.

**UPDATE:** This button determines the fate of events that exist beyond the point at which rerecording is stopped. When TO END is on, all events that exist beyond the point at which rerecording is stopped for parameters that have been edited during the current pass are erased. This function is useful when you want parameters to remain the same right through to the end of the Automix. Events are erased only when the current pass is actually stopped, not when a punch out occurs. When TO END is off, existing events are left as they are.

When TO END is on, the way in which Fader events are processed depends on the currently selected Fader Edit mode and Edit Out mode. In the following table, the Fader Edit mode is set to Absolute. If the Fader Edit mode is set to Relative, and the Edit Out mode is set to either Takeover or Off, the fader will remain at a position relative to the position at which recording is stopped.

	Return	Takeover or Off
TO END is OFF	<p>At the point at which recording is stopped, the fader returns to the position specified by the existing fader data, at the speed specified by the Time parameter on the Fader Edit pages.</p>	<p>At the point at which recording is stopped, the fader remains at the same position until the next Fader event in the existing data occurs.</p>
TO END is ON	<p>At the point at which recording is stopped, the fader returns to the position specified by the existing fader data, at the speed specified by the Time parameter, and all subsequent events are erased so that the fader remains at that position right through to the end of the Automix.</p>	<p>At the point at which recording is stopped, all subsequent events are erased so that the fader remains at that position right through to the end of the Automix.</p>

**EDIT OUT:** These buttons are used to set the Edit Out mode: Off, Takeover, or Return. The Edit Out mode determines how rerecorded fader moves align with existing fader data at the punch out point. Fader data includes Input Channel levels, Bus Out master levels, Aux Send master levels, Matrix Send master levels, the Stereo Out level, User Defined Remote Layer faders, and Group master levels. The Edit Out modes are explained in the following table. The Edit Out mode can also be set by using the AUTOMIX [RETURN] button. The Return Time is specified on the Fader Edit page (see page 200).

Off	Return	Takeover
<p>At the punch out point, the fader remains at the same position until the next Fader event in the existing data occurs.</p>	<p>At the punch out point, the fader returns to the position specified by the existing fader data, at the speed specified by the Time parameter on the Fader Edit pages.</p>	<p>At the punch out point, recording continues until the fader position intersects the existing fader data. If you are still touching the fader knob at the actual punch out point, the fader is disabled until you release it.</p> <p>In this example, punch out was performed by pressing the [AUTO] button, and the fader was moved manually between the punch out and actual punch out points.</p>

**FADER EDIT:** These buttons are used to set the Fader Edit mode: Absolute or Relative. The Fader Edit mode determines how fader moves are rerecorded. It has no effect during the first recording pass. In Absolute mode, fader moves are rerecorded as absolute values and existing fader data is erased. In Relative mode, fader moves are rerecorded relative to the existing fader data.

Fader data includes Input Channel levels, Bus Out master levels, Aux Send master levels, Matrix Send master levels, Stereo Out level, User Defined Remote Layer faders, and Group master levels. The Fader Edit mode can also be set by using the AUTOMIX [RELATIVE] button.

The following table explains Fader Edit mode operation (TO END: off. Edit Out: off)

Absolute	Relative
Fader edits are recorded as absolute values and existing fader data between the punch in and out points is erased.	Fader edits are rerecorded relative to the existing fader data.

**TOUCH SENSE:** When the TOUCH button is selected, the Touch Sense function enables you to touch the faders to punch parameter values in and out. The corresponding parameters' OVERWRITE button must be set to on. When the LATCH button is selected, only punch in operations are available (the punch out function is disabled).

You can also turn on or off the Touch Sense function by pressing the AUTOMIX [TOUCH SENSE] button. This button memorizes the TOUCH and LATCH button selections on this page. For example, if the TOUCH button is selected on this page, pressing the AUTOMIX [TOUCH SENSE] button turns the TOUCH button on this page on or off. When the LATCH button is selected in this page, pressing the AUTOMIX [TOUCH SENSE] button turns the LATCH button on this page on or off.

**OVERWRITE:** These buttons determine which parameters can be recorded on the first pass, and rerecorded (i.e., overwritten) on subsequent passes. They can be set while recording is in progress. Parameters for which the corresponding OVERWRITE button is not set, cannot be edited while recording is in progress. They work in unison with the AUTOMIX [FADER], [ON], [PAN], [SURROUND], [AUX], [AUX ON] & [EQ] buttons.

Parameter button	Description
FADER	Channel faders (Inputs Channels, Bus Out masters, Aux Send masters, Matrix Send masters, the Stereo Out, Group master levels, and User Defined Layer faders)
ON	Channel Mutes (ON/OFF), User Defined Layer [ON] buttons, and Group master ON
PAN	Input Channel Pan, User Defined Layer Encoders
SURR	Input Channel Surround pan, LFE level, DIV parameter, and RDIV parameter
AUX	Aux/Matrix Send 1–12 levels
AUX ON	Aux/Matrix Send 1–12 mutes
EQ	EQ (F, Q, G, On/Off)

Scene and library recalls, and internal effects processors and Plug-Ins parameters can be recorded regardless of the OVERWRITE settings.

**AUTOMIX:** This button is used to enable and disable the Automix function. It works in unison with the AUTOMIX [ENABLE] button.

**NEW:** This button is used to create a new Automix. When a new Automix is created, a Scene recall event to recall the current Scene (i.e., the last Scene recalled) is automatically inserted at the start of the Automix. You can edit this event so that another Scene is recalled. This initial Scene is important because it sets all the mix parameters how you'd like them at the beginning of the Automix. Without it, mix parameters would remain the same as when Automix playback was stopped.

**UNDO:** This button is used to undo various Automix operations. During each recording pass, when a new Automix is created, when an Automix is recalled, when an offline edit is performed, or when the Undo function is used, the current Automix data is copied to the Undo buffer, from which it can be retrieved by pressing UNDO while Automix is stopped. This button works in unison with the AUTOMIX [ABORT/UNDO] button.

**INSERT:** The INSERT button inserts the current Scene into the current Automix data. This is useful when you want to quickly swap out a specified range of the Automix data, such as a line of dialog. See "Inserting Mix Parameters into Automix" on page 203 for more information.

**AUTO REC:** This button works the same as the REC button except that it remains on when Automix recording is stopped. It appears highlighted while Auto Record mode is on. It works in unison with the AUTOMIX [AUTO-REC] button.

**REC:** This button is used to engage Record-Ready mode, in which Automix recording starts automatically as soon as the specified timecode source starts. Unlike the AUTO REC button, however, it's turned off when recording is stopped. It flashes in Record-Ready mode, and is highlighted during recording. This button can also be used to engage Automix recording during playback. To do this, while the PLAY button is highlighted (i.e., during playback), press the REC button (it flashes in Record-Ready mode). Then press the PLAY button to start recording. This button works in unison with the AUTOMIX [REC] button.

**PLAY:** This button is used to start Automix recording and playback when the timecode source is set to internal. When an external timecode source is selected, while the external timecode is being received, recording and playback are started, and this button is turned on automatically. If Automix is stopped by pressing the STOP or ABORT button, recording or playback can be restarted by pressing this button so long as timecode is still being received. This button can also be used in conjunction with the REC button to punch in recording during Automix playback.

**STOP:** This button is used to stop Automix playback and recording. It appears highlighted while Automix is stopped.

**ABORT:** This button is used to abort the current recording without updating the existing Automix data. Automix recording can also be aborted by pressing the AUTOMIX [ABORT/UNDO] button.

## AUTOMIX Section

Certain Automix functions and parameters can be controlled by using the buttons in the AUTOMIX section.

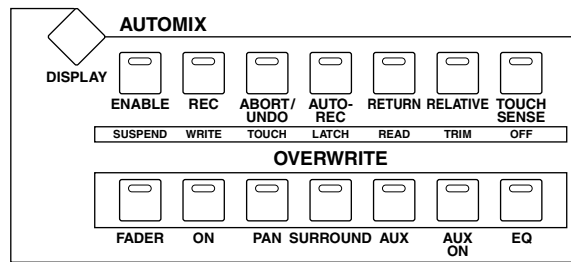

**[DISPLAY] button:** This button is used to select the following Automix pages: Main, Memory, Fader Edit, Event Copy, and Event Edit.

**[ENABLE] button:** This button is used to enable and disable the Automix function. It works in unison with the ENABLED/DISABLED button on the Automix Main page.

**[REC] button:** This button can be used to engage Record-Ready mode from stop, engage recording during playback, and to stop recording. Its indicator flashes in Record-Ready mode, and lights continuously during recording. Pressing this button along with the [AUTO REC] button places the DM2000 in Insert mode (see page 203).

**[ABORT/UNDO] button:** This button is used to abort Automix recording or playback. While Automix is stopped, it performs the undo function, reverting to the Automix in the Undo buffer. It works in unison with the ABORT and UNDO buttons on the Automix Main and Memory pages.

**[AUTO-REC] button:** This button is used to turn Auto Recording on and off. Its indicator lights up while Auto Record is on. It works in unison with the AUTO REC button on the Automix Main and Memory pages.

**[RETURN] button:** This button is used to set the Edit Out mode. It works in unison with the EDIT OUT RETURN buttons on the Automix Main and Memory pages. When its indicator is on, Return mode is set. When its indicator is flashing, Takeover mode is set. And when its indicator is off, neither mode is set.

**[RELATIVE] button:** This button is used to set the Fader Edit mode. It works in unison with the FADER EDIT buttons on the Automix Main and Memory pages. When its indicator is off, Absolute mode is set. When its indicator is on, Relative mode is set.

**[TOUCH SENSE] button:** This button is used to turn Automix recording on and off via Fader Touch Sense. It works in unison with the TOUCH buttons on the Automix Main pages and the Fader Edit pages (see page 194 and 199).

**[FADER], [ON], [PAN], [SURROUND], [AUX], [AUX ON] & [EQ] buttons:** These buttons determine which parameters can be recorded on the first pass, and rerecorded (i.e., overwritten) on subsequent passes. They work in unison with their counterparts on the Automix Main and Memory pages.

## Channel Strip [AUTO] Buttons

The channel strip [AUTO] buttons are used to arm channels in Record-Ready mode, and to punch channels in and out during recording.



The [AUTO] button indicators operate as follows:

- Off: Automix playback disabled
- Green: Automix stopped or playing
- Orange: Record-Ready mode
- Red: Recording (even for individual parameters, see page 207)
- Flashing red: Takeover in progress
- Flashing green: indicates that a fader is inactive, for example, when you continue touching a fader after actual punch out has occurred when using the Takeover Edit Out mode.

## Automix Memory Page

Automixes can be stored and recalled on the Automix Memory page. The lower half of this page is identical to the Automix Main page.

- 1 Use the **AUTOMIX [DISPLAY]** button to locate the Automix Memory page.

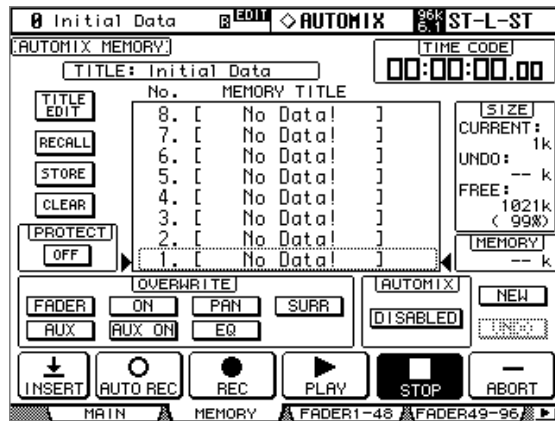

- 2 Use the cursor buttons to select the parameters, and use the Parameter wheel, INC/DEC buttons, and [ENTER] button to set them.

The Automix library functions are explained in “Automix Library” on page 173. The remaining items are the same as on the Main page and are explained on page 194.

## Fader Edit Pages

During playback, fader positions are displayed graphically as black bars on the Fader Edit page, of which there are three. The CH1–48 Fader Edit page displays Faders positions for Input Channel 1 through 48, the Bus Outs, Aux Sends, and Stereo Out. The CH49–96 Fader Edit page displays faders positions for Input Channel 49 through 96, the Bus Outs, Aux Sends, and Matrix Sends. The Group Fader Edit page displays the fader position for the Input Group Master Levels and Output Group Master Levels. When the Fader mode is set to Fader, Input and Output Channel levels are displayed. When it’s set to Aux/Mtrx mode, Aux/Matrix Send levels are displayed.

During rerecording, arrows are displayed next to each fader bar. A downward arrow indicates that the current fader position is higher than that specified by the existing fader data. An upward arrow indicates that the current fader position is lower than that specified by the existing fader data.



## 1 Use the AUTOMIX [DISPLAY] button to locate the Fader Edit pages.

The CH1–48 Fader Edit page is shown here.

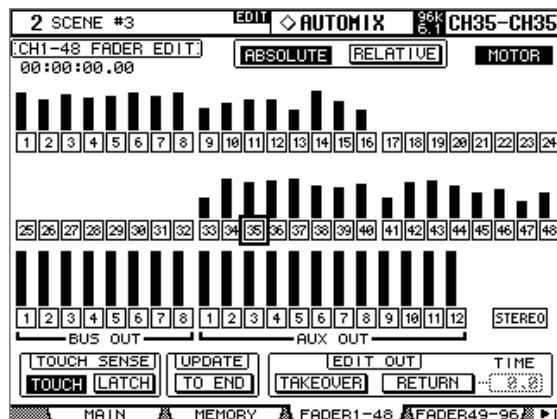

## 2 Use the cursor buttons to select the parameters, and use the Parameter wheel, INC/DEC buttons, and [ENTER] button to set them.

The counter in the upper-left corner displays the current timecode position.

**Edit Safe buttons:** The numbered buttons below each fader bar are Channel Safe buttons, which can be used to prohibit automix recording on certain channels. A channel is set to safe when its button appears highlighted.

You can make all channels safe by selecting one “non-safe” button and double-clicking the [ENTER] button. A confirmation message appears.

You can cancel all safe channels by selecting one “safe” button and double-clicking the [ENTER] button. A confirmation message appears.

During recording, events cannot be recorded, or rerecorded on safe channels, although existing events are played back and faders, Encoders, [ON] buttons, and so on can still be used, which is useful for rehearsing mix moves. Channel safe settings cannot be changed during recording.

**ABSOLUTE & RELATIVE:** These buttons are the same as those on the Main and Memory pages. See “Automix Main Page” on page 194 for more information.

**MOTOR:** This button is used to turn the fader motors on and off for Automix playback. The button appears highlighted when the motors are on. The motors cannot be turned off during recording, and are automatically turned on when recording starts.

**TOUCH SENSE:** This button is the same as the TOUCH SENSE button on the Automix Main page (see page 196).

**UPDATE:** This button is the same as that on the Main and Memory pages. See “Automix Main Page” on page 194 for more information.

**EDIT OUT:** The TAKEOVER and RETURN buttons are the same as those on the Main and Memory pages. See “Automix Main Page” on page 194 for more information. The TIME parameter determines the time it takes faders to return to levels specified by the existing Automix data when the Edit Out mode is set to Return. It can be set from 0.0 to 30.0 seconds in 0.1 second steps.



## Selecting the Timecode Source & Frame Rate

The timecode source and frame rate for Automix can be set as follows.

- 1 Use the **DISPLAY ACCESS [SETUP]** button to select the **Time Reference** page.

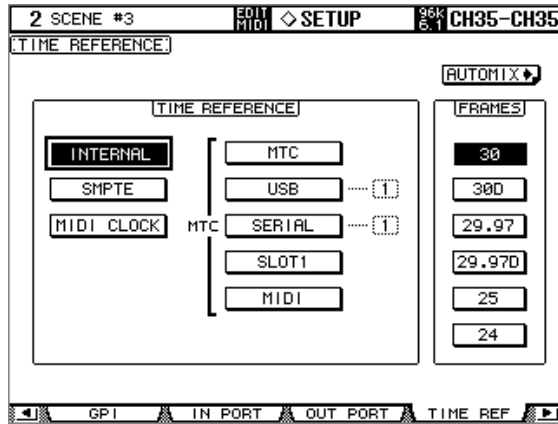

- 2 Use the cursor buttons to select the parameters, and use the Parameter wheel, INC/DEC buttons, and [ENTER] button to set them.

**TIME REFERENCE:** The following timecode sources can be selected.

Source	Description
<b>INTERNAL</b>	Internally generated timecode
<b>SMPTE</b>	SMPTE timecode received via the SMPTE TIME CODE INPUT
<b>MIDI CLOCK</b>	MIDI Clock received via the MIDI IN port
<b>MTC</b>	MTC received via the MTC TIME CODE INPUT
<b>USB</b>	MTC received via the USB TO HOST port
<b>SERIAL</b>	MTC received via the SERIAL TO HOST port
<b>SLOT1</b>	MTC received via Slot #1 (for use with an optional mLAN I/O Card installed in Slot #1)
<b>MIDI</b>	MTC received via the MIDI IN port

For the USB and SERIAL sources, you must specify a port from 1–8.

**FRAMES:** The frame rate can be set to: 30, 30D, 29.97, 29.97D, 25, or 24. An Automix will playback correctly even if the frame rate is different to that which was used when the Automix was originally recorded.

The MIDI CLOCK source supports Song position Pointers, F8 TIMING CLOCK (timing info), FA START (starts Automix from beginning), FB CONTINUE (starts Automix from current position), and FC STOP (stops Automix).

## Creating a Time Signature Map

When using the MIDI CLOCK timecode source, you'll also need to specify the initial time signature and any time signature changes that follow.

- 1 Use the **DISPLAY ACCESS [SETUP]** button to select the Time Signature page.

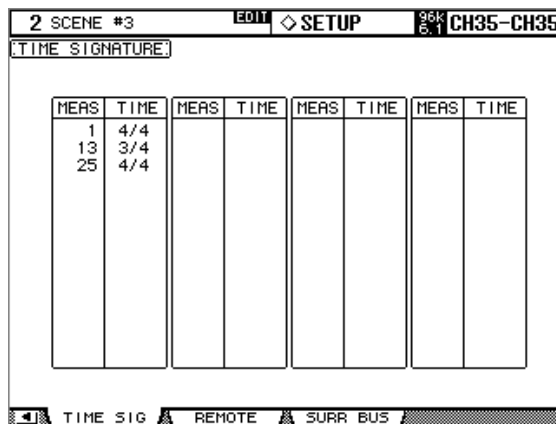

- 2 Use the cursor buttons to select the parameters, and use the Parameter wheel or INC/DEC buttons to specify the measure and time signature.

To insert a time signature change, use the cursor buttons to select the next available entry, and press [ENTER], or turn the Parameter wheel.

To delete a time signature change, select it, and then press [ENTER]. The initial time signature entry at measure #1 cannot be deleted.

## Recording an Automix

This section provides a general procedure for Automix recording.

- 1 **Select the timecode source and frame rate.**  
See “Selecting the Timecode Source & Frame Rate” on page 201 for more information.
- 2 **Use the AUTOMIX [DISPLAY] button to locate the Automix Main page.**
- 3 **Press the AUTOMIX [ENABLE] button to enable the Automix function.**  
The AUTOMIX [ENABLE] button indicator lights up, and the ENABLED/DISABLED button on the Automix main page appears highlighted.
- 4 **Use the AUTOMIX OVERWRITE buttons to select which parameters you want to record.**  
The corresponding AUTOMIX OVERWRITE button indicators light up, and the corresponding OVERWRITE buttons on the Automix Main and Memory pages appear highlighted.
- 5 **Press the AUTOMIX [REC] button.**  
The AUTOMIX [REC] button indicator flashes, and the REC button on the Automix Main and Memory pages flashes.  
Alternatively, you could press the AUTOMIX [AUTO-REC] button so that Automix recording starts automatically when timecode is received. The main difference between REC and AUTO REC is that the AUTO REC functions remains on when recording is stopped. Whereas REC must be pressed each and every time you want to start recording. Initially however, REC may be the safer option.
- 6 **Use the [AUTO] buttons to arm channels for Automix recording.**  
The [AUTO] button indicators of armed channels light up orange.

**7 Start the timecode source.**

The AUTOMIX [REC] button indicator lights up continuously, and on the Automix Main and Memory pages, the REC and PLAY buttons appear highlighted.

**8 Adjust the faders and other controls as necessary.**

Use the SELECTED CHANNEL section to edit the currently selected channel. Channels are selected automatically when the [AUTO] buttons are pressed. You can punch channels out of recording by using the [AUTO] buttons.

**9 To stop Automix recording, stop the timecode source or press the STOP button on the Automix Main or Memory page.**

When the Mix Update Confirmation preference is on (see page 277), a confirmation message appears asking if you want to update the existing Automix data (i.e., keep the edits just recorded).

### Inserting Mix Parameters into Automix

You can insert the static mix parameter settings into the range specified by the IN and OUT parameters in the current Automix data. This is useful when you want to quickly insert static EQ settings into a specified range of the Automix data.

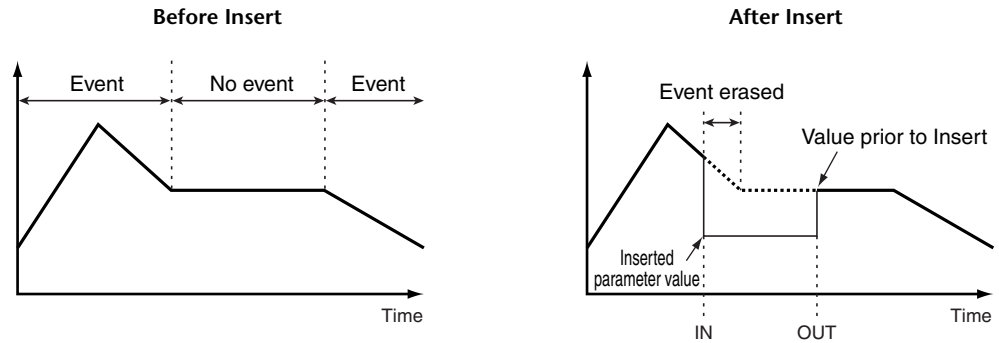

**1 Follow Steps 1–4 as described in the “Recording an Automix” section on the previous page, then press the AUTOMIX [DISPLAY] button to display the Automix Main page.**

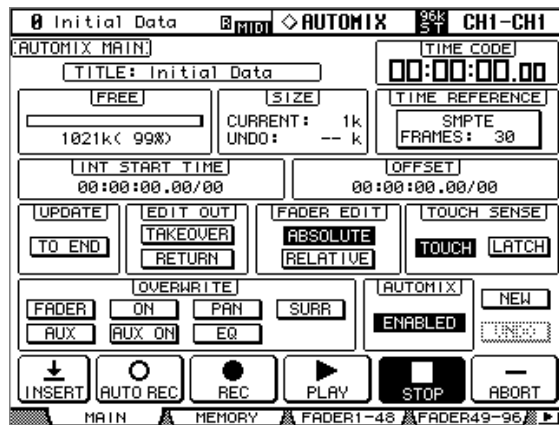

- 2 Use the cursor buttons to select the INSERT button, then press [ENTER]. Alternatively, press the AUTOMIX [REC] and [AUTO REC] buttons simultaneously.

A confirmation message appears.

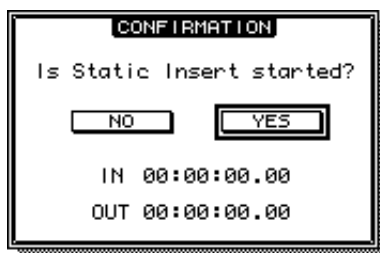

- 3 Use the IN and OUT parameters to specify the region to be inserted.

The default IN and OUT parameter values use the Locate memories specified by the Insert Time Link preference (see page 278). If you change the Locate points for the corresponding Locate memories while the confirmation message is displayed, the IN and OUT parameter values will be updated accordingly.

If MIDI clock is selected as a timecode source, these parameters indicate the position in bar:beats:clocks and use the IN and OUT parameter values in the TIME SETTING section on the Event Job page. In this case, the Insert Time Link preference is disabled.

- 4 Use the cursor buttons to select YES, then press [ENTER].

The DM2000 enters Insert mode, and the INSERT button is highlighted. The AUTOMIX [REC] and [AUTO REC] button indicators flash.

The fader positions, mute function and other parameters are updated to the settings specified for the time value of the IN parameter.

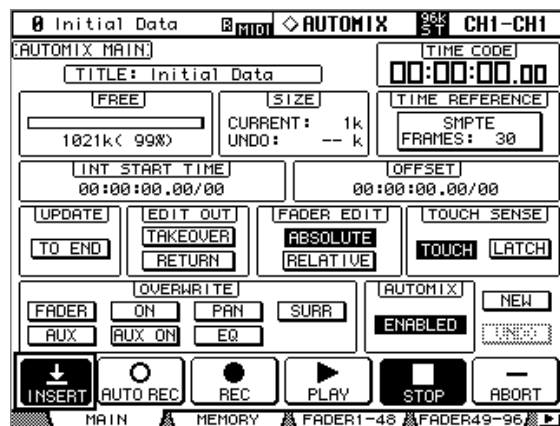

- 5 Select the parameter you wish to insert using the AUTOMIX OVERWRITE buttons.

To select effect or plug-in parameters, locate the Effect Edit or Plug-in Edit page, then move the cursor to the desired parameter and press [ENTER].

- 6 Select the insert destination channel by pressing the corresponding [AUTO] button.

The selected [AUTO] button indicator lights up red.

- 7 Edit a parameter you wish to insert.

It might be helpful to use loop playback (page 259) while editing the parameter if you wish to insert EQ parameters.

- 8 Use the cursor buttons to select the **INSERT** button, then press **[ENTER]**. Alternatively, press the **AUTOMIX [REC]** and **[AUTO REC]** buttons simultaneously.

A confirmation message appears.

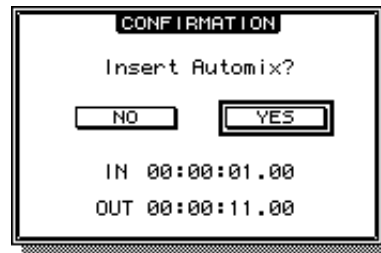

- 9 Use the cursor buttons to select **YES**, then press **[ENTER]** to insert the data. Once the data is inserted, Insert mode is cancelled and the **INSERT** button is unhighlighted.

## Rerecording Events

Events can be rerecorded as many times as you like. Remember, however, that unlike the first pass, on subsequent passes, existing events for the currently punched in parameter are overwritten, so use the **OVERWRITE** buttons and **[AUTO]** buttons with care. Instead of using the **[AUTO]** buttons to punch in an entire channel, you can reduce the risk of overwriting important data by punching in and out individual parameters (see page 207). Use the **Update To End** option to determine how existing events are handled when rerecording is stopped (see page 194). Use the **Edit Out** (see page 195) and **Fader Edit** (see page 196) options to determine how Fader events are rerecorded.

## Parameter Recording

The following table summarizes parameter recording operation for each parameter. Parameter adjustments made on the respective display pages are also recorded.

Parameter	Channel	OVERWRITE	Operation	Pair/Group
Channel Levels (faders)	Input	FADER	Set Layer to input, Fader mode to Fader, use faders	Faders of paired channels and grouped faders are recorded together
	Bus Out, Aux Send, Matrix Send		Set Layer to Master, Fader mode to Fader, use faders	
	Stereo Out		Use Stereo Out fader	
	Group Master levels		Use faders assigned to Group Master in the User Assignable Layer.	
Channel Mutes (ON/OFF)	Input	ON	Set Layer to input, use [ON] buttons	[ON] buttons of paired channels and grouped mutes are recorded together
	Bus Out, Aux Send, Matrix Send		Set Layer to Master, use [ON] buttons	
	Stereo Out		Use Stereo Out [ON] button	
	Group Master On/Off		Use [ON] buttons assigned to Group Master in the User Assignable Layer.	
Pan	Input	PAN	Set Layer to input, Encoder mode to Pan, use Encoders	If Pan mode is Gang or Inverse-Gang, paired channels are recorded together.
Surround Pan	Input	SURR	Use Joystick (If a surround parameter is assigned to the Encoders, also use Encoders)	If ST LINK button on Surround Edit page is on, adjacent channels are recorded together.
EQ (F, Q, G, On/Off)	Input, Bus Out, Aux Send, Matrix Send, Stereo Out	EQ	Use SELECTED CHANNEL EQUALIZER section (If EQ parameter assigned to an Encoder, also use Encoders)	EQ of paired channels, and grouped EQs recorded together
Aux send 1–12 levels	Input	AUX	Use SELECTED CHANNEL AUX/MATRIX SEND LEVEL controls (If Layer is input and Fader mode is Aux/Mtrx, use faders. If Layer is input and Encoder mode is Aux/Mtrx, use Encoders)	Aux send levels of paired channels recorded together. (If the selected Aux Send is paired, the send level to both Aux Sends is recorded.)
Aux send 1–12 mutes	Input	AUX ON	Use SELECTED CHANNEL AUX/MATRIX SEND [ON] buttons	Aux send mutes of paired channels recorded together (If the selected Aux Send is paired, mutes for both Aux Sends recorded.)
Matrix send 1–4 levels	Bus Out, Aux Send	AUX	If Layer is Master and Fader mode is Aux/Mtrx, use faders (If Layer is Master and Encoder mode is Aux/Mtrx, use Encoders)	Matrix send levels of paired Bus Outs or Aux Sends recorded together
	Bus Out, Aux Send, Stereo Out		Use SELECTED CHANNEL AUX/MATRIX SEND controls	
Matrix send 1–4 mutes	Bus Out, Aux Send, Stereo Out	AUX ON	Use SELECTED CHANNEL AUX/MATRIX SEND [ON] buttons	Matrix send mutes of paired Bus Outs or Aux Sends recorded together
Scene recalls	—	—	Use SCENE MEMORY section or Scene Memory page	—
Library recalls	EQ, Gate, Comp, Effects, Channel	—	Use corresponding library page	—
Effect parameters (certain parameters)	Effects processors 1–8	—	Use Parameter controls 1–4 (push to punch in/out). Select the desired parameter on the Effect Edit page, then press [ENTER]	—
User Defined Plug-Ins (parameters 1–4)	Plug-Ins 1–8	—	Use Parameter controls 1–4 (push to punch in/out). Select the desired parameter on the Plug-in Edit page, then press [ENTER]	—
User Defined Remote Layers	Faders	FADER	Select User Defined Remote Layer, use faders	—
	[ON] buttons	ON	Select User Defined Remote Layer, use [ON] buttons	—
	Encoders	PAN	Select User Defined Remote Layer, use Encoder	—

## Punching In & Out Individual Parameters

During Automix rerecording, channels can be punched in and out by pressing the channel strip [AUTO] buttons. Individual parameters can be punched in and out as follows.

Parameter	Channel	OVER-WRITE	Operation	Punch In	Punch Out
Channel Levels (faders)	Input	FADER	Set Layer to input, Fader mode to Fader	Touch fader knob and adjust <sup>1</sup>	Release fader knob <sup>2</sup>
	Bus Out, Aux Send, Matrix Send		Set Layer to Master, Fader mode to fader		
	Stereo Out		Stereo Out fader		
	Group Master faders		Set the Fader mode to Fader; Set the Group Master in the User Assignable Layer.		
Pan	Input	PAN	Set Layer to input, Encoder mode to Pan	Press Encoder and adjust	Press Encoder
Surround Pan	Input	SURR	Select Input Layer and assign Surround LFE Level or Surround Pan Wheel to the Encoders	Press Encoder and adjust	Press Encoder
EQ (F, Q, G)	All channels	EQ	Turn on Auto EQ Edit In preference (see page 277). Use SELECTED CHANNEL EQUALIZER section (If EQ parameter assigned to an Encoder, also use Encoders)	Adjust control	Press [AUTO] button
EQ On/Off				Press EQ [ON] button	Press [AUTO] button
Aux send 1–12	Input	AUX	Set Layer to input, Fader mode to Aux/Mtrx	Touch fader knob and adjust <sup>1</sup>	Release fader knob <sup>2</sup>
			Set Layer to input, Encoder mode to Aux/Mtrx (Or use SELECTED CHANNEL AUX/MATRIX SEND LEVEL controls)	Press Encoder and adjust	Press Encoder
Aux send 1–12 mutes	Input	AUX ON	Set Layer to input	Press SELECTED CHANNEL AUX/ MATRIX SEND [ON] button <sup>1</sup>	Press [AUTO] button <sup>2</sup>
Matrix send 1–4 levels	Bus Out, Aux Send, Stereo Out	AUX	Set Layer to Master, Fader mode to Aux/Mtrx	Touch fader knob and adjust <sup>3</sup>	Release fader knob <sup>1</sup>
			Set Layer to Master, Encoder mode to Aux/Mtrx (Also use SELECTED CHANNEL AUX/ MATRIX SEND LEVEL controls)	Press Encoder and adjust	Press Encoder
Matrix send 1–4 mutes	Bus Out, Aux Send, Stereo Out	AUX ON	Set Layer to master	Press SELECTED CHANNEL AUX/ MATRIX SEND [ON] button <sup>1</sup>	Press [AUTO] button <sup>2</sup>
Effect parameters (certain parameters)	Effects processors 1–8	—	Select internal effects processors	Push Parameter 1–4 control, or select the parameters on the Effect Edit page, then press [ENTER]	Push Parameter 1–4 control, or select the parameters on the Effect Edit page, then press [ENTER]
User Defined Plug-Ins (parameters 1–4)	Plug-Ins 1–8	—	Select Plug-Ins	Push Parameter 1–4 control. Select the desired parameter on the Plug-in Edit page, then press [ENTER]	Push Parameter 1–4 control. Select the desired parameter on the Plug-in Edit page, then press [ENTER]
User Defined Remote Layers	Faders	FADER	Select User Defined Remote Layer	Touch fader knob and adjust <sup>1</sup>	Release fader knob <sup>2</sup>
	Encoders	PAN	Select User Defined Remote Layer	Press Encoder and adjust	Press Encoder

1. TOUCH SENSE on Fader Edit page must be TOUCH or LATCH.
2. TOUCH SENSE on Fader Edit page must be TOUCH.
3. Cannot be used to control Stereo Out to Matrix Send levels.

If during Automix recording you punch in an individual parameter by using the controls listed in the above table, even if some OVERWRITE buttons are on, only the existing data of that particular parameter will be overwritten. Likewise, when you punch out an individual parameter by using the controls listed above, only that particular parameter will be punched out.

If during Automix recording you press an [AUTO] button to punch in a channel, the existing data of all parameters for which the corresponding OVERWRITE buttons are on will be overwritten. When you press the [AUTO] button to punch out of recording, all of those parameters will be punched out.

When faders are grouped with the Fader Group Master function turned off, if the OVERWRITE FADER button is on, pressing an [AUTO] button or touching the fader knob of any fader in the group (if TOUCH SENSE on the Fader Edit page is on) puts all the corresponding channels into Record mode and all the [AUTO] button indicators light up red. The same applies to Mute (OVERWRITE ON button) and EQ (OVERWRITE EQ button) groups.

## Playing Back an Automix

So long as the Automix function is enabled, the Automix function will chase the incoming timecode and play and stop the current Automix accordingly. Playback stops automatically when the end of the Automix data is reached. Playback can be stopped manually by pressing the STOP or ABORT button on the Automix Main or Memory pages, or the AUTOMIX [ABORT/UNDO] button. Playback will stop automatically if no timecode is received for a while, for example, if the timecode source is disconnected or turned off.

If the timecode source is set to internal, use the PLAY button on the Automix Main or Memory page to start Automix playback, and the STOP button to stop it.

You can disable Automix playback on individual channels by using the channel strip [AUTO] buttons. During playback, the [AUTO] button indicators appear green. When Automix playback for an individual channel is disabled, its [AUTO] button indicator goes out.

During playback, faders move in accordance with recorded Fader events (so long as the corresponding Layer and Fader mode is selected). Fader movement can be disabled by turning off the fader motors (see page 199). Fader events can be viewed on the Fader Edit pages (see page 199).

Other events are reflected by the channel strip displays and various other displays and button indicators. Recorded events of the currently selected channel are displayed by the SELECTED CHANNEL section controls and displays.

*Warning: If the effects type is different to that which was used when the effects parameter edits were recorded, the parameter edits will not be played back. However, they are not deleted. When you rerecord effects parameter edits, it's recommended that you delete the existing effects events offline. See "Editing Events Offline" on page 209 for more information.*



## Editing Events Offline

Automix events can be edited offline on the Event Job and Event Edit pages. Offline editing can be performed only while the Automix function is stopped.

### Event Job Page

On the Event Job page, specified events on specified channels between specified in and out points can be erased, copied, moved/merged, or trimmed.

- 1 Use the **AUTOMIX [DISPLAY]** button to locate the Event Job page.

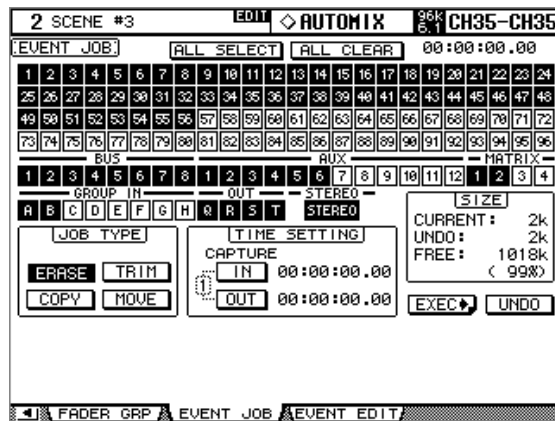

- 2 Use the cursor buttons to select the channels to edit, then press [ENTER] to set them.

You can select multiple Input Channels, Bus Outs, Aux Outs, Stereo Out, and the Fader Group Master. When you select a channel, its button is highlighted. (You can select multiple channels.)

**ALL SELECT:** The ALL SELECT button selects all channels.

**ALL CLEAR:** The ALL CLEAR button de-selects all channels.

- 3 Use the cursor buttons to select the IN and OUT parameters, then use the Parameter wheel, INC/DEC buttons or [ENTER] button to specify the edit range.

**TIME SETTING:** The IN and OUT parameters are used to specify the region of Automix data to be erased, copied, moved/merged, or trimmed. The IN and OUT points can be set on-the-fly by pressing the [ENTER] button while the IN or OUT button is selected. The captured timecode values can be edited by using the Parameter wheel or the INC/DEC buttons. Press the [ENTER] button to reset the currently selected digits to “00.” Up to eight IN and OUT timecode values can be captured and stored in the eight Capture memories. Use the cursor buttons to select the Capture memory number, and use the Parameter wheel or the INC/DEC buttons to select the Capture memories.

- 4 Use the cursor buttons to select a Job, then press [ENTER].

The following Jobs are available. Certain Jobs feature an additional parameter below the TIME SETTING section.

**ERASE:** The ERASE button erases specified Automix data.

**COPY:** The COPY button copies specified Automix data. This Job features a SOURCE section and COPY TO section (below the TIME SETTING section).

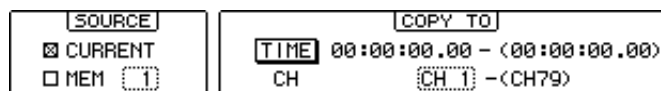

The SOURCE section enables you to select the copy source Automix. You can select CURRENT (the current Automix) or MEM (any Automix from 1 to 16).

The TIME parameter determines the point to which the specified data is copied. The number in parentheses on the right indicates the end point of the copy destination. You can set the TIME parameter on-the-fly by selecting the TIME button, then pressing [ENTER]. You can edit the captured timecode value using the Parameter wheel or INC/DEC buttons. Press [ENTER] to reset the currently-selected digit to “00.”

The CH parameter specifies the channel to which the specified data will be copied. The number of destination channels depends on the specified number of copy source channels. For example, if Input Channels 1 through 8 are specified as the source, then the number of destination channels will be eight (8). Destination channels are contiguous and only the first channel in the range can be specified. The number in parentheses on the right indicates the last channel in the copy destination.

You cannot copy from Input Channels to Output Channels. Also, even within Output Channels, you cannot copy between Aux and Bus channels.

**TRIM:** The TRIM button trims the specified Automix data. This Job includes a TRIM EDIT section below the TIME SETTING section.

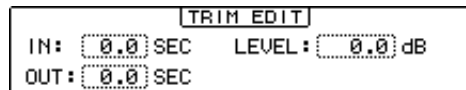

The IN parameter determines the amount of time required for the faders to achieve the specified trim amount. The OUT parameter determines the amount of time required for the faders to return to the previous levels. The LEVEL parameter specifies the fader trim amount in the range of -96 dB to +96 dB.

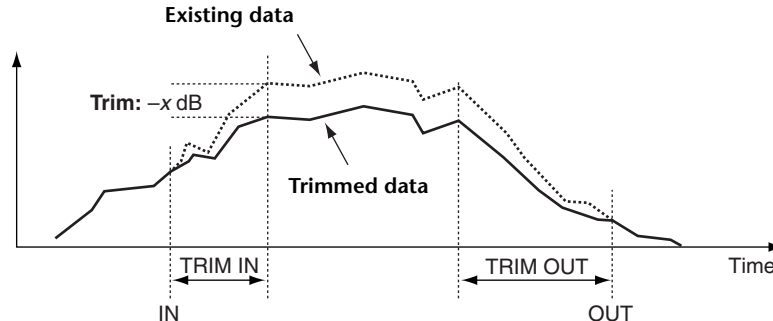

**MOVE/MERGE:** This Job features a SOURCE section and a MOVE TO (MERGE TO) section below the TIME SETTING section. The function of this button changes depending on the SOURCE section setting. If you select CURRENT (current Automix) in the SOURCE section, this button becomes the MOVE button, which enables you to move the specified range of Automix data to another position. If you select MEM (Automix memories 1–16) in the SOURCE section, this button becomes the MERGE button, which enables you to merge the specified range of Automix data with other Automix data.

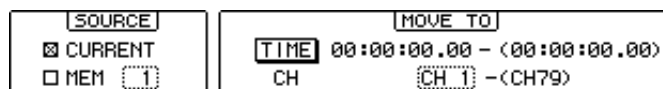

The SOURCE section enables you to select the move/merge source Automix. You can select CURRENT (the current Automix) or MEM (any Automix from 1 to 16).

The TIME parameter determines the point to which the specified data is moved or merged. The number in parentheses on the right indicates the end point of the move/merge destination. You can set the TIME parameter on-the-fly by selecting the TIME button, then pressing [ENTER]. You can edit the captured timecode value using the Parameter wheel or the INC/DEC buttons. Press the [ENTER] button to reset the currently-selected digit to “00.”

The CH parameter specifies the channel to which the specified data will be moved or merged. The number of destination channels depends on the number of move/merge source channels specified. For example, if Input Channels 1 through 8 are specified as the source, then the number of destination channels will be eight (8). Destination channels are contiguous and only the first channel in the range can be specified. The number in parentheses on the right indicates the last channel of the move/merge destination.

You cannot move or merge from Input Channels to Output Channels. Also, even within Output Channels, you cannot move or merge between Aux and Bus channels.

**5 Use the cursor buttons to select the EXEC button, then press [ENTER].**

The PARAMETERS window appears, which enables you to select the parameters to be edited, and to perform the selected Job.

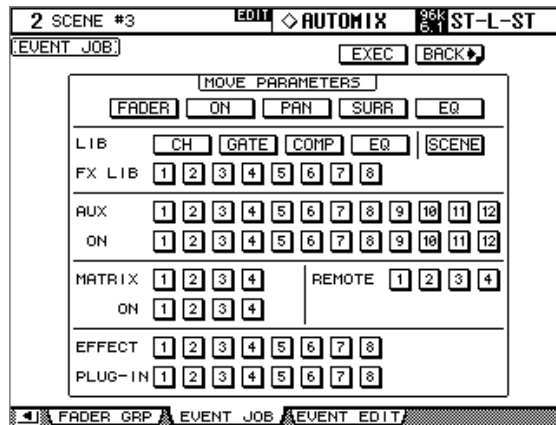

When you select a parameter, its button is highlighted. You can specify multiple parameters. Double-clicking a non-highlighted parameter button will display a message confirming that you wish to highlight all parameter buttons. Double-clicking a highlighted parameter button will display a message that you wish to unhighlight all parameter buttons.

These buttons correspond to the following parameters:

Button		Events
FADER		Channel Fader events (Inputs Channels, Bus Out masters, Aux Send masters, Matrix Send masters, Group master levels, and the Stereo Out)
ON		Channel Mute events, and Group master ON
PAN		Input Channel pan events
SURR		Input Channel surround pan, LFE level, DIV parameter events, and RDIV parameter events
EQ		Channel EQ events
LIB	CH	Channel library recall events
	GATE	Gate library recall events
	COMP	Comp library recall events
	EQ	EQ library recall events
	SCENE	Scene recall events
FX LIB	1–8	Effects library recall events of each internal effects processor
AUX	1–12	Level events of each Aux Send
ON	1–12	Mute events of each Aux Send
MATRIX	1–4	Level events of each Matrix Send
ON	1–4	Mute events of each Matrix Send
REMOTE	1–4	User Defined Remote Layer events
EFFECT	1–8	Parameter events for each internal effects processor
PLUG-IN	1–8	Parameter events for each Plug-In

**6 Use the cursor buttons to select the EXEC button, then press [ENTER].**

When the confirmation message appears, select YES to execute the Job.

**BACK:** Select this button to return to the previous page without executing the Job.

## Event Edit Page

On the Event Edit page, you can edit, duplicate, delete, and insert new events.

- 1 Use the **AUTOMIX [DISPLAY]** button to locate the Event Edit page.

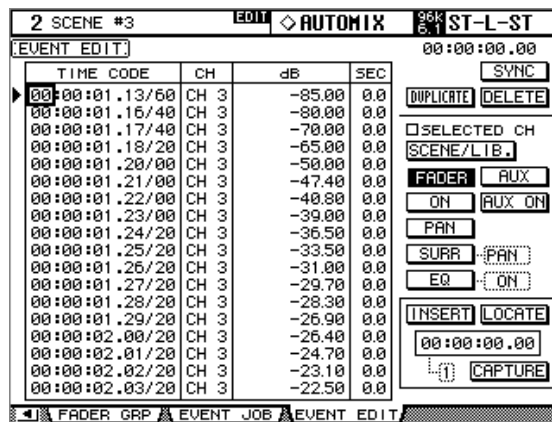

- 2 Use the cursor buttons to select the parameters, and use the Parameter wheel, INC/DEC buttons, and [ENTER] button to set them.

**Event list:** Automix events are listed in chronological order. The type of events listed depends on the Event select buttons. Use the cursor buttons to select event parameters. While the cursor is on the SYNC, DUPLICATE, DELETE, SELECTED CH, or Event select buttons, you can use the Parameter wheel or the INC/DEC buttons to scroll the list. While the cursor is inside the event list, you can use these controls to edit event parameters. The triangular cursor at the left side of the list indicates the currently selected event. When an event's timecode value is edited, the list is resorted automatically.

**SYNC button:** This button is used to synchronize the list to the current timecode position. When pressed, events closest to the current timecode position are displayed. This function can be used during Automix playback.

**DUPLICATE button:** This button is used to duplicate events. Use the Parameter wheel to select an event, select the DUPLICATE button, and then press [ENTER]. A duplicate event is inserted below the currently selected event. If there are no events in the list, you can use this button to insert a new event of the type specified by the Event select buttons.

**DELETE button:** This button is used to delete events. Use the Parameter wheel to select an event, select the DELETE button, and then press [ENTER].

**SELECTED CH:** When this option is on, only events of the currently selected channel are displayed. All Scene recall and effects library recall events are displayed regardless of this option. For paired channels, only events of the currently selected channel are displayed.

**Event select buttons:** These buttons are used to select the type of events to be displayed in the event list.

Button	Events Listed	List Format
<b>SCENE/LIB</b>	Library and Scene recall events	TIME CODE, CH, SCENE/LIB
<b>FADER</b>	Channel faders (Inputs Channels, Bus Out masters, Aux Send masters, Matrix Send masters, Group master levels, and the Stereo Out)	TIME CODE, CH, dB, SEC
<b>ON</b>	Channel Mutes (ON/OFF)	TIME CODE, CH, ON/OFF
<b>PAN</b>	Pan	TIME CODE, CH, L-C-R
<b>SURR-PAN</b>	Surround pan	TIME CODE, CH, SURR
<b>SURR-LFE</b>	Surround LFE	TIME CODE, CH, dB
<b>SURR-DIV</b>	Surround DIV	TIME CODE, CH, DIV
<b>SURR-RDIV</b>	Surround RDIV	TIME CODE, CH, DIV
<b>EQ-ON</b>	EQ ON/OFF	TIME CODE, CH, ON/OFF
<b>EQ-FREQ</b>	EQ Frequency	TIME CODE, CH, BAND/Hz
<b>EQ-Q</b>	EQ Q	TIME CODE, CH, BAND/Q
<b>EQ-GAIN</b>	EQ Gain	TIME CODE, CH, BAND/dB
<b>AUX</b>	Aux/matrix Send 1–12 levels	TIME CODE, CH, AUX, dB
<b>AUX ON</b>	Aux/matrix Send 1–12 mutes	TIME CODE, CH, AUX, ON/OFF

**INSERT button:** This button is used to insert new events. Use the Event select buttons to select the type of event that you want to insert. Use the Captured timecode counter to specify the point at which you want to insert the new event. Select the INSERT button, and then press [ENTER].

**LOCATE button:** This button is used to locate events at the Capture memory display position.

**Capture memory display:** This displays the captured timecode position. The captured timecode values can be edited by using the Parameter wheel or the INC/DEC buttons. Press the [ENTER] button to reset the currently selected digits to “00.”

**CAPTURE button:** This button is used to capture the current timecode position. Up to eight timecode values can be captured and stored in the eight Capture memories. Use the cursor buttons to select the Capture memory number, and use the Parameter wheel or the INC/DEC buttons to select the Capture memories. Capture memories can be selected even while the CAPTURE, LOCATE, or INSERT button is selected.

If the Auto Inc TC capture preference is on (see page 277), Capture memories increment automatically each time a timecode position is captured.

If the Link Capture & Locate Memory preference is on (see page 277), the eight Capture memories are linked to the eight Locate memories so that, for example, edits made to Capture memory #1 are reflected on Locate memory #1, and vice versa.

# 18 MIDI

## MIDI & the DM2000

The DM2000 supports the following MIDI messages:

- Program Changes for recalling Scenes (see page 218)
- Control Changes for real-time parameter control (see page 219)
- System Exclusive Parameter Changes for real-time parameter control (see page 219)
- MIDI Note On/Off for Freeze effect etc. (see page 325)
- Bulk Dump for transmitting Scene, library, and setup data (see page 220)
- MTC and MIDI Clock for Automix synchronization (see page 201)
- MMC for external machine control (see page 256)
- User Defined Plug-Ins transmit user-specified MIDI data when Parameter controls 1–4 are operated (see page 179)
- User Defined Remote Layers transmit user-specified MIDI data when the channel strip faders, Encoders, and [ON] buttons are operated (see page 253)
- Predefined Remote Layers for controlling popular DAWs (Digital Audio Workstations), including Pro Tools (see page 221)

## MIDI I/O

The DM2000 features four types of interface for transmitting and receiving MIDI data:

- Standard MIDI ports
- TO HOST USB port
- TO HOST SERIAL port
- SLOT1 (for use with an optional mLAN I/O Card installed in Slot #1)

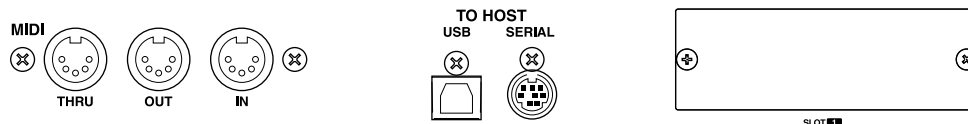

TO HOST SERIAL and TO HOST USB are multiport interfaces, with eight ports each.

When the DM2000 receives MIDI data via any of these interfaces, the MIDI indicator appears on the display (see page 52).

If you are connecting a Windows computer to the TO HOST USB or TO HOST SERIAL port, you must install and use the YAMAHA CBX Driver for Windows and the YAMAHA USB Driver for Windows, which are included on the supplied CD-ROM.

If you plan to connect a Macintosh computer to the TO HOST USB port, you must install and use the YAMAHA USB Driver for Macintosh, or the YAMAHA USB Driver for MacOS X. If you are using MacOS 8.6–9.2.2, you must install OMS 2.3.3 in the Macintosh.

If you plan to connect a Macintosh computer running MacOS 8.6–9.2.2 to the TO HOST SERIAL port on the DM2000, you must install OMS 2.3.3 in the Macintosh.

## MIDI Port Setup

MIDI ports are configured as follows.

- 1 Use the **DISPLAY ACCESS [SETUP]** button to locate the **MIDI/TO HOST Setup** page.

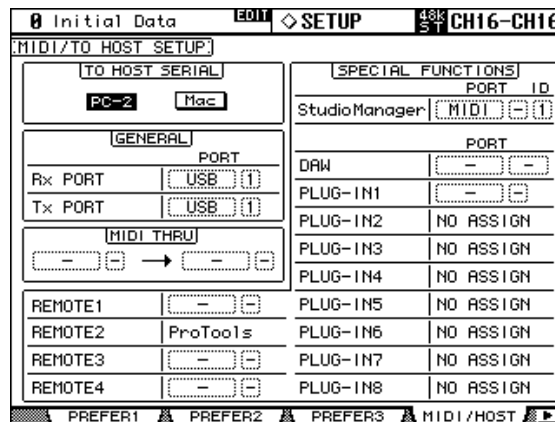

- 2 Use the cursor buttons to select the parameters, and use the Parameter wheel, INC/DEC buttons, and [ENTER] button to set them.

**TO HOST SERIAL:** These buttons are used to configure the TO HOST SERIAL port for use with either a Mac or PC.

*Caution: When a PC is connected to the TO HOST SERIAL port, do not set this to Mac because your PC may crash.*

**GENERAL:** These parameters are used to select ports for general MIDI data transmission and reception, including Program Changes for recalling Scenes, Control Changes for real-time parameter control, and Note On/Off for use with the Freeze effect. Available ports include: MIDI, SERIAL 1–8, USB 1–8, and SLOT1.

**MIDI THRU:** These parameters allow you to route the incoming MIDI data from one port through to another port. Available ports include: MIDI, SERIAL 1–8, USB 1–8, and SLOT1.

**REMOTE1–4:** These parameters are used to select ports for the Remote Layers. Available ports include: MIDI, SERIAL 1–8, USB 1–8, and SLOT1. If Pro Tools is selected as the target for a Remote Layer, “Pro Tools” is displayed here and no settings can be made.

**Studio Manager:** These parameters are used to select a port for use with the Studio Manager software and to assign the DM2000 an ID from 1 to 8. Available ports include: MIDI, SERIAL 1–8, USB 1–8, and SLOT1. See the Studio Manager documentation for more information.

**DAW:** These parameters are used to select ports for use with DAWs. Since four ports are required to control DAWs, ports are selected in groups of four, as follows: 1–4, 2–5, 3–6, 4–7, 5–8. Available ports include: SERIAL, USB, and SLOT1.

**PLUG-IN1–8:** These parameters are used to select ports for use with the Plug-Ins. If a Waves Plug-In card is installed in a Slot, the number of that Slot is displayed and no settings can be made. If the Plug-In target is set to USER DEFINED, you can select a port from MIDI, SERIAL 1–8, USB 1–8, or SLOT1. Ports for User Defined Plug-Ins can also be set on the Plug-In Setup page (see page 180).

*Note: Some functions cannot share ports. If you try to assign a port that’s already assigned to such a function, the message “Change Port?” appears. If you select YES, the port will be assigned to the selected function and the previously assigned function will be set to “NO ASSIGN.”*



## MIDI Channel Setup

MIDI Channels for reception and transmission are specified as follows.

- 1 Use the **DISPLAY ACCESS [MIDI]** button to locate the **MIDI Setup** page.

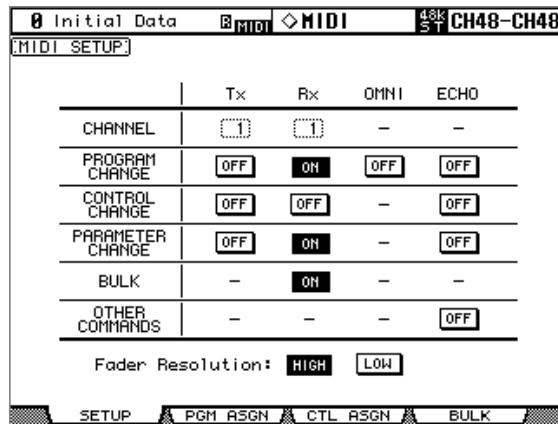

- 2 Use the cursor buttons or Parameter wheel to select the parameters, and use the INC/DEC buttons or [ENTER] button to set them.

Select MIDI channels for transmission and reception in the CHANNEL row, and turn the transmission and reception of each MIDI message on or off using the buttons in the parameter rows from PROGRAM CHANGE to OTHER COMMANDS.

### CHANNEL

This parameter row enables you to specify MIDI Channels for MIDI message transmission and reception. The following parameters are available in this row:

**Tx:** This parameter box specifies a MIDI Transmit Channel.

**Rx:** This parameter box specifies a MIDI Receive Channel.

### PROGRAM CHANGE

This parameter row enables or disables transmission and reception of Program Changes.

**Tx ON/OFF:** Transmission of Program Change messages is enabled or disabled.

**Rx ON/OFF:** Reception of Program Change messages is enabled or disabled.

**OMNI ON/OFF:** When this button is turned on, Program Changes on all MIDI Channels are received regardless of the CHANNEL row settings.

**ECHO ON/OFF:** This button determines whether Program Change messages received at the MIDI IN port are echoed through to the MIDI OUT port.

### CONTROL CHANGE

This parameter row enables or disables transmission and reception of Control Changes.

**Tx ON/OFF:** Transmission of Control Change messages is enabled or disabled.

**Rx ON/OFF:** Reception of Control Change messages is enabled or disabled.

**ECHO ON/OFF:** This button determines whether Control Change messages received at the MIDI IN port are echoed through to the MIDI OUT port.

### PARAMETER CHANGE

This parameter row enables or disables transmission and reception of Parameter Changes.

**Tx ON/OFF:** Transmission of Parameter Change messages is enabled or disabled.

**Rx ON/OFF:** Reception of Parameter Change messages is enabled or disabled.

**ECHO ON/OFF:** This button determines whether Parameter Change messages received at the MIDI IN port are echoed through to the MIDI OUT port.

**BULK**

This parameter row enables or disables reception of Bulk Dump data.

**Rx ON/OFF:** Reception of Bulk Dump data is enabled or disabled.

**OTHER COMMANDS**

**ECHO ON/OFF:** This button determines whether other MIDI messages received at the MIDI IN port are echoed through to the MIDI OUT port.

**Fader Resolution**

**HIGH/LOW:** This parameter specifies the resolution of the value output when you operate the DM2000's faders. To transfer fader value data between two cascaded DM2000s, or to record the DM2000 operation to or play it back from a sequencer, select the HIGH button. When the LOW button is selected, the fader resolution switches to 256 steps.

## Assigning Scenes to Program Changes

DM2000 Scenes can be assigned to MIDI Program Changes for remote recall. When a Scene is recalled on the DM2000, the assigned Program Change number is transmitted. If that Scene is assigned to more than one Program Change, the lowest Program Change is transmitted. Likewise, when a Program Change message is received, the assigned Scene is recalled. You must set the MIDI Setup parameters in order to transmit and receive Program Change messages (see page 217).

Initially, Scenes 1 through 99 are assigned sequentially to Program Changes 1 through 99. Scene #0 is assigned to Program Changes #100. A Scene to Program Change assignment table, listing initial assignments and with space to note user assignments, is provided on page 352. This table can be stored to an external MIDI device, such as a MIDI data filer, by using MIDI Bulk Dump (see page 220), or stored to SmartMedia (see page 271).

- 1 Use the **DISPLAY ACCESS [MIDI]** button to locate the **Program Change Assign Table** page.

PGM CHG	SCENE NO./TITLE
10 =	10.[ No Data! ]
9 =	9.[ No Data! ]
8 =	8.[ No Data! ]
7 =	7.[ No Data! ]
6 =	6.SCENE #6
5 =	5.SCENE #5
No. 4 =	4.SCENE #4
3 =	3.SCENE #3
2 =	2.SCENE #2
1 =	1.SCENE #1

- 2 Use the cursor buttons to select the **PGM CHG.** column, and use the **Parameter wheel** or **INC/DEC** buttons to select the **Program Changes**.
- 3 Use the cursor buttons to select the **SCENE No./TITLE** column, and use the **Parameter wheel** or **INC/DEC** buttons to select **Scenes**.

You can initialize the Scene to Program Change assignment table by selecting the **INITIALIZE** button, and then pressing **[ENTER]**.

## Assigning Parameters to Control Changes

DM2000 parameters can be assigned to MIDI Control Changes for real-time control. When a parameter is adjusted on the DM2000, the assigned Control Change message is transmitted. Likewise, when a Control Change message is received, the assigned DM2000 parameter is set. You must set the MIDI Setup parameters in order to transmit and receive Control Change messages (see page 217).

A Parameter to Control Change assignment table, listing the initial assignments, is provided on page 353. This table can be stored to an external MIDI device, such as a MIDI data file, by using MIDI Bulk Dump (see page 220), or stored to SmartMedia (see page 271).

- 1 Use the **DISPLAY ACCESS [MIDI]** button to locate the **Control Change Assign Table** page.

No. (CH)	PARAMETER		
12 ( 1 )	FADER H	CHANNEL	INPUT 12
11 ( 1 )	FADER H	CHANNEL	INPUT 11
10 ( 1 )	FADER H	CHANNEL	INPUT 10
9 ( 1 )	FADER H	CHANNEL	INPUT 9
8 ( 1 )	FADER H	CHANNEL	INPUT 8
7 ( 1 )	FADER H	CHANNEL	INPUT 7
6 ( 1 )	FADER H	CHANNEL	INPUT 6
5 ( 1 )	FADER H	CHANNEL	INPUT 5
4 ( 1 )	FADER H	CHANNEL	INPUT 4
3 ( 1 )	FADER H	CHANNEL	INPUT 3
2 ( 1 )	FADER H	CHANNEL	INPUT 2
1 ( 1 )	FADER H	CHANNEL	INPUT 1
0 ( 1 )	NO ASSIGN		

- 2 Use the cursor buttons to select the **MODE TABLE** button, and press [ENTER].  
In TABLE mode, when DM2000 parameters are adjusted, MIDI Control Change messages are transmitted in accordance with the assignments on this page. In NRPN mode, when DM2000 parameters are adjusted, predefined NRPNs (Non Registered Parameter Number) are transmitted.
- 3 Use the cursor buttons to select the **No. (CH)** column, and use the **Parameter wheel** or **INC/DEC** buttons to select the **Control Changes**.
- 4 Use the cursor buttons to select the three **PARAMETER** columns, and use the **Parameter wheel** or **INC/DEC** buttons to select the parameters.

Parameters with more than 128 steps require two or more Control Change messages for MIDI transmission and reception. Certain Delay parameters and the faders are divided into L and H parameters. Delay Time parameters are divided into LOW, MID, and HIGH parameters. For accurate transmission, all parameters (e.g., both L and H for faders) must be assigned to individual Control Changes.

You can initialize the Parameter to Control Change assignment table by selecting the **INITIALIZE** button, and then pressing [ENTER].

## Controlling Parameters by Using Parameter Changes

DM2000 parameters can be controlled in real time by using Parameter Change messages, which are System Exclusive messages. When a parameter is adjusted on the DM2000, a Parameter Change message is transmitted. Likewise, when a Parameter Change message is received, a DM2000 parameter is adjusted. See “MIDI Data Format” on page 369 for detailed information. You must set the MIDI Setup parameters in order to transmit and receive Parameter Change messages (see page 217).

## Using Bulk Dump

DM2000 data can be stored to an external MIDI device, such as a MIDI data filer, by using MIDI Bulk Dump.

- 1 Use the **DISPLAY ACCESS [MIDI]** button to locate the Bulk Dump page.

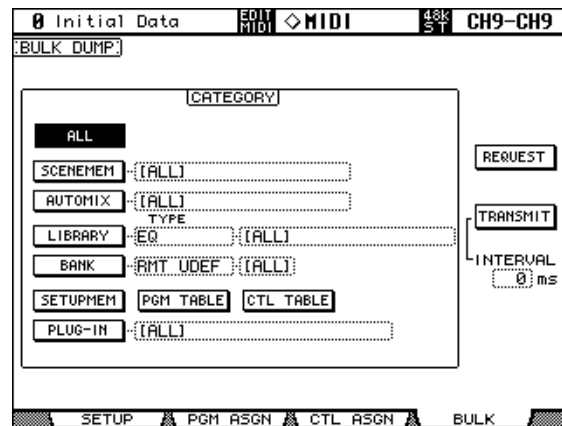

- 2 To transmit data, use the **CATEGORY** parameters to select the type of data you want to transmit, select the **TRANSMIT** button, and then press **[ENTER]**.

The **INTERVAL** parameter sets the interval between data packets during transmission.

The **CATEGORY** parameters can be set as follows:

**ALL:** All data.

**SCENE MEM:** ALL Scenes, individual Scenes, or current (i.e., the Edit buffer).

**AUTOMIX:** ALL Automixes, individual Automixes, or the current Automix.

**LIBRARY:** The following libraries: EQ, Gate, Comp, Channel, Effects, GEQ, Bus to Stereo, Input Patch, Output Patch, Surround Monitor. For each library you can specify ALL user memories, individual user memories, and for the Bus to Stereo, Input Patch, Output Patch, Surround Monitor libraries you can also specify the current settings.

**BANK:** User Defined Remote Layer banks (RMT UDEF), User Defined Plug-Ins banks (PLUG UDEF), User Defined Keys banks (KEYS UDEF), or the USER ASSIGNABLE LAYER banks (USR LAYER). For each item you can specify ALL or individual banks.

**SETUP MEM:** DM2000 setup data (i.e., system settings).

**PGM TABLE:** Scene to MIDI Program Change table. See “Assigning Scenes to Program Changes” on page 218.

**CTL TABLE:** Parameter to MIDI Control Change table. See “Assigning Parameters to Control Changes” on page 219.

**PLUG-IN:** The settings of any installed Y56K cards. You can specify ALL Slots or Slots 4–6 individually.

- 3 You can also transmit DM2000 data via a MIDI cable. To receive data, use the **CATEGORY** parameters to select the type of data you want to receive, select the **REQUEST** button, then press **[ENTER]**.

---

# 19 Pro Tools Remote Layer

---

The DM2000 features a Remote Layer target especially designed for controlling Pro Tools. If an optional MB2000 Peak Meter Bridge is installed, Pro Tools channel levels are displayed by the meters, and timecode is displayed on the TIME CODE counter.

## Configuring Windows Computers

### 1 Connect your PC.

The DM2000 can be connected to your Windows PC by connecting the TO HOST SERIAL port to a suitable RS232 serial port on your PC, or by connecting the TO HOST USB port to a USB port on your PC. If you use the TO HOST SERIAL port, make sure that the TO HOST SERIAL parameter on the MIDI/TO HOST Setup page is set to PC-2 (see page 216).

### 2 Install the necessary drivers.

Once your PC is connected, you'll need to install the TO HOST SERIAL or TO HOST USB drivers included on the DM2000 CD-ROM.

## Configuring Macintosh Computers (MacOS 8.6 to 9.2.2)

### 1 Connect your Mac.

The DM2000 can be connected to your Mac by connecting the TO HOST SERIAL port to either the Printer or Modem port on your Mac, or by connecting the TO HOST USB port to a USB port on your Mac. If you use the TO HOST SERIAL port, make sure that the TO HOST SERIAL parameter on the MIDI/TO HOST Setup page is set to Mac (see page 216).

### 2 Install OMS.

The DM2000 communicates with Pro Tools via OMS (Open Music System) software. If you already have OMS installed on your Mac, there's no need to install it again and you can move on to the next section. If you don't already have OMS installed, it's included on the DM2000 CD-ROM. Refer to the OMS documentation included on the DM2000 CD-ROM for more information on installing.

### 3 Install Yamaha USB MIDI driver 1.04 or later.

If you are using the TO HOST USB port, you must also install the Yamaha USB MIDI driver included on the DM2000 CD-ROM. See the included documentation for more information.

## Configuring Macintosh Computer (MacOS X)

### 1 Connect the DM2000 TO HOST USB port to a USB port on your Mac.

### 2 Install the Yamaha USB MIDI Driver for MacOS X on the computer.

## Configuring the DM2000

- 1 Use the **DISPLAY ACCESS [SETUP]** button to locate the **MIDI/TO HOST Setup** page, and use the **DAW** parameter to specify the port to which Pro Tools is connected.

See “MIDI Port Setup” on page 216 for more information.

- 2 Use the **DISPLAY ACCESS [REMOTE]** button to locate the **Remote** pages, and assign Pro Tools to a **Remote Layer**.

See “Assigning Targets to Remote Layers” on page 253 for more information.

- 3 Use the **LAYER [REMOTE]** buttons to select the **Pro Tools Remote Layer**.

When the Pro Tools Remote Layer is selected, the DM2000’s control surface controls Pro Tools, not the DM2000. In order to control the DM2000, you need to select an Input Channel Layer or the Master Layer. Audio mixing on the Input and Master Layers, and Automix continues while the Pro Tools Layer is selected.

## Configuring Pro Tools

Pro Tools needs to be configured as follows. For more information, see your Pro Tools documentation.

- 1 **Launch Pro Tools.**
- 2 **If you are using MacOS 8.6 - 9.2.2, choose OMS Studio Setup from the Setups menu, and configure OMS as necessary.**

This screen shot shows the Yamaha USB MIDI driver with eight ports. An OMS-compatible device profile for the DM2000 is included on the DM2000 CD-ROM. See the included documentation for more information.

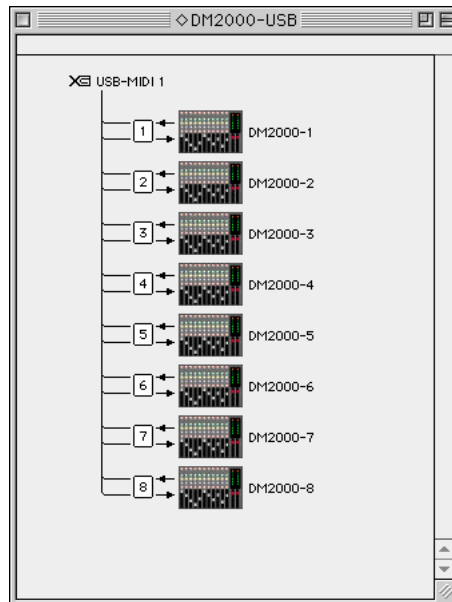

- 3 **Choose Peripherals from the Setups menu.**

- 4 When the Peripherals window appears, click the MIDI Controllers button.

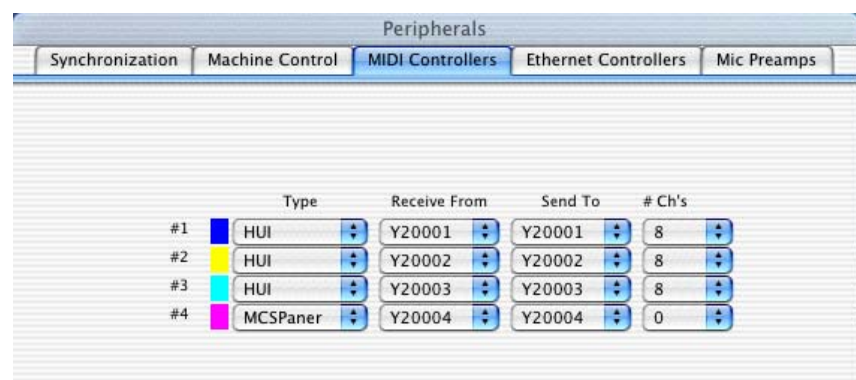
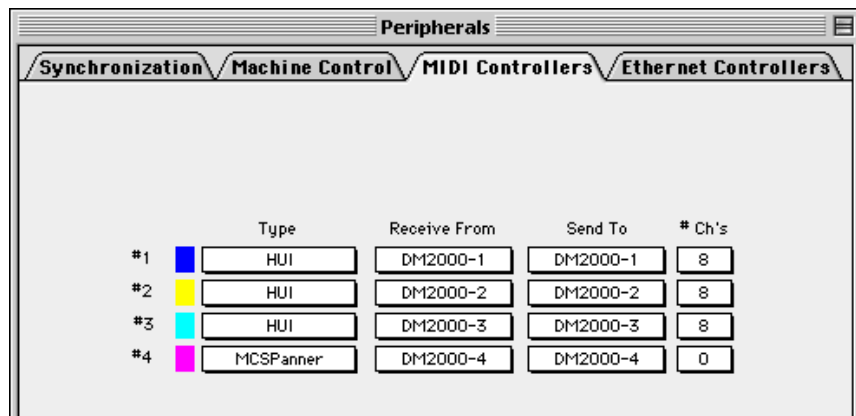

- 5 Select HUI as the Type of controller for #1–#3, and select MCS PANNER for #4 to enable use of the Joystick.
- 6 Select the Receive From and Send To ports, and then click OK.

The DM2000 can emulate up to three typical 8-channel Pro Tools MIDI controllers. A single MIDI port is required for every eight channels. So, you must configure MIDI Controller #1 to use channels 1 through 8, MIDI Controller #2 to use channels 9 through 16, and MIDI Controller #3 to use channels 17 through 24.

## Control Surface Operation with the Pro Tools Remote Layer

This section explains the operation of the DM2000 control surface when the Pro Tools Remote Layer is selected. DM2000 buttons and controls are referred to by the names printed on the DM2000 with the name of the corresponding Pro Tools function in parenthesis. For example, “Press the MATRIX SELECT [MATRIX 1] (DEFAULT) button.” In keyboard shortcuts, the Pro Tools function names are left out for simplification.

### Display

This is the Pro Tools Remote Layer page, the various sections of which are explained below.

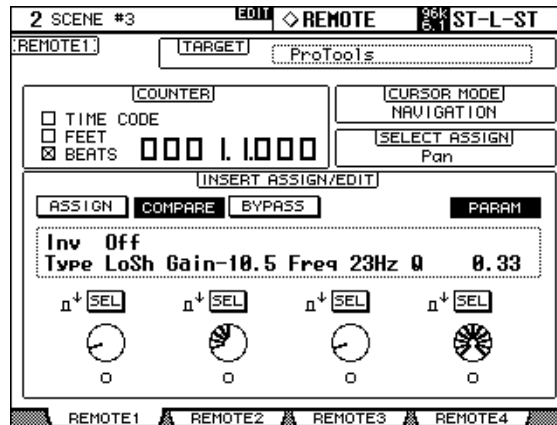

#### TARGET

This parameter cannot be changed here. To change the target for this Layer, you must first select another Layer, and then use the DISPLAY ACCESS [REMOTE] button to locate the Remote page for this Layer. See “Assigning Targets to Remote Layers” on page 253 for more information.

#### COUNTER

This counter works in unison with the timecode counter in Pro Tools. The display format is specified in Pro Tools. The three check boxes indicate the currently selected format, as follows:

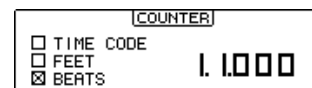

**TIME CODE:** Pro Tools timecode format set to “Time Code.”

**FEET:** Pro Tools timecode format set to “Feet:Frames.”

**BEATS:** Pro Tools timecode format set to “Bars:Beats.”

When the Pro Tools timecode format is set to “Minutes:Seconds” or “Samples,” no check boxes are selected.

#### CURSOR MODE

The currently selected Cursor mode is displayed here: NAVIGATION, ZOOM, or SELECT. Cursor modes are selected by using the [INC] (CURSOR MODE) button.

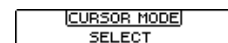

#### SELECT ASSIGN

This indicates the current function of the Encoders. For example, Pan (PanR), SndA, SndB, SndC, SndD, or SndE.





**INSERT ASSIGN/EDIT**

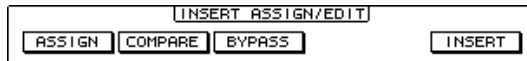

**ASSIGN:** This indicator works in unison with the EFFECTS/PLUG-INS [5] (ASSIGN) button indicator. See “Assigning Inserts/Plug-ins” on page 244 for more information.

**COMPARE:** This indicator works in unison with the EFFECTS/PLUG-INS [6] (COMPARE) button indicator. See “Editing Plug-ins” on page 245 for more information.

**BYPASS:** This indicator works in unison with the EFFECTS/PLUG-INS [7] (BYPASS) button indicator. See “Editing Plug-ins” on page 245 and “Bypassing Individual Plug-ins” on page 246 for more information.

**INSERT:** This indicator works in unison with the EFFECTS/PLUG-INS [8] (INSERT/PARAM) button indicator. See “Editing Plug-ins” on page 245 for more information.

**INSERT/PARAM Display**



This section displays mainly insert and plug-in-related information, although other messages are also displayed here.

**Encoder Display**



This section displays information about the Parameter controls 1–4. The SEL indicators show the on/off status of the Parameter control push-switches. The rotary control indicators show the positions of the Parameter controls. The “O” symbol below each Parameter control shows the automation status for each Parameter control.

**Channel Strips**

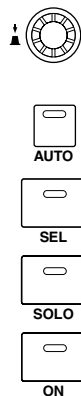

DM2000 channel strips correspond to Pro Tools channels from left to right, with the leftmost Pro Tools channel being handled by DM2000 channel strip #1. You can change the order of channel strips by dragging the channel select buttons in Pro Tools, in which case the DM2000 automatically reorders its channel strips. By using certain USER DEFINED KEYS, Pro Tools channels can be scrolled individually (see page 234), or in banks of 24 (see page 234).

### Encoders & Push-Switches

The Encoders are used to set pan and send levels and select I/O assignments. The Encoder push-switches are used to mute sends, reset send levels and panpots, and confirm I/O assignments. Their exact operation depends on the currently selected Encoder mode, as shown in the following table.

Encoder Mode	Encoder	Push-switches
[PAN]	Pan (see page 241)	Reset pan (see page 247)
[SEND LEVEL]	Send levels (see page 243)	Mute sends (see page 243) Send pre/post (see page 242) Reset send levels (see page 247)
[INPUT]	Select input source (see page 239)	Confirm selection
[OUTPUT]	Select output destination (see page 240)	
[SEND ASSIGN]	Select send destination (see page 242)	

### [AUTO] buttons

These buttons are used in conjunction with the AUTOMIX section to set the Automation mode of each channel. See “Setting the Automation Mode” on page 250 for more information.

### [SEL] buttons

These buttons are used to select channels (see page 239), to select inserts (see page 245), and to bypass inserts (see page 246).

### [SOLO] buttons

These buttons are used to solo channels. See “Soloing Channels” on page 241 for more information.

### [ON] buttons

These buttons are used to mute channels. See “Muting Channels” on page 241 for more information.

### Faders

The faders are used to set channel levels (see page 240), or to set send levels in Flip mode (see page 243).

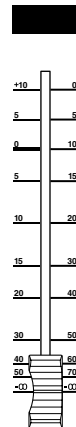

## Channel Strip Displays



Audi

The fluorescent channel strip displays graphically display the value of the parameter currently assigned to the Encoders. The minimum and maximum segments do not work with the Pro Tools Remote Layer. Channel strip displays also display Pro Tools channel names in an abbreviated form. Various other information is also displayed here and this is explained in the relevant sections.

### Selected Channel



The channel strip borders of currently selected channels light up like this.

### Fader Touch Sense



When fader knobs are touched, the corresponding Touch Sense indicators light up like this.

### Insert Indicator



The INS indicator shows whether a channel's plug-ins are on or off.

### Pan Display



Hard left

(▲ indicates center position)



Other position



Center

(■ indicates at center)



Hard right

### Send Level



Minimum



Other value



Maximum

## MATRIX SELECT Section

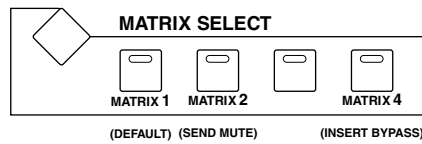

### [MATRIX 1] (DEFAULT) button

This button is used in conjunction with other controls to reset faders, panpots, sends, and plug-ins to their default values. See “Resetting Faders, Sends, Panpots & Plug-ins” on page 247 for more information.

### [MATRIX 2] (SEND MUTE) button

This button is used in conjunction with the Encoder push-switches to mute sends. See “Muting Sends” on page 243 for more information.

### [MATRIX 4] (INSERT BYPASS) button

This button is used in conjunction with other controls to bypass plug-ins. See “Bypassing Individual Plug-ins” on page 246 for more information.

## AUX SELECT Section

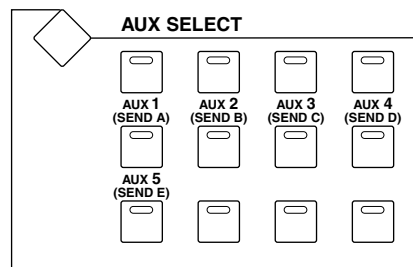

AUX SELECT [AUX 1]–[AUX 5] buttons are used to select sends A–E. The button indicator of the currently selected send lights up.

## ENCODER MODE Section

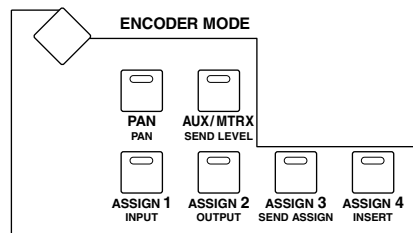

### [PAN] (PAN) button

When this button is pressed, the Encoders work as channel panpots. Its indicator lights up when it’s pressed. See “Panning Channels” on page 241 for more information.

### [AUX/MTRX] (SEND LEVEL) button

When this button is pressed, the Encoders work as send level controls. Its indicator lights up when it’s pressed, and send A is selected automatically. If the Encoders are currently set to control pan, its indicator lights automatically when one of the AUX SELECT [AUX 1]–[AUX 5] (SEND A–E) buttons is pressed.

**[ASSIGN 1] (INPUT) button**

This button is used in conjunction with other controls to set channel input sources. See “Assigning Inputs to Channels” on page 239 for more information.

**[ASSIGN 2] (OUTPUT) button**

This button is used in conjunction with other controls to set channel output destinations. See “Assigning Outputs to Channels” on page 240 for more information.

**[ASSIGN 3] (SEND ASSIGN) button**

This button is used in conjunction with other controls to set send destinations. See “Assigning Send Destinations” on page 242 for more information.

**[ASSIGN 4] (INSERT) button**

This button determines the operation of the [SEL] buttons. When its indicator is off, [SEL] buttons select channels (see page 239). When its indicator is on, they select inserts/plugin-ins (see page 245).

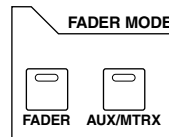
**FADER MODE Section****[FADER] & [AUX/MTRX] buttons**

These buttons are used to select Flip mode, in which faders, Encoders, and [ON] buttons can be used to control sends. See “Flip Mode” on page 243 for more information.

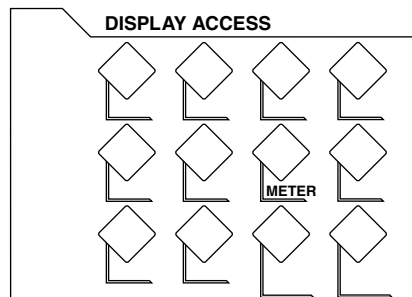
**DISPLAY ACCESS Section****[METER] button**

This button is used to reset the meter clip indicators and peak hold indicators.

## EFFECTS/PLUG-INS Section

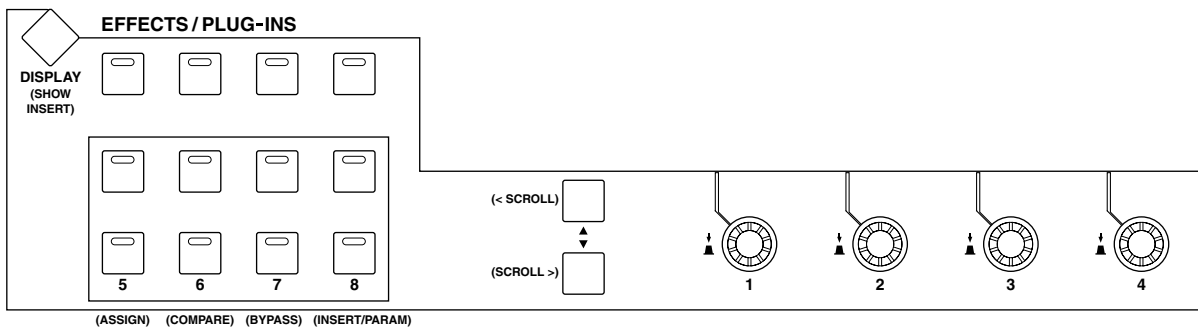
**[DISPLAY] (SHOW INSERT) button**

This button is used to open and close plug-in windows.

**[5] (ASSIGN) button**

This button is used in conjunction with other controls to assign inserts/plug-ins to channels. See “Assigning Inserts/Plug-ins” on page 244 for more information.

**[6] (COMPARE) button**

This button is used to compare plug-in edits before and after. See “Editing Plug-ins” on page 245 for more information.

**[7] (BYPASS) button**

This button is used to bypass plug-ins. See “Editing Plug-ins” on page 245 and “Bypassing Individual Plug-ins” on page 246 for more information.

**[8] (INSERT/PARAM) button**

This button is used in conjunction with other controls when editing plug-ins. See “Editing Plug-ins” on page 245 for more information.

**Parameter Up (< SCROLL) & Parameter Down (SCROLL >) buttons**

These buttons are used to scroll parameters when assigning inserts and editing plug-ins. See “Assigning Inserts/Plug-ins” on page 244 and “Editing Plug-ins” on page 245 for more information.

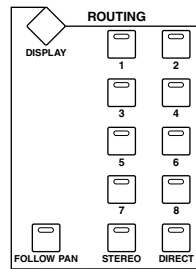
**SELECTED CHANNEL Section****■ ROUTING****[1] button**

Selects the previous track to be controlled by the Joystick.

**[2] button**

Selects the next track to be controlled by the Joystick.

**[3] button**

Functions the same as the [OPTION] key on a computer keyboard.

**[4] button**

Switches between L and R of the selected track. The [4] button indicator lights up when the R channel is selected.

**[5] button**

Selects Main, or Send (in this order) for the selected track.

**[6] button**

Switches the mode of the knob controls for the panner. The [6] button indicator lights up or turns off.

**[7] button**

Selects Send, or Main (in this order) for the selected track.

**[8] button**

Mutes or unmutes the selected track. The [8] button indicator lights up while the track is muted.

**[DIRECT] button**

Functions the same as the [SHIFT] key on the computer keyboard.

■ DYNAMICS

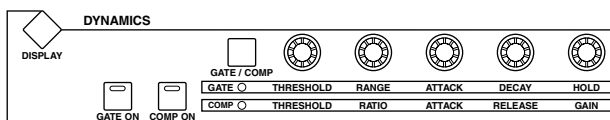

**[THRESHOLD] control**

If the ROUTING [6] button indicator is off, the [THRESHOLD] control adjusts the front position. If the ROUTING [6] button indicator is lit, the control adjusts the front divergence.

**[RANGE/RATIO] control**

If the ROUTING [6] button indicator is off, the [RANGE/RATIO] control adjusts the rear position. If the ROUTING [6] button indicator is lit, the control adjusts the rear divergence.

**[ATTACK] control**

If the ROUTING [6] button indicator is off, the [ATTACK] control adjusts the F/R (front/rear) position. If the ROUTING [6] button indicator is lit, the control adjusts the F/R (front/rear) divergence.

**[DECAY/RELEASE] control**

If the ROUTING [6] button indicator is off, the [DECAY/RELEASE] control adjusts the LFE level. If the ROUTING [6] button indicator is lit, this control adjusts the center percentage.

**[HOLD/GAIN] control**

Adjusts the channel volume.

■ PAN/SURROUND

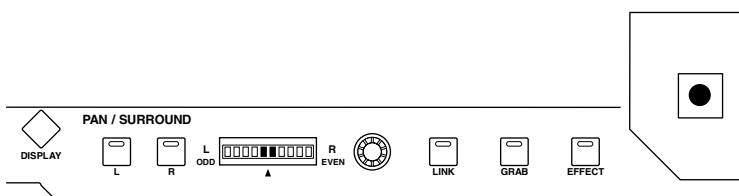

**[GRAB] button**

Press this button, turning on the button indicator, then operate the Joystick to quickly set the pan position.

**Joystick**

Operating the Joystick while the [GRAB] button indicator is turned on enables you to quickly set the pan position.



## TRACK ARMING Section

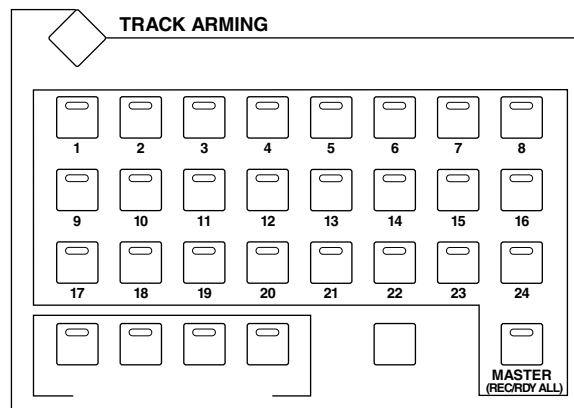

### [1–24] (REC/RDY) buttons

These buttons are used to arm Pro Tools channels for recording. The button indicators of channels that are armed flash. The button indicators of armed channels light continuously when recording starts.

### [MASTER] (REC/RDY ALL) button

This button is used to arm all Pro Tools channels for recording. The button indicators of all channels flash when this button is pressed. All channels can be disarmed by pressing it again, in which case all button indicators go out. The number of channels that can be armed depends on the number of recordable tracks in the current Pro Tools session.

The following shortcuts apply.

To do this...	Do this!
Arm all channels (same as [MASTER] (REC/RDY ALL) button)	USER DEFINED KEYS [5] + TRACK ARMING [1–24]
Arm all selected channels	USER DEFINED KEYS [5] + USER DEFINED KEYS [4] + TRACK ARMING [1–24]

## AUTOMIX Section

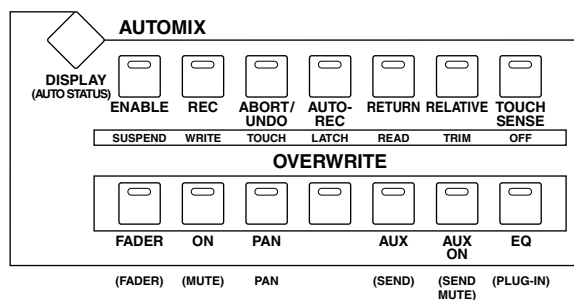

### [DISPLAY] (AUTO STATUS) button

When this button is pressed, the Automation modes of all channels are displayed on the channel strip displays. See “Viewing the Automation Mode” on page 250 for more information.

### [ENABLE] (SUSPEND) button

This button is used to suspend all automation recording and playback operations. Its button indicator flashes while automation is suspended. Level and other channel strip settings are left as they are while automation is suspended.

**[REC] (WRITE), [ABORT/UNDO] (TOUCH), [AUTOREC] (LATCH), [RETURN] (READ), [RELATIVE] (TRIM) & [TOUCH SENSE] (OFF) buttons**  
 These buttons are used to select the channel Automation modes. See “Setting the Automation Mode” on page 250 for more information.

**OVERWRITE [FADER] (FADER), [ON] (MUTE), [PAN] (PAN), [AUX] (SEND), [AUX ON] (SEND MUTE) & [EQ] (PLUG-IN) buttons**  
 These buttons are used to select parameters for automation recording and playback. See “Arming Parameters for Automation” on page 251 for more information.

## USER DEFINED KEYS Section

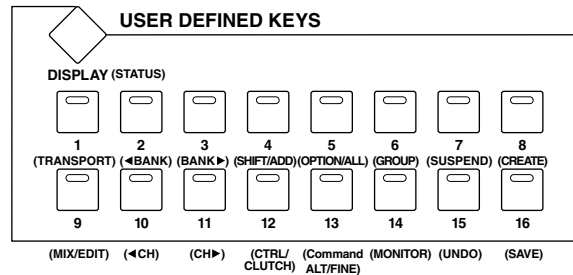

### [DISPLAY] (STATUS) button

This button is used to open and close the Session Setup window.

### [1] (TRANSPORT) button

This button is used to open and close the Transport window. Its indicator lights up while the Transport window is open.

### [2] (< BANK) & [3] (BANK >) buttons

These buttons are used to swap channel banks 24 channels at a time.

### [4] (SHIFT/ADD) & [5] (OPTION/ALL) buttons

These buttons are used in conjunction with other buttons to modify function operation. They correspond to the Shift and Option modifier keys found on Macintosh keyboards.

### [6] (GROUP) button

This button is used to display group information for all channels. While it's pressed, the channel strip displays show the ID of any group in which each channel is assigned.

### [7] (SUSPEND) button

This button is used to temporarily suspend all mix groups (not edit groups). Its indicator flashes while mix groups are suspended.

### [8] (CREATE) button

This button is used to open the New Group window (Command-G in Pro Tools).

### [9] (MIX/EDIT)

This button is used to toggle between the Mix and Edit windows.

### [10] (< CH) & [11] (CH >) buttons

These buttons are used to scroll channels one at a time.

**[12] (CTRL/CLUTCH) & [13] (Command-ALT/FINE) buttons**

These buttons are used in conjunction with other buttons to modify function operation. They correspond to the Control and Command modifier keys found on Macintosh keyboards.

**[14] (MONITOR) button**

This button is used to display the monitor mode currently selected in the Pro Tools Operations menu. When the monitor mode is set to “Auto Input Monitor,” “Auto” is displayed. When it’s set to “Input Only Monitor,” “Inpt” is displayed. Aux Input channels always display “AUX.” Master fader channels always display “Mstr.” And MIDI Tracks always display “MIDI.”

**[15] (UNDO) button**

This button is used to undo and redo the last operation. Its indicator lights up when the last operation can be undone, and it flashes when the last operation can be redone.

**[16] (SAVE)**

This button is used to save the current session (same as Save Session command in the File menu). Its indicator lights up when there are unsaved changes, and goes out when there are no unsaved changes. When pressed, the indicator flashes and you can press it again to go ahead and save the current session, or press [ESC] to cancel.

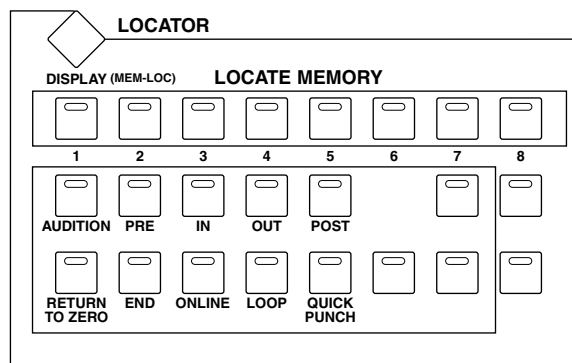
**LOCATOR Section****[DISPLAY] (MEM-LOC) button**

This button is used to open and close the Memory Locations window.

**LOCATE MEMORY [1–8] buttons**

These buttons perform the same transport-related functions as the 1–8 number keys on a Macintosh keyboard. If you set the Numeric keypad Mode in Pro Tools to “Classic” (Setups menu, Preferences), these buttons can be used to directly locate markers 1–8.

**[AUDITION] button**

This button is used in conjunction with the [PRE], [IN], [OUT], and [POST] buttons for auditioning. Its indicator lights up while auditioning is on and operation is as follows:

- Press the [PRE] button to audition the section between the pre-roll point and the in point of the selected region.
- Press the [IN] button to audition from the in point of the selected region, continuing for the specified pre-roll time.
- Press the [OUT] button to audition the section before the out point of the selected region. The length of the section is determined by the post-roll time.

- Press the [POST] button to audition from the out point of the selected region, continuing for the specified post-roll time.

Auditioning stops when you press the [STOP] button in the transport section, or when playback reaches the end of a section.

**[PRE] & [POST] buttons**

These buttons are used to turn on and off pre-roll and post-roll. While the [AUDITION] button indicator is lit, they are used for auditioning.

**[IN] & [OUT] buttons**

These buttons are used to set in and out points during playback. While the [AUDITION] button indicator is lit, they are used for auditioning.

**[RETURN TO ZERO] button**

Pressing this button moves the playback cursor to the beginning of the session.

**[END] button**

Pressing this button moves the playback cursor to the end of the session.

**[ONLINE] button**

This button is used to take Pro Tools online and offline (same as the Online command in the Operations menu). Its indicator lights up when Pro Tools is online.

**[LOOP] button**

This button is used to turn loop playback on and off (same as the Loop Playback command in the Operations menu). Its indicator lights up when loop playback is on.

**[QUICK PUNCH] button**

This button is used to turn quick punch on and off (same as the Quick Punch command in the Operations menu). Its indicator lights up when quick punch is on.

## Data Entry & Transport Section

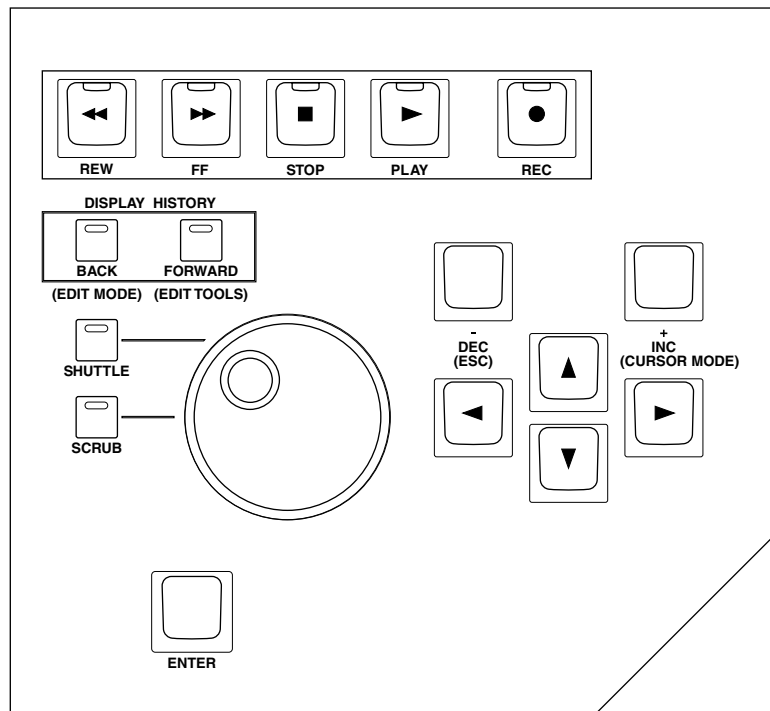

### [REW] button

This button rewinds from the current cursor position (it's non-latching).

### [FF] button

This button fast forwards from the current cursor position (it's non-latching).

### [STOP] button

This button stops playback and recording.

### [PLAY] button

This button starts playback from the current cursor position.

### [REC] button

This button arms Pro Tools for recording ([REC] button indicator flashing), recording is started by pressing the [PLAY] button ([REC] button indicator lit continuously).

### [BACK] (EDIT MODE) button

This button is used to select the following edit modes: Shuffle, Slip, Spot, and Grid.

### [FORWARD] (EDIT TOOLS) button

This button is used to select the following edit tools: Zoomer, Trimmer, Selector, Grabber, SmartTool, Scrubber, and Pencil.

### Parameter Wheel

The Parameter wheel is used for shuttling and scrubbing (see page 249). It's also used for making fine adjustments to the selected region (see page 248).

**[SHUTTLE] & [SCRUB] buttons**

These buttons are used to select the Shuttle and Scrub modes. See “Scrub & Shuttle” on page 249 for more information. These buttons are mutually exclusive with the [QUICK PUNCH] and [LOOP] buttons. Also, the cursor in the window on the computer monitor disappears.

**[ENTER] button**

This button works the same as the Enter key on your computer keyboard. Pressing it opens the New Memory Location dialog box. While a dialog box is open, pressing it performs the same action as clicking the OK button.

**[–/DEC] (ESC) button**

For the most part, this button works the same as the Esc key on your computer keyboard. While a dialog box is open, pressing it performs the same action as clicking the Cancel button.

**[+INC] (CURSOR MODE) button**

This button is used to select the following cursor modes: Navigation (see page 247), Zoom (see page 248), and Select (see page 248).

**Cursor buttons**

These buttons can be used to scroll the Mix and Edit windows (see page 238), navigate the Edit window (see page 247), zoom waveforms (see page 248), and to make fine adjustments to the selected region (see page 248). Their exact operation depends on the currently selected cursor mode.

## Scrolling Windows

The following shortcuts can be used to scroll the Mix and Edit windows.

Scroll window to the left	USER DEFINED KEYS [13] + Left cursor button
Scroll window to the right	USER DEFINED KEYS [13] + Right cursor button
Scroll window up	USER DEFINED KEYS [13] + Up cursor button
Scroll window down	USER DEFINED KEYS [13] + Down cursor button
Scroll window to the beginning	USER DEFINED KEYS [5] + USER DEFINED KEYS [13] + Left cursor button
Scroll window to the end	USER DEFINED KEYS [5] + USER DEFINED KEYS [13] + Right cursor button
Scroll window to the top	USER DEFINED KEYS [5] + USER DEFINED KEYS [13] + Up cursor button
Scroll window to the bottom	USER DEFINED KEYS [5] + USER DEFINED KEYS [13] + Down cursor button

## Selecting Channels

Channels can be selected as follows.

(Make sure the ENCODER MODE [ASSIGN 4] (INSERT) button indicator is not lit before proceeding.)

**1 Use the [SEL] buttons to select channels.**

The [SEL] button indicators of selected channels light up. The border of the corresponding channel strip displays also light up.

**2 To select multiple channels in each eight-channel block (e.g., 1–8, 9–16, or 17–24), while holding down one [SEL] button, use the [SEL] buttons of the other channels in the same block to add and remove channels.**

The following shortcuts apply.

To do this...	Do this!
Select multiple channels	USER DEFINED KEYS [4] + [SEL]
Select all channels	USER DEFINED KEYS [5] + [SEL]
Inverse the channel selection	USER DEFINED KEYS [13] + [SEL]

## Assigning Inputs to Channels

Channels can be assigned to input sources as follows. Before starting the steps below, stop the Pro Tools transport section.

You can view the current input source assignment for each channel on the channel strip displays by pressing and holding the ENCODER MODE [ASSIGN 1] (INPUT) button.

**1 Press the ENCODER MODE [ASSIGN 3] (SEND ASSIGN) button.**

Its button indicator flashes, and the SELECT ASSIGN section of the display shows “ASGN.”

**2 Press the ENCODER MODE [ASSIGN 1] (INPUT) button.**

Its button indicator lights up, and the channel strip displays show the current input source for each channel.

**3 Use the Encoders to select input sources.**

The names of the input sources appear on the channel strip displays in abbreviated form. When you select a source other than the current, the ring of the corresponding channel strip display flashes.

**4 To confirm your selection, press the Encoder’s push-switch.**

The channel strip display ring stops flashing.

The following shortcuts apply.

To do this...	Do this!
Set all channels to the same input source	ENCODER MODE [ASSIGN 3], ENCODER MODE [ASSIGN 1], Encoder, USER DEFINED KEYS [5] + Encoder push-switch
Set all selected channels to the same input source	ENCODER MODE [ASSIGN 3], ENCODER MODE [ASSIGN 1], Encoder, USER DEFINED KEYS [5] + USER DEFINED KEYS [4] + Encoder push-switch

You can cancel this function by pressing the [–/DEC] (ESC) button.

## Assigning Outputs to Channels

Channels can be assigned to output destinations as follows. Before starting the steps below, stop the Pro Tools transport section.

You can view the current output destination assignment for each channel on the channel strip displays by pressing and holding the ENCODER MODE [ASSIGN 2] (OUTPUT) button.

**1 Press the ENCODER MODE [ASSIGN 3] (SEND ASSIGN) button.**

Its indicator flashes, and the SELECT ASSIGN section of the display shows “ASGN.”

**2 Press the ENCODER MODE [ASSIGN 2] (OUTPUT) button.**

Its indicator lights up, and the channel strip displays show the current output destination for each channel.

**3 Use the Encoders to select output destinations.**

The names of the output destinations appear on the channel strip displays in abbreviated form. When you select a destination other than the current, the ring of the corresponding channel strip display flashes.

**4 To confirm your selection, press the Encoder’s push-switch.**

The channel strip display ring stops flashing.

The following shortcuts apply.

To do this...	Do this!
Set all channels to the same output destination	ENCODER MODE [ASSIGN 3], ENCODER MODE [ASSIGN 2], Encoder, USER DEFINED KEYS [5] + Encoder push-switch
Set all selected channels to the same output destination	ENCODER MODE [ASSIGN 3], ENCODER MODE [ASSIGN 2], Encoder, USER DEFINED KEYS [5] + USER DEFINED KEYS [4] + Encoder push-switch

You can cancel this function by pressing the [–/DEC] (ESC) button.

## Setting Channel Levels

Channel levels can be set as follows.

(Make sure the FADER MODE [FADER] and [AUX/MTRX] button indicators are not flashing before proceeding.)

**1 Use the faders to set channels levels.**

Faders in a mix group are controlled together. You can temporarily disable a mix group in order to make adjustments to individual faders by pressing and holding the USER DEFINED KEYS [12] (CTRL/CLUTCH) button. Alternatively, you can make adjustments to individual faders while touching the knob of at least one fader in that mix group.

You can view channel levels in dB on the channel strip displays by holding down the USER DEFINED KEYS [13] (ALT/FINE) button while adjusting faders.



## Muting Channels

Channels can be muted as follows.

- 1 Use the [ON] buttons to mute channels.**

The [ON] button indicators of muted channels go out.

- 2 Press the [ON] buttons again to unmute channels.**

The [ON] button indicators of unmuted channels are lit.

Grouped channels are muted together. You can temporarily disable a group in order to mute individual channels by pressing and holding the USER DEFINED KEYS [12] (CTRL/CLUTCH) button.

The following shortcuts apply.

To do this...	Do this!
Mute all channels	USER DEFINED KEYS [5] + [ON]
Mute all selected channels	USER DEFINED KEYS [5] + USER DEFINED KEYS [4] + [ON]

## Panning Channels

Channels can be panned as follows.

- 1 Press the ENCODER MODE [PAN] (PAN) button.**

Its indicator lights up.

- 2 Use the Encoders to pan the channels.**

Pan positions are displayed by the channel strip displays. See “Pan Display” on page 227 for more information.

You can view pan settings numerically on the channel strip displays by holding down the USER DEFINED KEYS [13] (ALT/FINE) button while adjusting the Encoders.

For stereo aux input channels (i.e., channels with two panpots), use the ENCODER MODE [PAN] (PAN) button to toggle between the left and right panpots, and pan with the Encoder. When the left panpot is active, the ENCODER MODE [PAN] (PAN) button indicator is lit continuously and the SELECT ASSIGN section of the display shows “Pan.” When the right panpot is active, the ENCODER MODE [PAN] (PAN) button indicator flashes and the SELECT ASSIGN section of the display shows “PanR.”

## Soloing Channels

Channels can be soloed as follows.

- 1 Use the [SOLO] buttons to solo channels.**

The [SOLO] button indicators of soloed channels light up and the [ON] button indicators of unsoloed channels flash.

- 2 Press the [SOLO] buttons again to unsolo channels.**

Grouped channels are soloed together. You can temporarily disable a mix group in order to solo individual channels by pressing and holding the USER DEFINED KEYS [12] (CTRL/CLUTCH) button.

## Assigning Send Destinations

Sends can be assigned to output destinations as follows. Before starting the steps below, stop the Pro Tools transport section.

You can view the current output destination assignment for each send on the channel strip displays by pressing and holding the AUX SELECT [AUX 1]–[AUX 5] (SEND A–E) buttons.

**1 Press the ENCODER MODE [ASSIGN 3] (SEND ASSIGN) button.**

Its indicator flashes, and the SELECT ASSIGN section of the display shows “ASGN.”

**2 Use the AUX SELECT [AUX 1]–[AUX 5] (SEND A–E) buttons to select the sends.**

The button indicator of the selected send lights up, and the channel strip displays show the current send destinations of all channels. If the currently selected send is not assigned to a channel, “—” is displayed.

**3 Use the Encoders to select send destinations.**

The names of the send destinations appear on the channel strip displays in abbreviated form. When you select a different destination, the ring of the corresponding channel strip display flashes. When a stereo send destination is selected, its name flashes and continues to flash even after its been confirmed.

**4 To confirm your selection, press the Encoder’s push-switch.**

The channel strip display ring stops flashing.

The following shortcuts apply.

To do this...	Do this!
Set all channels to the same send destination	ENCODER MODE [ASSIGN 3], AUX SELECT [AUX 1]–[AUX 5], Encoder, USER DEFINED KEYS [5] + Encoder push-switch
Set all selected channels to the same send destination	ENCODER MODE [ASSIGN 3], AUX SELECT [AUX 1]–[AUX 5], Encoder, USER DEFINED KEYS [5] + USER DEFINED KEYS [4] + Encoder push-switch

You can cancel this function by pressing the [–/DEC] (ESC) button.

## Configuring Sends as Pre or Post

Sends can be configured as either pre or post as follows.

(Make sure the MATRIX SELECT [MATRIX 2] (SEND MUTE) button indicator is not lit before proceeding.)

**1 Use the AUX SELECT [AUX 1]–[AUX 5] (SEND A–E) buttons to select the sends.**

The ENCODER MODE [AUX/MTRX] (SEND LEVEL) button indicator lights up, as does the button indicator of the selected send.

**2 Use the Encoder push-switches to toggle between pre and post.**

## Setting Send Levels

Send levels can be set as follows.

- 1 Use the AUX SELECT [AUX 1]–[AUX 5] (SEND A–E) buttons to select the sends.**

The ENCODER MODE [AUX/MTRX] (SEND LEVEL) button indicator lights up, as does the button indicator of the selected send.

The levels for the selected send are displayed by the channel strip displays. See “Send Level” on page 227 for more information.

- 2 Use the Encoders to set the send levels.**

You can view send levels in dB on the channel strip displays by holding down the USER DEFINED KEYS [13] (ALT/FINE) button while adjusting the Encoders.

Send levels can also be set by using the faders in Flip mode. See “Flip Mode” on page 243 for more information.

## Muting Sends

Sends can be muted as follows.

- 1 Press the MATRIX SELECT [MATRIX 2] (SEND MUTE) button.**
- 2 Use the AUX SELECT [AUX 1]–[AUX 5] (SEND A–E) buttons to select the sends.**

The ENCODER MODE [AUX/MTRX] (SEND LEVEL) button indicator lights up, as does the button indicator of the selected send.

- 3 Use the Encoder push-switches to mute the sends.**

When a send is muted, the ring of the corresponding channel strip display flashes.

Sends can also be muted by using the [ON] buttons in Flip mode. See “Flip Mode” on page 243 for more information.

## Panning Sends

Only sends assigned to stereo destinations can be panned. Sends can be panned by using the Encoders in Flip mode. See “Flip Mode” on page 243 for more information.

## Flip Mode

In Flip mode, the faders, Encoders, and [ON] buttons can be used to control sends, as shown in the following table.

Control	Normal mode	Flip mode
Fader	Channel level	Send level
Encoder	Channel pan/send level	Send pan
[ON] button	Channel mute	Send mute

- 1 Press the FADER MODE [FADER] or [AUX/MTRX] button.**

The FADER MODE [FADER] and [AUX/MTRX] button indicators flash alternately, and both the ENCODER MODE [PAN] (PAN) and [AUX/MTRX] (SEND LEVEL) button indicators light up. The SELECT ASSIGN section of the display shows “FLIP”

- 2 Use the AUX SELECT [AUX 1]–[AUX 5] (SEND A–E) buttons to select the sends.**

The button indicator of the selected send lights up.

**3 Use the faders, Encoders, and [ON] buttons to control the currently selected send.**

For stereo aux input channels (i.e., channels with two send panpots), use the ENCODER MODE [PAN] (PAN) button to toggle between the left and right panpots, and pan with the Encoder. When the left panpot is active, the ENCODER MODE [PAN] (PAN) button indicator is lit continuously. When the right panpot is active, the ENCODER MODE [PAN] (PAN) button indicator flashes.

## Assigning Inserts/Plug-ins

Inserts can be assigned to channels as follows. The Pro Tools transport must be stopped in order to make these assignments.

**1 Press the ENCODER MODE [ASSIGN 4] (INSERT) button.**

Its indicator lights up and the [SEL] buttons are set to Insert Select mode.

**2 Use the [SEL] buttons to select channels for insert assignment.**

The name of the selected channel appears in the INSERT/PARAM section of the display. The border of the corresponding channel name in the Pro Tools Mix window is highlighted red.

**3 Press the EFFECTS/PLUG-INS [5] (ASSIGN) button.**

Its indicator flashes, as does the ASSIGN indicator on the display.

**4 Use Parameter controls 1–4 to select inserts/plugin-ins.**

The names of the inserts/plugin-ins appear on the display in abbreviated form. When you select an insert/plugin-in other than the current, the corresponding SEL button flashes on the display.

**5 To confirm your selection, press the relevant Parameter control's push-switch.**

The SEL button stops flashing.

While the EFFECTS/PLUG-INS [5] (ASSIGN) button indicator is still flashing, you can assign more inserts/plugin-ins to the same channel. To set insert #5, press the Parameter Down (SCROLL >) button. Press the Parameter Up (< SCROLL) button to view inserts 1–4 again.

To assign inserts/plugin-ins to other channels, use the [SEL] buttons to select them. You'll need to press the EFFECTS/PLUG-INS [5] (ASSIGN) button each time you select another channel.

To assign the same insert/plugin-in to all channels, while holding down the USER DEFINED KEYS [5] (OPTION/ALL) button, press the Parameter control push-switch. (The number of assignments possible depends on the available CPU power.)

To assign the same insert/plugin-in to a selection of channels, press the ENCODER MODE [ASSIGN 4] (INSERT) button (indicator off) so that the [SEL] buttons can be used to select channels. Select the channels as explained on page 239, then press the EFFECTS/PLUG-INS [5] (ASSIGN) button. While its indicator is flashing, use Parameter controls 1–4 to select an insert/plugin-in, and while holding down the USER DEFINED KEYS [5] (OPTION/ALL) button and USER DEFINED KEYS [4] (SHIFT/ADD) button, press the Parameter control's push-switch. (The number of assignments possible depends on the available CPU power.) You can cancel this function by pressing the [–/DEC] (ESC) button.

## Editing Plug-ins

Plug-ins can be edited as follows.

(Make sure the MATRIX SELECT [MATRIX 4] (INSERT BYPASS) button indicator is not lit before proceeding.)

**1 Press the ENCODER MODE [ASSIGN 4] (INSERT) button.**

Its indicator lights up and the [SEL] buttons are set to Insert Select mode.

**2 Use the [SEL] buttons to select the channel whose plug-in you want to edit.**

That channel's [SEL] button indicator lights up, and the border of the corresponding channel name in the Pro Tools Mix window is highlighted red. The names of the Plug-ins inserted in the channel are displayed in the INSERT ASSIGN/EDIT section of the display.

**3 Use the Parameter control 1–4 push-switches to select the plug-in that you want to edit.**

Plug-in Edit mode is set and the plug-in's parameters are displayed in the INSERT ASSIGN/EDIT section of the display. The EFFECTS/PLUG-INS [8] (INSERT/PARAM) button indicator lights up and the PARAM indicator on the display appears highlighted.

**4 Use Parameter controls 1–4 and their push-switches to edit the displayed parameters.**

Parameters displayed on the top row can be edited by using the push-switches. Parameters displayed on the bottom row can be edited by using the Parameter controls.

**5 Use the Parameter Down (SCROLL >) button and Parameter Up (< SCROLL) button to select the parameter pages.**

When a parameter page is first selected, the number of the current parameter page and the total number of parameter pages is displayed momentarily. For example, "1/2" indicates that the first page of two is currently selected. While "3/4" indicates that the third page of four is currently selected. The title of the plug-in is also displayed.

While editing a plug-in you can bypass it by pressing the EFFECTS/PLUG-INS [7] (BYPASS) button. In which case, the BYPASS indicator on the display appears highlighted.

As soon as you begin editing a plug-in, the COMPARE indicator on the display appears highlighted. You can compare your edits with the original settings by pressing the EFFECTS/PLUG-INS [6] (COMPARE) button. The COMPARE indicator on the display appears highlighted while the original settings are active, and unhighlighted while your edits are active.

**6 To edit another plug-in, press the EFFECTS/PLUG-INS [8] (INSERT/PARAM) button (its indicator goes out), use the [SEL] buttons to select the channel (same as step #2), and use the Parameter control 1–4 push-switches to select the plug-in (same as step #3).**

## Bypassing Individual Plug-ins

Individual plug-ins can be bypassed as follows.

(Make sure the EFFECTS/PLUG-INS [8] (INSERT/PARAM) button indicator is not lit before proceeding.)

- 1 **Press the ENCODER MODE [ASSIGN 4] (INSERT) button.**  
Its indicator lights up and the [SEL] buttons are set to Insert Select mode.
- 2 **Use the [SEL] buttons to select plug-ins.**
- 3 **While holding down the EFFECTS/PLUG-INS [7] (BYPASS) button, use Parameter control 1–4 push switches to bypass the plug-ins.**

To bypass plug-in #5, press the Parameter Down (SCROLL >) button, and then perform step 3. Press the Parameter Up (< SCROLL) button to view plug-ins 1–4 again.

The titles of bypassed plug-ins are displayed in uppercase characters. For example, the title of the plug in “D-Verb” appears as “d-verb” when it’s not bypassed, and appears as “D-VERB” when it is bypassed.

## Bypassing all Plug-ins

All plug-ins on a channel can be bypassed as follows.

- 1 **Press the MATRIX SELECT [MATRIX 4] (INSERT BYPASS) button.**

Its indicator lights up.

The INS indicators on the channel strip displays work as follows.

INS indicator = off: None of the channel’s plug-ins are bypassed.

INS indicator = lit: All of the channel’s plug-ins are bypassed.

INS indicator = flashing: Some of the channel’s plug-ins are bypassed.

- 2 **Press the ENCODER MODE [ASSIGN 4] (INSERT) button.**  
Its indicator flashes.
- 3 **Use the [SEL] buttons to bypass all plug-ins on each channel.**

The following shortcuts apply.

To do this...	Do this!
Bypass all plug-ins on all channels	MATRIX SELECT [MATRIX 4], ENCODER MODE [ASSIGN 4], USER DEFINED KEYS [5] + [SEL]
Bypass all plug-ins on all selected channels	MATRIX SELECT [MATRIX 4], ENCODER MODE [ASSIGN 4], USER DEFINED KEYS [5] + USER DEFINED KEYS [4] + [SEL]

## Resetting Faders, Sends, Panpots & Plug-ins

Faders, panpots, sends, and plug-ins can be reset to their default values as follows. For faders and send controls, this is “0.” For panpots, it’s center.

Make sure that the ENCODER MODE [ASSIGN 4] (INSERT) button indicator is off before proceeding with these shortcuts.

To do this...	Do this!
Reset a channel fader	[MATRIX 1] + [SEL]
Reset all channel faders	USER DEFINED KEYS [5] + [MATRIX 1] + [SEL]
Reset all selected channel faders	USER DEFINED KEYS [5] + USER DEFINED KEYS [4] + [MATRIX 1] + [SEL]
Reset a channel panpot	[PAN], [MATRIX 1] + [ENCODER push]
Reset all channel panpots	[PAN], USER DEFINED KEYS [5] + [MATRIX 1] + [ENCODER push]
Reset all selected channel panpots	[PAN], USER DEFINED KEYS [5] + USER DEFINED KEYS [4] + [MATRIX 1] + [ENCODER push]
Reset a channel send level	AUX SELECT [AUX 1]–[AUX 5], [MATRIX 1] + [ENCODER push]
Reset all channel send levels	AUX SELECT [AUX 1]–[AUX 5], USER DEFINED KEYS [5] + [MATRIX 1] + [ENCODER push]
Reset all selected channel send levels	AUX SELECT [AUX 1]–[AUX 5], USER DEFINED KEYS [5] + USER DEFINED KEYS [4] + [MATRIX 1] + [ENCODER push]
Reset the currently selected plug-in	[MATRIX 1] + EFFECTS PLUG-INS [6]

While the [MATRIX 1] (DEFAULT) button is being pressed, its indicator flashes and “DFLT” appears in the SELECT ASSIGN section of the display.

Grouped channels are reset together. You can temporarily disable a group by pressing and holding the USER DEFINED KEYS [12] (CTRL/CLUTCH) button before pressing the [MATRIX 1] (DEFAULT) button.

## Navigating the Edit Window

The cursor buttons can be used to navigate the Edit window as follows.

- 1 Use the [INC] (CURSOR MODE) button to select Navigation cursor mode.**  
The CURSOR MODE section of the display shows “NAVIGATION.”
- 2 To move the edit cursor to the previous region boundary, or to the previous marker, press the Left cursor button.**
- 3 To move the edit cursor to the next region boundary, or to the next marker, press the Right cursor button.**
- 4 To select the track above, press the Up cursor button.**
- 5 To select the track below, press the Down cursor button.**

The following shortcuts apply.

To do this...	Do this!
Extend the selection	USER DEFINED KEYS [4] + Left or Right cursor button
Select the previous region	USER DEFINED KEYS [12] + Left cursor button
Select the next region	USER DEFINED KEYS [12] + Right cursor button
Display the in point of the selected region in the center of the Edit window	USER DEFINED KEYS [5] + Left cursor button (or LOCATE MEMORY [IN] button)
Display the out point of the selected region in the center of the Edit window	USER DEFINED KEYS [5] + Right cursor button (or LOCATE MEMORY [OUT] button)

## Zooming

The cursor buttons can be used to zoom the Edit window as follows.

**1 Use the [+INC] (CURSOR MODE) button to select Zoom cursor mode.**

The CURSOR MODE section of the display shows “ZOOM.”

In Zoom cursor mode, the cursor buttons work as follows:

- Left cursor button: Zoom out horizontally.
- Right cursor button: Zoom in horizontally.
- Up cursor button: Zoom in vertically.
- Down cursor button: Zoom out vertically.

## Making Fine Adjustments to the Selected Region

The cursor buttons can be used in conjunction with the Parameter wheel to make fine adjustments to the selected region.

**1 Use the [+INC] (CURSOR MODE) button to select Select cursor mode.**

The CURSOR MODE section of the display shows “SELECT.”

**2 While holding down the left cursor button, turn the Parameter wheel to make fine adjustments to the in point of the selected region.**

**3 While holding down the right cursor button, turn the Parameter wheel to make fine adjustments to the out point of the selected region.**

The following shortcuts apply.

To do this...	Do this!
Move the edit cursor to the in point of the selected region	Double-click the Left cursor button
Move the edit cursor to the out point of the selected region	Double-click the Right cursor button

The following shortcuts can be used in either Navigation or Select cursor mode.

To do this...	Do this!
Select the track/region below	Down cursor button
Select the track/region above	Up cursor button
Extend the selection to include the same region on the track below	USER DEFINED KEYS [4] + Down cursor button
Extend the selection to include the same region on the track above	USER DEFINED KEYS [4] + Up cursor button
Shorten the selection by unselecting the region on the lowest track	USER DEFINED KEYS [5] + Down cursor button
Shorten the selection by unselecting the region on the highest track	USER DEFINED KEYS [5] + Up cursor button
Move the selection (not the audio) backwards or forwards	Left cursor button+Right cursor button+Parameter wheel



## Scrub & Shuttle

The Parameter wheel can be used to scrub and shuttle as follows.

- 1 **Make sure that Pro Tools is stopped.**
- 2 **Press the [SCRUB] button if you want to scrub, press the [SHUTTLE] button if you want to shuttle.**

The corresponding button indicator lights up. The [REW] and [FF] button indicators also light up, and the cursor mode is set to Navigation (the CURSOR MODE section of the display shows “NAVIGATION”).

- 3 **Turn the Parameter wheel clockwise to scrub/shuttle forwards. Turn it counterclockwise to scrub/shuttle backwards.**

Scrub/shuttle starts at the in point of the selected region. If no region is selected, the edit cursor position is used. If you hold down the USER DEFINED KEYS [5] (OPTION/ALL) button when pressing the [SCRUB] or [SHUTTLE] button, scrub/shuttle will start at the out point of the selected region.

If the Edit Insertion Follows Scrub/Shuttle preference is turned on in Pro Tools (Setups menu, Preferences command, Operation page), the currently selected region will be cancelled when the [SCRUB] or [SHUTTLE] button is pressed. To maintain the currently selected region, hold down the USER DEFINED KEYS [4] (SHIFT/ADD) button when pressing the [SCRUB] or [SHUTTLE] button.

You can toggle between scrub and shuttle by pressing the [SCRUB] and [SHUTTLE] buttons, in which case scrub or shuttle continues from the current position.

- 4 **To expand or shrink the selected region, while holding down the USER DEFINED KEYS [4] (SHIFT/ADD) button, rotate the Parameter wheel.**

Press the left cursor button when you want to move the in point. Press the right cursor button, to move the out point.

To start Scrub/Shuttle from the top of the selected region, while holding down the USER DEFINED KEYS [5] (OPTION/ALL) button, press the left cursor button. Similarly, to start Scrub/Shuttle from the end of the selected region, while holding down the USER DEFINED KEYS [5] (OPTION/ALL) button, press the right cursor button.

- 5 **To stop scrub/shuttle, press the [SCRUB] or [SHUTTLE] button again, or press the [STOP] button.**

If you press the [REW], [FF], or [PLAY] button, scrub/shuttle operation is stopped before rewind, fast forward, or playback commences.

While scrub/shuttle is active, only the following Pro Tools/DM2000 controls can be used: [SCRUB] and [SHUTTLE] buttons, Parameter wheel, transport buttons, faders, [ON] buttons, and [SOLO] buttons. The current position can be stored as a marker by pressing the [ENTER] button.

The scrub resolution depends on the current zoom setting, the more zoomed in you are, the higher the resolution. If you hold down the USER DEFINED KEYS [13] (ALT/FINE) button while scrubbing, you can scrub at the highest resolution regardless of the current zoom setting.

## Automation

### Viewing the Automation Mode

The Automation mode setting of each channel can be viewed as follows.

#### 1 Press and hold a channel's [AUTO] button.

The channel's Automation mode is displayed on the corresponding channel strip display while the [AUTO] button is pressed.

Pro Tools	Channel Strip Displays	[AUTO] Button Indicators
Auto write	Wrt	Flashing red (Record Ready) Red (Recording)
Auto touch	Tch	
Auto latch	Ltch	
Auto read	Read	Green
Auto off	Off	Off

The Automation mode settings of all channels can be viewed as follows.

#### 2 Press and hold the AUTOMIX [DISPLAY] (AUTO STATUS) button.

The Automation modes of all channels are displayed on the channel strip displays while the AUTOMIX [DISPLAY] (AUTO STATUS) button is pressed.

### Setting the Automation Mode

The Automation mode can be set as follows.

#### 1 While holding down a channel's [AUTO] button, press the AUTOMIX [WRITE], [TOUCH], [LATCH], [TRIM], [READ], or [OFF] button.

The channel's Automation mode is displayed on the corresponding channel strip display while the [AUTO] button is pressed.

Grouped channels are set together. You can temporarily disable a group in order to set individual channels by pressing and holding the USER DEFINED KEYS [12] (CTRL/CLUTCH) button.

The following shortcuts apply.

To do this...	Do this!
Set the Automation mode of all channels	USER DEFINED KEYS [5] + AUTOMIX [WRITE], [TOUCH], [LATCH], [TRIM], [READ], or [OFF]
Set the Automation mode of all selected channels	USER DEFINED KEYS [5] + USER DEFINED KEYS [4] + AUTOMIX [WRITE], [TOUCH], [LATCH], [TRIM], [READ], or [OFF]

## Trim Mode

Trim mode can be set as follows.

- 1 **While holding down a channel's [AUTO] button, press the AUTOMIX [RELATIVE] (TRIM) button.**

The channel's Automation mode is displayed on the corresponding channel strip display while its [AUTO] button is pressed.

Pro Tools	Channel Strip Displays	[AUTO] Button Indicators
Auto trim/write	TWrt	Flashing red/orange (Record Ready) Orange (Recording)
Auto trim/touch	TTch	
Auto trim/latch	TLch	
Auto trim/read	TRd	Flashing green/orange

Grouped channels are set together. You can temporarily disable a group in order to set individual channels by pressing and holding the USER DEFINED KEYS [12] (CTRL/CLUTCH) button.

The following shortcuts apply.

To do this...	Do this!
Set Trim mode for all channels	USER DEFINED KEYS [5] + AUTOMIX [RELATIVE]
Set Trim mode of all selected channels	USER DEFINED KEYS [5] + USER DEFINED KEYS [4] + AUTOMIX [RELATIVE]

In Trim mode, you can display channel and send level values relatively (instead of absolute decibel values) on the channel strip displays by holding down the USER DEFINED KEYS [13] (ALT/FINE) button while adjusting the faders and Encoders.

## Arming Parameters for Automation

Parameters can be selected for automation recording as follows.

- 1 **Use the following AUTOMIX-OVERWRITE buttons to arm parameters.**

AUTOMIX-OVERWRITE Buttons	Pro Tools
[FADER] (FADER)	Volume
[ON] (MUTE)	Mute
[PAN] (PAN)	Pan
[AUX] (SEND)	Send level
[AUX ON] (SEND MUTE)	Send mute
[EQ] (PLUG-IN)	Plug-in

The button indicators for armed parameters light up.

The following shortcuts apply.

To do this...	Do this!
Arm all parameters	USER DEFINED KEYS [5] + AUTOMIX-OVERWRITE [FADER], [ON], [PAN], [AUX], [AUX ON], or [EQ]
Inverse armed parameter selection	USER DEFINED KEYS [13] + AUTOMIX-OVERWRITE [FADER], [ON], [PAN], [AUX], [AUX ON], or [EQ]

## Panner

### Selecting a Track

Use the SELECTED CHANNEL ROUTING buttons to manipulate the following track operations.

To do this...	Use these buttons:
Selecting the previous track	ROUTING [1] button
Selecting the next track	ROUTING [2] button
Selecting the top track	ROUTING [3] + [1] buttons
Selecting the last track	ROUTING [3] + [2] buttons
Selecting the main output of the selected track	ROUTING [3] + [5] buttons
Selecting Send 5 of the selected track	ROUTING [3] + [7] buttons
Selecting the output/send of the selected track	ROUTING [5] + [7] buttons

### Stereo Track Link

You can control the panner for the L and R channels of stereo tracks simultaneously or individually, depending on the stereo link status.

To cancel the stereo panner link, press and hold down the [Control] key on the keyboard and move the Joystick.

### Panner Operation via the Joystick

- 1 **Select the track you wish to pan.**
- 2 **Press the [GRAB] button, turning on the [GRAB] button indicator.**
- 3 **While the [GRAB] button indicator is lit, operate the Joystick.**

If you move the Joystick for direct panning while the [GRAB] button indicator is lit, the pan position is specified as an absolute value, which may cause the pan position to jump drastically.

You can also restrict the trajectory direction of the Joystick. To limit movement to the L and R directions, press and hold down the [DIRECT] button and move the Joystick. To limit movement to the up and down (front and rear) directions, select 3 Knob mode in the Pro Tools Panner window.

### Panner Operation via Knob Controls

You can control the following parameters using the DYNAMICS controls.

Controls	ROUTING [6] indicator is off	ROUTING [6] indicator is on
THRESHOLD	Front position	Front divergence
RANGE/RATIO	Rear position	Rear divergence
ATTACK	F/R position	F/R divergence
DECAY/RELEASE	LFE level	Center percentage
HOLD/GAIN	Channel volume	

- 1 **Select the track and output, if desired.**
- 2 **Press the ROUTING [6] button to select the knob control mode that is appropriate for the parameter you wish to control.**
- 3 **Use the appropriate control to adjust the parameter.**

Pressing and holding down the [Command] key on the keyboard and rotating the controls reduces the change in the parameter values.

## 20 Remote Control

### About Remote Layers

The DM2000's four Remote Layers allow you to control external MIDI equipment directly from the DM2000. The type of device to be controlled (i.e., the target) can be specified for each Remote Layer. There are six types of target: User Defined, Pro Tools, Nuendo, Cubase SX, General DAW, and User Assignable Layer. User Defined targets allow you to specify the MIDI data that will be transmitted when the 24 channel strip faders, Encoders, and [ON] buttons are operated. These settings are stored in Scenes, for snapshot-style automation. The Pro Tools, Nuendo, Cubase SX, and General DAW targets use a specially designed protocol that supports Pro Tools, Nuendo, Cubase SX, and other DAW software protocols.

The User Assignable Layer target enables you to combine DM2000 channels to create a custom layer. See page 269 for more information on the User Assignable Layer.

### Assigning Targets to Remote Layers

Targets are assigned to Remote Layers as follows.

- 1 Use the **DISPLAY ACCESS [REMOTE]** button to locate the Remote 1–4 pages.

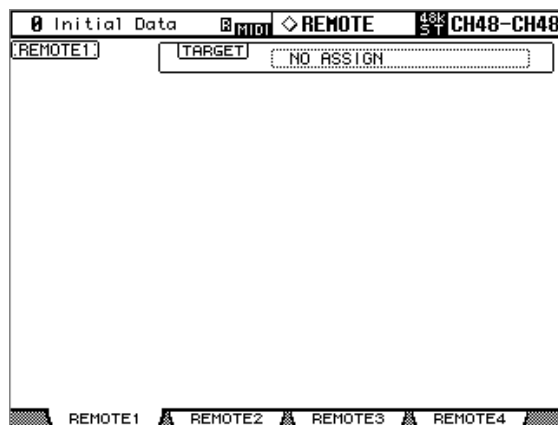

- 2 Use the cursor buttons to select the **TARGET** parameter, use the Parameter wheel or INC/DEC buttons to select a target, and then press [ENTER].

**TARGET:** This can be set to NO ASSIGN, USER DEFINED, Pro Tools, Nuendo, Cubase SX, General DAW, or User Assignable Layer. Only one Remote Layer can be set to Pro Tools, Nuendo, Cubase SX, or General DAW. See page 254 for more information on the User Defined target. See page 221 for more information on the Pro Tools target. See page 269 for more information on the User Assignable Layer.

To control Nuendo or Cubase SX remotely, make the following settings in addition to the TARGET parameter.

- 3 Select the desired port for the DAW parameter on the MIDI/To Host Setup page (see page 216).
- 4 Select an appropriate device in the Device menu of Nuendo or Cubase SX and specify the DM2000 as a controller.

For more information on the necessary settings, refer to the Owner's Manual that came with Nuendo or Cubase SX.

## Configuring User Defined Remote Layers

User Defined Remote Layers can be configured as follows.

- 1 Use the DISPLAY ACCESS [REMOTE] button to locate the Remote 1–4 pages.

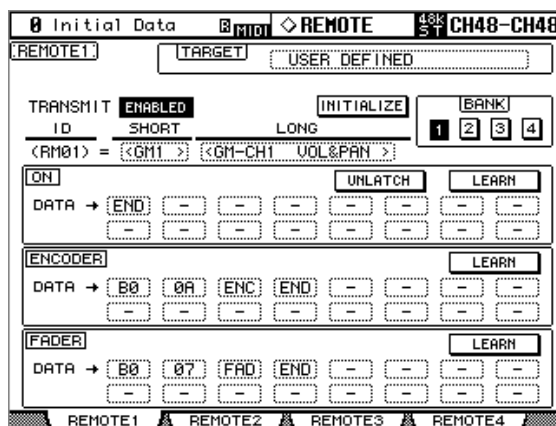

- 2 Use the cursor buttons to select the parameters, and use the Parameter wheel, INC/DEC buttons, and [ENTER] button to set them.

**TARGET:** This is used to select the target for the currently selected Remote Layer (the User Defined target is explained here).

**TRANSMIT:** This enables and disables MIDI data transmission for the selected Remote Layer.

**INITIALIZE:** This initializes the settings of the currently selected bank.

**BANK:** These buttons are used to select banks 1, 2, 3, and 4. Each bank can contain MIDI settings for the 24 faders, Encoders, and [ON] buttons. Banks can be stored to an external MIDI device, such as a MIDI data file, by using MIDI Bulk Dump (see page 220), or stored to SmartMedia (see page 271). Initially, bank 1 contains General MIDI (GM) volume and pan settings; bank 2, GM volume and effect; bank 3, XG volume and pan; bank 4, Nuendo VST mixer.

**ID/SHORT/LONG:** On Remote Layers, channel strips 1–24 are identified by the fixed IDs RM01–RM24. You can enter a Short and Long name for each Remote channel strip. Short names appear on the channel strip displays. To enter a name, use the cursor buttons to select the SHORT or LONG name, use the [SEL] buttons, Parameter wheel, or INC/DEC buttons to select the channel strips, and then press [ENTER]. When the Title Edit window appears, enter a name, and press OK when you've finished. See "Title Edit Window" on page 54 for more information.

**ON:** These parameters are used to specify the MIDI message (up to 16 bytes) to be transmitted when an [ON] button is pressed. Use the [SEL] buttons to select the channel strips, and then edit as necessary. When a value from 00 to FF is specified, that value is transmitted when an [ON] button is pressed. For the SW setting, data value 7F is transmitted when an [ON] button is turned on, and data value 00 is transmitted when an [ON] button is turned off. The END setting specifies the end of the data. "–" means no data is transmitted.

**UNLATCH/LATCH:** This parameter determines the operation of the [ON] buttons: Latching or Non-latching. When set to UNLATCH, an ON value is transmitted when an buttons is pressed, and an OFF value is transmitted when it's released. When set to LATCH, an ON value is transmitted when the button is pressed and that value is maintained when the button is released. The next time you press that button, the OFF value is transmitted.

**LEARN:** This button is used to turn on and off the Learn function, which can be used to learn what MIDI messages are being transmitted by external MIDI devices when their controls or parameters are adjusted. When on, received MIDI messages are displayed in the DATA area. Only the first 16 bytes of data, starting with a Status bit, are displayed.

**ENCODER:** These parameters are used to specify the MIDI message (up to 16 bytes) to be transmitted when an Encoder is operated. Use the [SEL] buttons to select the channel strips, and then edit as necessary. When a value from 00 to FF is specified, that value is transmitted when an Encoder is adjusted. For the ENC setting, the Encoder’s current value from 0–127 is transmitted when it’s adjusted. The END setting specifies the end of the data. “–” means no data is transmitted.

**LEARN:** This works the same as the [ON] button Learn function above, except the received MIDI messages are displayed in the ENCODER DATA area. Only one Learn function can be used at a time.

**FADER:** These parameters are used to specify the MIDI message (up to 16 bytes) to be transmitted when a fader is operated. Use the [SEL] buttons to select the channel strips, and then edit as necessary. When a value from 00 to FF is specified, that value is transmitted when a fader is adjusted. For the FAD setting, a fader’s current value from 0–127 is transmitted when it’s adjusted. The END setting specifies the end of the data. “–” means no data is transmitted.

**LEARN:** This works the same as the [ON] button Learn function above, except the received MIDI messages are displayed in the FADER DATA area. Only one Learn function can be used at a time.

### Using User Defined Remote Layers

Once configured, User Defined Remote Layers can be used as follows.

- 1 Use the LAYER REMOTE [1–4] buttons to select the User Defined Remote Layers.

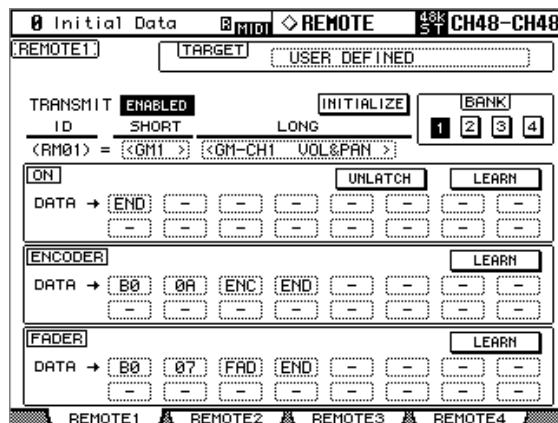

While a User Defined Remote Layer is selected, operating the channel strip faders, Encoders, and [ON] buttons causes the specified MIDI data to be transmitted.

When a User Defined Remote Layer is selected, the corresponding Remote page appears. Since this is the same page as that selected by the DISPLAY ACCESS [REMOTE] button, User Defined Remote Layers can be configured here as well, even the target can be changed.

When a User Defined Remote Layer is selected, the channel strip displays show Remote channel strip Short names. The border of the currently selected channel’s channel strip display lights up. The Encoder displays indicate the positions of the Encoders.



The settings of the channel strip faders, Encoders, and [ON] buttons, and the current target and bank setting for each Remote Layer are stored in Scenes. When a Scene is recalled, if the Remote Layer’s target is the same as when the Scene was stored, the faders, Encoders, and [ON] buttons are set accordingly and the corresponding MIDI data is transmitted (so long as the TRANSMIT parameter is set to ENABLED). If the target is not the same, the faders, Encoders, and [ON] buttons are set accordingly, but no MIDI data is transmitted.

## About Machine Control (MMC & P2)

The DM2000 can control the transport, locate functions, track arming, and chase function of up to eight external recording machines that support the MMC or P2 control protocol. Machines can be specified as either MTR or Master and controlled independently.

Machines that support the P2 protocol can be controlled by connecting them to the DM2000's REMOTE port using a 9-pin straight cable. Wiring details are provided on page 350. The REMOTE port must be set for P2 control on the Remote Port Setup page (see page 257).

Machines that support MMC can be controlled by connecting them to the DM2000's MIDI, SERIAL, USB, or SLOT1 (with optional mLAN I/O Card installed in Slot #1).

MMC and P2 protocol support varies from machine to machine. Some machines may not operate exactly as explained in this section.

## Configuring Machines

Up to eight machines can be configured as follows.

- 1 Use the LOCATOR [DISPLAY] button to locate the Machine Configuration page.

MACHINE	TYPE	PORT	DEVICE ID	TRANSPORT CONTROL	CHASE CONTROL	MASTER/MTR
1	NONE	-	-	DISABLED	DISABLED	MTR
2	NONE	-	-	DISABLED	DISABLED	MTR
3	NONE	-	-	DISABLED	DISABLED	MTR
4	NONE	-	-	DISABLED	DISABLED	MTR
5	NONE	-	-	DISABLED	DISABLED	MTR
6	NONE	-	-	DISABLED	DISABLED	MTR
7	NONE	-	-	DISABLED	DISABLED	MTR
8	NONE	-	-	DISABLED	DISABLED	MTR

- 2 Use the cursor buttons to select the parameters, and use the Parameter wheel, INC/DEC buttons, and [ENTER] button to set them.

**MACHINE CONTROL/DAW CONTROL:** When the MACHINE CONTROL option is on, the MACHINE CONTROL section controls external MMC machines, regardless of the layer selection. When the DAW CONTROL option is on, the MACHINE CONTROL section controls DAWs, regardless of the layer selection.

**TYPE:** This is used to specify the type of machine: MMC or P2. Only one machine can be set to P2.

**PORT:** When the machine TYPE is MMC, use this parameter to specify the port for MMC communications. Available ports include: MIDI, SERIAL 1–8, USB 1–8, and SLOT1.

**DEVICE ID:** When the machine TYPE is MMC, use this parameter to specify the device ID from 1 to 127 or ALL. The target machine must be set to the same ID. The same ID cannot be assigned to more than one SERIAL, USB, or SLOT1 port.

**TRANSPORT CONTROL:** This parameter determines whether or not the DM2000's transport buttons control the machine. Only one Master and one MTR machine can be enabled at a time.

**CHASE CONTROL:** This parameter determines whether or not a Chase On/Off command is transmitted from the DM2000 to a machine when the LOCATOR [ONLINE] button is pressed.

**MASTER/MTR:** This parameter is used to specify which machines are Masters and which are MTRs. Multiple machines can be set to Master and MTR.



## Configuring the REMOTE Port

REMOTE

If you are using the P2 protocol to control a machine, the REMOTE port must be configured as follows.



- 1 Use the **DISPLAY ACCESS [SETUP]** button to select the Remote Port Setup page.

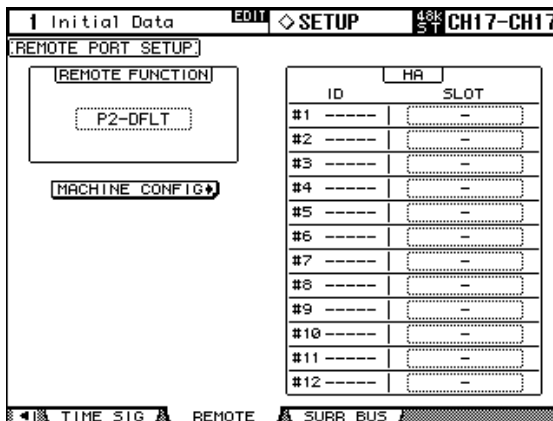

- 2 Use the cursor buttons to select the **REMOTE FUNCTION** parameter, use the **INC/DEC** buttons to select **P2-DFLT**, then press **[ENTER]**.

**P2-DFLT:** A P2 protocol used by the Tascam DA-98HR and other professional video machines.

**HA:** A protocol used to control Yamaha AD8HR/AD824 A/D converters.

**P2-VTR1-3:** An expanded version of the P2 protocol intended for future use. Currently, this is the same as P2-DFLT.

## Transport Buttons

The DM2000's transport can be used to control external machines. Transport control can be enabled and disabled for individual machines on the Machine Configuration page (see page 256).

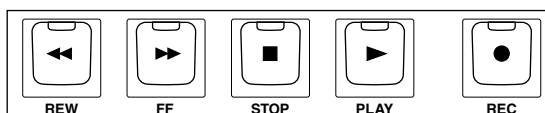

### [REW] button

This button starts rewind on the external machines.

### [FF] button

This button starts fast forward on the external machines.

### [STOP] button

This button stops the external machines.

### [PLAY] button

This button starts playback on the external machines. It's also used to punch out of recording.

### [REC] button

This button is used in conjunction with the [PLAY] button to start recording on the external machines.

## Using Shuttle & Scrub

The Parameter wheel can be used to shuttle and scrub the external machines.

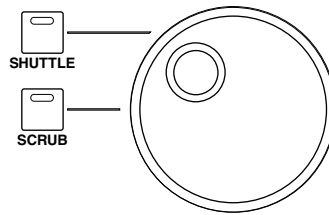

When the [SHUTTLE] button indicator is lit, the Parameter wheel can be used to shuttle. When the [SCRUB] button indicator is lit, the Parameter wheel can be used to scrub. Turn the Parameter wheel clockwise to shuttle/scrub forwards. Turn it counterclockwise to shuttle/scrub backwards.

## Using the Locator

The LOCATOR section can be used to control the external machines.

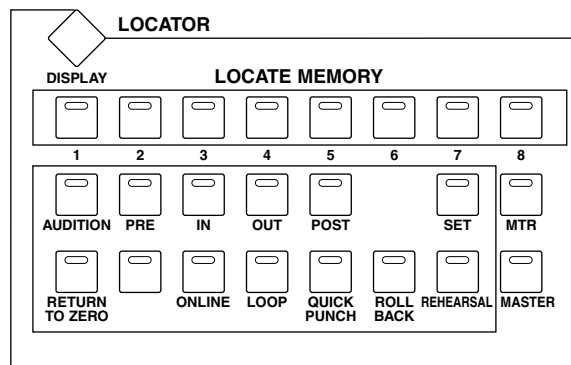

### LOCATE MEMORY [1–8] buttons

These buttons are used to set and to locate to the eight Locate memories. Locate memories can be set on the Locate Memory page (see page 260). To set a locate memory on-the-fly, while holding down the [SET] button, press a LOCATE MEMORY [1–8] button. The DM2000 must be receiving timecode in order to do this. Once set, the stored position can be located by pressing the corresponding button. If the button is pressed while the machine is stopped, the stored position is located. If the button is pressed while the machine is playing, the stored position is located and then playback continues from that position.

When using P2, locate operations are based on the control information received at the REMOTE port. In order to synchronize the MB2000 Peak Meter Bridge's time counter, it's recommended that you set the DM2000 to the same timecode source as the machine.

### [AUDITION] button

This button is used in conjunction with the [PRE], [IN], [OUT], and [POST] buttons for auditioning. Its indicator lights up while auditioning is on and operation is as follows:

- Press the [PRE] button to locate and audition from the pre-roll point.
- Press the [IN] button to locate and audition from the in point.
- Press the [OUT] button to locate and audition from the out point.
- Press the [POST] button to locate and audition from the post-roll point.

### [PRE] & [POST] buttons

These buttons are used to locate the pre-roll and post-roll points. If the [AUDITION] button indicator is lit, playback starts when a point is located. The pre-roll point is the in point minus the specified pre-roll time. The post-roll point is the out point plus the specified

post-roll time. The pre-roll and post-roll times can be specified on the Locate Memory page (see page 260). If a button is pressed while the machine is stopped, the stored position is located. If a button is pressed while the machine is playing, the stored position is located and then playback continues from that position.

### **[IN] & [OUT] buttons**

These buttons are used to set and to locate the in and out points. These points can be set on the Locate Memory page (see page 260). To set a point on-the-fly, while holding down the [SET] button, press the [IN] or [OUT] button. The DM2000 must be receiving timecode in order to do this. Once set, the stored position can be located by pressing the corresponding button. If the button is pressed while the machine is stopped, the stored position is located. If the button is pressed while the machine is playing, the stored position is located and then playback continues from that position. If the [AUDITION] button indicator is lit, playback starts when a point is located.

### **[SET] button**

This button is used in conjunction with the LOCATE MEMORY [1–8], [IN], [OUT], and [RETURN TO ZERO] buttons to set the locate points.

### **[RETURN TO ZERO] button**

This button is used to set and to locate the return to zero point. This point can be set on the Locate Memory page (see page 260). To set it on-the-fly, while holding down the [SET] button, press the [RETURN TO ZERO] button. The DM2000 must be receiving timecode in order to do this. Once set, the stored position can be located by pressing the [RETURN TO ZERO] button. If the button is pressed while the machine is stopped, the stored position is located. If the button is pressed while the machine is playing, the stored position is located and then playback continues from that position.

### **[ONLINE] button**

This button is used to switch the external machines online and offline. Its indicator lights up when machines are online. Essentially, this turns the machine's chase function on and off. This function can be enabled and disabled for individual machines on the Machine Configuration page (see page 256).

When chase is on, the machine automatically chases its specified timecode source, and the following DM2000 controls are ineffective: transport, [SHUTTLE], [SCRUB], [PRE], [POST], [IN], [OUT], [RETURN TO ZERO], [LOOP], and [QUICK PUNCH].

### **[LOOP] button**

This button is used to turn loop playback on and off, in which playback cycles between the pre-roll and post-roll points. Its indicator lights up when loop playback is on. If Loop playback is turned on during playback, loop playback will not start until the post-roll point is reached.

This button is mutually exclusive with the [QUICK PUNCH], [SHUTTLE], and [SCRUB] buttons.

### **[QUICK PUNCH] button**

This button is used to turn quick punch (also known as auto punch) on and off. Its indicator lights up when quick punch is on.

This button is mutually exclusive with the [LOOP], [SHUTTLE], and [SCRUB] buttons.

- When the [QUICK PUNCH] button indicator is lit, pressing the [PLAY] button will locate to the pre-roll point and start playback. At the post-roll point, the machine will stop playback, locate the pre-roll point, and then stop.
- When the [QUICK PUNCH] button indicator is lit, pressing the [PLAY] and [REC] buttons together will locate to the pre-roll point and start playback. At the in point, the

machine switches to input monitor and starts recording. At the out point, the machine switches to playback monitor and stops recording. At the post-roll point, the machine locates the pre-roll point and then stops. If the [REHEARSAL] button indicator is lit, the machine goes into Record-Rehearsal mode between the in and out points (i.e., nothing is recorded).

**[ROLL BACK] button**

This button is used to roll back the machine by the amount specified on the Locate Memory page (see page 260). If its pressed while the machine is stopped, the machine rolls back the specified amount and stops. If its pressed during playback, the machine rolls back the specified amount and then continues playing.

**[REHEARSAL] button**

This button is used to turn Rehearsal mode on and off. Its indicator lights up when Rehearsal mode is on. In Rehearsal mode, the machine enters Record-Rehearsal mode instead of actually recording when the [PLAY] and [REC] buttons are pressed together. Rehearsal mode can also be used with quick punch.

**[MTR] & [MASTER] buttons**

These mutually exclusive buttons are used to select the MTR or Master machines for control with the LOCATOR section. When the [MTR] button indicator is lit, the LOCATOR section controls machines set to MTR. When the [MASTER] button indicator is lit, the LOCATOR section controls machines set to MASTER. See “Configuring Machines” on page 256.

**Setting the Locate Memories, Pre-roll, Post-roll & Roll-back**

The locate points and the pre-roll, post-roll, and roll-back times can be set as follows.

- 1 Use the LOCATOR [DISPLAY] button to locate the Locate Memory page.

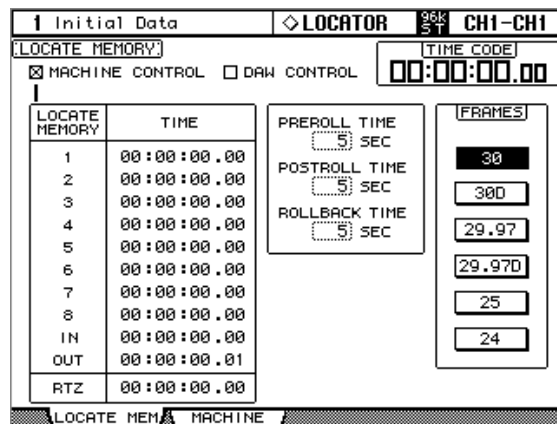

- 2 Use the cursor buttons to select the parameters, and use the Parameter wheel, INC/DEC buttons, and [ENTER] button to set them.

**MACHINE CONTROL/DAW CONTROL:** When the MACHINE CONTROL option is on, the MACHINE CONTROL section controls external MMC machines, regardless of the layer selection. When the DAW CONTROL option is on, the MACHINE CONTROL section controls DAWs, regardless of the layer selection.

**LOCATE MEMORY 1–8, IN, OUT, and RTZ:** These time values determine the points that will be located when the LOCATOR [1–8], [IN], [OUT], and [RTZ] buttons are pressed. Locate points can be specified in hours, minutes, seconds, and frames, the frame range being dependent on the frame rate setting on the Time Reference page (see page 201). These points can also be set on-the-fly, so long as the DM2000 is receiving timecode. To do this, while holding down the LOCATOR [SET] button, press the [1–8], [IN], [OUT], or [RTZ] button.

**PREROLL TIME:** In conjunction with the in point, this determines the position that will be located when the LOCATOR [PRE] button is pressed. For example, if the in point is 00:01:00.00 and the pre-roll time is 5 seconds, 00:00:55.00 will be located.

**POSTROLL TIME:** In conjunction with the out point, this determines the position that will be located when the LOCATOR [POST] button is pressed. For example, if the out point is 00:01:00.00 and the post-roll time is 5 seconds, 00:01:05.00 will be located.

**ROLLBACK TIME:** This determines how many seconds the machines roll back from the current position when the LOCATOR [ROLL BACK] button is pressed.

**FRAMES:** This parameter selects the timecode frame rate.

## Arming Machine Tracks

The TRACK ARMING section can be used to arm tracks on external machines.

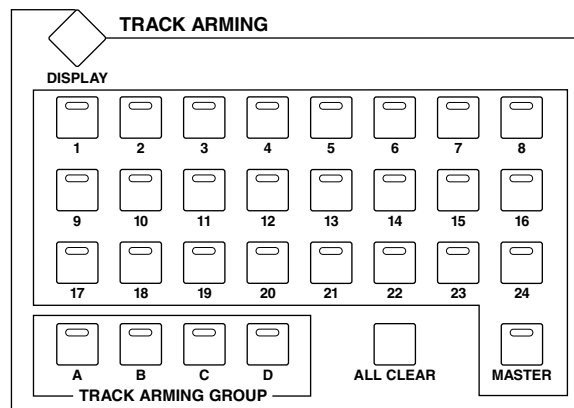

### [1–24] buttons

These buttons are used to arm tracks on the external MTR and Master machines. Their indicators light up when tracks are armed. These buttons can be configured to arm any track of any machine. See “Configuring MTR Track Arming” on page 262 and “Configuring Master Track Arming” on page 262 for more information.

### TRACK ARMING GROUP [A–D] buttons

These buttons are used to select track arming groups A, B, C, and D. The indicator of the currently selected group lights up. See “Configuring Track Arming Groups” on page 263 for more information.

### [ALL CLEAR] button

This button is used to clear all track arming on the external machines.

### [MASTER] button

This button is used to select the MTR or Master machines for track arming. When its button indicator is off, the TRACK ARMING section controls machines set to MTR. When the button indicator is lit, the TRACK ARMING section controls machines set to MASTER. See “Configuring Machines” on page 256.

### Configuring MTR Track Arming

You can assign MTR machine tracks to the TRACK ARMING [1–24] buttons as follows. These assignments are effective only when the TRACK ARMING [MASTER] button indicator is off.

- 1 Use the TRACK ARMING [DISPLAY] button to locate the MTR Track Arming Configuration page.

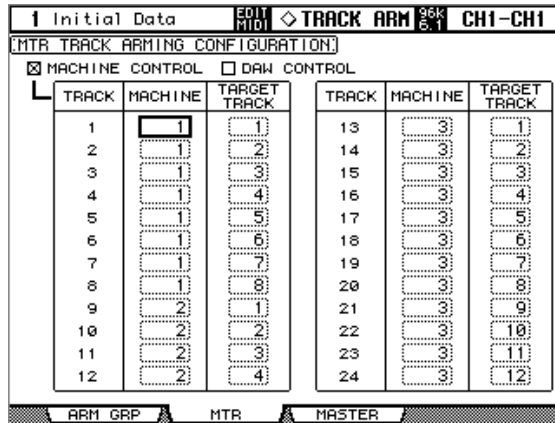

- 2 Use the cursor buttons to select the parameters, and use the Parameter wheel, INC/DEC buttons, and [ENTER] button to set them.

**MACHINE CONTROL/DAW CONTROL:** When the MACHINE CONTROL option is on, the MACHINE CONTROL section controls external MMC or P2 machines, regardless of the layer selection. When the DAW CONTROL option is on, the MACHINE CONTROL section controls DAWs, regardless of the layer selection.

**MACHINE:** This parameter is used to specify the MTR machine whose track is to be armed when each TRACK ARMING button is pressed. Only machines configured as MTRs on the Machine Configuration page (see page 256) can be selected.

**TARGET TRACK:** This parameter is used to specify the MTR machine track that is to be armed when each TRACK ARMING button is pressed.

### Configuring Master Track Arming

You can assign Master machine tracks to the TRACK ARMING [1–24] buttons as follows. These assignments are effective only when the TRACK ARMING [MASTER] button indicator is lit.

- 1 Use the TRACK ARMING [DISPLAY] button to locate the Master Track Arming Configuration page.

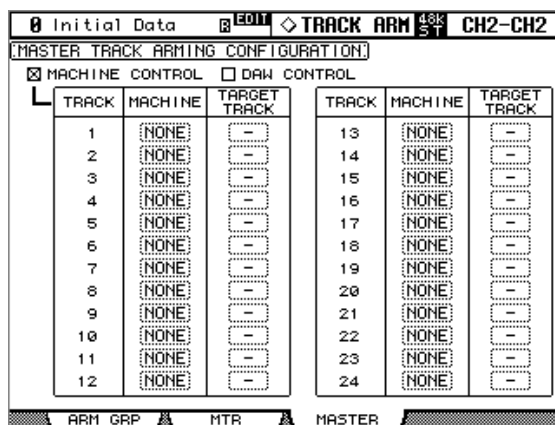

- 2 Use the cursor buttons to select the parameters, and use the Parameter wheel, INC/DEC buttons, and [ENTER] button to set them.

**MACHINE CONTROL/DAW CONTROL:** When the MACHINE CONTROL option is on, the MACHINE CONTROL section controls external MMC or P2 machines, regardless of the layer selection. When the DAW CONTROL option is on, the MACHINE CONTROL section controls DAWs, regardless of the layer selection.

**MACHINE:** This parameter is used to specify the Master machine whose track is to be armed when each TRACK ARMING button is pressed. Only machines configured as Masters on the Machine Configuration page (see page 256) can be selected.

**TARGET TRACK:** This parameter is used to specify the Master machine track that is to be armed when each TRACK ARMING button is pressed.

## Configuring Track Arming Groups

Track arming groups A, B, C, and D provide a quick way to arm multiple MTR or Master machine tracks.

- 1 Use the TRACK ARMING [DISPLAY] button to locate the Track Arming Group page.

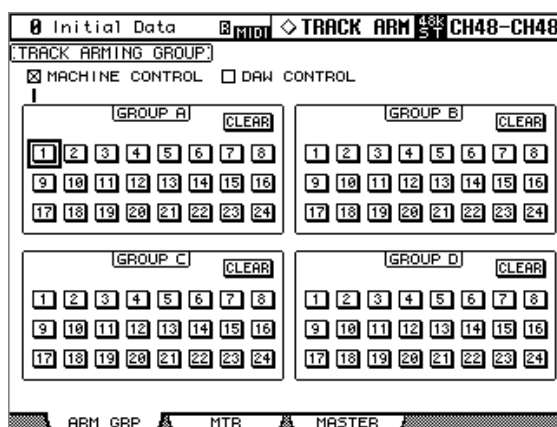

- 2 Use the cursor buttons or Parameter wheel to select the track buttons, and use the INC/DEC buttons or [ENTER] button to add and remove tracks from the groups.

A track is in a group when its button appears highlighted, and tracks can be in multiple groups. The CLEAR buttons can be used to clear all assignments in each group.

When a TRACK ARMING GROUP [A–D] button is pressed, that button's indicator, and the button indicators of the tracks in that group light up. If one of those tracks is subsequently unarmed, the TRACK ARMING GROUP [A–D] button indicator goes out.

**MACHINE CONTROL/DAW CONTROL:** When the MACHINE CONTROL option is on, the MACHINE CONTROL section controls external MMC or P2 machines, regardless of the layer selection. When the DAW CONTROL option is on, the MACHINE CONTROL section controls DAWs, regardless of the layer selection.

## GPI (General Purpose Interface)

The DM2000’s CONTROL port (25-pin D-sub connector) provides a GPI (General Purpose Interface). You can configure the GPI so that it will output 8-channel trigger signals when you operate the faders or User Defined Keys, or receive 2-channel trigger signals to control DM2000 parameters.

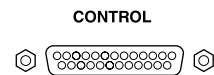

You can assign any function to these trigger signals. In this way, for example, you can control a “RECORDING” warning light outside a studio from the DM2000, or you can control the DM2000’s Talkback function or Dimmer function using an outside switch.

See page 350 for more information on pin assignment.

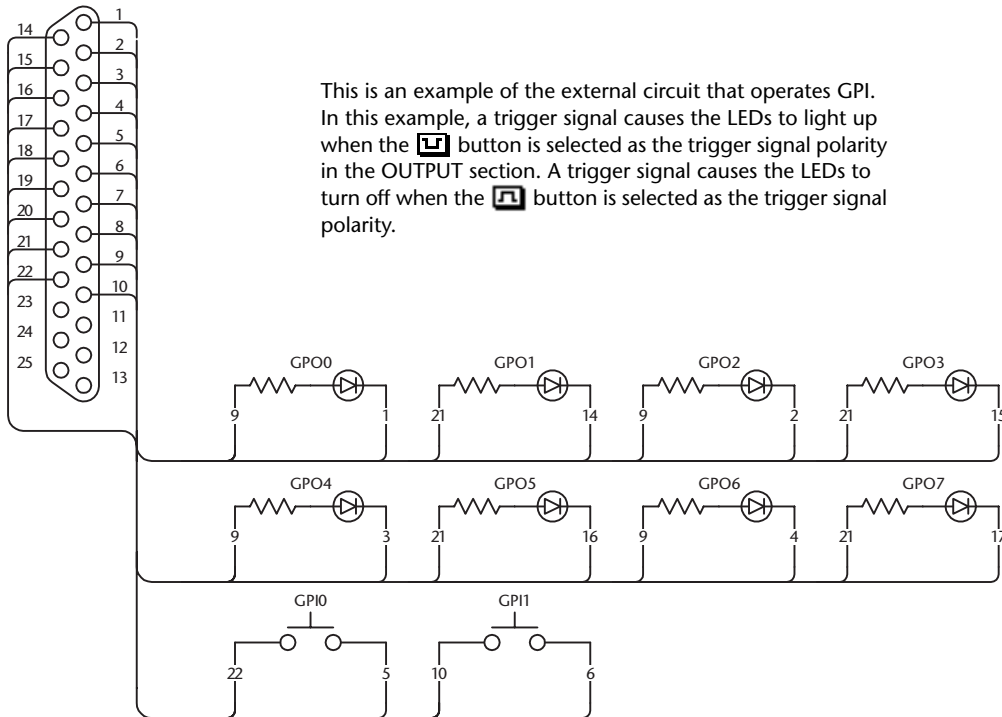

- 1 Use the DISPLAY ACCESS [SETUP] button to select the GPI Setup page.

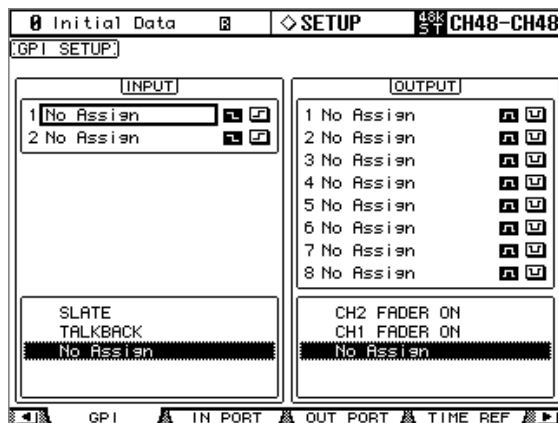

- 2 To assign functions to incoming trigger signals, use the cursor buttons to select INPUT 1 or 2.
- 3 Use the Parameter wheel or INC/DEC buttons to select a parameter, then press [ENTER].



**4 Select one of two buttons located to the right of trigger signal parameters INPUT 1 & 2 to specify how the incoming trigger signals will be detected.**

: When the switch is grounded (Low), the trigger signal is active and the selected parameter changes.

: When the GPI Input goes High (open), the trigger signal is active and the selected parameter changes.

You can execute functions assigned to the MONITOR section buttons and User Defined Keys, and turn channels on and off. See “GPI Trigger Source & Target List” on page 302 for a complete list of assignable functions.

*Note: “xxx UNLATCH” means that the assigned function is enabled only while the incoming trigger signal is active. For example, if CH1 ON is selected, the channel on/off status changes each time the trigger signal is detected. If CH1 ON UNLATCH is selected, Channel 1 turns on only while the trigger signal is active.*

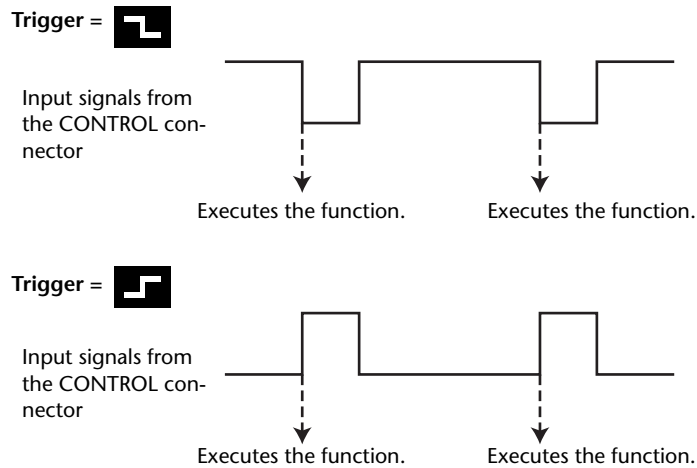

At this point, when the DM2000 receives the trigger signal at the CONTROL connector, the selected parameter changes.

*Tip: Refer to the page 302 for a complete list of assignable parameters.*

- TALKBACK - SMALL:** Functions the same as the MONITOR section buttons.
- SR xxx:** Functions the same as the SURROUND buttons in the MONITOR section.
- CR xxx:** Functions the same as the CONTROL ROOM buttons in the MONITOR section.
- SM xxx:** Functions the same as the STUDIO buttons in the MONITOR section.
- xxx UNLATCH:** The assigned function is enabled only while the incoming trigger signal is active.
- xxx ON:** The corresponding channels turn on or off each time the incoming trigger signal becomes active.
- xxx ON UNLATCH:** The corresponding channels turn on only while the incoming trigger signal is active.
- UDEFxxx:** Functions the same as the USER DEFINED KEYS.

**5 To select parameters or controls as trigger signal sources, use the cursor buttons to select an output from OUTPUT 1–8, then select trigger signal parameters as you would for the INPUT section.**

See “GPI Trigger Source & Target List” on page 302 for a complete list of assignable parameters.

- 6 Use the buttons located to the right of the OUTPUT (1–8) parameters to switch the polarity of the trigger signals that are output when you control the trigger sources.

: The GPI Output goes High (open) when the trigger signal source is active.

: The GPI Output goes Low (ground) when the trigger signal source is active.

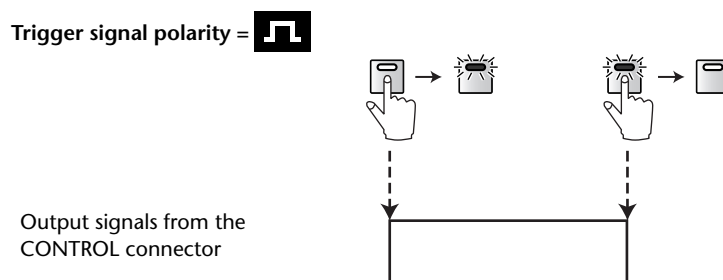
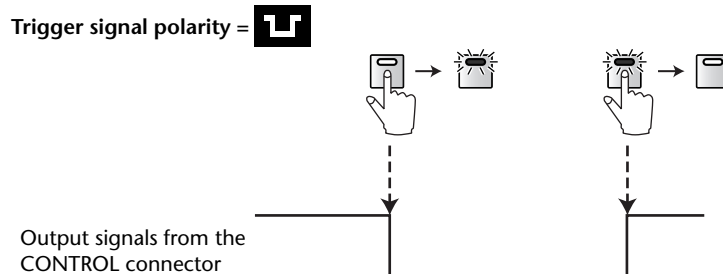

At this time, the trigger signal is output from the CONTROL connector when you operate the assigned parameters or controls.

*Tip: Refer to page 302 for a complete list of assignable parameters and controls.*

**xxx FADER ON:** A trigger signal of 250 ms is transmitted when you raise a fader from  $-\infty$ .

**xxx FADER OFF:** A trigger signal of 250 ms is transmitted when you lower a fader to  $-\infty$ .

**xxx FADER TALLY:** The trigger signal becomes active when the fader is set to any level other than  $-\infty$ , and the trigger signal turns off when the fader is set to  $-\infty$ .

**UDEFxx LATCH:** Pressing the corresponding button in the USER DEFINED KEYS section activates the trigger signal, and pressing the button again turns it off.

**UDEF xx UNLATCH:** A trigger signal of 250 ms is transmitted each time you press the corresponding button in the USER DEFINED KEYS section.

**REC LAMP:** This source can be used to control a “RECORDING” warning light outside a studio. The trigger signal is active while the [REC] button indicator is lit.

**POWER ON:** The trigger signal is active while the power to the DM2000 is on.

*Important note: GPI outputs are open collector outputs. GPI inputs have an internal pull-up to 5 V.*

## Controlling AD8HR/AD824 A/D Converters

You can control the parameters of up to 12 Yamaha AD8HR/AD824 A/D Converters from the DM2000 by connecting them to the DM2000's REMOTE port using a 9-pin reversed cable. Pinouts are provided on page 350.

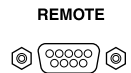

### Configuring the REMOTE Port & Assigning Slots to HA (AD8HR/AD824) IDs

The REMOTE port can be configured, and Slots assigned to HA IDs as follows.

- 1 Use the DISPLAY ACCESS [SETUP] button to select the Remote Port Setup page.

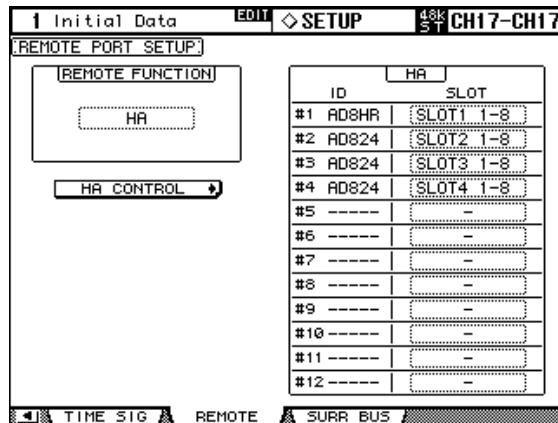

- 2 Use the cursor buttons to select the REMOTE FUNCTION button, use the INC/DEC buttons to select HA, then press [ENTER].
- 3 Use the cursor buttons to select the HA SLOT parameters, and use the Parameter wheel or INC/DEC buttons to select the Slots.

The ID column lists names of connected devices (AD8HR or AD824). The number of available IDs depends on the number of AD8HR/AD824s connected to the DM2000.

*Note: To control multiple AD8HR/AD824 Converters, connect them with the DM2000 in a daisy chain. Note that you must connect AD8HRs closer to the DM2000 if both AD8HRs and AD824s are connected in a system.*

## Controlling AD8HR/AD824s from the DM2000

Connected AD8HR/AD824s are controlled from the HA Control page.

- 1 Use the **SELECTED CHANNEL PHASE/INSERT [DISPLAY]** button to select the HA Control page.

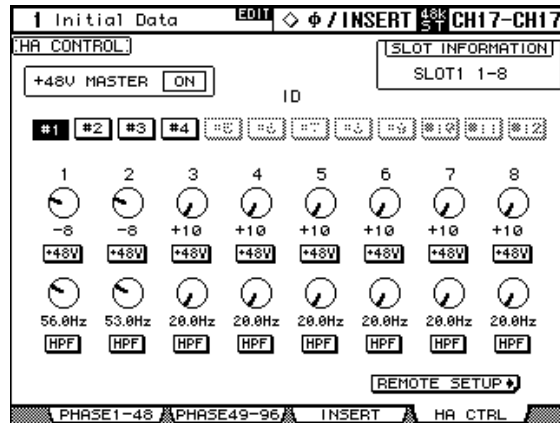

- 2 Use the cursor buttons to select the ID of the HA (AD8HR/AD824) that you want to control, and then press [ENTER].
- 3 Use the rotary controls to set the gain of each HA channel, and use the +48V buttons to turn phantom power on or off for each channel.

If you connected an AD8HR, you can monitor the +48V MASTER switch on/off status on the AD8HR.

- 4 If you connected an AD8HR, turn the rotary controls to set the HPF (high pass filter) cutoff frequency for each HA channel, and use the HPF buttons to turn HPF on or off for each channel.

All parameter settings, excluding the phantom power on/off setting, will be saved as part of a scene.

## 21 Other Functions

### Using the User Assignable Layers

If you set the Remote layer target to “USER ASSIGNABLE,” you can create a custom layer by combining any DM2000 channels (excluding the Stereo Out).

- 1 Use the **DISPLAY ACCESS [REMOTE]** button to locate Remote 1–4 page.

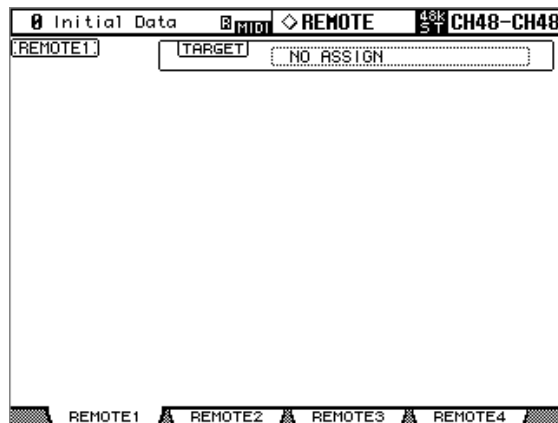

- 2 Use the cursor buttons to select the **TARGET** parameter, use the Parameter wheel or INC/DEC buttons to select **USER ASSIGNABLE LAYER**, then press [ENTER].

A confirmation message appears. Select the YES button and press [ENTER].

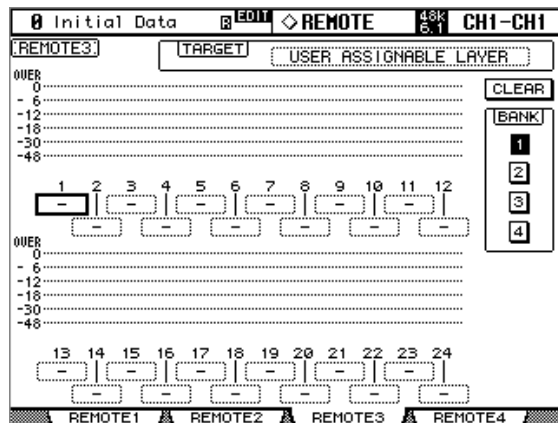

- 3 Use the cursor buttons to select parameter 1–24, use the Parameter wheel or INC/DEC buttons to select a channel you want to assign, then press [ENTER].

You can store up to four 24-channel setups in four banks by switching Banks 1–4 via the BANK 1–4 buttons.

Pressing the [ENTER] button prior to selecting assigned channels enables you to select a channel in the User CH Select window.

- 4 Use the **LAYER [REMOTE 1]–[REMOTE 4]** button to recall the User Assignable layer assigned to the Remote layer.

You can use the faders, Encoders, [ON] buttons, [AUTO] buttons, and [SOLO] buttons to control assigned channels. If you connected an optional MB2000 Meter Bridge, its meters indicate the level of the channels currently-assigned to layer channels 1–24.

## Using the User Defined Keys

Up to 16 functions from a list of over 200 can be assigned to the USER DEFINED KEYS, and up to eight assignment setups can be stored in banks A to H. See page 283 for a list of initial bank assignments.

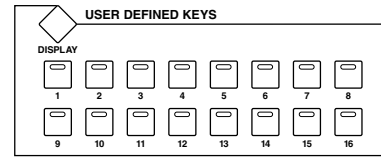

- 1 Use the USER DEFINED KEYS [DISPLAY] button to locate the User Defined Key Assign page.

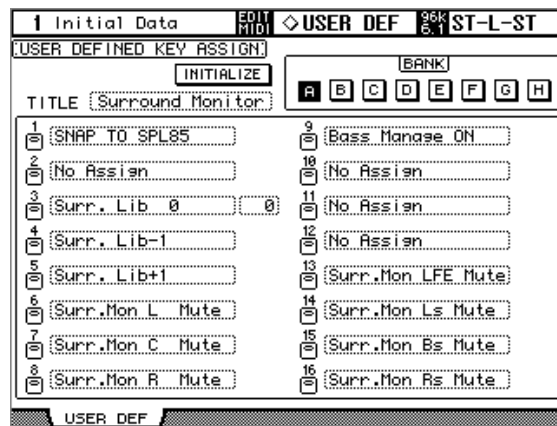

- 2 Use the cursor buttons to select the BANK buttons, A to H, and press [ENTER] to select a bank.

The TITLE parameter box displays the name of the selected bank. Select the TITLE parameter box, then press [ENTER]. The Title Edit window appears, enabling you to enter a name.

- 3 Use the cursor buttons to select from 1–16, then press [ENTER].

The following User Define Select window opens.

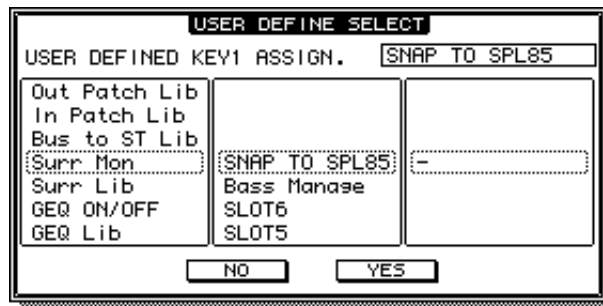

- 4 Move the cursor to the left column, then rotate the Parameter wheel or press the [INC]/[DEC] buttons to select the function you wish to assign.
- 5 Select options in the center and right columns in the same way.

The items displayed in the center and right columns vary depending on the function assigned in Step 4.

- 6 Use the cursor buttons to select YES, then press [ENTER].

When the window closes, the specified function is assigned to the selected User Defined button.

When you select a function that recalls a specific Scene or library memory, you need to specify the number of the memory that you want recalled when the USER DEFINED KEY is pressed. To do this, in the left-hand box, select the number parameter next to the Assign button, and use the Parameter wheel or INC/DEC buttons to specify the number.

You can initialize the assignments of the currently selected bank by selecting the INITIALIZE button, and pressing [ENTER].

User Defined Keys banks can be stored to an external MIDI device, such as a MIDI data filer, by using MIDI Bulk Dump (see page 220), or stored to SmartMedia (see page 271).

## Saving DM2000 Data to SmartMedia

### Saving

DM2000 Data can be saved to SmartMedia as follows.

- 1 Use the DISPLAY ACCESS [DATA] button to locate the Save page.

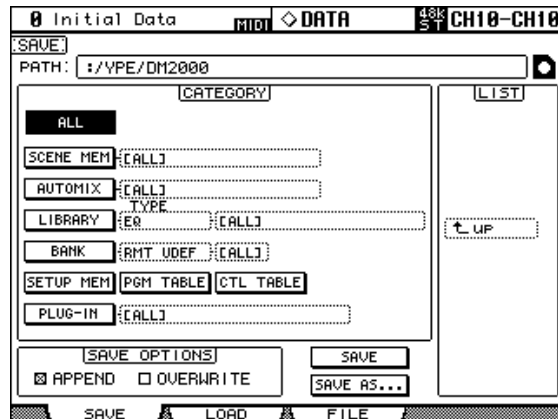

- 2 Insert your SmartMedia card into the CARD slot.

If the card doesn't have a "/YPE/DM2000" directory, a confirmation message appears and you should choose YES to make the directory.

The LIST box displays files and directories alphabetically. Only files of the currently selected CATEGORY are displayed. All files are displayed when the CATEGORY is set to ALL. Use the cursor buttons to select the LIST box, and then use the Parameter wheel or INC/DEC buttons to select files and directories. Directories have a small "D" next to their name. You can open the currently selected directory by pressing [ENTER]. To move up the directory structure, select "up," and then press [ENTER]. You cannot move up beyond the "/YPE/DM2000" directory.

The PATH box indicates the path of the currently selected file. The SmartMedia icon to the right of the PATH box indicates whether or not a SmartMedia card is inserted: "O" when a card is inserted, "X" when no card is inserted.

- 3 To save data, use the CATEGORY parameters to select the type of data you want to save, use the LIST box to select where you want to save the data, select the SAVE button, and then press [ENTER].

When the Title Edit window appears, enter a filename, and press OK when you've finished. See "Title Edit Window" on page 54 for more information.

You can save data with a different name by using the SAVE AS button.

When saving individual items, such as Scenes or library memories, you can use the SAVE OPTIONS APPEND and OVERWRITE to append individual memories to existing files or to overwrite them. The SAVE OPTIONS are unavailable and the existing files are overwritten when ALL, or SCENE MEM ALL, AUTOMIX ALL, LIBRARY ALL, BANK ALL, or PLUG IN ALL is selected.

The CATEGORY parameters can be set as follows:

**ALL:** Saves all data.

**SCENE MEM:** Saves Scenes. You can save ALL Scenes, individual Scenes, or the Edit Buffer (i.e., the current Scene).

**AUTOMIX:** Saves Automixes. You can save ALL Automixes, individual Automixes, or the current Automix.

**LIBRARY:** Saves the following libraries: EQ, Gate, Comp, Channel, Effects, GEQ, Bus to Stereo, Input Patch, Output Patch, Surround Monitor. For each library you can select ALL user memories, individual user memories, and for the Bus to Stereo, Input Patch, Output Patch, Surround Monitor libraries you can also select the current settings.

**BANK:** Saves the User Defined Remote banks (RMT UDEF), User Defined Plug-Ins banks (PLUG UDEF), USER DEFINED KEYS banks (KEYS UDEF), or the USER ASSIGNABLE LAYER banks (USR LAYER). For each item you can select ALL or individual banks.

**SETUP MEM:** Saves the DM2000 setup data (i.e., system settings).

**PGM TABLE:** Saves the Scene to MIDI Program Change table. See “Assigning Scenes to Program Changes” on page 218.

**CTL TABLE:** Saves the Parameter to MIDI Control Change table. See “Assigning Parameters to Control Changes” on page 219.

**PLUG-IN:** Saves the settings of the effects processing cards installed in the Slots. You can save ALL Slots or individual Slots.

*Note: You cannot save data that exceeds the remaining space on a SmartMedia card. Even if you try to overwrite the existing data, you will require a space equivalent to the size of the data you are trying to save.*

## Loading

DM2000 data can be loaded from SmartMedia as follows.

- 1 Use the DISPLAY ACCESS [DATA] button to locate the Load page.

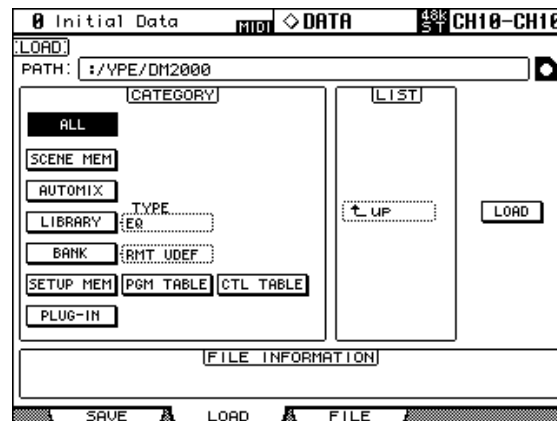

- 2 Insert your SmartMedia card into the CARD slot.
- 3 To load data, use the buttons in the CATEGORY box to select the type of file you want to load, select a file in the LIST box, select the LOAD button, and then press [ENTER].

The FILE INFORMATION box displays the filename and the date when the currently selected file was last stored. See “Saving” on page 271 for information on the PATH and LIST boxes and the SmartMedia icon.



## Managing Files & SmartMedia

Files stored on SmartMedia can be renamed and deleted as follows.

- 1 Use the **DISPLAY ACCESS [DATA]** button to locate the File page.

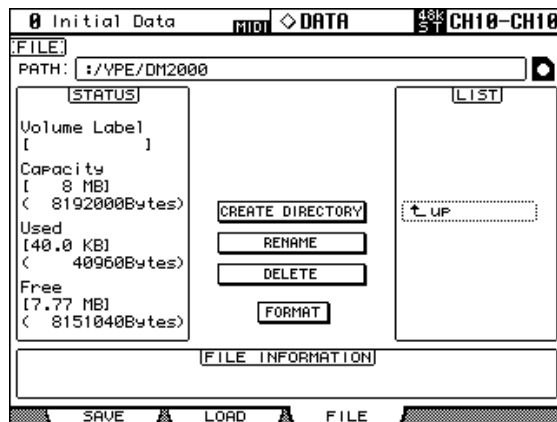

- 2 Insert your SmartMedia card into the **CARD** slot.

If the card doesn't have a "/YPE/DM2000" directory, a confirmation message appears and you should choose YES to make the directory.

The **FILE INFORMATION** box displays the filename and the date when the currently selected file was last stored. See "Saving" on page 271 for information on the **PATH** and **LIST** boxes and the SmartMedia icon.

The **STATUS** box displays information about the currently inserted SmartMedia card, including, its Volume Label, total Capacity, amount of Used space, and amount of Free space.

- 3 To create a new directory, use the **LIST** box to select the directory in which you want to create the new directory, select the **CREATE DIRECTORY** button, and then press **[ENTER]**.

When the Title Edit window appears, enter a name for the new directory, and press OK when you've finished. See "Title Edit Window" on page 54 for more information.

- 4 To rename a file or directory, use the **LIST** box to select that file or directory, select the **RENAME** button, and then press **[ENTER]**.

When the Title Edit window appears, edit the name, and press OK when you've finished. See "Title Edit Window" on page 54 for more information.

- 5 To delete a file or directory, use the **LIST** box to select that file or directory, select the **DELETE** button, and then press **[ENTER]**.

- 6 To format a SmartMedia card, select the **FORMAT** button, and press **[ENTER]**.

When the Title Edit window appears, enter a volume label for the card, and press OK when you've finished. See "Title Edit Window" on page 54 for more information. The directory "/YPE/DM2000" is created automatically.

*Note: During formatting, the DM2000 system is busy. You should format a card while the DM2000 is not performing other operations. During the Automix operation or while you are using included Card Filer application, you cannot access the SmartMedia card from the Save, Load, and File pages.*

You can use the Studio Manager to save DM1000, 02R96, or 01V96 data to, and load data from, a SmartMedia card. When saving data to a SmartMedia card, use a card formatted using the format option on the File page of the DM2000, and save data to a directory called "/YPE/DM2000" or lower hierarchical directory.

The following file types are compatible between these different consoles:

- Scene Memory (file extension: .D2M)
- Equalizer Library (file extension: .D2Q)
- Gate Library (file extension: .D2G)
- Compressor Library (file extension: .D2Y)
- Effect Library (file extension: .D2F)
- Channel Library (file extension: .D2H)
- Automix Memory (file extension: .D2A)

You can also load ALL data for each console (file extension: .02X, .D1X, .01X) by changing the extension to .D2X. In this case, you can load the following compatible data:

Scene Memory, Equalizer Library, Gate Library, Compressor Library, Effect Library, Channel Library, Bus To Stereo Library, Surround Monitor Library, Automix Memory, User Defined Remote Layer, User Defined Plug-In, Program Change Table, Plug-In Card Memory, User Assignable Layer.

*Note: Some of the data listed above may use default settings or may not be updated due to differences in parameters or numbers of channels.*

## Setting Preferences

You can customize the operation of the DM2000 by using the preferences pages.

### Preferences 1

- 1 Use the DISPLAY ACCESS [SETUP] button to locate the Preferences 1 page.

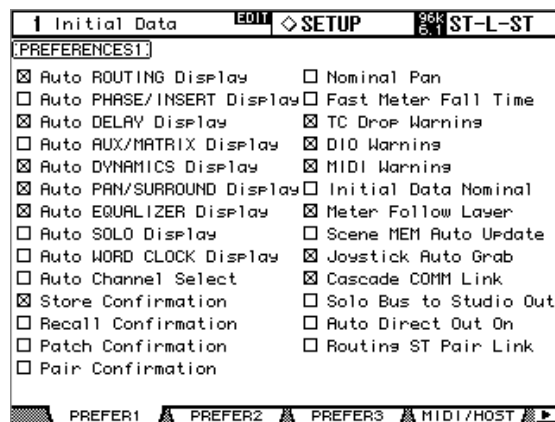

- 2 Use the cursor buttons or Parameter wheel to select the preferences, and use the INC/DEC buttons or [ENTER] button to set them.

**Auto ROUTING Display:** When this preference is on, the Routing pages appear automatically when a button in the SELECTED CHANNEL ROUTING section is pressed (see page 93).

**Auto PHASE/INSERT Display:** When this preference is on, the Phase pages appear automatically when the Phase [∅] button in the SELECTED CHANNEL PHASE/INSERT section is switched from off to on (see page 84), and the Insert page appears automatically when the SELECTED CHANNEL PHASE/INSERT [INSERT ON] button is pressed (see page 135).

**Auto DELAY Display:** When this option is on, the Delay pages appear automatically when a control in the SELECTED CHANNEL DELAY section is operated (see page 141).

**Auto AUX/MATRIX Display:** When this preference is on, the Aux View pages appear automatically when a SELECTED CHANNEL AUX/MATRIX SEND control is operated while an Input Channel is selected (see page 114), and the Matrix View page appears automatically when a SELECTED CHANNEL AUX/MATRIX SEND control is operated while a Bus Out, Aux Send, or the Stereo Out is selected (see page 124).

**Auto DYNAMICS Display:** When this preference is on, the Gate Edit page appears automatically when a gate control in the SELECTED CHANNEL DYNAMICS section is operated (see page 85), and the Comp Edit page appears automatically when a Compressor control in the SELECTED CHANNEL DYNAMICS section is operated (see page 137).

**Auto PAN/SURROUND Display:** When this preference is on and Input Channels have been selected, the Pan pages appears automatically when a control in the SELECTED CHANNEL PAN/SURROUND section is operated (see page 96). Similarly, when a Surround Pan mode other than Stereo is selected, the Input Channel Surround Edit page appears automatically when the Joystick is operated (see page 100). Also, when Stereo or Matrix is selected, the Fader View page appears automatically when the Pan controls are operated.

**Auto EQUALIZER Display:** When this preference is on, the EQ Edit page appears automatically when a control in the SELECTED CHANNEL EQUALIZER section is operated (see page 134).

**Auto SOLO Display:** When this option is on, the Solo Setup page appears automatically when an channel is soloed (see page 143).

**Auto WORD CLOCK Display:** When this preference is on, the Word Clock Select page appears automatically if the currently selected external wordclock source fails (see page 67).

**Auto Channel Select:** When this preference is on, channels can be selected by moving the corresponding fader or Encoder, or by turning on the corresponding [AUTO], [SOLO], or [ON] button.

**Store Confirmation:** When this preference is on, the Title Edit window appears when you store a Scene (page 187) or library memory (page 165). However, when you store an Automix library memory, the Title Edit window appears regardless of whether this preference is set to on or off.

**Recall Confirmation:** When this preference is on, a confirmation message appears when you recall a Scene (page 187) or library memory (page 165).

**Patch Confirmation:** When this preference is on, a confirmation message appears when you edit the Input and Output Patches (see page 77).

**Pair Confirmation:** When this preference is on, a confirmation message appears when you pair channels using the [SEL] buttons.

**Nominal Pan:** When this preference is on, left/odd and right/even signals will be at nominal level when Input Channel, Bus to Stereo, Bus to Matrix, or Aux to Matrix signals are panned hard left or hard right, and at  $-3$  dB when panned center. When this preference is off, signals panned hard left or hard right will be at 3 dB, and at nominal level when panned center. In Surround mode, this preference setting is used for the signal of any Surround Pan channel that is fully panned.

**Fast Meter Fall Time:** When this preference is on, the level meters fall quicker.

**TC Drop Warning:** When this preference is on, a warning message appears if a dropout is detected in the incoming timecode.

**DIO Warning:** When this preference is on, a warning message appears if any errors are detected in digital audio signals received by the Slot Inputs or 2TR Digital Inputs.

**MIDI Warning:** When this preference is on, a warning message appears if any errors are detected in the incoming MIDI messages.

**Initial Data Nominal:** When this preference is on, Input Channel faders are set to nominal when Scene #0 is recalled.

**Meter Follow Layer:** When this preference is on, the optional MB2000 Peak Meter Bridge automatically follows the Layer selection on the DM2000.

**Scene MEM Auto Update:** When this preference is on, the Shadow Scene memories can be used (see page 186).

**Joystick Auto Grab:** When this preference is on, the Joystick automatically kicks in as the surround pan control when it's moved to the current surround pan position (see page 100).

**Cascade COMM Link:** When this preference is on, various functions are linked between cascaded DM2000s (see page 74). When this preference is off, only digital audio signals are distributed among the cascaded DM2000s.

**Solo Bus to Studio Out:** When this preference is on and all STUDIO buttons ([CONTROL ROOM], [STEREO], [AUX 11], [AUX 12]) in the MONITOR section are turned off, soloed Input Channel signals are output via the STUDIO MONITOR OUT.

**Auto Direct Out On:** When this preference is on and you change the channel Direct Out destination from “–” to any other output, the channel Direct Out is automatically enabled. If you change the channel Direct Out destination from an output to “–,” the channel Direct Out is automatically disabled.

**Routing ST Pair Link:** When this preference is on, routing from paired channels to the Stereo Bus is linked.

## Preferences 2

- 1 Use the DISPLAY ACCESS [SETUP] button to locate the Preferences 2 page.

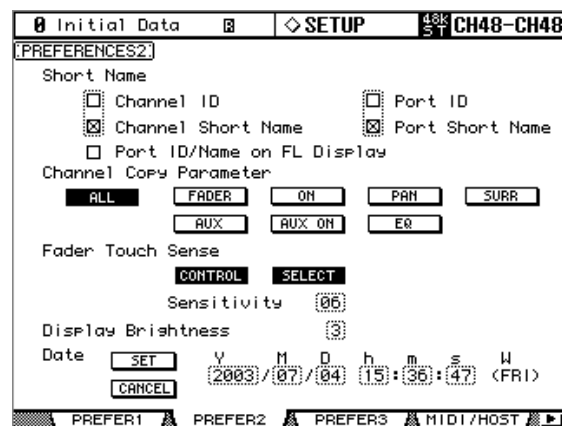

- 2 Use the cursor buttons to select the preferences, and use the Parameter wheel, INC/DEC buttons, or [ENTER] button to set them.

**Channel ID:** The Channel Strip Displays indicate the corresponding Channel ID.

**Channel Short Name:** The Channel Strip Displays indicate the corresponding Channel Short Name.

**Port ID/Name on FL Display:** The Channel Strip Displays indicate the Port ID or Port Name. You can choose an identifier by using the Port ID or Port Short Name option.

**Port ID:** The Channel Strip Displays indicate the Port ID.

**Port Short Name:** The Channel Strip Displays indicate the Port Short Name.

**Channel Copy Parameter:** These buttons allow you to choose which channel parameters are copied by the Channel Copy function: ALL parameters, or any combination of FADER, ON, PAN, SURR, AUX, AUX ON, and EQ. See “Copying Channel Settings” on page 155.

**Fader Touch Sense:** These parameters control the Touch Sense function. If the CONTROL button is turned on and the touch sensors are not triggered, fader operation is ignored. During Automix recording, you can “cut-in” by touching a fader. When this button

is off, the DM2000 always recognizes fader movements. If the SELECT button is on, you can select channels using the Touch Sense function.

The Sensitivity parameter adjusts touch sensitivity. If you're having trouble selecting channels because the fader knobs are insufficiently sensitive, try increasing this value. If they are too sensitive, try reducing it. It's important that the DM2000 is grounded properly for Touch Select to work correctly. See "Grounding screw" on page 50 for more information.

**Display Brightness:** This preference is used to set the brightness of the fluorescent and LED displays and indicators.

**Date:** These parameters are used to set the date and time that is applied to files when they stored to SmartMedia. Use the Parameter wheel or INC/DEC buttons to set the parameters, and then press the SET button, or press CANCEL to cancel.

## Preferences 3

- 1 Use the DISPLAY ACCESS [SETUP] button to locate the Preferences 3 page.

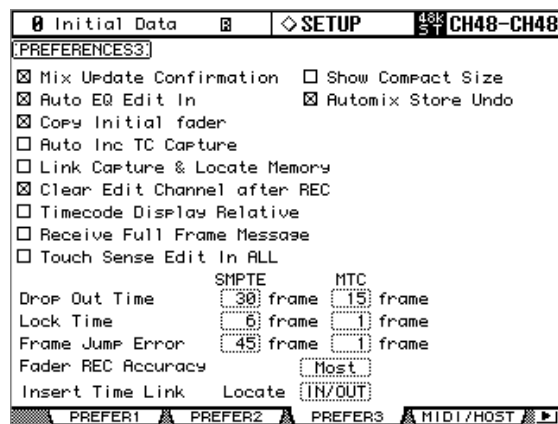

- 2 Use the cursor buttons or Parameter wheel to select the preferences, and use the INC/DEC buttons or [ENTER] button to set them.

**Mix Update Confirmation:** When this preference is on, a confirmation message asking if you want to update the current Automix with the latest edits appears when Automix recording is stopped.

**Auto EQ Edit In:** When this preference is on, EQ is automatically punched into Automix recording when an EQ control is adjusted.

**Copy Initial Fader:** When this preference is on, when Fader events are copied or moved on the Automix Event Copy page, the fader value at the specified IN point is copied to the specified TO point. This eliminates fader position matching problems when no fader event exists at the specified TO point.

**Auto Inc TC Capture:** When this preference is on, the Timecode Capture memory is incremented automatically each time a timecode address is captured on the Automix Event Edit page (see page 209).

**Link Capture & Locate Memory:** When this preference is on, the eight Capture memories on the Automix Event Edit page are linked to the eight Locate memories so that, for example, edits made to Capture memory #1 are reflected on Locate memory #1, and vice versa.

**Clear Edit Channel after REC:** When this preference is on, when using Auto Rec, channels are automatically unarmed (i.e., [AUTO] buttons are turned off) when Automix recording stops. When this preference is off, channels remain armed when recording stops.

**Timecode Display Relative:** When this preference is on, the indicated timecode is off-set as specified by the OFFSET parameter on the Automix Main page.

**Receive Full Frame Message:** When this preference is on, MTC full frame messages are recognized and Automix follows them.

**Touch Sense Edit In All:** When this preference is on, using the faders' Touch Sense function enables you to punch in and out all parameters for which the corresponding OVERWRITE buttons are turned on. When this preference is off, you can punch in and out only these faders selected in Fader mode.

**Show Compact Size:** Automix data, except that in the Undo buffer, is compressed while recording. When this preference is on, the compressed size of the Automix is displayed on the Automix Memory pages. When this preference is off, the uncompressed size is displayed.

**Automix Store Undo:** When this preference is on, Automix Store operations can be undone by using the Undo function.

**Drop Out Time:** This parameter sets an interval (in frames) between the interruption of incoming timecode and the stoppage of Automix recording or playback.

**Lock Time:** This parameter sets the interval (in frames) allowed until the Automix locks to incoming timecode messages. If the sync operation is unstable, set this value higher.

**Frame Jump Error:** This parameter sets the time interval (in frames) required by the DM2000 to recognize an error after incoming timecode messages jump. If the actual interval is shorter than the value specified by this parameter, the DM2000 continues the sync operation. If the frame jump causes the recording or playback to stop during the MTC and SMPT sync operation, set the parameter value higher than the number of frames indicated in the error message.

If you set the parameter to a higher value, adjust the Drop Out Time parameter value, if necessary.

**Fader REC Accuracy:** This parameter sets the accuracy of recording faders over time to "Little," "Some," "More," or "Most." If you set the parameter to lower values, you will save Automix memory space.

**Insert Time Link:** This parameter enables you to select the locate memory used for the IN and OUT parameters in the Insert operation.

## Using the Oscillator

The DM2000 features an oscillator that can be used for calibration or diagnostic purposes.

- 1 Use the **DISPLAY ACCESS [UTILITY]** button to locate the Oscillator page.

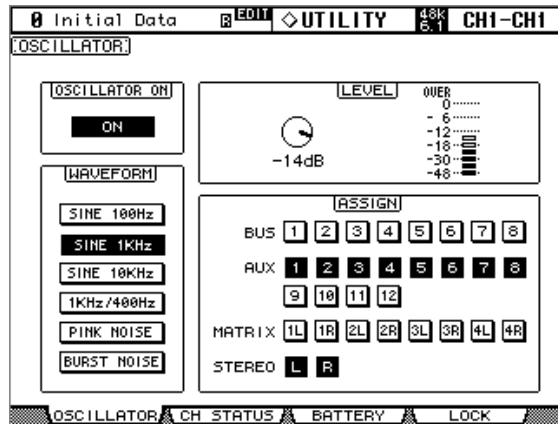

- 2 Use the cursor buttons to select the parameters, and use the Parameter wheel, INC/DEC button, or [ENTER] button to set them.

**OSCILLATOR ON:** This turns the Oscillator on or off. While the LEVEL parameter is selected, the [ENTER] button can be used to turn on and off the Oscillator.

*Note: To prevent any sudden tone burst surprises in your monitors or headphones, you may want to set the LEVEL parameter to minimum before turning on the oscillator.*

**LEVEL:** This sets the Oscillator output level, which is displayed by the adjacent meter. This parameter can be set by using the Parameter wheel regardless of which parameter is currently selected.

**WAVEFORM:** These buttons are used to select the waveforms: SINE 100Hz, SINE 1kHz, SINE 10kHz, 1kHz/400Hz, PINK NOISE, or BURST NOISE, which is 200 msec pink noise pulses at four second intervals. If you select 1 kHz/400 Hz, the Oscillator outputs a sine wave at different frequencies to L, R, and odd/even buses.

**ASSIGN:** These buttons are used to assign the Oscillator output to Bus Outs, Aux Sends, Matrix Sends, and the Stereo Out.

## Operation Lock

The DM2000 features the Operation Lock function, which avoids unintentional edits and uses a password to restrict access to panel operation.

- 1 Use the **DISPLAY ACCESS [UTILITY]** button to locate the Operation Lock page.

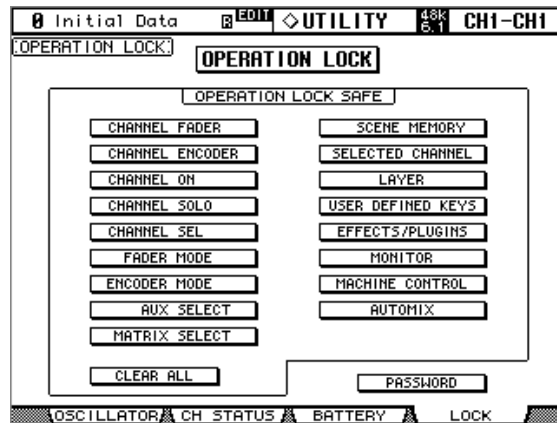

- 2 Use the cursor buttons to select the **PASSWORD** button, then press **[ENTER]**.



- 3 Use the **[SEL]** buttons to set the password.

Enter a four-letter password using the Channel 1–10 **[SEL]** buttons (Channel 10 **[SEL]** button enters “0”). (The factory default password is 1234.)

Enter the current password in the **PASSWORD** field, and a new password in the **NEW PASSWORD** field. Enter the new password again in the **REENTRY** field.

- 4 Use the cursor buttons to select the **OK** button, then press **[ENTER]** to update the password.

If you forget the password, you will be unable to cancel Operation Lock. Be sure to remember the password.



- 5 Use the buttons in the OPERATION LOCK SAFE section to select certain controls on the panel to exclude from Operation Lock.

Buttons	Controls excluded from Operation Lock
CHANNEL FADER	Channel faders (1–24, STEREO)
CHANNEL ENCODER	Channel Encoders (1–24)
CHANNEL ON	Channel [ON] buttons (1–24, STEREO)
CHANNEL SOLO	Channel [SOLO] buttons (1–24)
CHANNEL SEL	Channel [SEL] buttons (1–24, STEREO)
FADER MODE	All buttons in the FADER MODE section
ENCODER MODE	All buttons in the ENCODER MODE section
AUX SELECT	All buttons in the AUX SELECT section
MATRIX SELECT	All buttons in the MATRIX SELECT section
SCENE MEMORY	All buttons in the SCENE MEMORY section (excluding the [STORE] button)
SELECTED CHANNEL	All controls in the SELECTED CHANNEL section (excluding the [COPY] and [PASTE] buttons)
LAYER	All buttons in the LAYER section
USER DEFINED KEYS	All buttons in the USER DEFINED KEYS section
EFFECTS/PLUGINS	All buttons in the EFFECTS/PLUG-INS section (including the Parameter controls 1–4)
MONITOR	All controls in the MONITOR section
MACHINE CONTROL <sup>1</sup>	All buttons in the LOCATOR and TRACK ARMING sections, and all Transport buttons
AUTOMIX	All buttons in the AUTOMIX section and Channel [AUTO] buttons (1–24, STEREO)

1. The Parameter wheel is also excluded from Operation Lock when the [SHUTTLE] or [SCRUB] button is on.

- 6 Use the cursor buttons to select the OPERATION LOCK button, then press [ENTER].

The Password window appears.



- 7 Use the [SEL] buttons to enter the password you set in Step 4.

The Operation Lock function is activated.

To cancel Operation Lock, press [ENTER]. The Password window opens again. Enter the same password again, and Operation Lock is cancelled.

## Checking the Battery and the System Version

The condition of the internal memory-backup battery can be checked as follows.

- 1 Use the **DISPLAY ACCESS [UTILITY]** button to locate the **Battery Check** page.

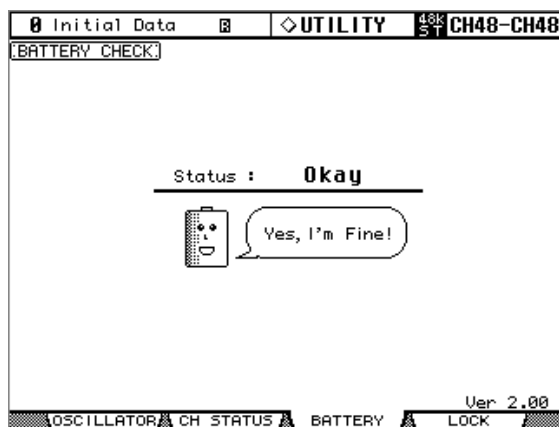

If the Status is “Okay,” the battery is okay. If the Status is “Getting Low,” ask your Yamaha dealer to replace the battery as soon as possible. Do not attempt to replace the battery yourself. Failure to replace a low battery may result in data loss.

**Ver x.xx:** This description identifies the system version number. Check the current system version number against this description before you update the firmware. Visit the following website to check the latest system version number:

<http://www.yamahaproaudio.com/>

## Initializing the DM2000

The DM2000 can be initialized as follows.

*Warning: This procedure will clear all user memories and reset all settings to their initial values. You may want to back up any important data beforehand via MIDI Bulk Dump (see page 220), or to SmartMedia (see page 271). If you want to reset just the mix settings, recall scene memory #0 instead (see page 186).*

- 1 **Turn off the DM2000.**
- 2 **While holding down the SCENE MEMORY [STORE] button, turn on the DM2000.**
- 3 **When the confirmation message appears, release the SCENE MEMORY [STORE] button, select [INITIALIZE] button, and press [ENTER].**

The following message is displayed while initialization is in progress: “Loading Factory Presets & Calibrating the Faders... Do Not Touch the Faders!”

**It’s important that you do not touch the faders while this message is displayed, as the faders may not be calibrated correctly.**

The display returns to normal when initialization is complete.

## Initializing the Password

Follow the steps below to initialize the password for the Operation Lock function.

- 1 **Turn off the power to the DM2000.**
- 2 **Hold down the SCENE MEMORY [STORE] button, and turn on the power to the DM2000.**
- 3 **When a confirmation message appears, release the SCENE MEMORY [STORE] button. Use the cursor buttons to select the PASSWORD button, then press [ENTER].**

The password is reset to “1234”.

# Appendix A: Parameter Lists

## USER DEFINED KEYS

#	Function	Display
0	No ASSIGN	No Assign
1	Scene MEM. Recall +1	Scene +1 Recall
2	Scene MEM. Recall -1	Scene -1 Recall
3	Scene MEM. Recall No. XX	Scene XX Recall
4	Effect-1 Lib. Recall +1	Fx1 Lib+1 Recall
5	Effect-1 Lib. Recall -1	Fx1 Lib-1 Recall
6	Effect-1 Lib. Recall No. XX	Fx1 LibXXX RCL.
7	Effect-2 Lib. Recall +1	Fx2 Lib+1 Recall
8	Effect-2 Lib. Recall -1	Fx2 Lib-1 Recall
9	Effect-2 Lib. Recall No.XX	Fx2 LibXXX RCL.
10	Effect-3 Lib. Recall +1	Fx3 Lib+1 Recall
11	Effect-3 Lib. Recall -1	Fx3 Lib-1 Recall
12	Effect-3 Lib. Recall No.XX	Fx3 LibXXX RCL.
13	Effect-4 Lib. Recall +1	Fx4 Lib+1 Recall
14	Effect-4 Lib. Recall -1	Fx4 Lib-1 Recall
15	Effect-4 Lib. Recall No.XX	Fx4 LibXXX RCL.
16	Effect-5 Lib. Recall +1	Fx5 Lib+1 Recall
17	Effect-5 Lib. Recall -1	Fx5 Lib-1 Recall
18	Effect-5 Lib. Recall No.XX	Fx5 LibXXX RCL.
19	Effect-6 Lib. Recall +1	Fx6 Lib+1 Recall
20	Effect-6 Lib. Recall -1	Fx6 Lib-1 Recall
21	Effect-6 Lib. Recall No.XX	Fx6 LibXXX RCL.
22	Effect-7 Lib. Recall +1	Fx7 Lib+1 Recall
23	Effect-7 Lib. Recall -1	Fx7 Lib-1 Recall
24	Effect-7 Lib. Recall No.XX	Fx7 LibXXX RCL.
25	Effect-8 Lib. Recall +1	Fx8 Lib+1 Recall
26	Effect-8 Lib. Recall -1	Fx8 Lib-1 Recall
27	Effect-8 Lib. Recall No.XX	Fx8 LibXXX RCL.
28	Effect-1 Bypass On/Off	Fx1 Bypass
29	Effect-2 Bypass On/Off	Fx2 Bypass
30	Effect-3 Bypass On/Off	Fx3 Bypass
31	Effect-4 Bypass On/Off	Fx4 Bypass
32	Effect-5 Bypass On/Off	Fx5 Bypass
33	Effect-6 Bypass On/Off	Fx6 Bypass
34	Effect-7 Bypass On/Off	Fx7 Bypass
35	Effect-8 Bypass On/Off	Fx8 Bypass
36	Channel Lib. Recall +1	CH Lib+1 Recall
37	Channel Lib. Recall -1	CH Lib-1 Recall
38	Channel Lib. Recall No. XX	CH LibXXX Recall
39	GATE Lib. Recall +1	Gate Lib+1 RCL.
40	GATE Lib. Recall -1	Gate Lib-1 RCL.
41	GATE Lib. Recall No. XX	Gate LibXXX RCL.
42	COMP Lib. Recall +1	Comp Lib+1 RCL.
43	COMP Lib. Recall -1	Comp Lib-1 RCL.
44	COMP Lib. Recall No. XX	Comp LibXXX RCL.
45	EQ Lib. Recall +1	EQ Lib+1 Recall
46	EQ Lib. Recall -1	EQ Lib-1 Recall
47	EQ Lib. Recall No. XX	EQ LibXXX Recall
48	GEQ1 Lib. Recall +1	GEQ1 Lib+1 RCL.
49	GEQ1 Lib. Recall -1	GEQ1 Lib-1 RCL.
50	GEQ1 Lib. Recall No. XX	GEQ1 LibXXX RCL.
51	GEQ2 Lib. Recall +1	GEQ2 Lib+1 RCL.
52	GEQ2 Lib. Recall -1	GEQ2 Lib-1 RCL.

#	Function	Display
53	GEQ2 Lib. Recall No. XX	GEQ2 LibXXX RCL.
54	GEQ3 Lib. Recall +1	GEQ3 Lib+1 RCL.
55	GEQ3 Lib. Recall -1	GEQ3 Lib-1 RCL.
56	GEQ3 Lib. Recall No. XX	GEQ3 LibXXX RCL.
57	GEQ4 Lib. Recall +1	GEQ4 Lib+1 RCL.
58	GEQ4 Lib. Recall -1	GEQ4 Lib-1 RCL.
59	GEQ4 Lib. Recall No. XX	GEQ4 LibXXX RCL.
60	GEQ5 Lib. Recall +1	GEQ5 Lib+1 RCL.
61	GEQ5 Lib. Recall -1	GEQ5 Lib-1 RCL.
62	GEQ5 Lib. Recall No. XX	GEQ5 LibXXX RCL.
63	GEQ6 Lib. Recall +1	GEQ6 Lib+1 RCL.
64	GEQ6 Lib. Recall -1	GEQ6 Lib-1 RCL.
65	GEQ6 Lib. Recall No. XX	GEQ6 LibXXX RCL.
66	GEQ-1 On/Off	GEQ1 ON/OFF
67	GEQ-2 On/Off	GEQ2 ON/OFF
68	GEQ-3 On/Off	GEQ3 ON/OFF
69	GEQ-4 On/Off	GEQ4 ON/OFF
70	GEQ-5 On/Off	GEQ5 ON/OFF
71	GEQ-6 On/Off	GEQ6 ON/OFF
72	SURR. MONI MUTE Mute L On/Off	Surr.Mon L Mute
73	SURR. MONI MUTE Mute R On/Off	Surr.Mon R Mute
74	SURR. MONI MUTE Mute Ls On/Off	Surr.Mon Ls Mute
75	SURR. MONI MUTE Mute Rs On/Off	Surr.Mon Rs Mute
76	SURR. MONI MUTE Mute C On/Off	Surr.Mon C Mute
77	SURR. MONI MUTE Mute LFE On/Off	Surr.Mon LFEMute
78	SURR.MONI ASSIGN X SLOT1 ON/OFF	Surr.ASGNX SL1 ON
79	SURR.MONI ASSIGN X SLOT2 ON/OFF	Surr.ASGNX SL2 ON
80	SURR.MONI ASSIGN X SLOT3 ON/OFF	Surr.ASGNX SL3 ON
81	SURR.MONI ASSIGN X SLOT4 ON/OFF	Surr.ASGNX SL4 ON
82	SURR.MONI ASSIGN X SLOTS ON/OFF	Surr.ASGNX SL5 ON
83	SURR.MONI ASSIGN X SLOT6 ON/OFF	Surr.ASGNX SL6 ON
84	SURR. MONI BASS MANAGE ON/OFF	Bass Manage ON
85	Input Fader Group Enable A	IN Fader Group A
86	Input Fader Group Enable B	IN Fader Group B
87	Input Fader Group Enable C	IN Fader Group C
88	Input Fader Group Enable D	IN Fader Group D
89	Input Fader Group Enable E	IN Fader Group E
90	Input Fader Group Enable F	IN Fader Group F
91	Input Fader Group Enable G	IN Fader Group G
92	Input Fader Group Enable H	IN Fader Group H
93	Input MUTE Group Enable I	IN Mute Group I
94	Input MUTE Group Enable J	IN Mute Group J
95	Input MUTE Group Enable K	IN Mute Group K
96	Input MUTE Group Enable L	IN Mute Group L
97	Input MUTE Group Enable M	IN Mute Group M
98	Input MUTE Group Enable N	IN Mute Group N
99	Input MUTE Group Enable O	IN Mute Group O
100	Input MUTE Group Enable P	IN Mute Group P
101	Output Fader Group Enable Q	OutFader Group Q
102	Output Fader Group Enable R	OutFader Group R
103	Output Fader Group Enable S	OutFader Group S
104	Output Fader Group Enable T	OutFader Group T
105	Output MUTE Group Enable U	Out Mute Group U

#	Function	Display
106	Output MUTE Group Enable V	Out Mute Group V
107	Output MUTE Group Enable W	Out Mute Group W
108	Output MUTE Group Enable X	Out Mute Group X
109	PEAK HOLD On/Off	Peak Hold
110	OSCILLATOR On/Off	OSC. ON/OFF
111	SOLO Enable	SOLO ENABLE
112	Input Patch Lib. Recall +1	IN Patch Lib+1
113	Input Patch Lib. Recall -1	IN Patch Lib-1
114	Input Patch Lib. Recall No. XX	IN Patch LibXX
115	Output Patch Lib. Recall +1	Out Patch Lib+1
116	Output Patch Lib. Recall -1	Out Patch Lib-1
117	Output Patch Lib. Recall No. XX	Out Patch LibXX
118	Channel Name ID/Short	CH Name ID/Short
119	Port Name ID/Short	PortNameID/Short
120	Automix REC	Automix REC
121	Automix PLAY	Automix PLAY
122	Automix STOP	Automix STOP
123	Automix ABORT	Automix ABORT
124	Automix AUTO REC	Automix AUTOREC
125	Automix ENABLE	Automix ENABLE
126	Automix RETURN	Automix RETURN
127	Automix TAKEOVER	Automix TAKEOVER
128	Automix RELATIVE	Automix RELATIVE
129	Automix TOUCH SENSE	Automix T.SENSE
130	Overwrite FADER	Overwrite FADER
131	Overwrite ON	Overwrite ON
132	Overwrite PAN	Overwrite PAN
133	Overwrite SURROUND	Overwrite SURR.
134	Overwrite EQ	Overwrite EQ
135	Overwrite AUX	Overwrite AUX
136	Overwrite AUX ON	Overwrite AUX ON
137	Track Arming 1 ON/OFF	Track Arming 1
138	Track Arming 2 ON/OFF	Track Arming 2
139	Track Arming 3 ON/OFF	Track Arming 3
140	Track Arming 4 ON/OFF	Track Arming 4
141	Track Arming 5 ON/OFF	Track Arming 5
142	Track Arming 6 ON/OFF	Track Arming 6
143	Track Arming 7 ON/OFF	Track Arming 7
144	Track Arming 8 ON/OFF	Track Arming 8
145	Track Arming 9 ON/OFF	Track Arming 9
146	Track Arming 10 ON/OFF	Track Arming 10
147	Track Arming 11 ON/OFF	Track Arming 11
148	Track Arming 12 ON/OFF	Track Arming 12
149	Track Arming 13 ON/OFF	Track Arming 13
150	Track Arming 14 ON/OFF	Track Arming 14
151	Track Arming 15 ON/OFF	Track Arming 15
152	Track Arming 16 ON/OFF	Track Arming 16
153	Track Arming 17 ON/OFF	Track Arming 17
154	Track Arming 18 ON/OFF	Track Arming 18
155	Track Arming 19 ON/OFF	Track Arming 19
156	Track Arming 20 ON/OFF	Track Arming 20
157	Track Arming 21 ON/OFF	Track Arming 21
158	Track Arming 22 ON/OFF	Track Arming 22
159	Track Arming 23 ON/OFF	Track Arming 23
160	Track Arming 24 ON/OFF	Track Arming 24
161	SURR Lib. Recall +1	Surr Lib+1 RCL
162	SURR Lib. Recall -1	Surr Lib-1 RCL
163	SURR Lib. Recall No.XX	Surr LibXX RCL
164	SURR. MONI MUTE Mute Bs On/Off	Surr.Mon Bs Mute

#	Function	Display
165	SURR. MONI SNAP TO 85dB SPL	SNAP TO SPL85
166	Bus to ST Lib. Recall +1	BUS To ST LIB+1
167	Bus to ST Lib. Recall -1	BUS To ST LIB-1
168	Bus to ST Lib. Recall No. XX	BUS To ST LIBXX
169	Input Fader Group Assign X	IN Fader Assign X
170	Input Mute Group Assign X	IN Mute Assign X
171	Input EQ Group Assign X	IN EQ Assign x
172	Input COMP Group Assign X	IN COMP Assign x
173	Output Fader Group Assign X	OutFader Assign X
174	Output Mute Group Assign X	Out Mute Assign X
175	Output EQ Group Assign X	Out EQ Assign x
176	Output COMP Group Assign X	Out COMP Assign x
177	Input Mute Group Master X	In Mute Master X
178	Output MUTE Group Master X	Out Mute Master X
179	Automix UPDATE TO END	Amx UPDATE TO END
180	AUX/SOLO LINK Mode On/Off	AUX/SOLO LINK
181	FADER/SOLO RELEASE Mode On/Off	FaderSoloRELEASE
182	Talkback Assign SLOT1	Talkback SLOT1-XX
183	Talkback Assign SLOT2	Talkback SLOT2-XX
184	Talkback Assign SLOT3	Talkback SLOT3-XX
185	Talkback Assign SLOT4	Talkback SLOT4-XX
186	Talkback Assign SLOTS5	Talkback SLOTS5-XX
187	Talkback Assign SLOT6	Talkback SLOT6-XX
188	Talkback Assign OMNI OUT	Talkback OMNI-XX
189	Talkback Studio Monitor Out On/Off	Talkback S.Moni
190	FL DISPLAY Channel/Port	FL DISP CH/Port
191	User Defined Keys BANK +1	UDEF KEYS BANK+1
192	User Defined Keys BANK -1	UDEF KEYS BANK-1
193	User Defined Keys BANK X	UDEF KEYS BANK X
194	Remote User defined BANK +1	RMT UDEF BANK+1
195	Remote User defined BANK -1	RMT UDEF BANK-1
196	Remote User defined BANK X	RMT UDEF BANK X
197	User Assignable Layer BANK +1	USER LAYER BANK+1
198	User Assignable Layer BANK -1	USER LAYER BANK-1
199	User Assignable Layer BANK x	USER LAYER BANK x
200	MIDI NOTE No.XX	MIDI NOTE XXX
201	MIDI Program change No.XX	MIDI PGM XXX
202	MIDI Control Change No.XX	MIDI CC XXX
203	Studio Manager Window Control Close	SM CTRL Close
204	Studio Manager Window Control Close All	SM CTRL Close All
205	Studio Manager Window Control Selected Channel	SM CTRL Sel Ch
206	Studio Manager Window Control Library	SM CTRL Library
207	Studio Manager Window Control Patch Editor	SM CTRL Patch
208	Studio Manager Window Control Surround Editor	SM CTRL Surround
209	Studio Manager Window Control Time Counter	SM CTRL TimeCount
210	Studio Manager Window Control Effect Editor	SM CTRL Effect
211	Studio Manager Window Control GEQ Editor	SM CTRL GEQ
212	Studio Manager Window Control Meter	SM CTRL Meter
213	Studio Manager Window Control Layer	SM CTRL Layer
214	Studio Manager Window Control Master	SM CTRL Master

## USER DEFINED KEYS Initial Assignments

No.	Bank A (Surround Monitor)	Bank B (Scene Recall)	Bank C (Group Enable)	Bank D (No Assign)	Bank E (Effect Library)	Bank F (Group Assign)	Bank G (Mute Master)	Bank H (Program Change)
1	SNAP TO SPL 85	Scene 1 Recall	IN Fader Group A	No Assign	Fx 1 Lib+1 Recall	IN Fader Assign A	IN Mute Master I	MIDI PGM 1
2	No Assign	Scene 2 Recall	IN Fader Group B	No Assign	Fx 2 Lib+1 Recall	IN Fader Assign B	IN Mute Master J	MIDI PGM 2
3	Surr Lib 0 Recall	Scene 3 Recall	IN Fader Group C	No Assign	Fx 3 Lib+1 Recall	IN Fader Assign C	IN Mute Master K	MIDI PGM 3
4	Surr Lib-1 Recall	Scene 4 Recall	IN Fader Group D	No Assign	Fx 4 Lib+1 Recall	IN Fader Assign D	IN Mute Master L	MIDI PGM 4
5	Surr Lib+1 Recall	Scene 5 Recall	IN Fader Group E	No Assign	Fx 5 Lib+1 Recall	IN Fader Assign E	IN Mute Master M	MIDI PGM 5
6	Surr Mon L Mute	Scene 6 Recall	IN Fader Group F	No Assign	Fx 6 Lib+1 Recall	IN Fader Assign F	IN Mute Master N	MIDI PGM 6
7	Surr Mon C Mute	Scene 7 Recall	IN Fader Group G	No Assign	Fx 7 Lib+1 Recall	IN Fader Assign G	IN Mute Master O	MIDI PGM 7
8	Surr Mon R Mute	Scene +1 Recall	IN Fader Group H	No Assign	Fx 8 Lib+1 Recall	IN Fader Assign H	IN Mute Master P	MIDI PGM 8
9	Bass Manage ON	Scene 8 Recall	IN Mute Group I	No Assign	Fx 1 Lib-1 Recall	IN Mute Assign I	OUT Mute Master U	MIDI PGM 9
10	No Assign	Scene 9 Recall	IN Mute Group J	No Assign	Fx 2 Lib-1 Recall	IN Mute Assign J	OUT Mute Master V	MIDI PGM 10
11	No Assign	Scene 10 Recall	IN Mute Group K	No Assign	Fx 3 Lib-1 Recall	IN Mute Assign K	OUT Mute Master W	MIDI PGM 11
12	No Assign	Scene 11 Recall	IN Mute Group L	No Assign	Fx 4 Lib-1 Recall	IN Mute Assign L	OUT Mute Master X	MIDI PGM 12
13	Surr.Mon LFEMute	Scene 12 Recall	IN Mute Group M	No Assign	Fx 5 Lib-1 Recall	IN Mute Assign M	No Assign	MIDI PGM 13
14	Surr.Mon Ls Mute	Scene 13 Recall	IN Mute Group N	No Assign	Fx 6 Lib-1 Recall	IN Mute Assign N	No Assign	MIDI PGM 14
15	Surr.Mon Bs Mute	Scene 14 Recall	IN Mute Group O	No Assign	Fx 7 Lib-1 Recall	IN Mute Assign O	No Assign	MIDI PGM 15
16	Surr.Mon Rs Mute	Scene -1 Recall	IN Mute Group P	No Assign	Fx 8 Lib-1 Recall	IN Mute Assign P	No Assign	MIDI PGM 16

## Input Patch Parameters

input Channel Inputs		Input Channel insert Ins		Internal Effects Processor Inputs	
Port ID	Description	Port ID	Description	Port ID	Description
NONE	NONE	NONE	NONE	NONE	NONE
AD1	AD IN 1	AD1	AD IN 1	AUX1	AUX1
AD2	AD IN 2	AD2	AD IN 2	AUX2	AUX2
AD3	AD IN 3	AD3	AD IN 3	AUX3	AUX3
AD4	AD IN 4	AD4	AD IN 4	AUX4	AUX4
AD5	AD IN 5	AD5	AD IN 5	AUX5	AUX5
AD6	AD IN 6	AD6	AD IN 6	AUX6	AUX6
AD7	AD IN 7	AD7	AD IN 7	AUX7	AUX7
AD8	AD IN 8	AD8	AD IN 8	AUX8	AUX8
AD9	AD IN 9	AD9	AD IN 9	AUX9	AUX9
AD10	AD IN 10	AD10	AD IN 10	AUX10	AUX10
AD11	AD IN 11	AD11	AD IN 11	AUX11	AUX11
AD12	AD IN 12	AD12	AD IN 12	AUX12	AUX12
AD13	AD IN 13	AD13	AD IN 13	INSCH1	InsertOut-CH1
AD14	AD IN 14	AD14	AD IN 14	INSCH2	InsertOut-CH2
AD15	AD IN 15	AD15	AD IN 15	INSCH3	InsertOut-CH3
AD16	AD IN 16	AD16	AD IN 16	INSCH4	InsertOut-CH4
AD17	AD IN 17	AD17	AD IN 17	INSCH5	InsertOut-CH5
AD18	AD IN 18	AD18	AD IN 18	INSCH6	InsertOut-CH6
AD19	AD IN 19	AD19	AD IN 19	INSCH7	InsertOut-CH7
AD20	AD IN 20	AD20	AD IN 20	INSCH8	InsertOut-CH8
AD21	AD IN 21	AD21	AD IN 21	INSCH9	InsertOut-CH9
AD22	AD IN 22	AD22	AD IN 22	INSCH10	InsertOut-CH10
AD23	AD IN 23	AD23	AD IN 23	INSCH11	InsertOut-CH11
AD24	AD IN 24	AD24	AD IN 24	INSCH12	InsertOut-CH12
S1-1	Slot1 CH1 IN	S1-1	Slot1 CH1 IN	INSCH13	InsertOut-CH13
S1-2	Slot1 CH2 IN	S1-2	Slot1 CH2 IN	INSCH14	InsertOut-CH14
S1-3	Slot1 CH3 IN	S1-3	Slot1 CH3 IN	INSCH15	InsertOut-CH15
S1-4	Slot1 CH4 IN	S1-4	Slot1 CH4 IN	INSCH16	InsertOut-CH16
S1-5	Slot1 CH5 IN	S1-5	Slot1 CH5 IN	INSCH17	InsertOut-CH17
S1-6	Slot1 CH6 IN	S1-6	Slot1 CH6 IN	INSCH18	InsertOut-CH18
S1-7	Slot1 CH7 IN	S1-7	Slot1 CH7 IN	INSCH19	InsertOut-CH19
S1-8	Slot1 CH8 IN	S1-8	Slot1 CH8 IN	INSCH20	InsertOut-CH20
S1-9	Slot1 CH9 IN	S1-9	Slot1 CH9 IN	INSCH21	InsertOut-CH21
S1-10	Slot1 CH10 IN	S1-10	Slot1 CH10 IN	INSCH22	InsertOut-CH22
S1-11	Slot1 CH11 IN	S1-11	Slot1 CH11 IN	INSCH23	InsertOut-CH23
S1-12	Slot1 CH12 IN	S1-12	Slot1 CH12 IN	INSCH24	InsertOut-CH24
S1-13	Slot1 CH13 IN	S1-13	Slot1 CH13 IN	INSCH25	InsertOut-CH25
S1-14	Slot1 CH14 IN	S1-14	Slot1 CH14 IN	INSCH26	InsertOut-CH26
S1-15	Slot1 CH15 IN	S1-15	Slot1 CH15 IN	INSCH27	InsertOut-CH27
S1-16	Slot1 CH16 IN	S1-16	Slot1 CH16 IN	INSCH28	InsertOut-CH28
S2-1	Slot2 CH1 IN	S2-1	Slot2 CH1 IN	INSCH29	InsertOut-CH29
S2-2	Slot2 CH2 IN	S2-2	Slot2 CH2 IN	INSCH30	InsertOut-CH30
S2-3	Slot2 CH3 IN	S2-3	Slot2 CH3 IN	INSCH31	InsertOut-CH31
S2-4	Slot2 CH4 IN	S2-4	Slot2 CH4 IN	INSCH32	InsertOut-CH32
S2-5	Slot2 CH5 IN	S2-5	Slot2 CH5 IN	INSCH33	InsertOut-CH33
S2-6	Slot2 CH6 IN	S2-6	Slot2 CH6 IN	INSCH34	InsertOut-CH34
S2-7	Slot2 CH7 IN	S2-7	Slot2 CH7 IN	INSCH35	InsertOut-CH35
S2-8	Slot2 CH8 IN	S2-8	Slot2 CH8 IN	INSCH36	InsertOut-CH36
S2-9	Slot2 CH9 IN	S2-9	Slot2 CH9 IN	INSCH37	InsertOut-CH37
S2-10	Slot2 CH10 IN	S2-10	Slot2 CH10 IN	INSCH38	InsertOut-CH38
S2-11	Slot2 CH11 IN	S2-11	Slot2 CH11 IN	INSCH39	InsertOut-CH39

input Channel Inputs		Input Channel insert Ins		Internal Effects Processor Inputs	
Port ID	Description	Port ID	Description	Port ID	Description
S2-12	Slot2 CH12 IN	S2-12	Slot2 CH12 IN	INSCH40	InsertOut-CH40
S2-13	Slot2 CH13 IN	S2-13	Slot2 CH13 IN	INSCH41	InsertOut-CH41
S2-14	Slot2 CH14 IN	S2-14	Slot2 CH14 IN	INSCH42	InsertOut-CH42
S2-15	Slot2 CH15 IN	S2-15	Slot2 CH15 IN	INSCH43	InsertOut-CH43
S2-16	Slot2 CH16 IN	S2-16	Slot2 CH16 IN	INSCH44	InsertOut-CH44
S3-1	Slot3 CH1 IN	S3-1	Slot3 CH1 IN	INSCH45	InsertOut-CH45
S3-2	Slot3 CH2 IN	S3-2	Slot3 CH2 IN	INSCH46	InsertOut-CH46
S3-3	Slot3 CH3 IN	S3-3	Slot3 CH3 IN	INSCH47	InsertOut-CH47
S3-4	Slot3 CH4 IN	S3-4	Slot3 CH4 IN	INSCH48	InsertOut-CH48
S3-5	Slot3 CH5 IN	S3-5	Slot3 CH5 IN	INSCH49	InsertOut-CH49
S3-6	Slot3 CH6 IN	S3-6	Slot3 CH6 IN	INSCH50	InsertOut-CH50
S3-7	Slot3 CH7 IN	S3-7	Slot3 CH7 IN	INSCH51	InsertOut-CH51
S3-8	Slot3 CH8 IN	S3-8	Slot3 CH8 IN	INSCH52	InsertOut-CH52
S3-9	Slot3 CH9 IN	S3-9	Slot3 CH9 IN	INSCH53	InsertOut-CH53
S3-10	Slot3 CH10 IN	S3-10	Slot3 CH10 IN	INSCH54	InsertOut-CH54
S3-11	Slot3 CH11 IN	S3-11	Slot3 CH11 IN	INSCH55	InsertOut-CH55
S3-12	Slot3 CH12 IN	S3-12	Slot3 CH12 IN	INSCH56	InsertOut-CH56
S3-13	Slot3 CH13 IN	S3-13	Slot3 CH13 IN	INSCH57	InsertOut-CH57
S3-14	Slot3 CH14 IN	S3-14	Slot3 CH14 IN	INSCH58	InsertOut-CH58
S3-15	Slot3 CH15 IN	S3-15	Slot3 CH15 IN	INSCH59	InsertOut-CH59
S3-16	Slot3 CH16 IN	S3-16	Slot3 CH16 IN	INSCH60	InsertOut-CH60
S4-1	Slot4 CH1 IN	S4-1	Slot4 CH1 IN	INSCH61	InsertOut-CH61
S4-2	Slot4 CH2 IN	S4-2	Slot4 CH2 IN	INSCH62	InsertOut-CH62
S4-3	Slot4 CH3 IN	S4-3	Slot4 CH3 IN	INSCH63	InsertOut-CH63
S4-4	Slot4 CH4 IN	S4-4	Slot4 CH4 IN	INSCH64	InsertOut-CH64
S4-5	Slot4 CH5 IN	S4-5	Slot4 CH5 IN	INSCH65	InsertOut-CH65
S4-6	Slot4 CH6 IN	S4-6	Slot4 CH6 IN	INSCH66	InsertOut-CH66
S4-7	Slot4 CH7 IN	S4-7	Slot4 CH7 IN	INSCH67	InsertOut-CH67
S4-8	Slot4 CH8 IN	S4-8	Slot4 CH8 IN	INSCH68	InsertOut-CH68
S4-9	Slot4 CH9 IN	S4-9	Slot4 CH9 IN	INSCH69	InsertOut-CH69
S4-10	Slot4 CH10 IN	S4-10	Slot4 CH10 IN	INSCH70	InsertOut-CH70
S4-11	Slot4 CH11 IN	S4-11	Slot4 CH11 IN	INSCH71	InsertOut-CH71
S4-12	Slot4 CH12 IN	S4-12	Slot4 CH12 IN	INSCH72	InsertOut-CH72
S4-13	Slot4 CH13 IN	S4-13	Slot4 CH13 IN	INSCH73	InsertOut-CH73
S4-14	Slot4 CH14 IN	S4-14	Slot4 CH14 IN	INSCH74	InsertOut-CH74
S4-15	Slot4 CH15 IN	S4-15	Slot4 CH15 IN	INSCH75	InsertOut-CH75
S4-16	Slot4 CH16 IN	S4-16	Slot4 CH16 IN	INSCH76	InsertOut-CH76
S5-1	Slot5 CH1 IN	S5-1	Slot5 CH1 IN	INSCH77	InsertOut-CH77
S5-2	Slot5 CH2 IN	S5-2	Slot5 CH2 IN	INSCH78	InsertOut-CH78
S5-3	Slot5 CH3 IN	S5-3	Slot5 CH3 IN	INSCH79	InsertOut-CH79
S5-4	Slot5 CH4 IN	S5-4	Slot5 CH4 IN	INSCH80	InsertOut-CH80
S5-5	Slot5 CH5 IN	S5-5	Slot5 CH5 IN	INSCH81	InsertOut-CH81
S5-6	Slot5 CH6 IN	S5-6	Slot5 CH6 IN	INSCH82	InsertOut-CH82
S5-7	Slot5 CH7 IN	S5-7	Slot5 CH7 IN	INSCH83	InsertOut-CH83
S5-8	Slot5 CH8 IN	S5-8	Slot5 CH8 IN	INSCH84	InsertOut-CH84
S5-9	Slot5 CH9 IN	S5-9	Slot5 CH9 IN	INSCH85	InsertOut-CH85
S5-10	Slot5 CH10 IN	S5-10	Slot5 CH10 IN	INSCH86	InsertOut-CH86
S5-11	Slot5 CH11 IN	S5-11	Slot5 CH11 IN	INSCH87	InsertOut-CH87
S5-12	Slot5 CH12 IN	S5-12	Slot5 CH12 IN	INSCH88	InsertOut-CH88
S5-13	Slot5 CH13 IN	S5-13	Slot5 CH13 IN	INSCH89	InsertOut-CH89
S5-14	Slot5 CH14 IN	S5-14	Slot5 CH14 IN	INSCH90	InsertOut-CH90
S5-15	Slot5 CH15 IN	S5-15	Slot5 CH15 IN	INSCH91	InsertOut-CH91
S5-16	Slot5 CH16 IN	S5-16	Slot5 CH16 IN	INSCH92	InsertOut-CH92

input Channel Inputs		Input Channel insert Ins		Internal Effects Processor Inputs	
Port ID	Description	Port ID	Description	Port ID	Description
S6-1	Slot6 CH1 IN	S6-1	Slot6 CH1 IN	INSCH93	InsertOut-CH93
S6-2	Slot6 CH2 IN	S6-2	Slot6 CH2 IN	INSCH94	InsertOut-CH94
S6-3	Slot6 CH3 IN	S6-3	Slot6 CH3 IN	INSCH95	InsertOut-CH95
S6-4	Slot6 CH4 IN	S6-4	Slot6 CH4 IN	INSCH96	InsertOut-CH96
S6-5	Slot6 CH5 IN	S6-5	Slot6 CH5 IN	INSBUS1	InsertOut-BUS1
S6-6	Slot6 CH6 IN	S6-6	Slot6 CH6 IN	INSBUS2	InsertOut-BUS2
S6-7	Slot6 CH7 IN	S6-7	Slot6 CH7 IN	INSBUS3	InsertOut-BUS3
S6-8	Slot6 CH8 IN	S6-8	Slot6 CH8 IN	INSBUS4	InsertOut-BUS4
S6-9	Slot6 CH9 IN	S6-9	Slot6 CH9 IN	INSBUS5	InsertOut-BUS5
S6-10	Slot6 CH10 IN	S6-10	Slot6 CH10 IN	INSBUS6	InsertOut-BUS6
S6-11	Slot6 CH11 IN	S6-11	Slot6 CH11 IN	INSBUS7	InsertOut-BUS7
S6-12	Slot6 CH12 IN	S6-12	Slot6 CH12 IN	INSBUS8	InsertOut-BUS8
S6-13	Slot6 CH13 IN	S6-13	Slot6 CH13 IN	INSAUX1	InsertOut-AUX1
S6-14	Slot6 CH14 IN	S6-14	Slot6 CH14 IN	INSAUX2	InsertOut-AUX2
S6-15	Slot6 CH15 IN	S6-15	Slot6 CH15 IN	INSAUX3	InsertOut-AUX3
S6-16	Slot6 CH16 IN	S6-16	Slot6 CH16 IN	INSAUX4	InsertOut-AUX4
FX1-1	Effect1 OUT 1	FX1-1	Effect1 OUT 1	INSAUX5	InsertOut-AUX5
FX1-2	Effect1 OUT 2	FX1-2	Effect1 OUT 2	INSAUX6	InsertOut-AUX6
FX1-3	Effect1 OUT 3	FX1-3	Effect1 OUT 3	INSAUX7	InsertOut-AUX7
FX1-4	Effect1 OUT 4	FX1-4	Effect1 OUT 4	INSAUX8	InsertOut-AUX8
FX1-5	Effect1 OUT 5	FX1-5	Effect1 OUT 5	INSAUX9	InsertOut-AUX9
FX1-6	Effect1 OUT 6	FX1-6	Effect1 OUT 6	INSAUX10	InsertOut-AUX10
FX1-7	Effect1 OUT 7	FX1-7	Effect1 OUT 7	INSAUX11	InsertOut-AUX11
FX1-8	Effect1 OUT 8	FX1-8	Effect1 OUT 8	INSAUX12	InsertOut-AUX12
FX2-1	Effect2 OUT 1	FX2-1	Effect2 OUT 1	INSMTX1L	InsertOut-MTX1L
FX2-2	Effect2 OUT 2	FX2-2	Effect2 OUT 2	INSMTX1R	InsertOut-MTX1R
FX2-3	Effect2 OUT 3	FX2-3	Effect2 OUT 3	INSMTX2L	InsertOut-MTX2L
FX2-4	Effect2 OUT 4	FX2-4	Effect2 OUT 4	INSMTX2R	InsertOut-MTX2R
FX2-5	Effect2 OUT 5	FX2-5	Effect2 OUT 5	INSMTX3L	InsertOut-MTX3L
FX2-6	Effect2 OUT 6	FX2-6	Effect2 OUT 6	INSMTX3R	InsertOut-MTX3R
FX2-7	Effect2 OUT 7	FX2-7	Effect2 OUT 7	INSMTX4L	InsertOut-MTX4L
FX2-8	Effect2 OUT 8	FX2-8	Effect2 OUT 8	INSMTX4R	InsertOut-MTX4R
FX3-1	Effect3 OUT 1	FX3-1	Effect3 OUT 1	INSSTL	InsertOut-STL
FX3-2	Effect3 OUT 2	FX3-2	Effect3 OUT 2	INSSTR	InsertOut-STR
FX4-1	Effect4 OUT 1	FX4-1	Effect4 OUT 1	FX1-1	Effect1 OUT 1
FX4-2	Effect4 OUT 2	FX4-2	Effect4 OUT 2	FX1-2	Effect1 OUT 2
FX5-1	Effect5 OUT 1	FX5-1	Effect5 OUT 1	FX2-1	Effect2 OUT 1
FX5-2	Effect5 OUT 2	FX5-2	Effect5 OUT 2	FX2-2	Effect2 OUT 2
FX6-1	Effect6 OUT 1	FX6-1	Effect6 OUT 1	FX3-1	Effect3 OUT 1
FX6-2	Effect6 OUT 2	FX6-2	Effect6 OUT 2	FX3-2	Effect3 OUT 2
FX7-1	Effect7 OUT 1	FX7-1	Effect7 OUT 1	FX4-1	Effect4 OUT 1
FX7-2	Effect7 OUT 2	FX7-2	Effect7 OUT 2	FX4-2	Effect4 OUT 2
FX8-1	Effect8 OUT 1	FX8-1	Effect8 OUT 1	FX5-1	Effect5 OUT 1
FX8-2	Effect8 OUT 2	FX8-2	Effect8 OUT 2	FX5-2	Effect5 OUT 2
2TD1L	2TR IN Dig.1 L	2TD1L	2TR IN Dig.1 L	FX6-1	Effect6 OUT 1
2TD1R	2TR IN Dig.1 R	2TD1R	2TR IN Dig.1 R	FX6-2	Effect6 OUT 2
2TD2L	2TR IN Dig.2 L	2TD2L	2TR IN Dig.2 L	FX7-1	Effect7 OUT 1
2TD2R	2TR IN Dig.2 R	2TD2R	2TR IN Dig.2 R	FX7-2	Effect7 OUT 2
2TD3L	2TR IN Dig.3 L	2TD3L	2TR IN Dig.3 L	FX8-1	Effect8 OUT 1
2TD3R	2TR IN Dig.3 R	2TD3R	2TR IN Dig.3 R	FX8-2	Effect8 OUT 2
2TA1L	2TR IN Analog1 L	2TA1L	2TR IN Analog1 L	—	—
2TA1R	2TR IN Analog1 R	2TA1R	2TR IN Analog1 R	—	—
2TA2L	2TR IN Analog2 L	2TA2L	2TR IN Analog2 L	—	—



input Channel Inputs		Input Channel insert Ins		Internal Effects Processor Inputs	
Port ID	Description	Port ID	Description	Port ID	Description
2TA2R	2TR IN Analog2 R	2TA2R	2TR IN Analog2 R	—	—
BUS1	BUS1	—	—	—	—
BUS2	BUS2	—	—	—	—
BUS3	BUS3	—	—	—	—
BUS4	BUS4	—	—	—	—
BUS5	BUS5	—	—	—	—
BUS6	BUS6	—	—	—	—
BUS7	BUS7	—	—	—	—
BUS8	BUS8	—	—	—	—
AUX1	AUX1	—	—	—	—
AUX2	AUX2	—	—	—	—
AUX3	AUX3	—	—	—	—
AUX4	AUX4	—	—	—	—
AUX5	AUX5	—	—	—	—
AUX6	AUX6	—	—	—	—
AUX7	AUX7	—	—	—	—
AUX8	AUX8	—	—	—	—
AUX9	AUX9	—	—	—	—
AUX10	AUX10	—	—	—	—
AUX11	AUX11	—	—	—	—
AUX12	AUX12	—	—	—	—

## Initial Input Patch Settings

### Input Channel Inputs

Ch #	Source	Ch #	Source	Ch #	Source	Ch #	Source
1	AD01	25	S1-01	49	S4-01	73	FX1-1
2	AD02	26	S1-02	50	S4-02	74	FX1-2
3	AD03	27	S1-03	51	S4-03	75	FX2-1
4	AD04	28	S1-04	52	S4-04	76	FX2-2
5	AD05	29	S1-05	53	S4-05	77	FX3-1
6	AD06	30	S1-06	54	S4-06	78	FX3-2
7	AD07	31	S1-07	55	S4-07	79	FX4-1
8	AD08	32	S1-08	56	S4-08	80	FX4-2
9	AD09	33	S2-01	57	S5-01	81	FX5-1
10	AD10	34	S2-02	58	S5-02	82	FX5-2
11	AD11	35	S2-03	59	S5-03	83	FX6-1
12	AD12	36	S2-04	60	S5-04	84	FX6-2
13	AD13	37	S2-05	61	S5-05	85	FX7-1
14	AD14	38	S2-06	62	S5-06	86	FX7-2
15	AD15	39	S2-07	63	S5-07	87	FX8-1
16	AD16	40	S2-08	64	S5-08	88	FX8-2
17	AD17	41	S3-01	65	S6-01	89	2TD1L
18	AD18	42	S3-02	66	S6-02	90	2TD1R
19	AD19	43	S3-03	67	S6-03	91	2TD2L
20	AD20	44	S3-04	68	S6-04	92	2TD2R
21	AD21	45	S3-05	69	S6-05	93	2TA1L
22	AD22	46	S3-06	70	S6-06	94	2TA1R
23	AD23	47	S3-07	71	S6-07	95	2TA2L
24	AD24	48	S3-08	72	S6-08	96	2TA2R

### Effects Processors inputs

#	Source	#	Source
1-1	AUX1	2-7	NONE
1-2	NONE	2-8	NONE
1-3	NONE	3-1	AUX3
1-4	NONE	3-2	NONE
1-5	NONE	4-1	AUX4
1-6	NONE	4-2	NONE
1-7	NONE	5-1	AUX5
1-8	NONE	5-2	NONE
2-1	AUX2	6-1	AUX6
2-2	NONE	6-2	NONE
2-3	NONE	7-1	AUX7
2-4	NONE	7-2	NONE
2-5	NONE	8-1	AUX8
2-6	NONE	8-2	NONE

## Output Patch Parameters

Output patch parameters are split into two tables. The first table contains parameters for the Slot Outputs, Omni Outs, and Output Channel Insert Ins. The second table, Direct Outs, 2TR Digital Outputs, and the GEQs.

### Output Patch Table 1

Slot Outputs		Omni Outs		Output Channel Insert Ins	
Source	Description	Source	Description	Source	Description
NONE	NONE	NONE	NONE	NONE	NONE
BUS1	BUS1	BUS1	BUS1	AD1	AD IN 1
BUS2	BUS2	BUS2	BUS2	AD2	AD IN 2
BUS3	BUS3	BUS3	BUS3	AD3	AD IN 3
BUS4	BUS4	BUS4	BUS4	AD4	AD IN 4
BUS5	BUS5	BUS5	BUS5	AD5	AD IN 5
BUS6	BUS6	BUS6	BUS6	AD6	AD IN 6
BUS7	BUS7	BUS7	BUS7	AD7	AD IN 7
BUS8	BUS8	BUS8	BUS8	AD8	AD IN 8
AUX1	AUX1	AUX1	AUX1	AD9	AD IN 9
AUX2	AUX2	AUX2	AUX2	AD10	AD IN 10
AUX3	AUX3	AUX3	AUX3	AD11	AD IN 11
AUX4	AUX4	AUX4	AUX4	AD12	AD IN 12
AUX5	AUX5	AUX5	AUX5	AD13	AD IN 13
AUX6	AUX6	AUX6	AUX6	AD14	AD IN 14
AUX7	AUX7	AUX7	AUX7	AD15	AD IN 15
AUX8	AUX8	AUX8	AUX8	AD16	AD IN 16
AUX9	AUX9	AUX9	AUX9	AD17	AD IN 17
AUX10	AUX10	AUX10	AUX10	AD18	AD IN 18
AUX11	AUX11	AUX11	AUX11	AD19	AD IN 19
AUX12	AUX12	AUX12	AUX12	AD20	AD IN 20
MATRIX1L	MATRIX1 L	MATRIX1L	MATRIX1 L	AD21	AD IN 21
MATRIX1R	MATRIX1 R	MATRIX1R	MATRIX1 R	AD22	AD IN 22
MATRIX2L	MATRIX2 L	MATRIX2L	MATRIX2 L	AD23	AD IN 23
MATRIX2R	MATRIX2 R	MATRIX2R	MATRIX2 R	AD24	AD IN 24
MATRIX3L	MATRIX3 L	MATRIX3L	MATRIX3 L	S1-1	Slot1 CH1 IN
MATRIX3R	MATRIX3 R	MATRIX3R	MATRIX3 R	S1-2	Slot1 CH2 IN
MATRIX4L	MATRIX4 L	MATRIX4L	MATRIX4 L	S1-3	Slot1 CH3 IN
MATRIX4R	MATRIX4 R	MATRIX4R	MATRIX4 R	S1-4	Slot1 CH4 IN
STEREO-L	STEREO L	STEREO-L	STEREO L	S1-5	Slot1 CH5 IN
STEREO-R	STEREO R	STEREO-R	STEREO R	S1-6	Slot1 CH6 IN
INSCH1	InsertOut-CH1	INSCH1	InsertOut-CH1	S1-7	Slot1 CH7 IN
INSCH2	InsertOut-CH2	INSCH2	InsertOut-CH2	S1-8	Slot1 CH8 IN
INSCH3	InsertOut-CH3	INSCH3	InsertOut-CH3	S1-9	Slot1 CH9 IN
INSCH4	InsertOut-CH4	INSCH4	InsertOut-CH4	S1-10	Slot1 CH10 IN
INSCH5	InsertOut-CH5	INSCH5	InsertOut-CH5	S1-11	Slot1 CH11 IN
INSCH6	InsertOut-CH6	INSCH6	InsertOut-CH6	S1-12	Slot1 CH12 IN
INSCH7	InsertOut-CH7	INSCH7	InsertOut-CH7	S1-13	Slot1 CH13 IN
INSCH8	InsertOut-CH8	INSCH8	InsertOut-CH8	S1-14	Slot1 CH14 IN
INSCH9	InsertOut-CH9	INSCH9	InsertOut-CH9	S1-15	Slot1 CH15 IN
INSCH10	InsertOut-CH10	INSCH10	InsertOut-CH10	S1-16	Slot1 CH16 IN
INSCH11	InsertOut-CH11	INSCH11	InsertOut-CH11	S2-1	Slot2 CH1 IN
INSCH12	InsertOut-CH12	INSCH12	InsertOut-CH12	S2-2	Slot2 CH2 IN
INSCH13	InsertOut-CH13	INSCH13	InsertOut-CH13	S2-3	Slot2 CH3 IN
INSCH14	InsertOut-CH14	INSCH14	InsertOut-CH14	S2-4	Slot2 CH4 IN
INSCH15	InsertOut-CH15	INSCH15	InsertOut-CH15	S2-5	Slot2 CH5 IN

Slot Outputs		Omni Outs		Output Channel Insert Ins	
Source	Description	Source	Description	Source	Description
INSCH16	InsertOut-CH16	INSCH16	InsertOut-CH16	S2-6	Slot2 CH6 IN
INSCH17	InsertOut-CH17	INSCH17	InsertOut-CH17	S2-7	Slot2 CH7 IN
INSCH18	InsertOut-CH18	INSCH18	InsertOut-CH18	S2-8	Slot2 CH8 IN
INSCH19	InsertOut-CH19	INSCH19	InsertOut-CH19	S2-9	Slot2 CH9 IN
INSCH20	InsertOut-CH20	INSCH20	InsertOut-CH20	S2-10	Slot2 CH10 IN
INSCH21	InsertOut-CH21	INSCH21	InsertOut-CH21	S2-11	Slot2 CH11 IN
INSCH22	InsertOut-CH22	INSCH22	InsertOut-CH22	S2-12	Slot2 CH12 IN
INSCH23	InsertOut-CH23	INSCH23	InsertOut-CH23	S2-13	Slot2 CH13 IN
INSCH24	InsertOut-CH24	INSCH24	InsertOut-CH24	S2-14	Slot2 CH14 IN
INSCH25	InsertOut-CH25	INSCH25	InsertOut-CH25	S2-15	Slot2 CH15 IN
INSCH26	InsertOut-CH26	INSCH26	InsertOut-CH26	S2-16	Slot2 CH16 IN
INSCH27	InsertOut-CH27	INSCH27	InsertOut-CH27	S3-1	Slot3 CH1 IN
INSCH28	InsertOut-CH28	INSCH28	InsertOut-CH28	S3-2	Slot3 CH2 IN
INSCH29	InsertOut-CH29	INSCH29	InsertOut-CH29	S3-3	Slot3 CH3 IN
INSCH30	InsertOut-CH30	INSCH30	InsertOut-CH30	S3-4	Slot3 CH4 IN
INSCH31	InsertOut-CH31	INSCH31	InsertOut-CH31	S3-5	Slot3 CH5 IN
INSCH32	InsertOut-CH32	INSCH32	InsertOut-CH32	S3-6	Slot3 CH6 IN
INSCH33	InsertOut-CH33	INSCH33	InsertOut-CH33	S3-7	Slot3 CH7 IN
INSCH34	InsertOut-CH34	INSCH34	InsertOut-CH34	S3-8	Slot3 CH8 IN
INSCH35	InsertOut-CH35	INSCH35	InsertOut-CH35	S3-9	Slot3 CH9 IN
INSCH36	InsertOut-CH36	INSCH36	InsertOut-CH36	S3-10	Slot3 CH10 IN
INSCH37	InsertOut-CH37	INSCH37	InsertOut-CH37	S3-11	Slot3 CH11 IN
INSCH38	InsertOut-CH38	INSCH38	InsertOut-CH38	S3-12	Slot3 CH12 IN
INSCH39	InsertOut-CH39	INSCH39	InsertOut-CH39	S3-13	Slot3 CH13 IN
INSCH40	InsertOut-CH40	INSCH40	InsertOut-CH40	S3-14	Slot3 CH14 IN
INSCH41	InsertOut-CH41	INSCH41	InsertOut-CH41	S3-15	Slot3 CH15 IN
INSCH42	InsertOut-CH42	INSCH42	InsertOut-CH42	S3-16	Slot3 CH16 IN
INSCH43	InsertOut-CH43	INSCH43	InsertOut-CH43	S4-1	Slot4 CH1 IN
INSCH44	InsertOut-CH44	INSCH44	InsertOut-CH44	S4-2	Slot4 CH2 IN
INSCH45	InsertOut-CH45	INSCH45	InsertOut-CH45	S4-3	Slot4 CH3 IN
INSCH46	InsertOut-CH46	INSCH46	InsertOut-CH46	S4-4	Slot4 CH4 IN
INSCH47	InsertOut-CH47	INSCH47	InsertOut-CH47	S4-5	Slot4 CH5 IN
INSCH48	InsertOut-CH48	INSCH48	InsertOut-CH48	S4-6	Slot4 CH6 IN
INSCH49	InsertOut-CH49	INSCH49	InsertOut-CH49	S4-7	Slot4 CH7 IN
INSCH50	InsertOut-CH50	INSCH50	InsertOut-CH50	S4-8	Slot4 CH8 IN
INSCH51	InsertOut-CH51	INSCH51	InsertOut-CH51	S4-9	Slot4 CH9 IN
INSCH52	InsertOut-CH52	INSCH52	InsertOut-CH52	S4-10	Slot4 CH10 IN
INSCH53	InsertOut-CH53	INSCH53	InsertOut-CH53	S4-11	Slot4 CH11 IN
INSCH54	InsertOut-CH54	INSCH54	InsertOut-CH54	S4-12	Slot4 CH12 IN
INSCH55	InsertOut-CH55	INSCH55	InsertOut-CH55	S4-13	Slot4 CH13 IN
INSCH56	InsertOut-CH56	INSCH56	InsertOut-CH56	S4-14	Slot4 CH14 IN
INSCH57	InsertOut-CH57	INSCH57	InsertOut-CH57	S4-15	Slot4 CH15 IN
INSCH58	InsertOut-CH58	INSCH58	InsertOut-CH58	S4-16	Slot4 CH16 IN
INSCH59	InsertOut-CH59	INSCH59	InsertOut-CH59	S5-1	Slot5 CH1 IN
INSCH60	InsertOut-CH60	INSCH60	InsertOut-CH60	S5-2	Slot5 CH2 IN
INSCH61	InsertOut-CH61	INSCH61	InsertOut-CH61	S5-3	Slot5 CH3 IN
INSCH62	InsertOut-CH62	INSCH62	InsertOut-CH62	S5-4	Slot5 CH4 IN
INSCH63	InsertOut-CH63	INSCH63	InsertOut-CH63	S5-5	Slot5 CH5 IN
INSCH64	InsertOut-CH64	INSCH64	InsertOut-CH64	S5-6	Slot5 CH6 IN
INSCH65	InsertOut-CH65	INSCH65	InsertOut-CH65	S5-7	Slot5 CH7 IN
INSCH66	InsertOut-CH66	INSCH66	InsertOut-CH66	S5-8	Slot5 CH8 IN
INSCH67	InsertOut-CH67	INSCH67	InsertOut-CH67	S5-9	Slot5 CH9 IN
INSCH68	InsertOut-CH68	INSCH68	InsertOut-CH68	S5-10	Slot5 CH10 IN

Slot Outputs		Omni Outs		Output Channel Insert Ins	
Source	Description	Source	Description	Source	Description
INSCH69	InsertOut-CH69	INSCH69	InsertOut-CH69	S5-11	Slot5 CH11 IN
INSCH70	InsertOut-CH70	INSCH70	InsertOut-CH70	S5-12	Slot5 CH12 IN
INSCH71	InsertOut-CH71	INSCH71	InsertOut-CH71	S5-13	Slot5 CH13 IN
INSCH72	InsertOut-CH72	INSCH72	InsertOut-CH72	S5-14	Slot5 CH14 IN
INSCH73	InsertOut-CH73	INSCH73	InsertOut-CH73	S5-15	Slot5 CH15 IN
INSCH74	InsertOut-CH74	INSCH74	InsertOut-CH74	S5-16	Slot5 CH16 IN
INSCH75	InsertOut-CH75	INSCH75	InsertOut-CH75	S6-1	Slot6 CH1 IN
INSCH76	InsertOut-CH76	INSCH76	InsertOut-CH76	S6-2	Slot6 CH2 IN
INSCH77	InsertOut-CH77	INSCH77	InsertOut-CH77	S6-3	Slot6 CH3 IN
INSCH78	InsertOut-CH78	INSCH78	InsertOut-CH78	S6-4	Slot6 CH4 IN
INSCH79	InsertOut-CH79	INSCH79	InsertOut-CH79	S6-5	Slot6 CH5 IN
INSCH80	InsertOut-CH80	INSCH80	InsertOut-CH80	S6-6	Slot6 CH6 IN
INSCH81	InsertOut-CH81	INSCH81	InsertOut-CH81	S6-7	Slot6 CH7 IN
INSCH82	InsertOut-CH82	INSCH82	InsertOut-CH82	S6-8	Slot6 CH8 IN
INSCH83	InsertOut-CH83	INSCH83	InsertOut-CH83	S6-9	Slot6 CH9 IN
INSCH84	InsertOut-CH84	INSCH84	InsertOut-CH84	S6-10	Slot6 CH10 IN
INSCH85	InsertOut-CH85	INSCH85	InsertOut-CH85	S6-11	Slot6 CH11 IN
INSCH86	InsertOut-CH86	INSCH86	InsertOut-CH86	S6-12	Slot6 CH12 IN
INSCH87	InsertOut-CH87	INSCH87	InsertOut-CH87	S6-13	Slot6 CH13 IN
INSCH88	InsertOut-CH88	INSCH88	InsertOut-CH88	S6-14	Slot6 CH14 IN
INSCH89	InsertOut-CH89	INSCH89	InsertOut-CH89	S6-15	Slot6 CH15 IN
INSCH90	InsertOut-CH90	INSCH90	InsertOut-CH90	S6-16	Slot6 CH16 IN
INSCH91	InsertOut-CH91	INSCH91	InsertOut-CH91	FX1-1	Effect1 OUT 1
INSCH92	InsertOut-CH92	INSCH92	InsertOut-CH92	FX1-2	Effect1 OUT 2
INSCH93	InsertOut-CH93	INSCH93	InsertOut-CH93	FX1-3	Effect1 OUT 3
INSCH94	InsertOut-CH94	INSCH94	InsertOut-CH94	FX1-4	Effect1 OUT 4
INSCH95	InsertOut-CH95	INSCH95	InsertOut-CH95	FX1-5	Effect1 OUT 5
INSCH96	InsertOut-CH96	INSCH96	InsertOut-CH96	FX1-6	Effect1 OUT 6
INSBUS1	InsertOut-BUS1	INSBUS1	InsertOut-BUS1	FX1-7	Effect1 OUT 7
INSBUS2	InsertOut-BUS2	INSBUS2	InsertOut-BUS2	FX1-8	Effect1 OUT 8
INSBUS3	InsertOut-BUS3	INSBUS3	InsertOut-BUS3	FX2-1	Effect2 OUT 1
INSBUS4	InsertOut-BUS4	INSBUS4	InsertOut-BUS4	FX2-2	Effect2 OUT 2
INSBUS5	InsertOut-BUS5	INSBUS5	InsertOut-BUS5	FX2-3	Effect2 OUT 3
INSBUS6	InsertOut-BUS6	INSBUS6	InsertOut-BUS6	FX2-4	Effect2 OUT 4
INSBUS7	InsertOut-BUS7	INSBUS7	InsertOut-BUS7	FX2-5	Effect2 OUT 5
INSBUS8	InsertOut-BUS8	INSBUS8	InsertOut-BUS8	FX2-6	Effect2 OUT 6
INSAUX1	InsertOut-AUX1	INSAUX1	InsertOut-AUX1	FX2-7	Effect2 OUT 7
INSAUX2	InsertOut-AUX2	INSAUX2	InsertOut-AUX2	FX2-8	Effect2 OUT 8
INSAUX3	InsertOut-AUX3	INSAUX3	InsertOut-AUX3	FX3-1	Effect3 OUT 1
INSAUX4	InsertOut-AUX4	INSAUX4	InsertOut-AUX4	FX3-2	Effect3 OUT 2
INSAUX5	InsertOut-AUX5	INSAUX5	InsertOut-AUX5	FX4-1	Effect4 OUT 1
INSAUX6	InsertOut-AUX6	INSAUX6	InsertOut-AUX6	FX4-2	Effect4 OUT 2
INSAUX7	InsertOut-AUX7	INSAUX7	InsertOut-AUX7	FX5-1	Effect5 OUT 1
INSAUX8	InsertOut-AUX8	INSAUX8	InsertOut-AUX8	FX5-2	Effect5 OUT 2
INSAUX9	InsertOut-AUX9	INSAUX9	InsertOut-AUX9	FX6-1	Effect6 OUT 1
INSAUX10	InsertOut-AUX10	INSAUX10	InsertOut-AUX10	FX6-2	Effect6 OUT 2
INSAUX11	InsertOut-AUX11	INSAUX11	InsertOut-AUX11	FX7-1	Effect7 OUT 1
INSAUX12	InsertOut-AUX12	INSAUX12	InsertOut-AUX12	FX7-2	Effect7 OUT 2
INSMTX1L	InsertOut-MTX1L	INSMTX1L	InsertOut-MTX1L	FX8-1	Effect8 OUT 1
INSMTX1R	InsertOut-MTX1R	INSMTX1R	InsertOut-MTX1R	FX8-2	Effect8 OUT 2
INSMTX2L	InsertOut-MTX2L	INSMTX2L	InsertOut-MTX2L	2TD1L	2TR IN Dig.1 L
INSMTX2R	InsertOut-MTX2R	INSMTX2R	InsertOut-MTX2R	2TD1R	2TR IN Dig.1 R
INSMTX3L	InsertOut-MTX3L	INSMTX3L	InsertOut-MTX3L	2TD2L	2TR IN Dig.2 L

Slot Outputs		Omni Outs		Output Channel Insert Ins	
Source	Description	Source	Description	Source	Description
INSMTX3R	InsertOut-MTX3R	INSMTX3R	InsertOut-MTX3R	2TD2R	2TR IN Dig.2 R
INSMTX4L	InsertOut-MTX4L	INSMTX4L	InsertOut-MTX4L	2TD3L	2TR IN Dig.3 L
INSMTX4R	InsertOut-MTX4R	INSMTX4R	InsertOut-MTX4R	2TD3R	2TR IN Dig.3 R
INSSTL	InsertOut-STL	INSSTL	InsertOut-STL	2TA1L	2TR IN Analog1 L
INSSTR	InsertOut-STR	INSSTR	InsertOut-STR	2TA1R	2TR IN Analog1 R
Surr L	Surround Monitor L	Surr L	Surround Monitor L	2TA2L	2TR IN Analog2 L
Surr R	Surround Monitor R	Surr R	Surround Monitor R	2TA2R	2TR IN Analog2 R
Surr Ls	Surround Monitor Ls	Surr Ls	Surround Monitor Ls	—	—
Surr Rs	Surround Monitor Rs	Surr Rs	Surround Monitor Rs	—	—
Surr C	Surround Monitor C	Surr C	Surround Monitor C	—	—
Surr LFE	Surround Monitor LFE	Surr LFE	Surround Monitor LFE	—	—
Surr Ls2	Surround Monitor Ls2	Surr Ls2	Surround Monitor Ls2	—	—
Surr Rs2	Surround Monitor Rs2	Surr Rs2	Surround Monitor Rs2	—	—

## Output Patch Table 2

Direct Outs		2TR Digital Outs		GEQs	
Source	Description	Source	Description	Source	Description
NONE	NONE	NONE	NONE	NONE	NONE
S1-1	Slot1 CH1 OUT	BUS1	BUS1	BUS1	BUS1
S1-2	Slot1 CH2 OUT	BUS2	BUS2	BUS2	BUS2
S1-3	Slot1 CH3 OUT	BUS3	BUS3	BUS3	BUS3
S1-4	Slot1 CH4 OUT	BUS4	BUS4	BUS4	BUS4
S1-5	Slot1 CH5 OUT	BUS5	BUS5	BUS5	BUS5
S1-6	Slot1 CH6 OUT	BUS6	BUS6	BUS6	BUS6
S1-7	Slot1 CH7 OUT	BUS7	BUS7	BUS7	BUS7
S1-8	Slot1 CH8 OUT	BUS8	BUS8	BUS8	BUS8
S1-9	Slot1 CH9 OUT	AUX1	AUX1	AUX1	AUX1
S1-10	Slot1 CH10 OUT	AUX2	AUX2	AUX2	AUX2
S1-11	Slot1 CH11 OUT	AUX3	AUX3	AUX3	AUX3
S1-12	Slot1 CH12 OUT	AUX4	AUX4	AUX4	AUX4
S1-13	Slot1 CH13 OUT	AUX5	AUX5	AUX5	AUX5
S1-14	Slot1 CH14 OUT	AUX6	AUX6	AUX6	AUX6
S1-15	Slot1 CH15 OUT	AUX7	AUX7	AUX7	AUX7
S1-16	Slot1 CH16 OUT	AUX8	AUX8	AUX8	AUX8
S2-1	Slot2 CH1 OUT	AUX9	AUX9	AUX9	AUX9
S2-2	Slot2 CH2 OUT	AUX10	AUX10	AUX10	AUX10
S2-3	Slot2 CH3 OUT	AUX11	AUX11	AUX11	AUX11
S2-4	Slot2 CH4 OUT	AUX12	AUX12	AUX12	AUX12
S2-5	Slot2 CH5 OUT	MATRIX1L	MATRIX1 L	MATRIX1L	MATRIX1 L
S2-6	Slot2 CH6 OUT	MATRIX1R	MATRIX1 R	MATRIX1R	MATRIX1 R
S2-7	Slot2 CH7 OUT	MATRIX2L	MATRIX2 L	MATRIX2L	MATRIX2 L
S2-8	Slot2 CH8 OUT	MATRIX2R	MATRIX2 R	MATRIX2R	MATRIX2 R
S2-9	Slot2 CH9 OUT	MATRIX3L	MATRIX3 L	MATRIX3L	MATRIX3 L
S2-10	Slot2 CH10 OUT	MATRIX3R	MATRIX3 R	MATRIX3R	MATRIX3 R
S2-11	Slot2 CH11 OUT	MATRIX4L	MATRIX4 L	MATRIX4L	MATRIX4 L
S2-12	Slot2 CH12 OUT	MATRIX4R	MATRIX4 R	MATRIX4R	MATRIX4 R
S2-13	Slot2 CH13 OUT	STEREO-L	STEREO L	STEREO-L	STEREO L
S2-14	Slot2 CH14 OUT	STEREO-R	STEREO R	STEREO-R	STEREO R
S2-15	Slot2 CH15 OUT	INSCH1	InsertOut-CH1	—	—
S2-16	Slot2 CH16 OUT	INSCH2	InsertOut-CH2	—	—
S3-1	Slot3 CH1 OUT	INSCH3	InsertOut-CH3	—	—
S3-2	Slot3 CH2 OUT	INSCH4	InsertOut-CH4	—	—
S3-3	Slot3 CH3 OUT	INSCH5	InsertOut-CH5	—	—
S3-4	Slot3 CH4 OUT	INSCH6	InsertOut-CH6	—	—
S3-5	Slot3 CH5 OUT	INSCH7	InsertOut-CH7	—	—
S3-6	Slot3 CH6 OUT	INSCH8	InsertOut-CH8	—	—
S3-7	Slot3 CH7 OUT	INSCH9	InsertOut-CH9	—	—
S3-8	Slot3 CH8 OUT	INSCH10	InsertOut-CH10	—	—
S3-9	Slot3 CH9 OUT	INSCH11	InsertOut-CH11	—	—
S3-10	Slot3 CH10 OUT	INSCH12	InsertOut-CH12	—	—
S3-11	Slot3 CH11 OUT	INSCH13	InsertOut-CH13	—	—
S3-12	Slot3 CH12 OUT	INSCH14	InsertOut-CH14	—	—
S3-13	Slot3 CH13 OUT	INSCH15	InsertOut-CH15	—	—
S3-14	Slot3 CH14 OUT	INSCH16	InsertOut-CH16	—	—
S3-15	Slot3 CH15 OUT	INSCH17	InsertOut-CH17	—	—
S3-16	Slot3 CH16 OUT	INSCH18	InsertOut-CH18	—	—
S4-1	Slot4 CH1 OUT	INSCH19	InsertOut-CH19	—	—
S4-2	Slot4 CH2 OUT	INSCH20	InsertOut-CH20	—	—
S4-3	Slot4 CH3 OUT	INSCH21	InsertOut-CH21	—	—

Direct Outs		2TR Digital Outs		GEQs	
Source	Description	Source	Description	Source	Description
S4-4	Slot4 CH4 OUT	INSCH22	InsertOut-CH22	—	—
S4-5	Slot4 CH5 OUT	INSCH23	InsertOut-CH23	—	—
S4-6	Slot4 CH6 OUT	INSCH24	InsertOut-CH24	—	—
S4-7	Slot4 CH7 OUT	INSCH25	InsertOut-CH25	—	—
S4-8	Slot4 CH8 OUT	INSCH26	InsertOut-CH26	—	—
S4-9	Slot4 CH9 OUT	INSCH27	InsertOut-CH27	—	—
S4-10	Slot4 CH10 OUT	INSCH28	InsertOut-CH28	—	—
S4-11	Slot4 CH11 OUT	INSCH29	InsertOut-CH29	—	—
S4-12	Slot4 CH12 OUT	INSCH30	InsertOut-CH30	—	—
S4-13	Slot4 CH13 OUT	INSCH31	InsertOut-CH31	—	—
S4-14	Slot4 CH14 OUT	INSCH32	InsertOut-CH32	—	—
S4-15	Slot4 CH15 OUT	INSCH33	InsertOut-CH33	—	—
S4-16	Slot4 CH16 OUT	INSCH34	InsertOut-CH34	—	—
S5-1	Slot5 CH1 OUT	INSCH35	InsertOut-CH35	—	—
S5-2	Slot5 CH2 OUT	INSCH36	InsertOut-CH36	—	—
S5-3	Slot5 CH3 OUT	INSCH37	InsertOut-CH37	—	—
S5-4	Slot5 CH4 OUT	INSCH38	InsertOut-CH38	—	—
S5-5	Slot5 CH5 OUT	INSCH39	InsertOut-CH39	—	—
S5-6	Slot5 CH6 OUT	INSCH40	InsertOut-CH40	—	—
S5-7	Slot5 CH7 OUT	INSCH41	InsertOut-CH41	—	—
S5-8	Slot5 CH8 OUT	INSCH42	InsertOut-CH42	—	—
S5-9	Slot5 CH9 OUT	INSCH43	InsertOut-CH43	—	—
S5-10	Slot5 CH10 OUT	INSCH44	InsertOut-CH44	—	—
S5-11	Slot5 CH11 OUT	INSCH45	InsertOut-CH45	—	—
S5-12	Slot5 CH12 OUT	INSCH46	InsertOut-CH46	—	—
S5-13	Slot5 CH13 OUT	INSCH47	InsertOut-CH47	—	—
S5-14	Slot5 CH14 OUT	INSCH48	InsertOut-CH48	—	—
S5-15	Slot5 CH15 OUT	INSCH49	InsertOut-CH49	—	—
S5-16	Slot5 CH16 OUT	INSCH50	InsertOut-CH50	—	—
S6-1	Slot6 CH1 OUT	INSCH51	InsertOut-CH51	—	—
S6-2	Slot6 CH2 OUT	INSCH52	InsertOut-CH52	—	—
S6-3	Slot6 CH3 OUT	INSCH53	InsertOut-CH53	—	—
S6-4	Slot6 CH4 OUT	INSCH54	InsertOut-CH54	—	—
S6-5	Slot6 CH5 OUT	INSCH55	InsertOut-CH55	—	—
S6-6	Slot6 CH6 OUT	INSCH56	InsertOut-CH56	—	—
S6-7	Slot6 CH7 OUT	INSCH57	InsertOut-CH57	—	—
S6-8	Slot6 CH8 OUT	INSCH58	InsertOut-CH58	—	—
S6-9	Slot6 CH9 OUT	INSCH59	InsertOut-CH59	—	—
S6-10	Slot6 CH10 OUT	INSCH60	InsertOut-CH60	—	—
S6-11	Slot6 CH11 OUT	INSCH61	InsertOut-CH61	—	—
S6-12	Slot6 CH12 OUT	INSCH62	InsertOut-CH62	—	—
S6-13	Slot6 CH13 OUT	INSCH63	InsertOut-CH63	—	—
S6-14	Slot6 CH14 OUT	INSCH64	InsertOut-CH64	—	—
S6-15	Slot6 CH15 OUT	INSCH65	InsertOut-CH65	—	—
S6-16	Slot6 CH16 OUT	INSCH66	InsertOut-CH66	—	—
OMNI1	OMNI OUT 1	INSCH67	InsertOut-CH67	—	—
OMNI2	OMNI OUT 2	INSCH68	InsertOut-CH68	—	—
OMNI3	OMNI OUT 3	INSCH69	InsertOut-CH69	—	—
OMNI4	OMNI OUT 4	INSCH70	InsertOut-CH70	—	—
OMNI5	OMNI OUT 5	INSCH71	InsertOut-CH71	—	—
OMNI6	OMNI OUT 6	INSCH72	InsertOut-CH72	—	—
OMNI7	OMNI OUT 7	INSCH73	InsertOut-CH73	—	—
OMNI8	OMNI OUT 8	INSCH74	InsertOut-CH74	—	—
2TD1L	2TR OUT Dig.1 L	INSCH75	InsertOut-CH75	—	—

Direct Outs		2TR Digital Outs		GEQs	
Source	Description	Source	Description	Source	Description
2TD1R	2TR OUT Dig.1 R	INSCH76	InsertOut-CH76	—	—
2TD2L	2TR OUT Dig.2 L	INSCH77	InsertOut-CH77	—	—
2TD2R	2TR OUT Dig.2 R	INSCH78	InsertOut-CH78	—	—
2TD3L	2TR OUT Dig.3 L	INSCH79	InsertOut-CH79	—	—
2TD3R	2TR OUT Dig.3 R	INSCH80	InsertOut-CH80	—	—
—	—	INSCH81	InsertOut-CH81	—	—
—	—	INSCH82	InsertOut-CH82	—	—
—	—	INSCH83	InsertOut-CH83	—	—
—	—	INSCH84	InsertOut-CH84	—	—
—	—	INSCH85	InsertOut-CH85	—	—
—	—	INSCH86	InsertOut-CH86	—	—
—	—	INSCH87	InsertOut-CH87	—	—
—	—	INSCH88	InsertOut-CH88	—	—
—	—	INSCH89	InsertOut-CH89	—	—
—	—	INSCH90	InsertOut-CH90	—	—
—	—	INSCH91	InsertOut-CH91	—	—
—	—	INSCH92	InsertOut-CH92	—	—
—	—	INSCH93	InsertOut-CH93	—	—
—	—	INSCH94	InsertOut-CH94	—	—
—	—	INSCH95	InsertOut-CH95	—	—
—	—	INSCH96	InsertOut-CH96	—	—
—	—	INSBUS1	InsertOut-BUS1	—	—
—	—	INSBUS2	InsertOut-BUS2	—	—
—	—	INSBUS3	InsertOut-BUS3	—	—
—	—	INSBUS4	InsertOut-BUS4	—	—
—	—	INSBUS5	InsertOut-BUS5	—	—
—	—	INSBUS6	InsertOut-BUS6	—	—
—	—	INSBUS7	InsertOut-BUS7	—	—
—	—	INSBUS8	InsertOut-BUS8	—	—
—	—	INSAUX1	InsertOut-AUX1	—	—
—	—	INSAUX2	InsertOut-AUX2	—	—
—	—	INSAUX3	InsertOut-AUX3	—	—
—	—	INSAUX4	InsertOut-AUX4	—	—
—	—	INSAUX5	InsertOut-AUX5	—	—
—	—	INSAUX6	InsertOut-AUX6	—	—
—	—	INSAUX7	InsertOut-AUX7	—	—
—	—	INSAUX8	InsertOut-AUX8	—	—
—	—	INSAUX9	InsertOut-AUX9	—	—
—	—	INSAUX10	InsertOut-AUX10	—	—
—	—	INSAUX11	InsertOut-AUX11	—	—
—	—	INSAUX12	InsertOut-AUX12	—	—
—	—	INSMTX1L	InsertOut-MTX1L	—	—
—	—	INSMTX1R	InsertOut-MTX1R	—	—
—	—	INSMTX2L	InsertOut-MTX2L	—	—
—	—	INSMTX2R	InsertOut-MTX2R	—	—
—	—	INSMTX3L	InsertOut-MTX3L	—	—
—	—	INSMTX3R	InsertOut-MTX3R	—	—
—	—	INSMTX4L	InsertOut-MTX4L	—	—
—	—	INSMTX4R	InsertOut-MTX4R	—	—
—	—	INSSTL	InsertOut-STL	—	—
—	—	INSSTR	InsertOut-STR	—	—
—	—	CR-L	Control Room L	—	—
—	—	CR-R	Control Room R	—	—



## Initial Output Patch Settings

Slot Outputs		Omni Outs		Direct Outs	
#	Source	#	Source		Destination
SLOT1-01	BUS1	1	AUX1	1	SLOT1-01
SLOT1-02	BUS2	2	AUX2	2	SLOT1-02
SLOT1-03	BUS3	3	AUX3	3	SLOT1-03
SLOT1-04	BUS4	4	AUX4	4	SLOT1-04
SLOT1-05	BUS5	5	AUX5	5	SLOT1-05
SLOT1-06	BUS6	6	AUX6	6	SLOT1-06
SLOT1-07	BUS7	7	AUX7	7	SLOT1-07
SLOT1-08	BUS8	8	AUX8	8	SLOT1-08
SLOT1-09	BUS1	—	—	9	SLOT2-01
SLOT1-10	BUS2	—	—	10	SLOT2-02
SLOT1-11	BUS3	—	—	11	SLOT2-03
SLOT1-12	BUS4	—	—	12	SLOT2-04
SLOT1-13	BUS5	—	—	13	SLOT2-05
SLOT1-14	BUS6	—	—	14	SLOT2-06
SLOT1-15	BUS7	—	—	15	SLOT2-07
SLOT1-16	BUS8	—	—	16	SLOT2-08
SLOT2-01	BUS1	—	—	17	SLOT3-01
SLOT2-02	BUS2	—	—	18	SLOT3-02
SLOT2-03	BUS3	—	—	19	SLOT3-03
SLOT2-04	BUS4	—	—	20	SLOT3-04
SLOT2-05	BUS5	—	—	21	SLOT3-05
SLOT2-06	BUS6	—	—	22	SLOT3-06
SLOT2-07	BUS7	—	—	23	SLOT3-07
SLOT2-08	BUS8	—	—	24	SLOT3-08
SLOT2-09	BUS1	—	—	25	SLOT4-01
SLOT2-10	BUS2	—	—	26	SLOT4-02
SLOT2-11	BUS3	—	—	27	SLOT4-03
SLOT2-12	BUS4	—	—	28	SLOT4-04
SLOT2-13	BUS5	—	—	29	SLOT4-05
SLOT2-14	BUS6	—	—	30	SLOT4-06
SLOT2-15	BUS7	—	—	31	SLOT4-07
SLOT2-16	BUS8	—	—	32	SLOT4-08
SLOT3-01	BUS1	—	—	33	SLOT5-01
SLOT3-02	BUS2	—	—	34	SLOT5-02
SLOT3-03	BUS3	—	—	35	SLOT5-03
SLOT3-04	BUS4	—	—	36	SLOT5-04
SLOT3-05	BUS5	—	—	37	SLOT5-05
SLOT3-06	BUS6	—	—	38	SLOT5-06
SLOT3-07	BUS7	—	—	39	SLOT5-07
SLOT3-08	BUS8	—	—	40	SLOT5-08
SLOT3-09	BUS1	—	—	41	SLOT6-01
SLOT3-10	BUS2	—	—	42	SLOT6-02
SLOT3-11	BUS3	—	—	43	SLOT6-03
SLOT3-12	BUS4	—	—	44	SLOT6-04
SLOT3-13	BUS5	—	—	45	SLOT6-05
SLOT3-14	BUS6	—	—	46	SLOT6-06
SLOT3-15	BUS7	—	—	47	SLOT6-07
SLOT3-16	BUS8	—	—	48	SLOT6-08
SLOT4-01	BUS1	—	—	49	NONE
SLOT4-02	BUS2	—	—	50	NONE
SLOT4-03	BUS3	—	—	51	NONE
SLOT4-04	BUS4	—	—	52	NONE

Slot Outputs		Omni Outs		Direct Outs	
#	Source	#	Source		Destination
SLOT4-05	BUS5	—	—	53	NONE
SLOT4-06	BUS6	—	—	54	NONE
SLOT4-07	BUS7	—	—	55	NONE
SLOT4-08	BUS8	—	—	56	NONE
SLOT4-09	BUS1	—	—	57	NONE
SLOT4-10	BUS2	—	—	58	NONE
SLOT4-11	BUS3	—	—	59	NONE
SLOT4-12	BUS4	—	—	60	NONE
SLOT4-13	BUS5	—	—	61	NONE
SLOT4-14	BUS6	—	—	62	NONE
SLOT4-15	BUS7	—	—	63	NONE
SLOT4-16	BUS8	—	—	64	NONE
SLOT5-01	BUS1	—	—	65	NONE
SLOT5-02	BUS2	—	—	66	NONE
SLOT5-03	BUS3	—	—	67	NONE
SLOT5-04	BUS4	—	—	68	NONE
SLOT5-05	BUS5	—	—	69	NONE
SLOT5-06	BUS6	—	—	70	NONE
SLOT5-07	BUS7	—	—	71	NONE
SLOT5-08	BUS8	—	—	72	NONE
SLOT5-09	BUS1	—	—	73	NONE
SLOT5-10	BUS2	—	—	74	NONE
SLOT5-11	BUS3	—	—	75	NONE
SLOT5-12	BUS4	—	—	76	NONE
SLOT5-13	BUS5	—	—	77	NONE
SLOT5-14	BUS6	—	—	78	NONE
SLOT5-15	BUS7	—	—	79	NONE
SLOT5-16	BUS8	—	—	80	NONE
SLOT6-01	BUS1	—	—	81	NONE
SLOT6-02	BUS2	—	—	82	NONE
SLOT6-03	BUS3	—	—	83	NONE
SLOT6-04	BUS4	—	—	84	NONE
SLOT6-05	BUS5	—	—	85	NONE
SLOT6-06	BUS6	—	—	86	NONE
SLOT6-07	BUS7	—	—	87	NONE
SLOT6-08	BUS8	—	—	88	NONE
SLOT6-09	BUS1	—	—	89	NONE
SLOT6-10	BUS2	—	—	90	NONE
SLOT6-11	BUS3	—	—	91	NONE
SLOT6-12	BUS4	—	—	92	NONE
SLOT6-13	BUS5	—	—	93	NONE
SLOT6-14	BUS6	—	—	94	NONE
SLOT6-15	BUS7	—	—	95	NONE
SLOT6-16	BUS8	—	—	96	NONE

## Initial Input Channel Names

Input Channel ID	Short Name	Long Name
CH01	CH01	CH01
CH02	CH02	CH02
CH03	CH03	CH03
CH04	CH04	CH04
CH05	CH05	CH05
CH06	CH06	CH06
CH07	CH07	CH07
CH08	CH08	CH08
CH09	CH09	CH09
CH10	CH10	CH10
CH11	CH11	CH11
CH12	CH12	CH12
CH13	CH13	CH13
CH14	CH14	CH14
CH15	CH15	CH15
CH16	CH16	CH16
CH17	CH17	CH17
CH18	CH18	CH18
CH19	CH19	CH19
CH20	CH20	CH20
CH21	CH21	CH21
CH22	CH22	CH22
CH23	CH23	CH23
CH24	CH24	CH24
CH25	CH25	CH25
CH26	CH26	CH26
CH27	CH27	CH27
CH28	CH28	CH28
CH29	CH29	CH29
CH30	CH30	CH30
CH31	CH31	CH31
CH32	CH32	CH32
CH33	CH33	CH33
CH34	CH34	CH34
CH35	CH35	CH35
CH36	CH36	CH36
CH37	CH37	CH37
CH38	CH38	CH38
CH39	CH39	CH39
CH40	CH40	CH40
CH41	CH41	CH41
CH42	CH42	CH42
CH43	CH43	CH43
CH44	CH44	CH44
CH45	CH45	CH45
CH46	CH46	CH46
CH47	CH47	CH47
CH48	CH48	CH48
CH49	CH49	CH49
CH50	CH50	CH50
CH51	CH51	CH51
CH52	CH52	CH52

Input Channel ID	Short Name	Long Name
CH53	CH53	CH53
CH54	CH54	CH54
CH55	CH55	CH55
CH56	CH56	CH56
CH57	CH57	CH57
CH58	CH58	CH58
CH59	CH59	CH59
CH60	CH60	CH60
CH61	CH61	CH61
CH62	CH62	CH62
CH63	CH63	CH63
CH64	CH64	CH64
CH65	CH65	CH65
CH66	CH66	CH66
CH67	CH67	CH67
CH68	CH68	CH68
CH69	CH69	CH69
CH70	CH70	CH70
CH71	CH71	CH71
CH72	CH72	CH72
CH73	CH73	CH73
CH74	CH74	CH74
CH75	CH75	CH75
CH76	CH76	CH76
CH77	CH77	CH77
CH78	CH78	CH78
CH79	CH79	CH79
CH80	CH80	CH80
CH81	CH81	CH81
CH82	CH82	CH82
CH83	CH83	CH83
CH84	CH84	CH84
CH85	CH85	CH85
CH86	CH86	CH86
CH87	CH87	CH87
CH88	CH88	CH88
CH89	CH89	CH89
CH90	CH90	CH90
CH91	CH91	CH91
CH92	CH92	CH92
CH93	CH93	CH93
CH94	CH94	CH94
CH95	CH95	CH95
CH96	CH96	CH96

## Initial Output Channel Names

Output Channel ID	Short Name	Long Name
BUS1	BUS1	BUS1
BUS2	BUS2	BUS2
BUS3	BUS3	BUS3
BUS4	BUS4	BUS4
BUS5	BUS5	BUS5
BUS6	BUS6	BUS6
BUS7	BUS7	BUS7
BUS8	BUS8	BUS8
AUX1	AUX1	AUX1
AUX2	AUX2	AUX2
AUX3	AUX3	AUX3
AUX4	AUX4	AUX4
AUX5	AUX5	AUX5
AUX6	AUX6	AUX6
AUX7	AUX7	AUX7
AUX8	AUX8	AUX8
AUX9	AUX9	AUX9
AX10	AX10	AUX10
AX11	AX11	AUX11
AX12	AX12	AUX12
MTX1	MTX1	MATRIX1
MTX2	MTX2	MATRIX2
MTX3	MTX3	MATRIX3
MTX4	MTX4	MATRIX4
ST	ST	STEREO

## Initial Input Port Names

Port	PORT ID	Short Name	Long Name
AD1	AD01	AD01	AD IN 1
AD2	AD02	AD02	AD IN 2
AD3	AD03	AD03	AD IN 3
AD4	AD04	AD04	AD IN 4
AD5	AD05	AD05	AD IN 5
AD6	AD06	AD06	AD IN 6
AD7	AD07	AD07	AD IN 7
AD8	AD08	AD08	AD IN 8
AD9	AD09	AD09	AD IN 9
AD10	AD10	AD10	AD IN 10
AD11	AD11	AD11	AD IN 11
AD12	AD12	AD12	AD IN 12
AD13	AD13	AD13	AD IN 13
AD14	AD14	AD14	AD IN 14
AD15	AD15	AD15	AD IN 15
AD16	AD16	AD16	AD IN 16
AD17	AD17	AD17	AD IN 17
AD18	AD18	AD18	AD IN 18
AD19	AD19	AD19	AD IN 19
AD20	AD20	AD20	AD IN 20
AD21	AD21	AD21	AD IN 21
AD22	AD22	AD22	AD IN 22
AD23	AD23	AD23	AD IN 23
AD24	AD24	AD24	AD IN 24
SLOT1-01	S1-1	S1-1	Slot1 CH1 IN
SLOT1-02	S1-2	S1-2	Slot1 CH2 IN
SLOT1-03	S1-3	S1-3	Slot1 CH3 IN
SLOT1-04	S1-4	S1-4	Slot1 CH4 IN
SLOT1-05	S1-5	S1-5	Slot1 CH5 IN
SLOT1-06	S1-6	S1-6	Slot1 CH6 IN
SLOT1-07	S1-7	S1-7	Slot1 CH7 IN
SLOT1-08	S1-8	S1-8	Slot1 CH8 IN
SLOT1-09	S1-9	S1-9	Slot1 CH9 IN
SLOT1-10	S110	S110	Slot1 CH10 IN
SLOT1-11	S111	S111	Slot1 CH11 IN
SLOT1-12	S112	S112	Slot1 CH12 IN
SLOT1-13	S113	S113	Slot1 CH13 IN
SLOT1-14	S114	S114	Slot1 CH14 IN
SLOT1-15	S115	S115	Slot1 CH15 IN
SLOT1-16	S116	S116	Slot1 CH16 IN
SLOT2-01	S2-1	S2-1	Slot2 CH1 IN
SLOT2-02	S2-2	S2-2	Slot2 CH2 IN
SLOT2-03	S2-3	S2-3	Slot2 CH3 IN
SLOT2-04	S2-4	S2-4	Slot2 CH4 IN
SLOT2-05	S2-5	S2-5	Slot2 CH5 IN
SLOT2-06	S2-6	S2-6	Slot2 CH6 IN
SLOT2-07	S2-7	S2-7	Slot2 CH7 IN
SLOT2-08	S2-8	S2-8	Slot2 CH8 IN
SLOT2-09	S2-9	S2-9	Slot2 CH9 IN
SLOT2-10	S210	S210	Slot2 CH10 IN
SLOT2-11	S211	S211	Slot2 CH11 IN
SLOT2-12	S212	S212	Slot2 CH12 IN
SLOT2-13	S213	S213	Slot2 CH13 IN
SLOT2-14	S214	S214	Slot2 CH14 IN
SLOT2-15	S215	S215	Slot2 CH15 IN
SLOT2-16	S216	S216	Slot2 CH16 IN
SLOT3-01	S3-1	S3-1	Slot3 CH1 IN
SLOT3-02	S3-2	S3-2	Slot3 CH2 IN
SLOT3-03	S3-3	S3-3	Slot3 CH3 IN
SLOT3-04	S3-4	S3-4	Slot3 CH4 IN
SLOT3-05	S3-5	S3-5	Slot3 CH5 IN
SLOT3-06	S3-6	S3-6	Slot3 CH6 IN
SLOT3-07	S3-7	S3-7	Slot3 CH7 IN
SLOT3-08	S3-8	S3-8	Slot3 CH8 IN
SLOT3-09	S3-9	S3-9	Slot3 CH9 IN

Port	PORT ID	Short Name	Long Name
SLOT3-10	S310	S310	Slot3 CH10 IN
SLOT3-11	S311	S311	Slot3 CH11 IN
SLOT3-12	S312	S312	Slot3 CH12 IN
SLOT3-13	S313	S313	Slot3 CH13 IN
SLOT3-14	S314	S314	Slot3 CH14 IN
SLOT3-15	S315	S315	Slot3 CH15 IN
SLOT3-16	S316	S316	Slot3 CH16 IN
SLOT4-01	S4-1	S4-1	Slot4 CH1 IN
SLOT4-02	S4-2	S4-2	Slot4 CH2 IN
SLOT4-03	S4-3	S4-3	Slot4 CH3 IN
SLOT4-04	S4-4	S4-4	Slot4 CH4 IN
SLOT4-05	S4-5	S4-5	Slot4 CH5 IN
SLOT4-06	S4-6	S4-6	Slot4 CH6 IN
SLOT4-07	S4-7	S4-7	Slot4 CH7 IN
SLOT4-08	S4-8	S4-8	Slot4 CH8 IN
SLOT4-09	S4-9	S4-9	Slot4 CH9 IN
SLOT4-10	S410	S410	Slot4 CH10 IN
SLOT4-11	S411	S411	Slot4 CH11 IN
SLOT4-12	S412	S412	Slot4 CH12 IN
SLOT4-13	S413	S413	Slot4 CH13 IN
SLOT4-14	S414	S414	Slot4 CH14 IN
SLOT4-15	S415	S415	Slot4 CH15 IN
SLOT4-16	S416	S416	Slot4 CH16 IN
SLOT5-01	S5-1	S5-1	Slot5 CH1 IN
SLOT5-02	S5-2	S5-2	Slot5 CH2 IN
SLOT5-03	S5-3	S5-3	Slot5 CH3 IN
SLOT5-04	S5-4	S5-4	Slot5 CH4 IN
SLOT5-05	S5-5	S5-5	Slot5 CH5 IN
SLOT5-06	S5-6	S5-6	Slot5 CH6 IN
SLOT5-07	S5-7	S5-7	Slot5 CH7 IN
SLOT5-08	S5-8	S5-8	Slot5 CH8 IN
SLOT5-09	S5-9	S5-9	Slot5 CH9 IN
SLOT5-10	S510	S510	Slot5 CH10 IN
SLOT5-11	S511	S511	Slot5 CH11 IN
SLOT5-12	S512	S512	Slot5 CH12 IN
SLOT5-13	S513	S513	Slot5 CH13 IN
SLOT5-14	S514	S514	Slot5 CH14 IN
SLOT5-15	S515	S515	Slot5 CH15 IN
SLOT5-16	S516	S516	Slot5 CH16 IN
SLOT6-01	S6-1	S6-1	Slot6 CH1 IN
SLOT6-02	S6-2	S6-2	Slot6 CH2 IN
SLOT6-03	S6-3	S6-3	Slot6 CH3 IN
SLOT6-04	S6-4	S6-4	Slot6 CH4 IN
SLOT6-05	S6-5	S6-5	Slot6 CH5 IN
SLOT6-06	S6-6	S6-6	Slot6 CH6 IN
SLOT6-07	S6-7	S6-7	Slot6 CH7 IN
SLOT6-08	S6-8	S6-8	Slot6 CH8 IN
SLOT6-09	S6-9	S6-9	Slot6 CH9 IN
SLOT6-10	S610	S610	Slot6 CH10 IN
SLOT6-11	S611	S611	Slot6 CH11 IN
SLOT6-12	S612	S612	Slot6 CH12 IN
SLOT6-13	S613	S613	Slot6 CH13 IN
SLOT6-14	S614	S614	Slot6 CH14 IN
SLOT6-15	S615	S615	Slot6 CH15 IN
SLOT6-16	S616	S616	Slot6 CH16 IN
2TD1L	2TD1L	2D1L	2TR IN Dig.1 L
2TD1R	2TD1R	2D1R	2TR IN Dig.1 R
2TD2L	2TD2L	2D2L	2TR IN Dig.2 L
2TD2R	2TD2R	2D2R	2TR IN Dig.2 R
2TD3L	2TD3L	2D3L	2TR IN Dig.3 L
2TD3R	2TD3R	2D3R	2TR IN Dig.3 R
2TA1L	2TA1L	2A1L	2TR IN Analog1 L
2TA1R	2TA1R	2A1R	2TR IN Analog1 R
2TA2L	2TA2L	2A2L	2TR IN Analog2 L
2TA2R	2TA2R	2A2R	2TR IN Analog2 R

## Initial Output Port Names

Port	Port ID	Short Name	Long Name
SLOT1-01	S1-01	S101	Slot1 CH1 OUT
SLOT1-02	S1-02	S102	Slot1 CH2 OUT
SLOT1-03	S1-03	S103	Slot1 CH3 OUT
SLOT1-04	S1-04	S104	Slot1 CH4 OUT
SLOT1-05	S1-05	S105	Slot1 CH5 OUT
SLOT1-06	S1-06	S106	Slot1 CH6 OUT
SLOT1-07	S1-07	S107	Slot1 CH7 OUT
SLOT1-08	S1-08	S108	Slot1 CH8 OUT
SLOT1-09	S1-09	S109	Slot1 CH9 OUT
SLOT1-10	S1-10	S110	Slot1 CH10 OUT
SLOT1-11	S1-11	S111	Slot1 CH11 OUT
SLOT1-12	S1-12	S112	Slot1 CH12 OUT
SLOT1-13	S1-13	S113	Slot1 CH13 OUT
SLOT1-14	S1-14	S114	Slot1 CH14 OUT
SLOT1-15	S1-15	S115	Slot1 CH15 OUT
SLOT1-16	S1-16	S116	Slot1 CH16 OUT
SLOT2-01	S2-01	S201	Slot2 CH1 OUT
SLOT2-02	S2-02	S202	Slot2 CH2 OUT
SLOT2-03	S2-03	S203	Slot2 CH3 OUT
SLOT2-04	S2-04	S204	Slot2 CH4 OUT
SLOT2-05	S2-05	S205	Slot2 CH5 OUT
SLOT2-06	S2-06	S206	Slot2 CH6 OUT
SLOT2-07	S2-07	S207	Slot2 CH7 OUT
SLOT2-08	S2-08	S208	Slot2 CH8 OUT
SLOT2-09	S2-09	S209	Slot2 CH9 OUT
SLOT2-10	S2-10	S210	Slot2 CH10 OUT
SLOT2-11	S2-11	S211	Slot2 CH11 OUT
SLOT2-12	S2-12	S212	Slot2 CH12 OUT
SLOT2-13	S2-13	S213	Slot2 CH13 OUT
SLOT2-14	S2-14	S214	Slot2 CH14 OUT
SLOT2-15	S2-15	S215	Slot2 CH15 OUT
SLOT2-16	S2-16	S216	Slot2 CH16 OUT
SLOT3-01	S3-01	S301	Slot3 CH1 OUT
SLOT3-02	S3-02	S302	Slot3 CH2 OUT
SLOT3-03	S3-03	S303	Slot3 CH3 OUT
SLOT3-04	S3-04	S304	Slot3 CH4 OUT
SLOT3-05	S3-05	S305	Slot3 CH5 OUT
SLOT3-06	S3-06	S306	Slot3 CH6 OUT
SLOT3-07	S3-07	S307	Slot3 CH7 OUT
SLOT3-08	S3-08	S308	Slot3 CH8 OUT
SLOT3-09	S3-09	S309	Slot3 CH9 OUT
SLOT3-10	S3-10	S310	Slot3 CH10 OUT
SLOT3-11	S3-11	S311	Slot3 CH11 OUT
SLOT3-12	S3-12	S312	Slot3 CH12 OUT
SLOT3-13	S3-13	S313	Slot3 CH13 OUT
SLOT3-14	S3-14	S314	Slot3 CH14 OUT
SLOT3-15	S3-15	S315	Slot3 CH15 OUT
SLOT3-16	S3-16	S316	Slot3 CH16 OUT
SLOT4-01	S4-01	S401	Slot4 CH1 OUT
SLOT4-02	S4-02	S402	Slot4 CH2 OUT
SLOT4-03	S4-03	S403	Slot4 CH3 OUT
SLOT4-04	S4-04	S404	Slot4 CH4 OUT
SLOT4-05	S4-05	S405	Slot4 CH5 OUT
SLOT4-06	S4-06	S406	Slot4 CH6 OUT
SLOT4-07	S4-07	S407	Slot4 CH7 OUT
SLOT4-08	S4-08	S408	Slot4 CH8 OUT
SLOT4-09	S4-09	S409	Slot4 CH9 OUT

Port	Port ID	Short Name	Long Name
SLOT4-10	S4-10	S410	Slot4 CH10 OUT
SLOT4-11	S4-11	S411	Slot4 CH11 OUT
SLOT4-12	S4-12	S412	Slot4 CH12 OUT
SLOT4-13	S4-13	S413	Slot4 CH13 OUT
SLOT4-14	S4-14	S414	Slot4 CH14 OUT
SLOT4-15	S4-15	S415	Slot4 CH15 OUT
SLOT4-16	S4-16	S416	Slot4 CH16 OUT
SLOT5-01	S5-01	S501	Slot5 CH1 OUT
SLOT5-02	S5-02	S502	Slot5 CH2 OUT
SLOT5-03	S5-03	S503	Slot5 CH3 OUT
SLOT5-04	S5-04	S504	Slot5 CH4 OUT
SLOT5-05	S5-05	S505	Slot5 CH5 OUT
SLOT5-06	S5-06	S506	Slot5 CH6 OUT
SLOT5-07	S5-07	S507	Slot5 CH7 OUT
SLOT5-08	S5-08	S508	Slot5 CH8 OUT
SLOT5-09	S5-09	S509	Slot5 CH9 OUT
SLOT5-10	S5-10	S510	Slot5 CH10 OUT
SLOT5-11	S5-11	S511	Slot5 CH11 OUT
SLOT5-12	S5-12	S512	Slot5 CH12 OUT
SLOT5-13	S5-13	S513	Slot5 CH13 OUT
SLOT5-14	S5-14	S514	Slot5 CH14 OUT
SLOT5-15	S5-15	S515	Slot5 CH15 OUT
SLOT5-16	S5-16	S516	Slot5 CH16 OUT
SLOT6-01	S6-01	S601	Slot6 CH1 OUT
SLOT6-02	S6-02	S602	Slot6 CH2 OUT
SLOT6-03	S6-03	S603	Slot6 CH3 OUT
SLOT6-04	S6-04	S604	Slot6 CH4 OUT
SLOT6-05	S6-05	S605	Slot6 CH5 OUT
SLOT6-06	S6-06	S606	Slot6 CH6 OUT
SLOT6-07	S6-07	S607	Slot6 CH7 OUT
SLOT6-08	S6-08	S608	Slot6 CH8 OUT
SLOT6-09	S6-09	S609	Slot6 CH9 OUT
SLOT6-10	S6-10	S610	Slot6 CH10 OUT
SLOT6-11	S6-11	S611	Slot6 CH11 OUT
SLOT6-12	S6-12	S612	Slot6 CH12 OUT
SLOT6-13	S6-13	S613	Slot6 CH13 OUT
SLOT6-14	S6-14	S614	Slot6 CH14 OUT
SLOT6-15	S6-15	S615	Slot6 CH15 OUT
SLOT6-16	S6-16	S616	Slot6 CH16 OUT
OMNI1	OMNI1	OMN1	OMNI OUT 1
OMNI2	OMNI2	OMN2	OMNI OUT 2
OMNI3	OMNI3	OMN3	OMNI OUT 3
OMNI4	OMNI4	OMN4	OMNI OUT 4
OMNI5	OMNI5	OMN5	OMNI OUT 5
OMNI6	OMNI6	OMN6	OMNI OUT 6
OMNI7	OMNI7	OMN7	OMNI OUT 7
OMNI8	OMNI8	OMN8	OMNI OUT 8
2TD1L	2TD1L	2D1L	2TR OUT Dig. 1L
2TD1R	2TD1R	2D1R	2TR OUT Dig. 1R
2TD2L	2TD2L	2D2L	2TR OUT Dig. 2L
2TD2R	2TD2R	2D2R	2TR OUT Dig. 2R
2TD3L	2TD3L	2D3L	2TR OUT Dig. 3L
2TD3R	2TD3R	2D3R	2TR OUT Dig. 3R

## GPI Trigger Source & Target List

### INPUT

#	Target	#	Target	#	Target	#	Target
0	NO ASSIGN	55	CH15 ON	110	CH70 ON	165	CH4 ON UNLATCH
1	TALKBACK	56	CH16 ON	111	CH71 ON	166	CH5 ON UNLATCH
2	SLATE	57	CH17 ON	112	CH72 ON	167	CH6 ON UNLATCH
3	DIMMER	58	CH18 ON	113	CH73 ON	168	CH7 ON UNLATCH
4	MONO	59	CH19 ON	114	CH74 ON	169	CH8 ON UNLATCH
5	SMALL	60	CH20 ON	115	CH75 ON	170	CH9 ON UNLATCH
6	SR BUS	61	CH21 ON	116	CH76 ON	171	CH10 ON UNLATCH
7	SR ASSIGN1	62	CH22 ON	117	CH77 ON	172	CH11 ON UNLATCH
8	SR ASSIGN2	63	CH23 ON	118	CH78 ON	173	CH12 ON UNLATCH
9	CR STEREO	64	CH24 ON	119	CH79 ON	174	CH13 ON UNLATCH
10	CR 2TRD1	65	CH25 ON	120	CH80 ON	175	CH14 ON UNLATCH
11	CR 2TRD2	66	CH26 ON	121	CH81 ON	176	CH15 ON UNLATCH
12	CR 2TRD3	67	CH27 ON	122	CH82 ON	177	CH16 ON UNLATCH
13	CR 2TRA1	68	CH28 ON	123	CH83 ON	178	CH17 ON UNLATCH
14	CR 2TRA2	69	CH29 ON	124	CH84 ON	179	CH18 ON UNLATCH
15	CR ASSIGN1	70	CH30 ON	125	CH85 ON	180	CH19 ON UNLATCH
16	CR ASSIGN2	71	CH31 ON	126	CH86 ON	181	CH20 ON UNLATCH
17	SM C-R	72	CH32 ON	127	CH87 ON	182	CH21 ON UNLATCH
18	SM STEREO	73	CH33 ON	128	CH88 ON	183	CH22 ON UNLATCH
19	SM AUX11	74	CH34 ON	129	CH89 ON	184	CH23 ON UNLATCH
20	SM AUX12	75	CH35 ON	130	CH90 ON	185	CH24 ON UNLATCH
21	TALKBACK UNLATCH	76	CH36 ON	131	CH91 ON	186	CH25 ON UNLATCH
22	SLATE UNLATCH	77	CH37 ON	132	CH92 ON	187	CH26 ON UNLATCH
23	DIMMER UNLATCH	78	CH38 ON	133	CH93 ON	188	CH27 ON UNLATCH
24	MONO UNLATCH	79	CH39 ON	134	CH94 ON	189	CH28 ON UNLATCH
25	SMALL UNLATCH	80	CH40 ON	135	CH95 ON	190	CH29 ON UNLATCH
26	SR BUS UNLATCH	81	CH41 ON	136	CH96 ON	191	CH30 ON UNLATCH
27	SR ASGN1 UNLATCH	82	CH42 ON	137	BUS1 ON	192	CH31 ON UNLATCH
28	SR ASGN2 UNLATCH	83	CH43 ON	138	BUS2 ON	193	CH32 ON UNLATCH
29	CR ST UNLATCH	84	CH44 ON	139	BUS3 ON	194	CH33 ON UNLATCH
30	CR 2TRD1 UNLATCH	85	CH45 ON	140	BUS4 ON	195	CH34 ON UNLATCH
31	CR 2TRD2 UNLATCH	86	CH46 ON	141	BUS5 ON	196	CH35 ON UNLATCH
32	CR 2TRD3 UNLATCH	87	CH47 ON	142	BUS6 ON	197	CH36 ON UNLATCH
33	CR 2TRA1 UNLATCH	88	CH48 ON	143	BUS7 ON	198	CH37 ON UNLATCH
34	CR 2TRA2 UNLATCH	89	CH49 ON	144	BUS8 ON	199	CH38 ON UNLATCH
35	CR ASGN1 UNLATCH	90	CH50 ON	145	AUX1 ON	200	CH39 ON UNLATCH
36	CR ASGN2 UNLATCH	91	CH51 ON	146	AUX2 ON	201	CH40 ON UNLATCH
37	SD C-R UNLATCH	92	CH52 ON	147	AUX3 ON	202	CH41 ON UNLATCH
38	SD ST UNLATCH	93	CH53 ON	148	AUX4 ON	203	CH42 ON UNLATCH
39	SD AUX11 UNLATCH	94	CH54 ON	149	AUX5 ON	204	CH43 ON UNLATCH
40	SD AUX12 UNLATCH	95	CH55 ON	150	AUX6 ON	205	CH44 ON UNLATCH
41	CH1 ON	96	CH56 ON	151	AUX7 ON	206	CH45 ON UNLATCH
42	CH2 ON	97	CH57 ON	152	AUX8 ON	207	CH46 ON UNLATCH
43	CH3 ON	98	CH58 ON	153	AUX9 ON	208	CH47 ON UNLATCH
44	CH4 ON	99	CH59 ON	154	AUX10 ON	209	CH48 ON UNLATCH
45	CH5 ON	100	CH60 ON	155	AUX11 ON	210	CH49 ON UNLATCH
46	CH6 ON	101	CH61 ON	156	AUX12 ON	211	CH50 ON UNLATCH
47	CH7 ON	102	CH62 ON	157	MATRIX1 ON	212	CH51 ON UNLATCH
48	CH8 ON	103	CH63 ON	158	MATRIX2 ON	213	CH52 ON UNLATCH
49	CH9 ON	104	CH64 ON	159	MATRIX3 ON	214	CH53 ON UNLATCH
50	CH10 ON	105	CH65 ON	160	MATRIX4 ON	215	CH54 ON UNLATCH
51	CH11 ON	106	CH66 ON	161	STEREO ON	216	CH55 ON UNLATCH
52	CH12 ON	107	CH67 ON	162	CH1 ON UNLATCH	217	CH56 ON UNLATCH
53	CH13 ON	108	CH68 ON	163	CH2 ON UNLATCH	218	CH57 ON UNLATCH
54	CH14 ON	109	CH69 ON	164	CH3 ON UNLATCH	219	CH58 ON UNLATCH

#	Target
220	CH59 ON UNLATCH
221	CH60 ON UNLATCH
222	CH61 ON UNLATCH
223	CH62 ON UNLATCH
224	CH63 ON UNLATCH
225	CH64 ON UNLATCH
226	CH65 ON UNLATCH
227	CH66 ON UNLATCH
228	CH67 ON UNLATCH
229	CH68 ON UNLATCH
230	CH69 ON UNLATCH
231	CH70 ON UNLATCH
232	CH71 ON UNLATCH
233	CH72 ON UNLATCH
234	CH73 ON UNLATCH
235	CH74 ON UNLATCH
236	CH75 ON UNLATCH
237	CH76 ON UNLATCH
238	CH77 ON UNLATCH
239	CH78 ON UNLATCH
240	CH79 ON UNLATCH
241	CH80 ON UNLATCH
242	CH81 ON UNLATCH
243	CH82 ON UNLATCH
244	CH83 ON UNLATCH
245	CH84 ON UNLATCH
246	CH85 ON UNLATCH
247	CH86 ON UNLATCH
248	CH87 ON UNLATCH
249	CH88 ON UNLATCH
250	CH89 ON UNLATCH
251	CH90 ON UNLATCH
252	CH91 ON UNLATCH
253	CH92 ON UNLATCH
254	CH93 ON UNLATCH
255	CH94 ON UNLATCH
256	CH95 ON UNLATCH
257	CH96 ON UNLATCH
258	BUS1 ON UNLATCH
259	BUS2 ON UNLATCH
260	BUS3 ON UNLATCH
261	BUS4 ON UNLATCH
262	BUS5 ON UNLATCH
263	BUS6 ON UNLATCH
264	BUS7 ON UNLATCH
265	BUS8 ON UNLATCH
266	AUX1 ON UNLATCH
267	AUX2 ON UNLATCH
268	AUX3 ON UNLATCH
269	AUX4 ON UNLATCH
270	AUX5 ON UNLATCH
271	AUX6 ON UNLATCH
272	AUX7 ON UNLATCH
273	AUX8 ON UNLATCH
274	AUX9 ON UNLATCH
275	AUX10 ON UNLATCH
276	AUX11 ON UNLATCH
277	AUX12 ON UNLATCH
278	MTX1 ON UNLATCH

#	Target
279	MTX2 ON UNLATCH
280	MTX3 ON UNLATCH
281	MTX4 ON UNLATCH
282	ST ON UNLATCH
283	UDEF1
284	UDEF2
285	UDEF3
286	UDEF4
287	UDEF5
288	UDEF6
289	UDEF7
290	UDEF8
291	UDEF9
292	UDEF10
293	UDEF11
294	UDEF12
295	UDEF13
296	UDEF14
297	UDEF15
298	UDEF16

## OUTPUT

#	Target
0	NO ASSIGN
1	CH1 FADER ON
2	CH2 FADER ON
3	CH3 FADER ON
4	CH4 FADER ON
5	CH5 FADER ON
6	CH6 FADER ON
7	CH7 FADER ON
8	CH8 FADER ON
9	CH9 FADER ON
10	CH10 FADER ON
11	CH11 FADER ON
12	CH12 FADER ON
13	CH13 FADER ON
14	CH14 FADER ON
15	CH15 FADER ON
16	CH16 FADER ON
17	CH17 FADER ON
18	CH18 FADER ON
19	CH19 FADER ON
20	CH20 FADER ON
21	CH21 FADER ON
22	CH22 FADER ON
23	CH23 FADER ON
24	CH24 FADER ON
25	CH25 FADER ON
26	CH26 FADER ON
27	CH27 FADER ON
28	CH28 FADER ON
29	CH29 FADER ON
30	CH30 FADER ON
31	CH31 FADER ON
32	CH32 FADER ON
33	CH33 FADER ON
34	CH34 FADER ON
35	CH35 FADER ON
36	CH36 FADER ON
37	CH37 FADER ON
38	CH38 FADER ON
39	CH39 FADER ON
40	CH40 FADER ON
41	CH41 FADER ON
42	CH42 FADER ON
43	CH43 FADER ON
44	CH44 FADER ON
45	CH45 FADER ON
46	CH46 FADER ON
47	CH47 FADER ON
48	CH48 FADER ON
49	CH49 FADER ON
50	CH50 FADER ON
51	CH51 FADER ON
52	CH52 FADER ON
53	CH53 FADER ON
54	CH54 FADER ON
55	CH55 FADER ON
56	CH56 FADER ON
57	CH57 FADER ON

#	Target
58	CH58 FADER ON
59	CH59 FADER ON
60	CH60 FADER ON
61	CH61 FADER ON
62	CH62 FADER ON
63	CH63 FADER ON
64	CH64 FADER ON
65	CH65 FADER ON
66	CH66 FADER ON
67	CH67 FADER ON
68	CH68 FADER ON
69	CH69 FADER ON
70	CH70 FADER ON
71	CH71 FADER ON
72	CH72 FADER ON
73	CH73 FADER ON
74	CH74 FADER ON
75	CH75 FADER ON
76	CH76 FADER ON
77	CH77 FADER ON
78	CH78 FADER ON
79	CH79 FADER ON
80	CH80 FADER ON
81	CH81 FADER ON
82	CH82 FADER ON
83	CH83 FADER ON
84	CH84 FADER ON
85	CH85 FADER ON
86	CH86 FADER ON
87	CH87 FADER ON
88	CH88 FADER ON
89	CH89 FADER ON
90	CH90 FADER ON
91	CH91 FADER ON
92	CH92 FADER ON
93	CH93 FADER ON
94	CH94 FADER ON
95	CH95 FADER ON
96	CH96 FADER ON
97	BUS1 FADER ON
98	BUS2 FADER ON
99	BUS3 FADER ON
100	BUS4 FADER ON
101	BUS5 FADER ON
102	BUS6 FADER ON
103	BUS7 FADER ON
104	BUS8 FADER ON
105	AUX1 FADER ON
106	AUX2 FADER ON
107	AUX3 FADER ON
108	AUX4 FADER ON
109	AUX5 FADER ON
110	AUX6 FADER ON
111	AUX7 FADER ON
112	AUX8 FADER ON
113	AUX9 FADER ON
114	AUX10 FADER ON
115	AUX11 FADER ON

#	Target
116	AUX12 FADER ON
117	MATRIX1 FADER ON
118	MATRIX2 FADER ON
119	MATRIX3 FADER ON
120	MATRIX4 FADER ON
121	STEREO FADER ON
122	CH1 FADER OFF
123	CH2 FADER OFF
124	CH3 FADER OFF
125	CH4 FADER OFF
126	CH5 FADER OFF
127	CH6 FADER OFF
128	CH7 FADER OFF
129	CH8 FADER OFF
130	CH9 FADER OFF
131	CH10 FADER OFF
132	CH11 FADER OFF
133	CH12 FADER OFF
134	CH13 FADER OFF
135	CH14 FADER OFF
136	CH15 FADER OFF
137	CH16 FADER OFF
138	CH17 FADER OFF
139	CH18 FADER OFF
140	CH19 FADER OFF
141	CH20 FADER OFF
142	CH21 FADER OFF
143	CH22 FADER OFF
144	CH23 FADER OFF
145	CH24 FADER OFF
146	CH25 FADER OFF
147	CH26 FADER OFF
148	CH27 FADER OFF
149	CH28 FADER OFF
150	CH29 FADER OFF
151	CH30 FADER OFF
152	CH31 FADER OFF
153	CH32 FADER OFF
154	CH33 FADER OFF
155	CH34 FADER OFF
156	CH35 FADER OFF
157	CH36 FADER OFF
158	CH37 FADER OFF
159	CH38 FADER OFF
160	CH39 FADER OFF
161	CH40 FADER OFF
162	CH41 FADER OFF
163	CH42 FADER OFF
164	CH43 FADER OFF
165	CH44 FADER OFF
166	CH45 FADER OFF
167	CH46 FADER OFF
168	CH47 FADER OFF
169	CH48 FADER OFF
170	CH49 FADER OFF
171	CH50 FADER OFF
172	CH51 FADER OFF
173	CH52 FADER OFF

#	Target
174	CH53 FADER OFF
175	CH54 FADER OFF
176	CH55 FADER OFF
177	CH56 FADER OFF
178	CH57 FADER OFF
179	CH58 FADER OFF
180	CH59 FADER OFF
181	CH60 FADER OFF
182	CH61 FADER OFF
183	CH62 FADER OFF
184	CH63 FADER OFF
185	CH64 FADER OFF
186	CH65 FADER OFF
187	CH66 FADER OFF
188	CH67 FADER OFF
189	CH68 FADER OFF
190	CH69 FADER OFF
191	CH70 FADER OFF
192	CH71 FADER OFF
193	CH72 FADER OFF
194	CH73 FADER OFF
195	CH74 FADER OFF
196	CH75 FADER OFF
197	CH76 FADER OFF
198	CH77 FADER OFF
199	CH78 FADER OFF
200	CH79 FADER OFF
201	CH80 FADER OFF
202	CH81 FADER OFF
203	CH82 FADER OFF
204	CH83 FADER OFF
205	CH84 FADER OFF
206	CH85 FADER OFF
207	CH86 FADER OFF
208	CH87 FADER OFF
209	CH88 FADER OFF
210	CH89 FADER OFF
211	CH90 FADER OFF
212	CH91 FADER OFF
213	CH92 FADER OFF
214	CH93 FADER OFF
215	CH94 FADER OFF
216	CH95 FADER OFF
217	CH96 FADER OFF
218	BUS1 FADER OFF
219	BUS2 FADER OFF
220	BUS3 FADER OFF
221	BUS4 FADER OFF
222	BUS5 FADER OFF
223	BUS6 FADER OFF
224	BUS7 FADER OFF
225	BUS8 FADER OFF
226	AUX1 FADER OFF
227	AUX2 FADER OFF
228	AUX3 FADER OFF
229	AUX4 FADER OFF
230	AUX5 FADER OFF
231	AUX6 FADER OFF



#	Target
232	AUX7 FADER OFF
233	AUX8 FADER OFF
234	AUX9 FADER OFF
235	AUX10 FADER OFF
236	AUX11 FADER OFF
237	AUX12 FADER OFF
238	MATRIX1 FADER OFF
239	MATRIX2 FADER OFF
240	MATRIX3 FADER OFF
241	MATRIX4 FADER OFF
242	STEREO FADER OFF
243	CH1 FADER TALLY
244	CH2 FADER TALLY
245	CH3 FADER TALLY
246	CH4 FADER TALLY
247	CH5 FADER TALLY
248	CH6 FADER TALLY
249	CH7 FADER TALLY
250	CH8 FADER TALLY
251	CH9 FADER TALLY
252	CH10 FADER TALLY
253	CH11 FADER TALLY
254	CH12 FADER TALLY
255	CH13 FADER TALLY
256	CH14 FADER TALLY
257	CH15 FADER TALLY
258	CH16 FADER TALLY
259	CH17 FADER TALLY
260	CH18 FADER TALLY
261	CH19 FADER TALLY
262	CH20 FADER TALLY
263	CH21 FADER TALLY
264	CH22 FADER TALLY
265	CH23 FADER TALLY
266	CH24 FADER TALLY
267	CH25 FADER TALLY
268	CH26 FADER TALLY
269	CH27 FADER TALLY
270	CH28 FADER TALLY
271	CH29 FADER TALLY
272	CH30 FADER TALLY
273	CH31 FADER TALLY
274	CH32 FADER TALLY
275	CH33 FADER TALLY
276	CH34 FADER TALLY
277	CH35 FADER TALLY
278	CH36 FADER TALLY
279	CH37 FADER TALLY
280	CH38 FADER TALLY
281	CH39 FADER TALLY
282	CH40 FADER TALLY
283	CH41 FADER TALLY
284	CH42 FADER TALLY
285	CH43 FADER TALLY
286	CH44 FADER TALLY
287	CH45 FADER TALLY
288	CH46 FADER TALLY
289	CH47 FADER TALLY
290	CH48 FADER TALLY

#	Target
291	CH49 FADER TALLY
292	CH50 FADER TALLY
293	CH51 FADER TALLY
294	CH52 FADER TALLY
295	CH53 FADER TALLY
296	CH54 FADER TALLY
297	CH55 FADER TALLY
298	CH56 FADER TALLY
299	CH57 FADER TALLY
300	CH58 FADER TALLY
301	CH59 FADER TALLY
302	CH60 FADER TALLY
303	CH61 FADER TALLY
304	CH62 FADER TALLY
305	CH63 FADER TALLY
306	CH64 FADER TALLY
307	CH65 FADER TALLY
308	CH66 FADER TALLY
309	CH67 FADER TALLY
310	CH68 FADER TALLY
311	CH69 FADER TALLY
312	CH70 FADER TALLY
313	CH71 FADER TALLY
314	CH72 FADER TALLY
315	CH73 FADER TALLY
316	CH74 FADER TALLY
317	CH75 FADER TALLY
318	CH76 FADER TALLY
319	CH77 FADER TALLY
320	CH78 FADER TALLY
321	CH79 FADER TALLY
322	CH80 FADER TALLY
323	CH81 FADER TALLY
324	CH82 FADER TALLY
325	CH83 FADER TALLY
326	CH84 FADER TALLY
327	CH85 FADER TALLY
328	CH86 FADER TALLY
329	CH87 FADER TALLY
330	CH88 FADER TALLY
331	CH89 FADER TALLY
332	CH90 FADER TALLY
333	CH91 FADER TALLY
334	CH92 FADER TALLY
335	CH93 FADER TALLY
336	CH94 FADER TALLY
337	CH95 FADER TALLY
338	CH96 FADER TALLY
339	BUS1 FADER TALLY
340	BUS2 FADER TALLY
341	BUS3 FADER TALLY
342	BUS4 FADER TALLY
343	BUS5 FADER TALLY
344	BUS6 FADER TALLY
345	BUS7 FADER TALLY
346	BUS8 FADER TALLY
347	AUX1 FADER TALLY
348	AUX2 FADER TALLY
349	AUX3 FADER TALLY

#	Target
350	AUX4 FADER TALLY
351	AUX5 FADER TALLY
352	AUX6 FADER TALLY
353	AUX7 FADER TALLY
354	AUX8 FADER TALLY
355	AUX9 FADER TALLY
356	AX10 FADER TALLY
357	AX11 FADER TALLY
358	AX12 FADER TALLY
359	MTX1 FADER TALLY
360	MTX2 FADER TALLY
361	MTX3 FADER TALLY
362	MTX4 FADER TALLY
363	ST FADER TALLY
364	UDEF1 LATCH
365	UDEF2 LATCH
366	UDEF3 LATCH
367	UDEF4 LATCH
368	UDEF5 LATCH
369	UDEF6 LATCH
370	UDEF7 LATCH
371	UDEF8 LATCH
372	UDEF9 LATCH
373	UDEF10 LATCH
374	UDEF11 LATCH
375	UDEF12 LATCH
376	UDEF13 LATCH
377	UDEF14 LATCH
378	UDEF15 LATCH
379	UDEF16 LATCH
380	UDEF1 UNLATCH
381	UDEF2 UNLATCH
382	UDEF3 UNLATCH
383	UDEF4 UNLATCH
384	UDEF5 UNLATCH
385	UDEF6 UNLATCH
386	UDEF7 UNLATCH
387	UDEF8 UNLATCH
388	UDEF9 UNLATCH
389	UDEF10 UNLATCH
390	UDEF11 UNLATCH
391	UDEF12 UNLATCH
392	UDEF13 UNLATCH
393	UDEF14 UNLATCH
394	UDEF15 UNLATCH
395	UDEF16 UNLATCH
396	REC LAMP
397	POWER ON









## Effects Parameters

### REVERB HALL, REVERB ROOM, REVERB STAGE, REVERB PLATE

One input, two output hall, room, stage, and plate reverb simulations, all with gates.

Parameter	Range	Description
REV TIME	0.3–99.0 s	Reverb time
INI. DLY	0.0–500.0 ms	Initial delay before reverb begins
HI. RATIO	0.1–1.0	High-frequency reverb time ratio
LO. RATIO	0.1–2.4	Low-frequency reverb time ratio
DIFF.	0–10	Reverb diffusion (left–right reverb spread)
DENSITY	0–100%	Reverb density
E/R DLY	0.0–100.0 ms	Delay between early reflections and reverb
E/R BAL.	0–100%	Balance of early reflections and reverb (0% = all reverb, 100% = all early reflections)
HPF	THRU, 21.2 Hz–8.00 kHz	High-pass filter cutoff frequency
LPF	50.0 Hz–16.0 kHz, THRU	Low-pass filter cutoff frequency
GATE LVL	OFF, –60 to 0 dB	Level at which gate kicks in
ATTACK	0–120 ms	Gate opening speed
HOLD	1	Gate open time
DECAY	2	Gate closing speed

- 0.02 ms–2.13 s (fs=44.1 kHz), 0.02 ms–1.96 s (fs=48 kHz), 0.01 ms–1.06 s (fs=88.2 kHz), 0.01 ms–981 ms (fs=96 kHz)
- 6.0 ms–46.0 s (fs=44.1 kHz), 5.0 ms–42.3 s (fs=48 kHz), 3 ms–23.0 s (fs=88.2 kHz), 3 ms–21.1 s (fs=96 kHz)

### EARLY REF.

One input, two output early reflections.

Parameter	Range	Description
TYPE	S-Hall, L-Hall, Random, Revers, Plate, Spring	Type of early reflection simulation
ROOMSIZE	0.1–20.0	Reflection spacing
LIVENESS	0–10	Early reflections decay characteristics (0 = dead, 10 = live)
INI. DLY	0.0–500.0 ms	Initial delay before reverb begins
DIFF.	0–10	Reflection diffusion (left–right reflection spread)
DENSITY	0–100%	Reflection density
ER NUM.	1–19	Number of early reflections
FB GAIN	–99 to +99%	Feedback gain
HI. RATIO	0.1–1.0	High-frequency feedback ratio
HPF	THRU, 21.2 Hz–8.00 kHz	High-pass filter cutoff frequency
LPF	50.0 Hz–16.0 kHz, THRU	Low-pass filter cutoff frequency

### GATE REVERB, REVERSE GATE

One input, two output early reflections with gate, and early reflections with reverse gate.

Parameter	Range	Description
TYPE	Type-A, Type-B	Type of early reflection simulation
ROOMSIZE	0.1–20.0	Reflection spacing
LIVENESS	0–10	Early reflections decay characteristics (0 = dead, 10 = live)
INI. DLY	0.0–500.0 ms	Initial delay before reverb begins
DIFF.	0–10	Reflection diffusion (left–right reflection spread)
DENSITY	0–100%	Reflection density
HI. RATIO	0.1–1.0	High-frequency feedback ratio
ER NUM.	1–19	Number of early reflections
FB GAIN	–99 to +99%	Feedback gain
HPF	THRU, 21.2 Hz–8.00 kHz	High-pass filter cutoff frequency
LPF	50.0 Hz–16.0 kHz, THRU	Low-pass filter cutoff frequency

## MONO DELAY

One input, one output basic repeat delay.

Parameter	Range	Description
DELAY	0.0–2730.0 ms	Delay time
FB. GAIN	–99 to +99%	Feedback gain (plus values for normal-phase feedback, minus values for reverse-phase feedback)
HI. RATIO	0.1–1.0	High-frequency feedback ratio
HPF	THRU, 21.2 Hz–8.00 kHz	High-pass filter cutoff frequency
LPF	50.0 Hz–16.0 kHz, THRU	Low-pass filter cutoff frequency
SYNC	OFF/ON	Tempo parameter sync on/off
NOTE	1	Used in conjunction with TEMPO to determine DELAY

1.  (Max. value depends on tempo setting)

## STEREO DELAY

Two input, two output basic stereo delay.

Parameter	Range	Description
DELAY L	0.0–1350.0 ms	Left channel delay time
DELAY R	0.0–1350.0 ms	Right channel delay time
FB. G L	–99 to +99%	Left channel feedback (plus values for normal-phase feedback, minus values for reverse-phase feedback)
FB. G R	–99 to +99%	Right channel feedback (plus values for normal-phase feedback, minus values for reverse-phase feedback)
HI. RATIO	0.1–1.0	High-frequency feedback ratio
HPF	THRU, 21.2 Hz–8.00 kHz	High-pass filter cutoff frequency
LPF	50.0 Hz–16.0 kHz, THRU	Low-pass filter cutoff frequency
SYNC	OFF/ON	Tempo parameter sync on/off
NOTE L	1	Used in conjunction with TEMPO to determine left channel DELAY
NOTE R	1	Used in conjunction with TEMPO to determine right channel DELAY

1.  (Maximum value depends on the tempo setting)

## MOD. DELAY

One input, two output basic repeat delay with modulation.

Parameter	Range	Description
DELAY	0.0–2725.0 ms	Delay time
FB. GAIN	–99 to +99%	Feedback gain (plus values for normal-phase feedback, minus values for reverse-phase feedback)
HI. RATIO	0.1–1.0	High-frequency feedback ratio
FREQ.	0.05–40.00 Hz	Modulation speed
DEPTH	0–100%	Modulation depth
WAVE	Sine/Tri	Modulation waveform
HPF	THRU, 21.2 Hz–8.00 kHz	High-pass filter cutoff frequency
LPF	50.0 Hz–16.0 kHz, THRU	Low-pass filter cutoff frequency
SYNC	OFF/ON	Tempo parameter sync on/off
DLY.NOTE	1	Used in conjunction with TEMPO to determine DELAY
MOD.NOTE	2	Used in conjunction with TEMPO to determine FREQ

1.  (Maximum value depends on the tempo setting)

2. 

**DELAY LCR**

One input, two output 3-tap delay (left, center, right).

Parameter	Range	Description
DELAY L	0.0–2730.0 ms	Left channel delay time
DELAY C	0.0–2730.0 ms	Center channel delay time
DELAY R	0.0–2730.0 ms	Right channel delay time
FB. DLY	0.0–2730.0 ms	Feedback delay time
LEVEL L	–100 to +100%	Left channel delay level
LEVEL C	–100 to +100%	Center channel delay level
LEVEL R	–100 to +100%	Right channel delay level
FB. GAIN	–99 to +99%	Feedback gain (plus values for normal-phase feedback, minus values for reverse-phase feedback)
HI. RATIO	0.1–1.0	High-frequency feedback ratio
HPF	THRU, 21.2 Hz–8.00 kHz	High-pass filter cutoff frequency
LPF	50.0 Hz–16.0 kHz, THRU	Low-pass filter cutoff frequency
SYNC	OFF/ON	Tempo parameter sync on/off
NOTE L	1	Used in conjunction with TEMPO to determine DELAY L
NOTE C	1	Used in conjunction with TEMPO to determine DELAY C
NOTE R	1	Used in conjunction with TEMPO to determine DELAY R
NOTE FB	1	Used in conjunction with TEMPO to determine FB. DLY

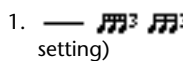
1.  (Maximum value depends on the tempo setting)

**ECHO**

Two input, two output stereo delay with crossed feedback loop.

Parameter	Range	Description
DELAY L	0.0–1350.0 ms	Left channel delay time
DELAY R	0.0–1350.0 ms	Right channel delay time
FB.DLY L	0.0–1350.0 ms	Left channel feedback delay time
FB.DLY R	0.0–1350.0 ms	Right channel feedback delay time
FB. G L	–99 to +99%	Left channel feedback gain (plus values for normal-phase feedback, minus values for reverse-phase feedback)
FB. G R	–99 to +99%	Right channel feedback gain (plus values for normal-phase feedback, minus values for reverse-phase feedback)
L->R FBG	–99 to +99%	Left to right channel feedback gain (plus values for normal-phase feedback, minus values for reverse-phase feedback)
R->L FBG	–99 to +99%	Right to left channel feedback gain (plus values for normal-phase feedback, minus values for reverse-phase feedback)
HI. RATIO	0.1–1.0	High-frequency feedback ratio
HPF	THRU, 21.2 Hz–8.00 kHz	High-pass filter cutoff frequency
LPF	50.0 Hz–16.0 kHz, THRU	Low-pass filter cutoff frequency
SYNC	OFF/ON	Tempo parameter sync on/off
NOTE L	1	Used in conjunction with TEMPO to determine DELAY L
NOTE R	1	Used in conjunction with TEMPO to determine DELAY R
NOTE FBL	1	Used in conjunction with TEMPO to determine FB. D L
NOTE FBR	1	Used in conjunction with TEMPO to determine FB. D R

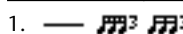
1.  (Maximum value depends on the tempo setting)



## CHORUS

Two input, two output chorus effect.

Parameter	Range	Description
FREQ.	0.05–40.00 Hz	Modulation speed
AM DEPTH	0–100%	Amplitude modulation depth
PM DEPTH	0–100%	Pitch modulation depth
MOD. DLY	0.0–500.0 ms	Modulation delay time
WAVE	Sine, Tri	Modulation waveform
LSH F	21.2 Hz–8.00 kHz	Low shelving filter frequency
LSH G	–12 to +12 dB	Low shelving filter gain
EQ F	100 Hz–8.00 kHz	EQ (peaking type) frequency
EQ G	–12 to +12 dB	EQ (peaking type) gain
EQ Q	10.0–0.10	EQ (peaking type) bandwidth
HSH F	50.0 Hz–16.0 kHz	High shelving filter frequency
HSH G	–12 to +12 dB	High shelving filter gain
SYNC	OFF/ON	Tempo parameter sync on/off
NOTE	<sup>1</sup>	Used in conjunction with TEMPO to determine FREQ.

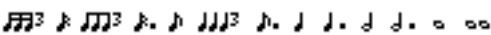
1. 

## FLANGE

Two input, two output flange effect.

Parameter	Range	Description
FREQ.	0.05–40.00 Hz	Modulation speed
DEPTH	0–100%	Modulation depth
MOD. DLY	0.0–500.0 ms	Modulation delay time
FB. GAIN	–99 to +99%	Feedback gain (plus values for normal-phase feedback, minus values for reverse-phase feedback)
WAVE	Sine, Tri	Modulation waveform
LSH F	21.2 Hz–8.00 kHz	Low shelving filter frequency
LSH G	–12 to +12 dB	Low shelving filter gain
EQ F	100 Hz–8.00 kHz	EQ (peaking type) frequency
EQ G	–12 to +12 dB	EQ (peaking type) gain
EQ Q	10.0–0.10	EQ (peaking type) bandwidth
HSH F	50.0 Hz–16.0 kHz	High shelving filter frequency
HSH G	–12 to +12 dB	High shelving filter gain
SYNC	OFF/ON	Tempo parameter sync on/off
NOTE	<sup>1</sup>	Used in conjunction with TEMPO to determine FREQ.

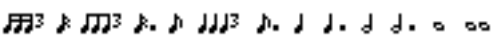
1. 

### SYMPHONIC

Two input, two output symphonic effect.

Parameter	Range	Description
FREQ.	0.05–40.00 Hz	Modulation speed
DEPTH	0–100%	Modulation depth
MOD. DLY	0.0–500.0 ms	Modulation delay time
WAVE	Sine, Tri	Modulation waveform
LSH F	21.2 Hz–8.00 kHz	Low shelving filter frequency
LSH G	–12 to +12 dB	Low shelving filter gain
EQ F	100 Hz–8.00 kHz	EQ (peaking type) frequency
EQ G	–12 to +12 dB	EQ (peaking type) gain
EQ Q	10.0–0.10	EQ (peaking type) bandwidth
HSH F	50.0 Hz–16.0 kHz	High shelving filter frequency
HSH G	–12 to +12 dB	High shelving filter gain
SYNC	OFF/ON	Tempo parameter sync on/off
NOTE	<sup>1</sup>	Used in conjunction with TEMPO to determine FREQ.

1. 

### PHASER

Two input, two output 16-stage phaser.

Parameter	Range	Description
FREQ.	0.05–40.00 Hz	Modulation speed
DEPTH	0–100%	Modulation depth
FB. GAIN	–99 to +99%	Feedback gain (plus values for normal-phase feedback, minus values for reverse-phase feedback)
OFFSET	0–100	Lowest phase-shifted frequency offset
PHASE	0.00–354.38 degrees	Left and right modulation phase balance
STAGE	2, 4, 6, 8, 10, 12, 14, 16	Number of phase shift stages
LSH F	21.2 Hz–8.00 kHz	Low shelving filter frequency
LSH G	–12 to +12 dB	Low shelving filter gain
HSH F	50.0 Hz–16.0 kHz	High shelving filter frequency
HSH G	–12 to +12 dB	High shelving filter gain
SYNC	OFF/ON	Tempo parameter sync on/off
NOTE	<sup>1</sup>	Used in conjunction with TEMPO to determine FREQ.

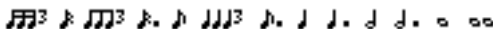
1. 

## AUTOPAN

Two input, two output autopanner.

Parameter	Range	Description
FREQ.	0.05–40.00 Hz	Modulation speed
DEPTH	0–100%	Modulation depth
DIR.	1	Panning direction
WAVE	Sine, Tri, Square	Modulation waveform
LSH F	21.2 Hz–8.00 kHz	Low shelving filter frequency
LSH G	–12 to +12 dB	Low shelving filter gain
EQ F	100 Hz–8.00 kHz	EQ (peaking type) frequency
EQ G	–12 to +12 dB	EQ (peaking type) gain
EQ Q	10.0–0.10	EQ (peaking type) bandwidth
HSH F	50.0 Hz–16.0 kHz	High shelving filter frequency
HSH G	–12 to +12 dB	High shelving filter gain
SYNC	OFF/ON	Tempo parameter sync on/off
NOTE	2	Used in conjunction with TEMPO to determine FREQ.

1. L<->R, L->R, L<-R, Turn L, Turn R

2. 

## TREMOLO

Two input, two output tremolo effect.

Parameter	Range	Description
FREQ.	0.05–40.00 Hz	Modulation speed
DEPTH	0–100%	Modulation depth
WAVE	Sine, Tri, Square	Modulation waveform
LSH F	21.2 Hz–8.00 kHz	Low shelving filter frequency
LSH G	–12 to +12 dB	Low shelving filter gain
EQ F	100 Hz–8.00 kHz	EQ (peaking type) frequency
EQ G	–12 to +12 dB	EQ (peaking type) gain
EQ Q	10.0–0.10	EQ (peaking type) bandwidth
HSH F	50.0 Hz–16.0 kHz	High shelving filter frequency
HSH G	–12 to +12 dB	High shelving filter gain
SYNC	OFF/ON	Tempo parameter sync on/off
NOTE	1	Used in conjunction with TEMPO to determine FREQ.

1. 

## HQ. PITCH

One input, two output high-quality pitch shifter.

Parameter	Range	Description
PITCH	–12 to +12 semitones	Pitch shift
FINE	–50 to +50 cents	Pitch shift fine
DELAY	0.0–1000.0 ms	Delay time
FB. GAIN	–99 to +99%	Feedback gain (plus values for normal-phase feedback, minus values for reverse-phase feedback)
MODE	1–10	Pitch shift precision
SYNC	OFF/ON	Tempo parameter sync on/off
NOTE	1	Used in conjunction with TEMPO to determine DELAY

1.  (Maximum value depends on the tempo setting)

### DUAL PITCH

Two input, two output pitch shifter.

Parameter	Range	Description
PITCH 1	-24 to +24 semitones	Channel #1 pitch shift
FINE 1	-50 to +50 cents	Channel #1 pitch shift fine
LEVEL 1	-100 to +100%	Channel #1 level (plus values for normal phase, minus values for reverse phase)
PAN 1	L63 to R63	Channel #1 pan
DELAY 1	0.0-1000.0 ms	Channel #1 delay time
FB. G 1	-99 to +99%	Channel #1 feedback gain (plus values for normal-phase feedback, minus values for reverse-phase feedback)
PITCH 2	-24 to +24 semitones	Channel #2 pitch shift
FINE 2	-50 to +50 cents	Channel #2 pitch shift fine
LEVEL 2	-100 to +100%	Channel #2 level (plus values for normal phase, minus values for reverse phase)
PAN 2	L63 to R63	Channel #2 pan
DELAY 2	0.0-1000.0 ms	Channel #2 delay time
FB. G 2	-99 to +99%	Channel #2 feedback gain (plus values for normal-phase feedback, minus values for reverse-phase feedback)
MODE	1-10	Pitch shift precision
SYNC	OFF/ON	Tempo parameter sync on/off
NOTE 1	1	Used in conjunction with TEMPO to determine Channel #1 delay
NOTE 2	1	Used in conjunction with TEMPO to determine Channel #2 delay

1.  (Maximum value depends on the tempo setting)

### ROTARY

One input, two output rotary speaker simulator.

Parameter	Range	Description
ROTATE	STOP, START	Rotation stop, start
SPEED	SLOW, FAST	Rotation speed (see SLOW and FAST parameters)
SLOW	0.05-10.00 Hz	SLOW rotation speed
FAST	0.05-10.00 Hz	FAST rotation speed
DRIVE	0-100	Overdrive level
ACCEL	0-10	Acceleration at speed changes
LOW	0-100	Low-frequency filter
HIGH	0-100	High-frequency filter

### RING MOD.

Two input, two output ring modulator.

Parameter	Range	Description
SOURCE	OSC, SELF	Modulation source: oscillator or input signal
OSC FREQ	0.0-5000.0 Hz	Oscillator frequency
FM FREQ.	0.05-40.00 Hz	Oscillator frequency modulation speed
FM DEPTH	0-100%	Oscillator frequency modulation depth
SYNC	OFF/ON	Tempo parameter sync on/off
NOTE FM	1	Used in conjunction with TEMPO to determine FM FREQ

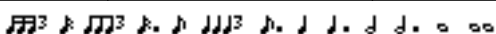
1. 

## MOD. FILTER

Two input, two output modulation filter.

Parameter	Range	Description
FREQ.	0.05–40.00 Hz	Modulation speed
DEPTH	0–100%	Modulation depth
PHASE	0.00–354.38 degrees	Left-channel modulation and right-channel modulation phase difference
TYPE	LPF, HPF, BPF	Filter type: low pass, high pass, band pass
OFFSET	0–100	Filter frequency offset
RESO.	0–20	Filter resonance
LEVEL	0–100	Output level
SYNC	OFF/ON	Tempo parameter sync on/off
NOTE	1	Used in conjunction with TEMPO to determine FREQ

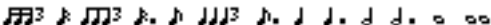
1. 

## DISTORTION

One input, two output distortion effect.

Parameter	Range	Description
DST TYPE	DST1, DST2, OVD1, OVD2, CRUNCH	Distortion type (DST = distortion, OVD = overdrive)
DRIVE	0–100	Distortion drive
MASTER	0–100	Master volume
TONE	–10 to +10	Tone
N. GATE	0–20	Noise reduction

## AMP SIMULATE

One input, two output guitar amp simulator.

Parameter	Range	Description
AMP TYPE	1	Guitar amp simulation type
DST TYPE	DST1, DST2, OVD1, OVD2, CRUNCH	Distortion type (DST = distortion, OVD = overdrive)
DRIVE	0–100	Distortion drive
MASTER	0–100	Master volume
BASS	0–100	Bass tone control
MIDDLE	0–100	Middle tone control
TREBLE	0–100	High tone control
CAB DEP	0–100%	Speaker cabinet simulation depth
EQ F	100 Hz–8.0 kHz	EQ (peaking type) frequency
EQ G	–12 to +12 dB	EQ (peaking type) gain
EQ Q	10.0–0.10	EQ (peaking type) bandwidth
N. GATE	0–20	Noise reduction

1. STK-M1, STK-M2, THRASH, MIDBST, CMB-PG, CMB-VR, CMB-DX, CMB-TW, MINI, FLAT

**DYNA. FILTER**

Two input, two output dynamically controlled filter.

Parameter	Range	Description
SOURCE	INPUT, MIDI	Control source: input signal or MIDI Note On velocity
SENSE	0–100	Sensitivity
DIR.	UP, DOWN	Upward or downward frequency change
DECAY	1	Filter frequency change decay speed
TYPE	LPF, HPF, BPF	Filter type
OFFSET	0–100	Filter frequency offset
RESO.	0–20	Filter resonance
LEVEL	0–100	Output Level

1. 6.0 ms–46.0 s (fs=44.1 kHz), 5.0 ms–42.3 s (fs=48 kHz), 3 ms–23.0 s (fs=88.2 kHz), 3 ms–21.1 s (fs=96 kHz)

**DYNA. FLANGE**

Two input, two output dynamically controlled flanger.

Parameter	Range	Description
SOURCE	INPUT, MIDI	Control source: input signal or MIDI Note On velocity
SENSE	0–100	Sensitivity
DIR.	UP, DOWN	Upward or downward frequency change
DECAY	1	Decay speed
OFFSET	0–100	Delay time offset
FB.GAIN	–99 to +99%	Feedback gain (plus values for normal-phase feedback, minus values for reverse-phase feedback)
LSH F	21.2 Hz–8.00 kHz	Low shelving filter frequency
LSH G	–12 to +12 dB	Low shelving filter gain
EQ F	100 Hz–8.00 kHz	EQ (peaking type) frequency
EQ G	–12 to +12 dB	EQ (peaking type) gain
EQ Q	10.0–0.10	EQ (peaking type) bandwidth
HSH F	50.0 Hz–16.0 kHz	High shelving filter frequency
HSH G	–12 to +12 dB	High shelving filter gain

1. 6.0 ms–46.0 s (fs=44.1 kHz), 5.0 ms–42.3 s (fs=48 kHz), 3 ms–23.0 s (fs=88.2 kHz), 3 ms–21.1 s (fs=96 kHz)

**DYNA. PHASER**

Two input, two output dynamically controlled phaser.

Parameter	Range	Description
SOURCE	INPUT, MIDI	Control source: input signal or MIDI Note On velocity
SENSE	0–100	Sensitivity
DIR.	UP, DOWN	Upward or downward frequency change
DECAY	1	Decay speed
OFFSET	0–100	Lowest phase-shifted frequency offset
FB.GAIN	–99 to +99%	Feedback gain (plus values for normal-phase feedback, minus values for reverse-phase feedback)
STAGE	2, 4, 6, 8, 10, 12, 14, 16	Number of phase shift stages
LSH F	21.2 Hz–8.00 kHz	Low shelving filter frequency
LSH G	–12 to +12 dB	Low shelving filter gain
HSH F	50.0 Hz–16.0 kHz	High shelving filter frequency
HSH G	–12 to +12 dB	High shelving filter gain

1. 6.0 ms–46.0 s (fs=44.1 kHz), 5.0 ms–42.3 s (fs=48 kHz), 3 ms–23.0 s (fs=88.2 kHz), 3 ms–21.1 s (fs=96 kHz)

**REV+CHORUS**

One input, two output reverb and chorus effects in parallel.

Parameter	Range	Description
REV TIME	0.3–99.0 s	Reverb time
INI. DLY	0.0–500.0 ms	Initial delay before reverb begins
HI. RATIO	0.1–1.0	High-frequency reverb time ratio
DIFF.	0–10	Spread
DENSITY	0–100%	Reverb density
HPF	THRU, 21.2 Hz–8.00 kHz	High-pass filter cutoff frequency
LPF	50.0 Hz–16.0 kHz, THRU	Low-pass filter cutoff frequency
REV/CHO	0–100%	Reverb and chorus balance (0% = all reverb, 100% = all chorus)
FREQ.	0.05–40.00 Hz	Modulation speed
AM DEPTH	0–100%	Amplitude modulation depth
PM DEPTH	0–100%	Pitch modulation depth
MOD. DLY	0.0–500.0 ms	Modulation delay time
WAVE	Sine, Tri	Modulation waveform
SYNC	OFF/ON	Tempo parameter sync on/off
NOTE	<sup>1</sup>	Used in conjunction with TEMPO to determine FREQ.

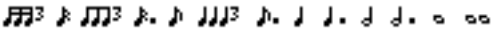
1. 

**REV->CHORUS**

One input, two output reverb and chorus effects in series.

Parameter	Range	Description
REV TIME	0.3–99.0 s	Reverb time
INI. DLY	0.0–500.0 ms	Initial delay before reverb begins
HI. RATIO	0.1–1.0	High-frequency reverb time ratio
DIFF.	0–10	Spread
DENSITY	0–100%	Reverb density
HPF	THRU, 21.2 Hz–8.00 kHz	High-pass filter cutoff frequency
LPF	50.0 Hz–16.0 kHz, THRU	Low-pass filter cutoff frequency
REV.BAL	0–100%	Reverb and chorused reverb balance (0% = all chorused reverb, 100% = all reverb)
FREQ.	0.05–40.00 Hz	Modulation speed
AM DEPTH	0–100%	Amplitude modulation depth
PM DEPTH	0–100%	Pitch modulation depth
MOD. DLY	0.0–500.0 ms	Modulation delay time
WAVE	Sine, Tri	Modulation waveform
SYNC	OFF/ON	Tempo parameter sync on/off
NOTE	<sup>1</sup>	Used in conjunction with TEMPO to determine FREQ.

1. 

**REV+FLANGE**

One input, two output reverb and flanger effects in parallel.

Parameter	Range	Description
REV TIME	0.3–99.0 s	Reverb time
INI. DLY	0.0–500.0 ms	Initial delay before reverb begins
HI. RATIO	0.1–1.0	High-frequency reverb time ratio
DIFF.	0–10	Spread
DENSITY	0–100%	Reverb density
HPF	THRU, 21.2 Hz–8.00 kHz	High-pass filter cutoff frequency
LPF	50.0 Hz–16.0 kHz, THRU	Low-pass filter cutoff frequency
REV/FLG	0–100%	Reverb and flange balance (0% = all reverb, 100% = all flange)
FREQ.	0.05–40.00 Hz	Modulation speed
DEPTH	0–100%	Modulation depth
MOD. DLY	0.0–500.0 ms	Modulation delay time
FB. GAIN	–99 to +99%	Feedback gain (plus values for normal-phase feedback, minus values for reverse-phase feedback)
WAVE	Sine, Tri	Modulation waveform
SYNC	OFF/ON	Tempo parameter sync on/off
NOTE	1	Used in conjunction with TEMPO to determine FREQ.

1. 

**REV->FLANGE**

One input, two output reverb and flanger effects in series.

Parameter	Range	Description
REV TIME	0.3–99.0 s	Reverb time
INI. DLY	0.0–500.0 ms	Initial delay before reverb begins
HI. RATIO	0.1–1.0	High-frequency reverb time ratio
DIFF.	0–10	Spread
DENSITY	0–100%	Reverb density
HPF	THRU, 21.2 Hz–8.00 kHz	High-pass filter cutoff frequency
LPF	50.0 Hz–16.0 kHz, THRU	Low-pass filter cutoff frequency
REV.BAL	0–100%	Reverb and flanged reverb balance (0% = all flanged reverb, 100% = all reverb)
FREQ.	0.05–40.00 Hz	Modulation speed
DEPTH	0–100%	Modulation depth
MOD. DLY	0.0–500.0 ms	Modulation delay time
FB. GAIN	–99 to +99%	Feedback gain (plus values for normal-phase feedback, minus values for reverse-phase feedback)
WAVE	Sine, Tri	Modulation waveform
SYNC	OFF/ON	Tempo parameter sync on/off
NOTE	1	Used in conjunction with TEMPO to determine FREQ.

1. 



**REV+SYMPHO.**

One input, two output reverb and symphonic effects in parallel.

Parameter	Range	Description
REV TIME	0.3–99.0 s	Reverb time
INI. DLY	0.0–500.0 ms	Initial delay before reverb begins
HI. RATIO	0.1–1.0	High-frequency reverb time ratio
DIFF.	0–10	Spread
DENSITY	0–100%	Reverb density
HPF	THRU, 21.2 Hz–8.00 kHz	High-pass filter cutoff frequency
LPF	50.0 Hz–16.0 kHz, THRU	Low-pass filter cutoff frequency
REV/SYM	0–100%	Reverb and symphonic balance (0% = all reverb, 100% = all symphonic)
FREQ.	0.05–40.00 Hz	Modulation speed
DEPTH	0–100%	Modulation depth
MOD. DLY	0.0–500.0 ms	Modulation delay time
WAVE	Sine, Tri	Modulation waveform
SYNC	OFF/ON	Tempo parameter sync on/off
NOTE	<sup>1</sup>	Used in conjunction with TEMPO to determine FREQ.

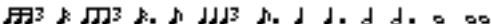
1. 

**REV->SYMPHO.**

One input, two output reverb and symphonic effects in series.

Parameter	Range	Description
REV TIME	0.3–99.0 s	Reverb time
INI. DLY	0.0–500.0 ms	Initial delay before reverb begins
HI. RATIO	0.1–1.0	High-frequency reverb time ratio
DIFF.	0–10	Spread
DENSITY	0–100%	Reverb density
HPF	THRU, 21.2 Hz–8.00 kHz	High-pass filter cutoff frequency
LPF	50.0 Hz–16.0 kHz, THRU	Low-pass filter cutoff frequency
REV.BAL	0–100%	Reverb and symphonic reverb balance (0% = all symphonic reverb, 100% = all reverb)
FREQ.	0.05–40.00 Hz	Modulation speed
DEPTH	0–100%	Modulation depth
MOD. DLY	0.0–500.0 ms	Modulation delay time
WAVE	Sine, Tri	Modulation waveform
SYNC	OFF/ON	Tempo parameter sync on/off
NOTE	<sup>1</sup>	Used in conjunction with TEMPO to determine FREQ.

1. 

**REV->PAN**

One input, two output reverb and autopan effects in parallel.

Parameter	Range	Description
REV TIME	0.3–99.0 s	Reverb time
INI. DLY	0.0–500.0 ms	Initial delay before reverb begins
HI. RATIO	0.1–1.0	High-frequency reverb time ratio
DIFF.	0–10	Spread
DENSITY	0–100%	Reverb density
HPF	THRU, 21.2 Hz–8.00 kHz	High-pass filter cutoff frequency
LPF	50.0 Hz–16.0 kHz, THRU	Low-pass filter cutoff frequency
REV.BAL	0–100%	Reverb and panned reverb balance (0% = all panned reverb, 100% = all reverb)
FREQ.	0.05–40.00 Hz	Modulation speed
DEPTH	0–100%	Modulation depth
DIR.	1	Panning direction
WAVE	Sine, Tri, Square	Modulation waveform
SYNC	OFF/ON	Tempo parameter sync on/off
NOTE	2	Used in conjunction with TEMPO to determine FREQ.

1. L<->R, L->R, L<-R, Turn L, Turn R

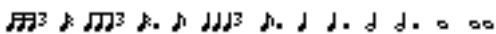
2. 

**DELAY+ER.**

One input, two output delay and early reflections effects in parallel.

Parameter	Range	Description
DELAY L	0.0–1000.0 ms	Left channel delay time
DELAY R	0.0–1000.0 ms	Right channel delay time
FB. DLY	0.0–1000.0 ms	Feedback delay time
FB. GAIN	–99 to +99%	Feedback gain (plus values for normal-phase feedback, minus values for reverse-phase feedback)
HI. RATIO	0.1–1.0	High-frequency feedback ratio
HPF	THRU, 21.2 Hz–8.00 kHz	High-pass filter cutoff frequency
LPF	50.0 Hz–16.0 kHz, THRU	Low-pass filter cutoff frequency
DLY/ER	0–100%	Delay and early reflections balance (0% = all delay, 100% = all early reflections)
TYPE	S-Hall, L-Hall, Random, Revers, Plate, Spring	Type of early reflection simulation
ROOMSIZE	0.1–20.0	Reflection spacing
LIVENESS	0–10	Early reflections decay characteristics (0 = dead, 10 = live)
INI. DLY	0.0–500.0 ms	Initial delay before reverb begins
DIFF.	0–10	Spread
DENSITY	0–100%	Reverb density
ER NUM.	1–19	Number of early reflections
SYNC	OFF/ON	Tempo parameter sync on/off
NOTE L	1	Used in conjunction with TEMPO to determine left channel DELAY L
NOTE R	1	Used in conjunction with TEMPO to determine right channel DELAY R
NOTE FB	1	Used in conjunction with TEMPO to determine FB. DLY

1.  (Maximum value depends on the tempo setting)

**DELAY->ER.**

One input, two output delay and early reflections effects in series.

Parameter	Range	Description
DELAY L	0.0–1000.0 ms	Left channel delay time
DELAY R	0.0–1000.0 ms	Right channel delay time
FB. DLY	0.0–1000.0 ms	Feedback delay time
FB. GAIN	–99 to +99%	Feedback gain (plus values for normal-phase feedback, minus values for reverse-phase feedback)
HI. RATIO	0.1–1.0	High-frequency feedback ratio
HPF	THRU, 21.2 Hz–8.00 kHz	High-pass filter cutoff frequency
LPF	50.0 Hz–16.0 kHz, THRU	Low-pass filter cutoff frequency
DLY.BAL	0–100%	Delay and early reflected delay balance (0% = all early reflected delay, 100% = all delay)
TYPE	S-Hall, L-Hall, Random, Revers, Plate, Spring	Type of early reflection simulation
ROOMSIZE	0.1–20.0	Reflection spacing
LIVENESS	0–10	Early reflections decay characteristics (0 = dead, 10 = live)
INI. DLY	0.0–500.0 ms	Initial delay before reverb begins
DIFF.	0–10	Spread
DENSITY	0–100%	Reverb density
ER NUM.	1–19	Number of early reflections
SYNC	OFF/ON	Tempo parameter sync on/off
NOTE L	1	Used in conjunction with TEMPO to determine left channel DELAY L
NOTE R	1	Used in conjunction with TEMPO to determine right channel DELAY R
NOTE FB	1	Used in conjunction with TEMPO to determine FB. DLY

1. —  (Maximum value depends on the tempo setting)

**DELAY+REV**

One input, two output delay and reverb effects in parallel.

Parameter	Range	Description
DELAY L	0.0–1000.0 ms	Left channel delay time
DELAY R	0.0–1000.0 ms	Right channel delay time
FB. DLY	0.0–1000.0 ms	Feedback delay time
FB. GAIN	–99 to +99%	Feedback gain (plus values for normal-phase feedback, minus values for reverse-phase feedback)
DELAY HI	0.1–1.0	Delay high-frequency feedback ratio
HPF	THRU, 21.2 Hz–8.00 kHz	High-pass filter cutoff frequency
LPF	50.0 Hz–16.0 kHz, THRU	Low-pass filter cutoff frequency
DLY/REV	0–100%	Delay and reverb balance (0% = all delay, 100% = all reverb)
REV TIME	0.3–99.0 s	Reverb time
INI. DLY	0.0–500.0 ms	Initial delay before reverb begins
REV HI	0.1–1.0	High-frequency reverb time ratio
DIFF.	0–10	Spread
DENSITY	0–100%	Reverb density
SYNC	OFF/ON	Tempo parameter sync on/off
NOTE L	1	Used in conjunction with TEMPO to determine left channel DELAY L
NOTE R	1	Used in conjunction with TEMPO to determine right channel DELAY R
NOTE FB	1	Used in conjunction with TEMPO to determine FB. DLY

1. —  (Maximum value depends on the tempo setting)

**DELAY->REV**

One input, two output delay and reverb effects in series.

Parameter	Range	Description
DELAY L	0.0–1000.0 ms	Left channel delay time
DELAY R	0.0–1000.0 ms	Right channel delay time
FB. DLY	0.0–1000.0 ms	Feedback delay time
FB. GAIN	–99 to +99%	Feedback gain (plus values for normal-phase feedback, minus values for reverse-phase feedback)
DELAY HI	0.1–1.0	Delay high-frequency feedback ratio
HPF	THRU, 21.2 Hz–8.00 kHz	High-pass filter cutoff frequency
LPF	50.0 Hz–16.0 kHz, THRU	Low-pass filter cutoff frequency
DLY.BAL	0–100%	Delay and delayed reverb balance (0% = all delayed reverb, 100% = all delay)
REV TIME	0.3–99.0 s	Reverb time
INI. DLY	0.0–500.0 ms	Initial delay before reverb begins
REV HI	0.1–1.0	High-frequency reverb time ratio
DIFF.	0–10	Spread
DENSITY	0–100%	Reverb density
SYNC	OFF/ON	Tempo parameter sync on/off
NOTE L	1	Used in conjunction with TEMPO to determine left channel DELAY L
NOTE R	*1	Used in conjunction with TEMPO to determine right channel DELAY R
NOTE FB	*1	Used in conjunction with TEMPO to determine FB. DLY

1.  (Maximum value depends on the tempo setting)

**DIST->DELAY**

One input, two output distortion and delay effects in series.

Parameter	Range	Description
DST TYPE	DST1, DST2, OVD1, OVD2, CRUNCH	Distortion type (DST = distortion, OVD = overdrive)
DRIVE	0–100	Distortion drive
MASTER	0–100	Master volume
tone	–10 to +10	Tone control
N. GATE	0–20	Noise reduction
DELAY	0.0–2725.0 ms	Delay time
FB. GAIN	–99 to +99%	Feedback gain (plus values for normal-phase feedback, minus values for reverse-phase feedback)
HI. RATIO	0.1–1.0	High-frequency feedback ratio
FREQ.	0.05–40.00 Hz	Modulation speed
DEPTH	0–100%	Modulation depth
DLY.BAL	0–100%	Distortion and delay balance (0% = all distortion, 100% = all delayed distortion)
SYNC	OFF/ON	Tempo parameter sync on/off
DLY.NOTE	1	Used in conjunction with TEMPO to determine DELAY
MOD.NOTE	2	Used in conjunction with TEMPO to determine FREQ.

1.  (Maximum value depends on the tempo setting)

2. 

## MULTI FILTER

Two input, two output 3-band multi-filter (24 dB/octave).

Parameter	Range	Description
TYPE 1	HPF, LPF, BPF	Filter 1 type: high pass, low pass, band pass
TYPE 2	HPF, LPF, BPF	Filter 2 type: high pass, low pass, band pass
TYPE 3	HPF, LPF, BPF	Filter 3 type: high pass, low pass, band pass
FREQ. 1	28.0 Hz–16.0 kHz	Filter 1 frequency
FREQ. 2	28.0 Hz–16.0 kHz	Filter 2 frequency
FREQ. 3	28.0 Hz–16.0 kHz	Filter 3 frequency
LEVEL 1	0–100	Filter 1 level
LEVEL 2	0–100	Filter 2 level
LEVEL 3	0–100	Filter 3 level
RESO. 1	0–20	Filter 1 resonance
RESO. 2	0–20	Filter 2 resonance
RESO. 3	0–20	Filter 3 resonance

## FREEZE

One input, one output basic sampler.

Parameter	Range	Description
REC MODE	MANUAL, INPUT	In MANUAL mode, recording is started by pressing the REC and PLAY buttons. In INPUT mode, Record-Ready mode is engaged by pressing the REC button, and actual recording is triggered by the input signal.
REC DLY	–1000 to +1000 ms	Recording delay. For plus values, recording starts after the trigger is received. For minus values, recording starts before the trigger is received.
TRG LVL	–60 to 0 dB	Input trigger level (i.e., the signal level required to trigger recording or playback)
TRG MASK	0–1000 ms	Once playback has been triggered, subsequent triggers are ignored for the duration of the TRG MASK time.
PLY MODE	MOMENT, CONTI., INPUT	In MOMENT mode, the sample plays only while the that the PLAY button is pressed. In CONT mode, playback continues once the PLAY button has been pressed. The number of times the sample plays is set using the LOOP NUM parameter. In INPUT mode, playback is triggered by the input signal.
START	1	Playback start point in milliseconds
END	1	Playback end point in milliseconds
LOOP	1	Loop start point in milliseconds
LOOP NUM	0–100	Number of times the sample plays
START [SAMPLE]	0–262000	Playback start point in samples
END [SAMPLE]	0–262000	Playback end point in samples
LOOP [SAMPLE]	0–262000	Loop start point in samples
PITCH	–12 to +12 semitones	Playback pitch shift
FINE	–50 to +50 cents	Playback pitch shift fine
MIDI TRG	OFF, C1–C6, ALL	PLAY button can be triggered by using MIDI Note on/off messages.

1. 0.0–5941.0 ms (fs=44.1 kHz), 0.0 ms–5458.3 ms (fs=48 kHz), 0.0–2970.5 ms (fs=88.2 kHz), 0.0 ms–2729.2 ms (fs=96 kHz)

**ST REVERB**

Two input, two output stereo reverb.

Parameter	Range	Description
REV TIME	0.3–99.0 s	Reverb time
REV TYPE	Hall, Room, Stage, Plate	Reverb type
INI. DLY	0.0–100.0 ms	Initial delay before reverb begins
HI. RATIO	0.1–1.0	High-frequency reverb time ratio
LO. RATIO	0.1–2.4	Low-frequency reverb time ratio
DIFF.	0–10	Reverb diffusion (left–right reverb spread)
DENSITY	0–100%	Reverb density
E/R BAL.	0–100%	Balance of early reflections and reverb (0% = all reverb, 100% = all early reflections)
HPF	THRU, 21.2 Hz–8.00 kHz	High-pass filter cutoff frequency
LPF	50.0 Hz–16.0 kHz, THRU	Low-pass filter cutoff frequency

**REVERB 5.1**

One input, six output reverb for 5.1 surround, with surround panning.

Parameter	Range	Description
REV TIME	0.3–99.0 s	Reverb time
REV TYPE	Hall, Room, Stage, Plate	Reverb type
HI. RATIO	0.1–1.0	High-frequency reverb time ratio
DIFF.	0–10	Reverb diffusion (left–right reverb spread)
DENSITY	0–100%	Reverb density
HPF	THRU, 21.2 Hz–8.00 kHz	High-pass filter cutoff frequency
LPF	50.0 Hz–16.0 kHz, THRU	Low-pass filter cutoff frequency
DIV.	0–100%	Divergence determines how the front center signal is fed to the Left, Right, and Center channels. When set to 0%, it's fed only to the Left and Right channels (i.e., Phantom Center). When set to 50%, it's fed equally to the Left, Right, and Center channels. When set to 100%, it's fed to only the Center channel (i.e., Real Center).
ROOMSIZE	0.1–20.0	Size of simulated room's reverb
POS L/R	L63–R63	Left/right listening position
POS F/R	F63–R63	Front/rear listening position
POS CTRL	OFF, NORMAL, INVERT	1
ER L/R	L63–R63	Left/right early reflections position
ER F/R	F63–R63	Front/rear early reflections position
ER LVL	0–100%	Early reflections level
ER CTRL	OFF, NORMAL, INVERT	1
REV L/R	L63–R63	Left/right reverb position
REV F/R	F63–R63	Front/rear reverb position
REV LVL	0–100%	Reverb level
REV CTRL	OFF, NORMAL, INVERT	1
POS RAD.	0–63	Radius of the panning track at the listening position
ER RAD.	0–63	Radius of the panning track for early reflections
REV RAD.	0–63	Radius of the panning track for reverb

1. When set to NOR, the position can be set by using the Joystick so long as the SELECTED CHANNEL PAN/SURROUND [EFFECT] button's indicator is on. When set to INV, the Joystick will work inversely. When set to OFF, Joystick control is off. The CTRL button on the Effect Edit page works the same as the [EFFECT] button.

## OCTA REVERB

Eight input, eight output reverb.

Parameter	Range	Description
REV TIME	0.3–99.0 s	Reverb time
REV TYPE	Hall, Room, Stage, Plate	Reverb type
INI. DLY	0.0–100.0 ms	Initial delay before reverb begins
HI. RATIO	0.1–1.0	High-frequency reverb time ratio
LO. RATIO	0.1–2.4	Low-frequency reverb time ratio
DIFF.	0–10	Reverb diffusion (left–right reverb spread)
DENSITY	0–100%	Reverb density
E/R BAL.	0–100%	Balance of early reflections and reverb (0% = all reverb, 100% = all early reflections)
HPF	THRU, 21.2 Hz–8.00 kHz	High-pass filter cutoff frequency
LPF	50.0 Hz–16.0 kHz, THRU	Low-pass filter cutoff frequency

## AUTO PAN 5.1

Six input, six output autopanner for 5.1 surround. You can reset to the pan position specified by the OFFSET parameter by pressing the RESET button.

Parameter	Range	Description
SOURCE	OFF, HOLD, INPUT1, INPUT2, INPUT3, INPUT4, INPUT5, INPUT6, MIDI	When set to OFF, the TRIGGER button is used to start autopan. When set to HOLD, autopan runs continuously. When set to INPUT 1–6, the specified channel's input signal triggers autopan. When set to MIDI, a MIDI Note On message can be used to trigger autopan.
TRIG. LVL	–60 to 0 dB	Input trigger level (i.e., the signal level required to trigger panning when SOURCE set to INPUT)
TRG MASK	0–1000 ms	Trigger Mask specifies the time from when a trigger is received until the next trigger will be accepted.
TIME	0.0 s–10.0 s	The time after which autopan starts once it's been triggered
SPEED	0.05 Hz–40.00 Hz	Autopan speed
DIR.	Turn L, Turn R	Autopan direction
OFFSET	–180 to +180 degrees	Pan offset
HPF	THRU, 21.2 Hz–8.00 kHz	High-pass filter cutoff frequency
LPF	50.0 Hz–16.0 kHz, THRU	Low-pass filter cutoff frequency

## CHORUS 5.1

Six input, six output chorus for 5.1 surround.

Parameter	Range	Description
FREQ.	0.05–40.00 Hz	Modulation speed
AM DEPTH	0–100%	Amplitude modulation depth
PM DEPTH	0–100%	Pitch modulation depth
MOD. DLY	0.0–400.0 ms	Modulation delay time
WAVE	Sine, Tri	Modulation waveform
HPF	THRU, 21.2 Hz–8.00 kHz	High-pass filter cutoff frequency
LPF	50.0 Hz–16.0 kHz, THRU	Low-pass filter cutoff frequency
SYNC	OFF/ON	Tempo parameter sync on/off
NOTE	1	Used in conjunction with TEMPO to determine FREQ.

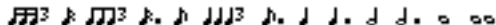
1. 

### FLANGE 5.1

Six input, six output flanger for 5.1 surround.

Parameter	Range	Description
FREQ.	0.05–40.00 Hz	Modulation speed
DEPTH	0–100%	Modulation depth
MOD. DLY	0.0–400.0 ms	Modulation delay time
FB. GAIN	–99 to +99%	Feedback gain (plus values for normal-phase feedback, minus values for reverse-phase feedback)
WAVE	Sine, Tri	Modulation waveform
HPF	THRU, 21.2 Hz–8.00 kHz	High-pass filter cutoff frequency
LPF	50.0 Hz–16.0 kHz, THRU	Low-pass filter cutoff frequency
SYNC	OFF/ON	Tempo parameter sync on/off
NOTE	<sup>1</sup>	Used in conjunction with TEMPO to determine FREQ.

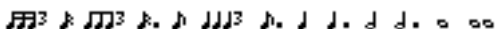
1. 

### SYMPHO 5.1

Six input, six output symphonic effect for 5.1 surround.

Parameter	Range	Description
FREQ.	0.05–40.00 Hz	Modulation speed
DEPTH	0–100%	Modulation depth
MOD. DLY	0.0–400.0 ms	Modulation delay time
WAVE	Sine, Tri	Modulation waveform
HPF	THRU, 21.2 Hz–8.00 kHz	High-pass filter cutoff frequency
LPF	50.0 Hz–16.0 kHz, THRU	Low-pass filter cutoff frequency
SYNC	OFF/ON	Tempo parameter sync on/off
NOTE	<sup>1</sup>	Used in conjunction with TEMPO to determine FREQ.

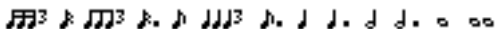
1. 



## M. BAND DYNA.

Two input, two output 3-band dynamics processor, with individual solo and gain reduction metering for each band.

Parameter	Range	Description
LOW GAIN	-96.0 to +12.0 dB	Low band level
MID GAIN	-96.0 to +12.0 dB	Mid band level
HI. GAIN	-96.0 to +12.0 dB	High band level
PRESENCE	-10 to +10	For positive values, the threshold of the high band is lowered and the threshold of the low band is increased. For negative values, the opposite will occur. When set to 0, all three bands are affected the same.
CMP. THRE	-24.0 dB to 0.0 dB	Compressor threshold
CMP. RAT	1:1 to 20:1	Compressor ratio
CMP. ATK	0-120 ms	Compressor attack
CMP. REL	1	Compressor release time
CMP. KNEE	0-5	Compressor knee
LOOKUP	0.0-100.0 ms	Lookup delay
CMP. BYP	ON/OFF	Compressor bypass
L-M XOVR	21.2 Hz-8.00 kHz	Low/mid crossover frequency
M-H XOVR	21.2 Hz-8.00 kHz	Mid/high crossover frequency
SLOPE	-6 dB, -12 dB	Filter slope
CEILING	-6.0 dB to 0.0 dB, OFF	Specifies the maximum output level
EXP. THRE	-54.0 dB to -24.0 dB	Expander threshold
EXP. RAT	1:1 to ∞:1	Expander ratio
EXP. REL	1	Expander release time
EXP. BYP	ON/OFF	Expander bypass
LIM. THRE	-12.0 dB to 0.0 dB	Limiter threshold
LIM. ATK	0-120 ms	Limiter attack
LIM. REL	1	Limiter release time
LIM. BYP	ON/OFF	Limiter bypass
LIM. KNEE	0-5	Limiter knee

1. 6.0 ms-46.0 s (fs=44.1 kHz), 5.0 ms-42.3 s (fs=48 kHz), 3 ms-23.0 s (fs=88.2 kHz), 3 ms-21.1 s (fs=96 kHz)

**COMP 5.1**

Six input, six output compressor for 5.1 surround, with individual solo for each band, and gain reduction metering of left and right (L+R), left surround and right surround (LS+RS), center (C), or LFE channels.

Parameter	Range	Description
LOW GAIN	-96.0 to +12.0 dB	Low band level
MID GAIN	-96.0 to +12.0 dB	Mid band level
HI. GAIN	-96.0 to +12.0 dB	High band level
PRESENCE	-10 to +10	For positive values, the threshold of the high band is lowered and the threshold of the low band is increased. For negative values, the opposite will occur. When set to 0, all three bands are affected the same.
THRE	-24.0 dB to 0.0 dB	Compressor threshold
RATIO	1:1 to ∞:1	Compressor ratio
ATTACK	0–120 ms	Attack
RELEASE	1	Expander release time
KNEE	0–5	Compressor knee
LOOKUP	0.0–100.0 ms	Lookup delay
KEY LINK	2	Key-in linking
L–M XOVR	21.2 Hz–8.00 kHz	Low/mid crossover frequency
M–H XOVR	21.2 Hz–8.00 kHz	Mid/high crossover frequency
SLOPE	-6 dB, -12 dB	Filter slope
CEILING	-6.0 dB to 0.0 dB, OFF	Specifies the maximum output level

- 6.0 ms–46.0 s (fs=44.1 kHz), 5.0 ms–42.3 s (fs=48 kHz), 3 ms–23.0 s (fs=88.2 kHz), 3 ms–21.1 s (fs=96 kHz)
- 5.1: key-in of all inputs are linked. 5.0: key-in of the L, C, R, LS, and RS are linked (LFE is independent). 3+2: key-in of L, C, and R are linked, and LS and RS are linked. 2+2: key-in of L and R are linked, and LS and RS are linked.

**COMPAND 5.1**

Six input, six output compander for 5.1 surround, with individual solo for each band, and gain reduction metering of left and right (L+R), left surround and right surround (LS+RS), center (C), or LFE channels.

Parameter	Range	Description
LOW GAIN	-96.0 to +12.0 dB	Low band level
MID GAIN	-96.0 to +12.0 dB	Mid band level
HI. GAIN	-96.0 to +12.0 dB	High band level
PRESENCE	-10 to +10	For positive values, the threshold of the high band is lowered and the threshold of the low band is increased. For negative values, the opposite will occur. When set to 0, all three bands are affected the same.
THRE	-24.0 dB to 0.0 dB	Compressor threshold
RATIO	1:1 to 20:1	Compressor ratio
ATTACK	0–120 ms	Compressor attack
WIDTH	1–90 dB	Width before the expander operates
TYPE	Soft, Hard	Compander type
LOOKUP	0.0–100.0 ms	Lookup delay
KEY LINK	1	Key-in linking
L–M XOVR	21.2 Hz–8.00 kHz	Low/mid crossover frequency
M–H XOVR	21.2 Hz–8.00 kHz	Mid/high crossover frequency
SLOPE	-6 dB, -12 dB	Filter slope
CEILING	-6.0 dB to 0.0 dB, OFF	Specifies the maximum output level

- 5.1: key-in of all inputs are linked. 5.0: key-in of the L, C, R, LS, and RS are linked (LFE is independent). 3+2: key-in of L, C, and R are linked, and LS and RS are linked. 2+2: key-in of L and R are linked, and LS and RS are linked.

Other preset effects (COMP276, COMP276S, COMP260, COMP260S, EQUALIZER601, OPEN-DECK, REV-X HALL, REV-X HALL, REV-X ROOM, REV-X PLATE) are optional Add-On Effects. For more information on these effects, refer to the Owner's Manual that comes with the Add-On Effects package.

## Effects and tempo synchronization

Some of the DM2000's effects allow you to synchronize the effect with the tempo. There are two such types of effect; delay-type effects and modulation-type effects. For delay-type effects, the delay time will change according to the tempo. For modulation-type effects, the frequency of the modulation signal will change according to the tempo.

### • Parameters related to tempo synchronization

The following five parameters are related to tempo synchronization.

1) SYNC 2) NOTE 3) TEMPO 4) DELAY 5) FREQ.

SYNC: ..... This is the on/off switch for tempo synchronization.

NOTE and TEMPO:..... These are the basic parameters for tempo synchronization.

DELAY and FREQ.: ..... DELAY is the delay time, and FREQ. is the frequency of the modulation signal. These directly affect the way in which the effect sound will change. DELAY is relevant only for delay-type effects, and FREQ. is relevant only for modulation-type effects.

### • How the parameters are related

Tempo synchronization uses TEMPO and NOTE to calculate a value that will be the basis for the tempo, and continues making adjustments so that this tempo basis stays essentially the same as the DELAY (or FREQ.). This means that when TEMPO, NOTE, and DELAY (or FREQ.) are synchronized, and you change any of these values, the other parameters will be re-set in order to maintain the correct relationship. The parameters that are re-set and the calculation method(\*a) used are as follows.

**If you turn SYNC on → NOTE will be set**

**If you edit DELAY (or FREQ.) → NOTE will be set**

In this case, the NOTE value is calculated as follows.

$$\text{NOTE} = \text{DELAY (or FREQ.)} / (4 \times (60/\text{TEMPO}))$$

**If you edit NOTE → DELAY (or FREQ.) will be set**

In this case, the DELAY (or FREQ.) value is calculated as follows.

$$\text{DELAY (or FREQ.)} = \text{NOTE} \times 4 \times (60/\text{TEMPO})$$

**If you edit TEMPO → DELAY (or FREQ.) will be set**

In this case, the DELAY (or FREQ.) value is calculated as follows.

$$\text{DELAY (or FREQ.)} = \text{original DELAY (or FREQ.)} \times (\text{previous TEMPO}/\text{new TEMPO})$$

Example 1: When SYNC=ON, DELAY=250 ms, TEMPO=120, you change NOTE from 8th note to quarter note

$$\begin{aligned} \text{DELAY} &= \text{new NOTE} \times 4 \times (60/\text{TEMPO}) \\ &= (1/4) \times 4 \times (60/120) \\ &= 0.5 \text{ (sec)} \\ &= 500 \text{ ms} \end{aligned}$$

Thus, the DELAY will change from 250 ms to 500 ms.

Example 2: When SYNC=ON, DELAY=250 ms, NOTE=8th note, you change TEMPO from 120 to 121

$$\begin{aligned} \text{DELAY} &= \text{original DELAY} \times (\text{previous TEMPO}/\text{new TEMPO}) \\ &= 250 \times (120/121) \\ &= 247.9 \text{ (ms)} \end{aligned}$$

Thus, the TEMPO will change from 250 ms to 247.9 ms.

\*a Rounded values are used for the calculation results.

### • Ranges of the NOTE and TEMPO values

The ranges of the NOTE and TEMPO values are limited by the ranges of the DELAY or FREQ. values. You cannot set NOTE or TEMPO values that would cause DELAY or FREQ. to exceed their maximum possible values when synchronized to tempo. This limitation also applies even when SYNC is OFF.

### • Special characteristics of the TEMPO parameter

The TEMPO parameter has the following characteristics that are unlike other parameters.















- It is a common value shared by all effects
- You cannot store it to or recall it from the Effects Library. (You can store it to and recall it from a Scene.)

This means that the TEMPO value may not necessarily be the same when an effect is recalled as when that effect was stored. Here is an example.

Store the effect: TEMPO=120 → Change TEMPO to 60 → Recall the effect: TEMPO=60

Normally when you change the TEMPO, the DELAY (or FREQ.) will be re-set accordingly. However if the DELAY (or FREQ.) were changed, the effect would sound differently when recalled than when it was stored. To prevent the effect from changing in this way between store and recall, the DM2000 does not update the DELAY (or FREQ.) value when an effect is recalled, even if the TEMPO is no longer the same as when that effect was stored.

\* The NOTE parameter is calculated based on the following values.

 = 1/48	 = 1/24	 = 1/16	 = 1/12	 = 3/32	 = 1/8	 = 1/6
 = 3/16	 = 1/4	 = 3/8	 = 1/2	 = 3/4	 = 1/1	 = 2/1

### Preset EQ Parameters

#	Title	Parameter				
		LOW	L-MID	H-MID	HIGH	
01	Bass Drum 1		PEAKING	PEAKING	PEAKING	H.SHELF
		G	+3.5 dB	-3.5 dB	0.0 dB	+4.0 dB
		F	100 Hz	265 Hz	1.06 kHz	5.30 kHz
		Q	1.2	10	0.9	—
02	Bass Drum 2		PEAKING	PEAKING	PEAKING	LPF
		G	+8.0 dB	-7.0 dB	+6.0 dB	ON
		F	80 Hz	400 Hz	2.50 kHz	12.5 kHz
		Q	1.4	4.5	2.2	—
03	Snare Drum 1		PEAKING	PEAKING	PEAKING	H.SHELF
		G	-0.5 dB	0.0 dB	+3.0 dB	+4.5 dB
		F	132 Hz	1.00 kHz	3.15 kHz	5.00 kHz
		Q	1.2	4.5	0.11	—
04	Snare Drum 2		L.SHELF	PEAKING	PEAKING	PEAKING
		G	+1.5 dB	-8.5 dB	+2.5 dB	+4.0 dB
		F	180 Hz	335 Hz	2.36 kHz	4.00 kHz
		Q	—	10	0.7	0.1
05	Tom-tom 1		PEAKING	PEAKING	PEAKING	PEAKING
		G	+2.0 dB	-7.5 dB	+2.0 dB	+1.0 dB
		F	212 Hz	670 Hz	4.50 kHz	6.30 kHz
		Q	1.4	10	1.2	0.28
06	Cymbal		L.SHELF	PEAKING	PEAKING	H.SHELF
		G	-2.0 dB	0.0 dB	0.0 dB	+3.0 dB
		F	106 Hz	425 Hz	1.06 kHz	13.2 kHz
		Q	—	8	0.9	—
07	High Hat		L.SHELF	PEAKING	PEAKING	H.SHELF
		G	-4.0 dB	-2.5 dB	+1.0 dB	+0.5 dB
		F	95 Hz	425 Hz	2.80 kHz	7.50 kHz
		Q	—	0.5	1	—
08	Percussion		L.SHELF	PEAKING	PEAKING	H.SHELF
		G	-4.5 dB	0.0 dB	+2.0 dB	0.0 dB
		F	100 Hz	400 Hz	2.80 kHz	17.0 kHz
		Q	—	4.5	0.56	—
09	E. Bass 1		L.SHELF	PEAKING	PEAKING	H.SHELF
		G	-7.5 dB	+4.5 dB	+2.5 dB	0.0 dB
		F	35.5 Hz	112 Hz	2.00 kHz	4.00 kHz
		Q	—	5	4.5	—
10	E. Bass 2		PEAKING	PEAKING	PEAKING	H.SHELF
		G	+3.0 dB	0.0 dB	+2.5 dB	+0.5 dB
		F	112 Hz	112 Hz	2.24 kHz	4.00 kHz
		Q	0.1	5	6.3	—
11	Syn. Bass 1		PEAKING	PEAKING	PEAKING	H.SHELF
		G	+3.5 dB	+8.5 dB	0.0 dB	0.0 dB
		F	85 Hz	950 Hz	4.00 kHz	12.5 kHz
		Q	0.1	8	4.5	—
12	Syn. Bass 2		PEAKING	PEAKING	PEAKING	H.SHELF
		G	+2.5 dB	0.0 dB	+1.5 dB	0.0 dB
		F	125 Hz	180 Hz	1.12 kHz	12.5 kHz
		Q	1.6	8	2.2	—

#	Title	Parameter				
		LOW	L-MID	H-MID	HIGH	
13	Piano 1		L.SHELF	PEAKING	PEAKING	H.SHELF
		G	-6.0 dB	0.0 dB	+2.0 dB	+4.0 dB
		F	95 Hz	950 Hz	3.15 kHz	7.50 kHz
		Q	—	8	0.9	—
14	Piano 2		PEAKING	PEAKING	PEAKING	H.SHELF
		G	+3.5 dB	-8.5 dB	+1.5 dB	+3.0 dB
		F	224 Hz	600 Hz	3.15 kHz	5.30 kHz
		Q	5.6	10	0.7	—
15	E. G. Clean		PEAKING	PEAKING	PEAKING	H.SHELF
		G	+2.0 dB	-5.5 dB	+0.5 dB	+2.5 dB
		F	265 Hz	400 Hz	1.32 kHz	4.50 kHz
		Q	0.18	10	6.3	—
16	E. G. Crunch 1		PEAKING	PEAKING	PEAKING	PEAKING
		G	+4.5 dB	0.0 dB	+4.0 dB	+2.0 dB
		F	140 Hz	1.00 kHz	1.90 kHz	5.60 kHz
		Q	8	4.5	0.63	9
17	E. G. Crunch 2		PEAKING	PEAKING	PEAKING	H.SHELF
		G	+2.5 dB	+1.5 dB	+2.5 dB	0.0 dB
		F	125 Hz	450 Hz	3.35 kHz	19.0 kHz
		Q	8	0.4	0.16	—
18	E. G. Dist. 1		L.SHELF	PEAKING	PEAKING	H.SHELF
		G	+5.0 dB	0.0 dB	+3.5 dB	0.0 dB
		F	355 Hz	950 Hz	3.35 kHz	12.5 kHz
		Q	—	9	10	—
19	E. G. Dist. 2		L.SHELF	PEAKING	PEAKING	H.SHELF
		G	+6.0 dB	-8.5 dB	+4.5 dB	+4.0 dB
		F	315 Hz	1.06 kHz	4.25 kHz	12.5 kHz
		Q	—	10	4	—
20	A. G. Stroke 1		PEAKING	PEAKING	PEAKING	H.SHELF
		G	-2.0 dB	0.0 dB	+1.0 dB	+4.0 dB
		F	106 Hz	1.00 kHz	1.90 kHz	5.30 kHz
		Q	0.9	4.5	3.5	—
21	A. G. Stroke 2		L.SHELF	PEAKING	PEAKING	H.SHELF
		G	-3.5 dB	-2.0 dB	0.0 dB	+2.0 dB
		F	300 Hz	750 Hz	2.00 kHz	3.55 kHz
		Q	—	9	4.5	—
22	A. G. Arpeg. 1		L.SHELF	PEAKING	PEAKING	PEAKING
		G	-0.5 dB	0.0 dB	0.0 dB	+2.0 dB
		F	224 Hz	1.00 kHz	4.00 kHz	6.70 kHz
		Q	—	4.5	4.5	0.12
23	A. G. Arpeg. 2		L.SHELF	PEAKING	PEAKING	H.SHELF
		G	0.0 dB	-5.5 dB	0.0 dB	+4.0 dB
		F	180 Hz	355 Hz	4.00 kHz	4.25 kHz
		Q	—	7	4.5	—
24	Brass Sec.		PEAKING	PEAKING	PEAKING	PEAKING
		G	-2.0 dB	-1.0 dB	+1.5 dB	+3.0 dB
		F	90 Hz	850 Hz	2.12 kHz	4.50 kHz
		Q	2.8	2	0.7	7

#	Title	Parameter				
		LOW	L-MID	H-MID	HIGH	
25	Male Vocal 1		PEAKING	PEAKING	PEAKING	PEAKING
		G	-0.5 dB	0.0 dB	+2.0 dB	+3.5 dB
		F	190 Hz	1.00 kHz	2.00 kHz	6.70 kHz
		Q	0.11	4.5	0.56	0.11
26	Male Vocal 2		PEAKING	PEAKING	PEAKING	H.SHELF
		G	+2.0 dB	-5.0 dB	-2.5 dB	+4.0 dB
		F	170 Hz	236 Hz	2.65 kHz	6.70 kHz
		Q	0.11	10	5.6	—
27	Female Vo. 1		PEAKING	PEAKING	PEAKING	PEAKING
		G	-1.0 dB	+1.0 dB	+1.5 dB	+2.0 dB
		F	118 Hz	400 Hz	2.65 kHz	6.00 kHz
		Q	0.18	0.45	0.56	0.14
28	Female Vo. 2		L.SHELF	PEAKING	PEAKING	H.SHELF
		G	-7.0 dB	+1.5 dB	+1.5 dB	+2.5 dB
		F	112 Hz	335 Hz	2.00 kHz	6.70 kHz
		Q	—	0.16	0.2	—
29	Chorus & Harmo		PEAKING	PEAKING	PEAKING	PEAKING
		G	-2.0 dB	-1.0 dB	+1.5 dB	+3.0 dB
		F	90 Hz	850 Hz	2.12 kHz	4.50 kHz
		Q	2.8	2	0.7	7
30	Total EQ 1		PEAKING	PEAKING	PEAKING	H.SHELF
		G	-0.5 dB	0.0 dB	+3.0 dB	+6.5 dB
		F	95 Hz	950 Hz	2.12 kHz	16.0 kHz
		Q	7	2.2	5.6	—
31	Total EQ 2		PEAKING	PEAKING	PEAKING	H.SHELF
		G	+4.0 dB	+1.5 dB	+2.0 dB	+6.0 dB
		F	95 Hz	750 Hz	1.80 kHz	18.0 kHz
		Q	7	2.8	5.6	—
32	Total EQ 3		L.SHELF	PEAKING	PEAKING	H.SHELF
		G	+1.5 dB	+0.5 dB	+2.0 dB	+4.0 dB
		F	67 Hz	850 Hz	1.90 kHz	15.0 kHz
		Q	—	0.28	0.7	—
33	Bass Drum 3		PEAKING	PEAKING	PEAKING	PEAKING
		G	+3.5 dB	-10.0 dB	+3.5 dB	0.0 dB
		F	118 Hz	315 Hz	4.25 kHz	20.0 kHz
		Q	2	10	0.4	0.4
34	Snare Drum 3		L.SHELF	PEAKING	PEAKING	PEAKING
		G	0.0 dB	+2.0 dB	+3.5 dB	0.0 dB
		F	224 Hz	560 Hz	4.25 kHz	4.00 kHz
		Q	—	4.5	2.8	0.1
35	Tom-tom 2		L.SHELF	PEAKING	PEAKING	H.SHELF
		G	-9.0 dB	+1.5 dB	+2.0 dB	0.0 dB
		F	90 Hz	212 Hz	5.30 kHz	17.0 kHz
		Q	—	4.5	1.2	—

#	Title	Parameter				
		LOW	L-MID	H-MID	HIGH	
36	Piano 3		PEAKING	PEAKING	PEAKING	H.SHELF
		G	+4.5 dB	-13.0 dB	+4.5 dB	+2.5 dB
		F	100 Hz	475 Hz	2.36 kHz	10.0 kHz
		Q	8	10	9	—
37	Piano Low		PEAKING	PEAKING	PEAKING	H.SHELF
		G	-5.5 dB	+1.5 dB	+6.0 dB	0.0 dB
		F	190 Hz	400 Hz	6.70 kHz	12.5 kHz
		Q	10	6.3	2.2	—
38	Piano High		PEAKING	PEAKING	PEAKING	PEAKING
		G	-5.5 dB	+1.5 dB	+5.0 dB	+3.0 dB
		F	190 Hz	400 Hz	6.70 kHz	5.60 kHz
		Q	10	6.3	2.2	0.1
39	Fine-EQ Cass		L.SHELF	PEAKING	PEAKING	H.SHELF
		G	-1.5 dB	0.0 dB	+1.0 dB	+3.0 dB
		F	75 Hz	1.00 kHz	4.00 kHz	12.5 kHz
		Q	—	4.5	1.8	—
40	Narrator		PEAKING	PEAKING	PEAKING	H.SHELF
		G	-4.0 dB	-1.0 dB	+2.0 dB	0.0 dB
		F	106 Hz	710 Hz	2.50 kHz	10.0 kHz
		Q	4	7	0.63	—

### Preset Gate Parameters (fs = 44.1 kHz)

#	Title	Type	Parameter	Value
1	Gate	GATE	Threshold (dB)	-26
			Range (dB)	-56
			Attack (ms)	0
			Hold (ms)	2.56
			Decay (ms)	331
2	Ducking	DUCKING	Threshold (dB)	-19
			Range (dB)	-22
			Attack (ms)	93
			Hold (ms)	1.20 S
			Decay (ms)	6.32 S
3	A. Dr. BD	GATE	Threshold (dB)	-11
			Range (dB)	-53
			Attack (ms)	0
			Hold (ms)	1.93
			Decay (ms)	400
4	A. Dr. SN	GATE	Threshold (dB)	-8
			Range (dB)	-23
			Attack (ms)	1
			Hold (ms)	0.63
			Decay (ms)	238

## Preset Compressor Parameters (fs = 44.1 kHz)

#	Title	Type	Parameter	Value
1	Comp	COMP	Threshold (dB)	-8
			Ratio ( :1)	2.5
			Attack (ms)	60
			Out gain (dB)	0.0
			Knee	2
			Release (ms)	250
2	Expand	EXPAND	Threshold (dB)	-23
			Ratio ( :1)	1.7
			Attack (ms)	1
			Out gain (dB)	3.5
			Knee	2
			Release (ms)	70
3	Compander (H)	COMPAND-H	Threshold (dB)	-10
			Ratio ( :1)	3.5
			Attack (ms)	1
			Out gain (dB)	0.0
			Width (dB)	6
			Release (ms)	250
4	Compander (S)	COMPAND-S	Threshold (dB)	-8
			Ratio ( :1)	4
			Attack (ms)	25
			Out gain (dB)	0.0
			Width (dB)	24
			Release (ms)	180
5	A. Dr. BD	COMP	Threshold (dB)	-24
			Ratio ( :1)	3
			Attack (ms)	9
			Out gain (dB)	5.5
			Knee	2
			Release (ms)	58
6	A. Dr. BD	COMPAND-H	Threshold (dB)	-11
			Ratio ( :1)	3.5
			Attack (ms)	1
			Out gain (dB)	-1.5
			Width (dB)	7
			Release (ms)	192
7	A. Dr. SN	COMP	Threshold (dB)	-17
			Ratio ( :1)	2.5
			Attack (ms)	8
			Out gain (dB)	3.5
			Knee	2
			Release (ms)	12
8	A. Dr. SN	EXPAND	Threshold (dB)	-23
			Ratio ( :1)	2
			Attack (ms)	0
			Out gain (dB)	0.5
			Knee	2
			Release (ms)	151
9	A. Dr. SN	COMPAND-S	Threshold (dB)	-8
			Ratio ( :1)	1.7
			Attack (ms)	11
			Out gain (dB)	0.0
			Width (dB)	10
			Release (ms)	128
10	A. Dr. Tom	EXPAND	Threshold (dB)	-20
			Ratio ( :1)	2
			Attack (ms)	2
			Out gain (dB)	5.0
			Knee	2
			Release (ms)	749
11	A. Dr. OverTop	COMPAND-S	Threshold (dB)	-24
			Ratio ( :1)	2
			Attack (ms)	38
			Out gain (dB)	-3.5
			Width (dB)	54
			Release (ms)	842
12	E. B. Finger	COMP	Threshold (dB)	-12
			Ratio ( :1)	2
			Attack (ms)	15
			Out gain (dB)	4.5
			Knee	2
			Release (ms)	470
13	E. B. Slap	COMP	Threshold (dB)	-12
			Ratio ( :1)	1.7
			Attack (ms)	6
			Out gain (dB)	4.0
			Knee	hard
			Release (ms)	133
14	Syn. Bass	COMP	Threshold (dB)	-10
			Ratio ( :1)	3.5
			Attack (ms)	9
			Out gain (dB)	3.0
			Knee	hard
			Release (ms)	250
15	Piano1	COMP	Threshold (dB)	-9
			Ratio ( :1)	2.5
			Attack (ms)	17
			Out gain (dB)	1.0
			Knee	hard
			Release (ms)	238
16	Piano2	COMP	Threshold (dB)	-18
			Ratio ( :1)	3.5
			Attack (ms)	7
			Out gain (dB)	6.0
			Knee	2
			Release (ms)	174
17	E. Guitar	COMP	Threshold (dB)	-8
			Ratio ( :1)	3.5
			Attack (ms)	7
			Out gain (dB)	2.5
			Knee	4
			Release (ms)	261
18	A. Guitar	COMP	Threshold (dB)	-10
			Ratio ( :1)	2.5
			Attack (ms)	5
			Out gain (dB)	1.5
			Knee	2
			Release (ms)	238

#	Title	Type	Parameter	Value
19	Strings1	COMP	Threshold (dB)	-11
			Ratio ( :1)	2
			Attack (ms)	33
			Out gain (dB)	1.5
			Knee	2
			Release (ms)	749
20	Strings2	COMP	Threshold (dB)	-12
			Ratio ( :1)	1.5
			Attack (ms)	93
			Out gain (dB)	1.5
			Knee	4
			Release (ms)	1.35 S
21	Strings3	COMP	Threshold (dB)	-17
			Ratio ( :1)	1.5
			Attack (ms)	76
			Out gain (dB)	2.5
			Knee	2
			Release (ms)	186
22	BrassSection	COMP	Threshold (dB)	-18
			Ratio ( :1)	1.7
			Attack (ms)	18
			Out gain (dB)	4.0
			Knee	1
			Release (ms)	226
23	Syn. Pad	COMP	Threshold (dB)	-13
			Ratio ( :1)	2
			Attack (ms)	58
			Out gain (dB)	2.0
			Knee	1
			Release (ms)	238
24	SamplingPerc	COMPAND-S	Threshold (dB)	-18
			Ratio ( :1)	1.7
			Attack (ms)	8
			Out gain (dB)	-2.5
			Width (dB)	18
			Release (ms)	238
25	Sampling BD	COMP	Threshold (dB)	-14
			Ratio ( :1)	2
			Attack (ms)	2
			Out gain (dB)	3.5
			Knee	4
			Release (ms)	35
26	Sampling SN	COMP	Threshold (dB)	-18
			Ratio ( :1)	4
			Attack (ms)	8
			Out gain (dB)	8.0
			Knee	hard
			Release (ms)	354
27	Hip Comp	COMPAND-S	Threshold (dB)	-23
			Ratio ( :1)	20
			Attack (ms)	15
			Out gain (dB)	0.0
			Width (dB)	15
			Release (ms)	163

#	Title	Type	Parameter	Value
28	Solo Vocal1	COMP	Threshold (dB)	-20
			Ratio ( :1)	2.5
			Attack (ms)	31
			Out gain (dB)	2.0
			Knee	1
			Release (ms)	342
29	Solo Vocal2	COMP	Threshold (dB)	-8
			Ratio ( :1)	2.5
			Attack (ms)	26
			Out gain (dB)	1.5
			Knee	3
			Release (ms)	331
30	Chorus	COMP	Threshold (dB)	-9
			Ratio ( :1)	1.7
			Attack (ms)	39
			Out gain (dB)	2.5
			Knee	2
			Release (ms)	226
31	Click Erase	EXPAND	Threshold (dB)	-33
			Ratio ( :1)	2
			Attack (ms)	1
			Out gain (dB)	2.0
			Knee	2
			Release (ms)	284
32	Announcer	COMPAND-H	Threshold (dB)	-14
			Ratio ( :1)	2.5
			Attack (ms)	1
			Out gain (dB)	-2.5
			Width (dB)	18
			Release (ms)	180
33	Limiter1	COMPAND-S	Threshold (dB)	-9
			Ratio ( :1)	3
			Attack (ms)	20
			Out gain (dB)	-3.0
			Width (dB)	90
			Release (ms)	3.90 s
34	Limiter2	COMP	Threshold (dB)	0
			Ratio ( :1)	∞
			Attack (ms)	0
			Out gain (dB)	0.0
			Knee	hard
			Release (ms)	319
35	Total Comp1	COMP	Threshold (dB)	-18
			Ratio ( :1)	3.5
			Attack (ms)	94
			Out gain (dB)	2.5
			Knee	hard
			Release (ms)	447
36	Total Comp2	COMP	Threshold (dB)	-16
			Ratio ( :1)	6
			Attack (ms)	11
			Out gain (dB)	6.0
			Knee	1
			Release (ms)	180

## Dynamics Parameters

The dynamics effects for each channel strip include a Gate section (only for Input Channels) and a Comp section. The Gate section includes Gate and Ducking types. The Comp section includes Compressor, Expander, Compressor Hard (COMP. (H)), and Compressor Soft (COMP. (S)) types.

### GATE Section (Only for Input Channels)

#### GATE

A gate attenuates signals below a set THRESHOLD level by a specified amount (RANGE).

Parameter	Range	Description
THRESHOLD (dB)	-54.0 to 0.0 (541 points)	This determines the level at which the gate effect is applied.
RANGE (dB)	-70 to 0 (71 points)	This determines the amount of attenuation when the gate closes.
ATTACK (ms)	0-120 (121 points)	This determines how fast the gate opens when the signal exceeds the threshold level.
HOLD (ms)	44.1kHz: 0.02 ms – 2.13 sec 48kHz: 0.02 ms – 1.96 sec 88.2kHz: 0.01 ms – 1.06 sec 96kHz: 0.01 ms – 981 ms (160 points)	This determines how long the gate stays open once the trigger signal has fallen below the threshold.
DECAY (ms)	44.1kHz: 6 ms – 46.0 sec 48kHz: 5 ms – 42.3 sec 88.2kHz: 3 ms – 23.0 sec 96kHz: 3 ms – 21.1 sec (160 points)	This determines how fast the gate closes once the hold time has expired. The value is expressed as the duration required for the level to change by 6 dB.

I/O Characteristics

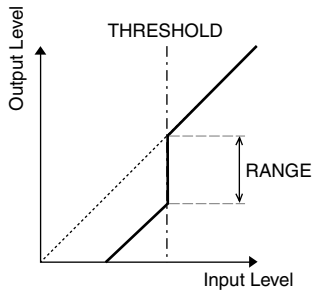

Time Series Analysis

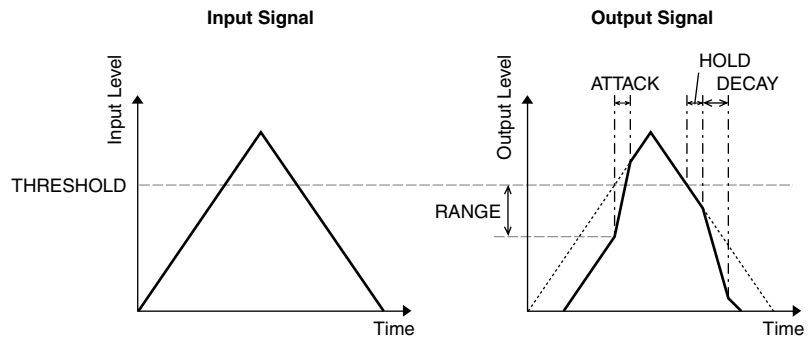



### DUCKING

Ducking is commonly used for voice-over applications in which the background music level is reduced automatically when an announcer speaks. When the KEY IN source signal level exceeds the specified THRESHOLD, the output level is attenuated by a specified amount (RANGE).

Parameter	Range	Description
<b>THRESHOLD (dB)</b>	-54.0 to 0.0 (541 points)	This determines the level of trigger signal (KEY IN) required to activate ducking.
<b>RANGE (dB)</b>	-70 to 0 (71 points)	This determines the amount of attenuation when ducking is activated.
<b>ATTACK (ms)</b>	0-120 (121 points)	This determines how soon the signal is ducked once the ducker has been triggered.
<b>HOLD (ms)</b>	44.1kHz: 0.02 ms – 2.13 sec 48kHz: 0.02 ms – 1.96 sec 88.2kHz: 0.01 ms – 1.06 sec 96kHz: 0.01 ms – 981 ms (160 points)	This determines how long ducking remains active once the trigger signal has fallen below the THRESHOLD level.
<b>DECAY (ms)</b>	44.1kHz: 6 ms – 46.0 sec 48kHz: 5 ms – 42.3 sec 88.2kHz: 3 ms – 23.0 sec 96kHz: 3 ms – 21.1 sec (160 points)	This determines how soon the ducker returns to its normal gain once the trigger signal level drops below the threshold. The value is expressed as the duration required for the level to change by 6 dB.

I/O Characteristics

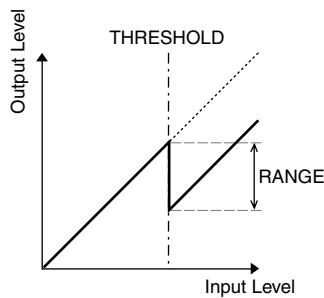

Time Series Analysis

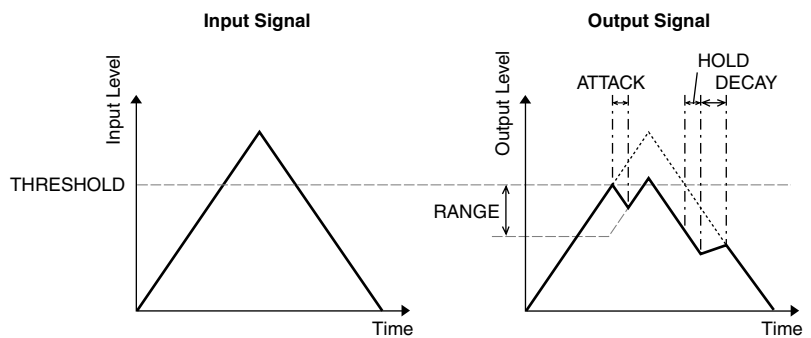

## COMP Section

### COMP

The COMP processor attenuates signals above a specified THRESHOLD by a specified RATIO. The COMP processor can also be used as a limiter, which, with a RATIO of  $\infty:1$ , reduces the level to the threshold. This means that the limiter's output level never actually exceeds the threshold.

Parameter	Range	Description
THRESHOLD (dB)	-54.0 to 0.0 (541 points)	This determines the level of input signal required to trigger the compressor.
RATIO	1.0:1, 1.1:1, 1.3:1, 1.5:1, 1.7:1, 2.0:1, 2.5:1, 3.0:1, 3.5:1, 4.0:1, 5.0:1, 6.0:1, 8.0:1, 10:1, 20:1, $\infty:1$ (16 points)	This determines the amount of compression, that is, the change in output signal level relative to change in input signal level.
ATTACK (ms)	0-120 (121 points)	This determines how soon the signal will be compressed once the compressor has been triggered.
RELEASE (ms)	44.1kHz: 6 ms – 46.0 sec 48kHz: 5 ms – 42.3 sec 88.2kHz: 3 ms – 23.0 sec 96kHz: 3 ms – 21.1 sec (160 points)	This determines how soon the compressor returns to its normal gain once the trigger signal level drops below the threshold. The value is expressed as the duration required for the level to change by 6 dB.
OUT GAIN (dB)	0.0 to +18.0 (180 points)	This sets the compressor's output signal level.
KNEE	Hard, 1-5 (6 points)	This determines how compression is applied at the threshold. For higher knee settings, compression is applied gradually as the signal exceeds the specified threshold, creating a more natural sound.

I/O Characteristics  
(KNEE=hard, OUT GAIN=0.0dB)

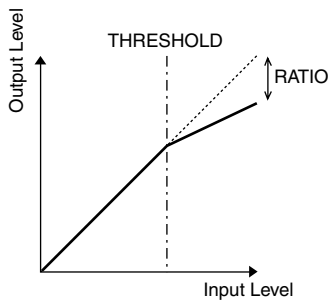

Time Series Analysis (RATIO= $\infty:1$ )

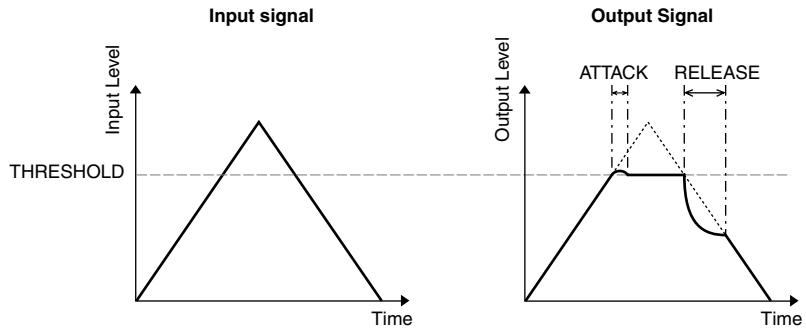

### EXPAND

An expander attenuates signals below a specified THRESHOLD by a specified RATIO.

Parameter	Range	Description
THRESHOLD (dB)	-54.0 to 0.0 (541 points)	This determines the level of input signal required to trigger the expander.
RATIO	1.0:1, 1.1:1, 1.3:1, 1.5:1, 1.7:1, 2.0:1, 2.5:1, 3.0:1, 3.5:1, 4.0:1, 5.0:1, 6.0:1, 8.0:1, 10:1, 20:1, ∞:1 (16 points)	This determines the amount of expansion.
ATTACK (ms)	0-120 (121 points)	This determines how soon the expander returns to its normal gain once the trigger signal level exceeds the threshold.
RELEASE (ms)	44.1kHz: 6 ms - 46.0 sec 48kHz: 5 ms - 42.3 sec 88.2kHz: 3 ms - 23.0 sec 96kHz: 3 ms - 21.1 sec (160 points)	This determines how soon the signal is expanded once the signal level drops below the threshold. The value is expressed as the duration required for the level to change by 6 dB.
OUT GAIN (dB)	0.0 to +18.0 (180 points)	This sets the expander's output signal level.
KNEE	Hard, 1-5 (6 points)	This determines how expansion is applied at the threshold. For higher knee settings, expansion is applied gradually as the signal falls below the specified threshold, creating a more natural sound.

I/O Characteristics  
(KNEE=hard, OUT GAIN=0.0dB)

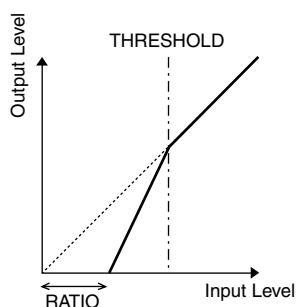

Time Series Analysis (RATIO=∞:1)

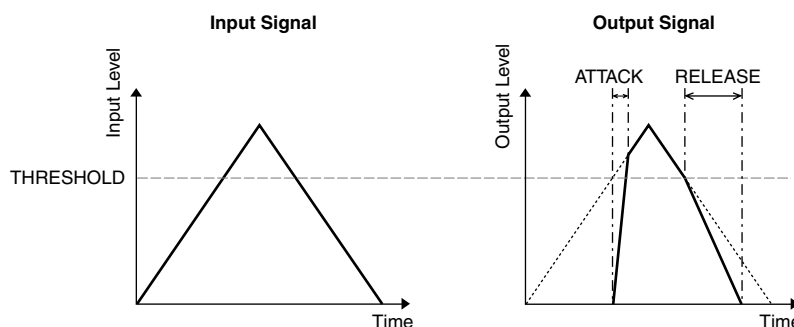

**COMPANDER HARD (H)  
COMPANDER SOFT (S)**

The hard and soft companders combine the effects of the compressor, expander and limiter.

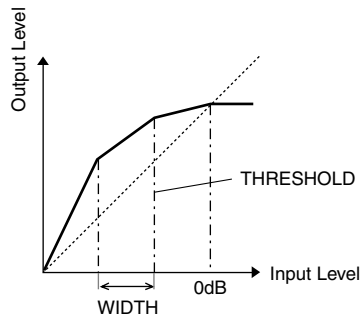

The companders function differently at the following levels:

- ① 0 dB and higher .....Functions as a limiter.
- ② Exceeding the threshold .....Functions as a compressor.
- ③ Below the threshold and width .....Functions as an expander.

The hard compander has an expansion ratio of 5:1, while the soft compander has an expansion ratio of 1.5:1. The expander is essentially turned off when the width is set to maximum. The compressor has a fixed knee setting of 2.

- \* The gain is automatically adjusted according to the ratio and threshold values, and can be increased by up to 18 dB.
- \* The OUT GAIN parameter enables you to compensate for the overall level change caused by the compression and expansion processes.

Parameter	Range	Description
<b>THRESHOLD (dB)</b>	-54.0 to 0.0 (541 points)	This determines the level at which compression is applied.
<b>RATIO</b>	1.0:1, 1.1:1, 1.3:1, 1.5:1, 1.7:1, 2.0:1, 2.5:1, 3.0:1, 3.5:1, 4.0:1, 5.0:1, 6.0:1, 8.0:1, 10:1, 20:1, (15 points)	This determines the amount of compression.
<b>ATTACK (ms)</b>	0-120 (121 points)	This determines how soon the signal is compressed or expanded once the compander has been triggered.
<b>RELEASE (ms)</b>	44.1kHz: 6 ms – 46.0 sec 48kHz: 5 ms – 42.3 sec 88.2kHz: 3 ms – 23.0 sec 96kHz: 3 ms – 21.1 sec (160 points)	This determines how soon the compressor or expander returns to the normal gain once the trigger signal level drops below or exceeds the threshold respectively. The value is expressed as the duration required for the level to change by 6 dB.
<b>OUT GAIN (dB)</b>	-18.0 to 0.0 (180 points)	This sets the compander's output signal level.
<b>WIDTH (dB)</b>	0-90 (91 points)	This determines how far below the threshold expansion will be applied. The expander is activated when the level drops below the threshold and width.

# Appendix B: Specifications

## General Spec

Number of scene memories		99
Sampling Frequency	Internal	44.1 kHz, 48 kHz, 88.2 kHz, 96 kHz
	External	Normal rate: 44.1 kHz–10% to 48 kHz+6%
Double rate: 88.2 kHz–10% to 96 kHz+6%		
Signal Delay		Less than 2.3 ms CH INPUT to STEREO OUT (fs=48 kHz)
		Less than 1.2 ms CH INPUT to STEREO OUT (fs=96 kHz)
Fader		100 mm motorized with touch sense × 25
Fader Resolution		+10 to –138, –∞dB input faders (10bit fader data)
		0 to –138, –∞dB master fader (10bit fader data)
Total Harmonic Distortion <sup>1</sup> (CH INPUT to STEREO OUT) (Input Gain=Min.)	fs=48 kHz	Less than 0.05% 20 Hz to 20 kHz @ +14 dB into 600 Ω Less than 0.01% 1 kHz @ +18 dB into 600 Ω
	fs=96 kHz	Less than 0.05% 20 Hz to 40 kHz @ +14 dB into 600 Ω Less than 0.01% 1 kHz @ +18 dB into 600 Ω
Frequency Response (CH INPUT to STEREO OUT)		20 Hz–20 kHz, 0.5, –1.5 dB @ +4 dB into 600 Ω (fs=48 kHz)
		20 Hz–40 kHz, 0.5, –1.5 dB @ +4 dB into 600 Ω (fs=96 kHz)
Dynamic Range (maximum level to noise level)		110 dB typ. DA Converter (STEREO OUT)
		108 dB typ. AD+DA (to STEREO OUT) @ fs=48 kHz
		106 dB typ. AD+DA (to STEREO OUT) @ fs=96 kHz
Hum & Noise <sup>2</sup> (20 Hz–20 kHz) Rs=150 Ω Input Gain=Max. Input Pad =0 dB		–128 dB Equivalent Input Noise
		–92 dB residual output noise. STEREO OUT (STEREO OUT off)
		–92 dB (96 dB S/N) STEREO OUT (STEREO fader at nominal level and all CH INPUT faders at minimum level)
		–64 dB (68 dB S/N) STEREO OUTPUT (STEREO fader at nominal level and one CH INPUT fader at nominal level)
Maximum Voltage Gain		74 dB CH INPUT (CH1–24) to STEREO OUT/OMNI (BUS) OUT
		74 dB CH INPUT (CH1–24) to OMNI (AUX) OUT (via pre input fader)
		74 dB CH INPUT (CH1–24) to CONTROL ROOM MONITOR OUT (via STEREO bus)
Crosstalk (@ 1 kHz) Input Gain=Min.		–80 dB adjacent input channels (CH1–24)
		–80 dB input to output
AD Input (1–24: A/B)	Phantom switch	+48 V DC is supplied to A (XLR-3-31 type) input
	Pad switch	0/26 dB attenuation
	Gain control	44 dB (–60 to –16), detented
	Peak indicator	LED (red) turns on when post HA level reaches 3 dB below clipping
	Signal indicator	LED (green) turns on when post HA level reaches 20 dB below nominal
	Insert	OUT, IN (pre AD converter)
	Insert switch	on/off
AD converter	24-bit linear, 128-times oversampling (fs=48 kHz)	
Analog Input (2TR IN ANALOG 1, 2)	AD converter	24-bit linear, 128-times oversampling (fs=48 kHz)
Option Input (SLOT 1–6)	Available cards	Optional digital interface cards (MY16, MY8, MY4 series)
Digital Input (2TR IN DIGITAL 1–3)	SRC	On/off (1:3 and 3:1 maximum input to output sample rate ratio)

Input Channel CH1–96	Input patch	—	
	Phase	Normal/reverse	
	Gate-type <sup>3</sup>	On/off	Key in: 12 ch Group (1–12, 13–24, 25–36, 37–48, 49–60, 61–72, 73–84, 85–96)/AUX1–12
		Comp-type <sup>4</sup>	On/off Key in: self /Stereo Link Pre EQ/pre fader/post fader
	Attenuator	–96.0 to +12.0 dB (0.1 dB step)	
	EQ	4-band PEQ <sup>5</sup>	
		On/off	
	Delay	0–43400 samples	
	On/off	—	
	Fader	100 mm motorized (INPUT/AUX1–12)	
	Aux send	On/off	AUX1–12; pre fader/post fader
		Solo	On/off Pre fader/after pan
	Pan	127 positions (Left= 1–63, Center, Right= 1–63)	
	Surround pan	127 × 127 positions	
	LFE level	–∞, –96 dB to +10 dB (256 step)	
	Routing	STEREO, BUS1–8, DIRECT OUT	
	Direct out	Pre EQ/pre fader/post fader	
	Metering	Displayed on LCD	
		Peak hold on/off	
TALKBACK	Level control	Analog rotary potentiometer	
	AD converter	24-bit linear, 128-times oversampling	
	Talkback select	Built-in microphone/AD IN 1–24	
	On/off	—	
	Slate	On/off	
OSCILLATOR	Level	0 to –96 dB (1 dB step)	
	On/off	—	
	Waveform	Sine 100 Hz, sine 1 kHz, sine 10 kHz, pink noise, burst noise	
	Routing	BUS1–8, AUX1–12, MATRIX 1L–4R, STEREO L, R	
STEREO OUT	DA converter	24-bit linear, 128-times oversampling	
OMNI OUT 1–8	Output patch	SURROUND MONITOR, STEREO, BUS1–8, AUX1–12, MATRIX 1L–4R, DIRECT OUT 1–96, INSERT OUT (CH1–96, BUS1–8, AUX1–12, MATRIX 1L–4R, STEREO)	
	DA converter	24-bit linear, 128-times oversampling	
CONTROL ROOM MONITOR OUT (LARGE, SMALL)	Monitor select	STEREO, 2TR IN DIGITAL 1, 2TR IN DIGITAL 2, 2TR IN DIGITAL 3, 2TR IN ANALOG 1, 2TR IN ANALOG 2, ASSIGN 1, 2 (BUS 1–8)/AUX 1–12/MATRIX 1–4)	
	Solo contrast	–96 to 0 dB (1 dB step)	
	Mono	On/off	
	Dimmer	On/off	
	DA converter	24-bit linear, 128-times oversampling	
	Level control	Analog rotary potentiometer	
	Phones level	Analog rotary potentiometer	
	Small trim	Analog rotary potentiometer	
STUDIO MONITOR OUT	Monitor select	CONTROL ROOM, STEREO, AUX 11, AUX 12	
	DA converter	24-bit linear, 128-times oversampling	
	Level control	Analog rotary potentiometer	
2TR OUT DIGITAL 1–3	Dither	On/off	
		Word length 16, 20, 24-bit	
	Output patch	STEREO, BUS1–8, AUX 1–12, MATRIX 1L–4R, DIRECT OUT 1–96, INSERT OUT, CONTROL ROOM	
	SRC	On/off (1:3 and 3:1 maximum input to output sample rate ratio)	

Option Output (SLOT 1–6)	Available card	Optional digital interface card (MY16, MY8, MY4 series)
	Output patch	SURROUND MONITOR, STEREO, BUS1–8, AUX1–12, MATRIX 1L–4R, DIRECT OUT 1–96, INSERT OUT (CH1–96, BUS1–8, AUX1–12, MATRIX 1L–4R, STEREO)
	Dither	On/off Word length 16/20/24-bit
Memory card slot		SmartMedia
STEREO	Comp-type <sup>4</sup>	On/off
		Pre EQ/pre fader/post fader
	Attenuator	–96.0 to +12.0 dB (0.1 dB step)
	EQ	4-band PEQ <sup>5</sup>
		On/off
	On/off	
	Fader	100 mm motorized
	Balance	127 positions (Left=1–63, Center, Right=1–63)
	Delay	0–43400 samples
	Matrix send	Pre fader/post fader
		Level (–∞, –96 dB to +10 dB)
Pan: 127 positions (Left=1–63, Center, Right=1–63)		
Metering	Displayed on LCD	
	Peak hold on/off	
BUS1–8	Comp-type <sup>4</sup>	On/off
		Pre EQ/pre fader/post fader
	Attenuator	–96.0 to +12.0 dB (0.1 dB step)
	EQ	4-band PEQ <sup>5</sup>
		On/off
	On/off	—
	Fader	100 mm motorized
	Delay	0–43400 samples
	Matrix send	Pre fader/post fader
		Level (–∞, –96 dB to +10 dB)
		Pan: 127 positions (Left=1–63, Center, Right=1–63)
	Bus to stereo	Level (–∞, –130 dB to 0 dB)
		On/off
	Metering	Pan: 127 positions (Left=1–63, Center, Right=1–63)
Displayed on LCD		
	Peak hold on/off	
AUX1–12	Comp-type <sup>4</sup>	On/off
		Pre EQ/pre fader/post fader
	Attenuator	–96.0 to +12.0 dB (0.1 dB step)
	EQ	4-band PEQ <sup>5</sup>
		On/off
	On/off	—
	Fader	100 mm motorized
	Delay	0–43400 samples
	Matrix send	Pre fader/post fader
		Level (–∞, –96 dB to +10 dB)
		Pan: 127 positions (Left=1–63, Center, Right=1–63)
Metering	Displayed on LCD	
	Peak hold on/off	

MATRIX 1L-4R	Comp-type <sup>4</sup>	On/off Pre EQ/pre fader/post fader
	Attenuator	-96.0 to +12.0 dB (0.1 dB step)
	EQ	4-band PEQ <sup>5</sup> On/off
	On/off	—
	Fader	100 mm motorized
	Balance	127 positions (Left=1-63, Center, Right=1-63)
	Delay	0-43400 samples
	Metering	Displayed on LCD Peak hold on/off
SURROUND MONITOR	Mute	On/off
	Solo	On/off
	Source	BUS1-8, SLOT 1-6
	Monitor to C-R	On/off
	Oscillator	Pink noise/500-2 kHz/1 kHz
	Monitor matrix	6.1→6.1, 6.1→5.1, 6.1→3-1, 6.1→ST, 5.1→5.1, 5.1→3-1, 5.1→ST, 3.1→3.1, 3.1→ST
	Bass management	5 presets
	Monitor alignment	ATT (-12.0 dB to 12 dB 0.1 dB step), Delay (0-30.0 msec, 0.01 msec step)
INTERNAL EFFECTS (EFFECT 1-8)	Bypass	On/off
	In/out	8-in, 8-out (EFFECT1-2): depends on effects type 2-in, 2-out (EFFECT3-8): depends on effects type
	Effect-in from	AUX1-12/INSERT OUT/effect-out
	Effect-out to	Input patch/effect-in
GRAPHIC EQUALIZERS (GEQ 1-6)	On/off	—
	Band number	31
	Limit	±15 dB, ±12 dB, ±6 dB, -24 dB
	Insert position	BUS1-8/AUX1-12/STEREO L, R/MATRIX 1L-4R
Power Requirements	U.S./Canada	120 V, 60 Hz 300 W
	Other	220-240 V, 50/60 Hz 300 W
Dimensions	(H x D x W)	257 x 821 x 906 mm (10.1" x 32.3" x 35.7")
Net weight		43 kg (94.8 lbs)
Operating free-air temperature range		10-35°C (50-95°F)
Storage temperature range		-20 to 60°C (-4 to 140°F)
Supplied Accessories		AC Cable CD-ROM (Studio Manager)
Options		Digital interface card (MY16, MY8, MY4 series) PEAK METER BRIDGE: MB2000 SIDE PANEL: SP2000

1. Total harmonic distortion is measured with a 6 dB/octave filter @ 80 kHz.
2. Hum & Noise are measured with a 6 dB/octave filter @ 12.7 kHz; equivalent to a 20 kHz filter with infinite dB/octave attenuation.
3. See "Gate Parameters" on page 345.
4. See "Comp Parameters" on page 345.
5. See "EQ Parameters" on page 345.



### EQ Parameters

	LOW/HPF	L-MID	H-MID	HIGH /LPF
Q	0.1–10.0 (41 points) low shelving HPF	0.1–10.0 (41 points)		0.1–10.0 (41 points) high shelving LPF
F	21.2 Hz–20 kHz (1/12 oct step)			
G	±18 dB (0.1 dB step) HPF: on/off	±18 dB (0.1 dB step)		±18 dB (0.1 dB step) LPF: on/off

### Gate Parameters

Gate	Threshold	–54 dB to 0 dB (0.1 dB step)
	Range	–70 dB to 0 dB (1 dB step)
	Attack	0 ms–120 ms (1 ms step)
	Hold	0.02 ms–1.96 s (216 points) @ 48 kHz
		0.02 ms–2.13 s (216 points) @ 44.1 kHz
		0.01 ms–981 ms (216 points) @ 96 kHz
		0.01 ms–1.06 s (216 points) @ 88.2 kHz
	Decay	5 ms–42.3 s (160 points) @ 48 kHz
		6 ms–46.0 s (160 points) @ 44.1 kHz
		3 ms–21.1 s (160 points) @ 96 kHz
3 ms–23.0 s (160 points) @ 88.2 kHz		
Ducking	Threshold	–54 dB to 0 dB (0.1 dB step)
	Range	–70 dB to 0 dB (1 dB step)
	Attack	0 ms–120 ms (1 ms step)
	Hold	0.02 ms–1.96 s (216 points) @ 48 kHz
		0.02 ms–2.13 s (216 points) @ 44.1 kHz
		0.01 ms–981 ms (216 points) @ 96 kHz
		0.01 ms–1.06 s (216 points) @ 88.2 kHz
	Decay	5 ms–42.3 s (160 points) @ 48 kHz
		6 ms–46.0 s (160 points) @ 44.1 kHz
		3 ms–21.1 s (160 points) @ 96 kHz
3 ms–23.0 s (160 points) @ 88.2 kHz		

### Comp Parameters

Compressor	Threshold	–54 dB to 0 dB (0.1 dB step)
	Ratio (x :1)	x=1, 1.1, 1.3, 1.5, 1.7, 2, 2.5, 3, 3.5, 4, 5, 6, 8, 10, 20, ∞ (16 points)
	Out gain	0 dB to +18 dB (0.1 dB step)
	Knee	Hard, 1, 2, 3, 4, 5 (6 step)
	Attack	0 ms–120 ms (1 ms step)
	Release	5 ms–42.3 s (160 points) @ 48 kHz
		6 ms–46.0 s (160 points) @ 44.1 kHz
		3 ms–21.1 s (160 points) @ 96 kHz
		3 ms–23.0 s (160 points) @ 88.2 kHz
	Expander	Threshold
Ratio (x :1)		x=1, 1.1, 1.3, 1.5, 1.7, 2, 2.5, 3, 3.5, 4, 5, 6, 8, 10, 20, ∞ (16 points)
Out gain		0 dB to +18 dB (0.1 dB step)
Knee		Hard, 1, 2, 3, 4, 5 (6 points)
Attack		0 ms–120 ms (1 ms step)
Release		5 ms–42.3 s (160 points) @ 48 kHz
		6 ms–46.0 s (160 points) @ 44.1 kHz
		3 ms–21.1 s (160 points) @ 96 kHz
	3 ms–23.0 s (160 points) @ 88.2 kHz	

Compander H	Threshold	-54 dB to 0 dB (0.1 dB step)	
	Ratio (x :1)	x=1, 1.1, 1.3, 1.5, 1.7, 2, 2.5, 3, 3.5, 4, 5, 6, 8, 10, 20, ∞ (16 points)	
	Out gain	-18 dB to 0 dB (0.1 dB step)	
	Width	1 dB-90 dB (1 dB step)	
	Attack	0 ms-120 ms (1 ms step)	
	Release		5 ms-42.3 s (160 points) @ 48 kHz
			6 ms-46.0 s (160 points) @ 44.1 kHz
		3 ms-21.1 s (160 points) @ 96 kHz	
		3 ms-23.0 s (160 points) @ 88.2 kHz	
Compander S	Threshold	-54 dB to 0 dB (0.1 dB step)	
	Ratio (x :1)	x=1, 1.1, 1.3, 1.5, 1.7, 2, 2.5, 3, 3.5, 4, 5, 6, 8, 10, 20 (15 points)	
	Out gain	-18 dB to 0 dB (0.1 dB step)	
	Width	1 dB-90 dB (1 dB step)	
	Attack	0 ms-120 ms (1 ms step)	
	Release		5 ms-42.3 s (160 points) @ 48 kHz
			6 ms-46.0 s (160 points) @ 44.1 kHz
		3 ms-21.1 s (160 points) @ 96 kHz	
		3 ms-23.0 s (160 points) @ 88.2 kHz	

## Libraries

Effect library (EFFECT 1-8)	Presets	61 (EFFECT 3-8: 53) <sup>1</sup>
	User memories	67
Compressor library	Presets	36
	User memories	92
Gate library	Presets	4
	User memories	124
EQ library	Presets	40
	User memories	160
Channel library	Presets	2
	User memories	127
GEQ library (GEQ 1-6)	Presets	1
	User memories	128
Surround Monitor library	Presets	1
	User memories	32
Input patch library	Presets	1
	User memories	32
Output patch library	Presets	1
	User memories	32
Bus to Stereo library	Presets	1
	User memories	32

1. Effects #53-61 are Add-On Effects.

## Analog Input Spec

Input	PAD	GAIN	Actual Load Impedance	For Use With Nominal	Input level			Connector
					Sensitivity <sup>1</sup>	Nominal	Max. before clip	
INPUT A/B 1–24	0	–60 dB	3k $\Omega$	50–600 $\Omega$ Mics & 600 $\Omega$ Lines	–70 dB (0.245 mV)	–60 dB (0.775 mV)	–46 dB (3.88 mV)	A: XLR-3-31 type (Balanced) <sup>2</sup>
		–16 dB			–26 dB (38.8 mV)	–16 dB (0.123 V)	–2 dB (616 mV)	B: Phone jack (TRS) (Balanced) <sup>3</sup>
	26	0dB (775 mV)			+10 dB (2.45 V)	+24 dB (12.28 V)		
INSERT IN 1–24	—	—	10K $\Omega$	600 $\Omega$ Lines	–6dB (388 mV)	+4 dB (1.23 V)	+18 dB (6.16 V)	Phone jack (TRS) (Balanced) <sup>3</sup>
2TR IN ANALOG 1 [L, R]	—	—	10K $\Omega$	600 $\Omega$ Lines	+4 dB (1.23 V)	+4 dB (1.23 V)	+18 dB (6.16 V)	Phone jack (TRS) (Balanced) <sup>3</sup>
2TR IN ANALOG 2 [L, R]	—	—	10K $\Omega$	600 $\Omega$ Lines	–10 dBV (0.316 V)	–10 dBV (0.316 V)	+4 dBV (1.58 V)	Phono (Unbalanced)

1. Sensitivity is the lowest level that will produce an output of +4 dB (1.23 V) or the nominal output level when the unit is set to maximum gain. (All faders and level controls are maximum position.)
2. XLR-3-31 type connectors are balanced (1=GND, 2=HOT, 3=COLD).
3. Phone jacks are balanced (Tip=HOT, Ring=COLD, Sleeve=GND).

In these specifications, when dB represents a specific voltage, 0 dB is referenced to 0.775 Vrms.

For 2TR IN ANALOG 2 levels, 0 dBV is referenced to 1.00 Vrms.

All input AD converters (except INSERT IN 1–24) are 24-bit linear, 128-times oversampling.

+48 V DC (phantom power) is supplied to CH INPUT (1–24) XLR type connectors via individual switches.

## Analog Output Spec

Output	Actual Source Impedance	For Use With Nominal	GAIN SW <sup>1</sup>	Output level		Connector
				Nominal	Max. before clip	
STEREO OUT [L, R]	600 $\Omega$	10k $\Omega$ Lines	—	–10 dBV (0.316 V)	+4 dBV (1.58 V)	Phono (Unbalanced)
	75 $\Omega$	600 $\Omega$ Lines	—	+4 dB (1.23 V)	+18 dB (6.16 V)	XLR-3-32 type (Balanced) <sup>2</sup>
STUDIO MONITOR OUT [L, R]	150 $\Omega$	10k $\Omega$ Lines	—	+4 dB (1.23 V)	+18 dB (6.16 V)	Phone Jack (TRS) (Balanced) <sup>3</sup>
C-R MONITOR OUT LARGE [L, R]	75 $\Omega$	600 $\Omega$ Lines	—	+4 dB (1.23 V)	+18 dB (6.16 V)	XLR-3-32 type (Balanced) <sup>2</sup>
C-R MONITOR OUT SMALL [L, R]	75 $\Omega$	600 $\Omega$ Lines	—	+4 dB (1.23 V)	+18 dB (6.16 V)	XLR-3-32 type (Balanced) <sup>2</sup>
OMNI OUT 1–8	150 $\Omega$	10k $\Omega$ Lines	+18 dB (default)	+4 dB (1.23 V)	+18 dB (6.16 V)	Phone Jack (TRS) (Balanced) <sup>3</sup>
			+4 dB	–10 dB (0.245 V)	+4 dB (1.23 V)	
INSERT OUT 1–24	150 $\Omega$	10k $\Omega$ Lines	—	+4 dB (1.23 V)	+18 dB (6.16 V)	Phone Jack (TRS) (Balanced) <sup>3</sup>
PHONES	100 $\Omega$	8 $\Omega$ Phones	—	4 mW	25 mW	Stereo Phone Jack (TRS) (Unbalanced) <sup>4</sup>
		40 $\Omega$ Phones	—	12 mW	75 mW	

1. The maximum output level of each OMNI OUT can be set internally.
2. XLR-3-32 type connectors are balanced (1=GND, 2=HOT, 3=COLD).
3. Phone jacks are balanced (Tip=HOT, Ring=COLD, Sleeve=GND).
4. PHONES stereo phone jack is unbalanced (Tip=LEFT, Ring=RIGHT, Sleeve=GND).

STEREO OUT [L, R], 0 dBV is referenced to 1.00 Vrms.

In these specifications, when dB represents a specific voltage, 0 dB is referenced to 0.775 Vrms.

All output DA converters (except INSERT OUT 1–24) are 24-bit, 128-times oversampling.

## Digital Input Spec

Input		Format	Data length	Level	Connector
2TR IN DIGITAL	1	AES/EBU	24-bit	RS422	XLR-3-31 type (Balanced) <sup>1</sup>
	2	AES/EBU	24-bit	RS422	XLR-3-31 type (Balanced) <sup>1</sup>
	3	IEC-60958	24-bit	0.5 Vpp/75 Ω	RCA pin jack
CASCADE IN		—	—	RS422	D-SUB Half Pitch Connector 68P (Female)

1. XLR-3-31 type connectors are balanced (1=GND, 2=HOT, 3=COLD).

## Digital Output Spec

Output		Format	Data length	Level	Connector
2TR OUT DIGITAL	1	AES/EBU <sup>1</sup> Professional use	24-bit <sup>2</sup>	RS422	XLR-3-32 type (Balanced) <sup>3</sup>
	2	AES/EBU <sup>1</sup> Professional use	24-bit <sup>2</sup>	RS422	XLR-3-32 type (Balanced) <sup>3</sup>
	3	IEC-60958 <sup>4</sup> Consumer use	24-bit <sup>2</sup>	0.5V pp/75 Ω	RCA pin jack
CASCADE OUT		—	—	RS422	D-SUB Half Pitch Connector 68P (Female)

1. Channel status of 2TR OUT DIGITAL 1, 2

Type: 2 audio channels

Emphasis: NO

Sampling rate: depends on the internal configuration

2. Dither: word length 16/20/24 bit

3. XLR-3-32 type connectors are balanced (1=GND, 2=HOT, 3=COLD).

4. Channel status of 2TR OUT DIGITAL 3

Type: 2 audio channels

Category code: 2 channel PCM encoder/decoder

Copy prohibit: NO

Emphasis: NO

Clock accuracy: Level II (1000 ppm)

Sampling rate: depends on the internal configuration

## I/O Slot Spec

Each I/O SLOT accepts a digital interface card. Only SLOT #1 has a serial interface.

Card Name	Function	Input	Output	Number of available cards
MY16-AT	ADAT	16 IN	16OUT (depends on output patch) <sup>1</sup>	6
MY8-AT	ADAT	8 IN	8 OUT (depends on output patch) <sup>1</sup>	6
MY16-TD	TASCAM	16 IN	16 OUT (depends on output patch) <sup>1</sup>	6
MY8-TD	TASCAM	8 IN	8 OUT (depends on output patch) <sup>1</sup>	6
MY16-AE	AES/EBU	16 IN	16 OUT (depends on output patch) <sup>1</sup>	6
MY8-AE	AES/EBU	8 IN	8 OUT (depends on output patch) <sup>1</sup>	6
MY8-AEB	AES/EBU	8 IN	8 OUT (depends on output patch) <sup>1</sup>	6
MY16-C	CobraNet	16 IN	16 OUT (depends on output patch) <sup>1</sup>	1
MY4-AD	ANALOG IN	4 IN	—	6
MY8-AD	ANALOG IN	8 IN	—	6
MY4-DA	ANALOG OUT	—	4 OUT (depends on output patch) <sup>1</sup>	6
MY8-AD24	ANALOG IN	8 IN	—	6
MY8-AD96	ANALOG IN	8 IN	—	6
MY8-DA96	ANALOG OUT	—	8 OUT (depends on output patch) <sup>1</sup>	6
MY8-AE96S	AES/EBU	8 IN	8 OUT (depends on output patch) <sup>1</sup>	4
MY8-AE96	AES/EBU	8 IN	8 OUT (depends on output patch) <sup>1</sup>	6
MY8-mLAN	mLAN	8 IN	8 OUT (depends on output patch) <sup>1</sup>	6
MY16-mLAN	mLAN	16 IN	16 OUT (depends on output patch) <sup>1</sup>	3
Waves Y56K	Effect & I/O	8 IN	8 OUT (depends on output patch) <sup>1</sup>	3
Waves Y96K	Effect & I/O	8 IN	8 OUT (depends on output patch) <sup>1</sup>	3
Apogee AP8AD	ANALOG IN	8 IN	—	2
Apogee AP8DA	ANALOG OUT	—	8 OUT (depends on output patch) <sup>1</sup>	2

1. See the Digital I/O chapter. Details depend on each interface card.

## Control I/O Spec

I/O Port	Format	Level	Connector in Console	
TO HOST	Serial	—	Mini DIN Connector 8P	
	USB	USB 1.1	0 V~3.3 V	B type USB connector
MIDI	IN	MIDI	—	DIN Connector 5P
	OUT	MIDI	—	DIN Connector 5P
	THRU	MIDI	—	DIN Connector 5P
TIME CODE IN	MTC	MIDI	—	DIN Connector 5P
	SMPTE	SMPTE	Nominal -10 dB/10k Ω	XLR-3-31 type (Balanced) <sup>1</sup>
WORD CLOCK	IN	—	TTL/75 Ω (ON/OFF) <sup>2</sup>	BNC Connector
	OUT 1, 2	—	TTL/75 Ω	BNC Connector
CONTROL	—	—	—	D-SUB Connector 25P (Female)
REMOTE	—	—	RS422	D-SUB Connector 9P (Male)
KEYBOARD	PS/2	—	—	DIN Connector 6P
STORAGE CARD	—	—	—	SmartMedia slot
METER	—	—	RS422	D-SUB Connector 15P (Female)

1. XLR-3-31 type connectors are balanced (1=GND, 2=HOT, 3=COLD).
2. This switch is on the rear panel.

## Connector Pin Assignments

### CASCADE IN

Pin	Signal	Pin	Signal
1	GND	35	GND
2	INPUT 1-2(+)	36	INPUT 1-2(-)
3	INPUT 3-4(+)	37	INPUT 3-4(-)
4	INPUT 5-6(+)	38	INPUT 5-6(-)
5	INPUT 7-8(+)	39	INPUT 7-8(-)
6	INPUT 9-10(+)	40	INPUT 9-10(-)
7	INPUT 11-12(+)	41	INPUT 11-12(-)
8	INPUT 13-14(+)	42	INPUT 13-14(-)
9	INPUT 15-16(+)	43	INPUT 15-16(-)
10	DTR IN(+)	44	DTR IN(-)
11	RTS OUT(+)	45	RTS OUT(-)
12	GND	46	GND
13	WORD CLOCK IN(+)	47	WORD CLOCK IN(-)
14	WORD CLOCK OUT(+)	48	WORD CLOCK OUT(-)
15	CONTROL IN(+)	49	CONTROL IN(-)
16	CONTROL OUT(+)	50	CONTROL OUT(-)
17	GND	51	ID6 IN
18	GND	52	ID6 OUT
19	INPUT 17-18(+)	53	INPUT 17-18(-)
20	INPUT 19-20(+)	54	INPUT 19-20(-)
21	INPUT 21-22(+)	55	INPUT 21-22(-)
22	INPUT 23-24(+)	56	INPUT 23-24(-)
23	RESERVED	57	RESERVED
24	RESERVED	58	RESERVED
25	RESERVED	59	RESERVED
26	RESERVED	60	RESERVED
27	ID0 IN	61	ID1 IN
28	ID2 IN	62	ID3 IN
29	ID4 IN	63	ID5 IN
30	ID0 OUT	64	ID1 OUT
31	ID2 OUT	65	ID3 OUT
32	ID4 OUT	66	ID5 OUT
33	MSB IN	67	2CH/LINE IN
34	FG	68	FG

### CASCADE OUT

Pin	Signal	Pin	Signal
1	GND	35	GND
2	OUTPUT 1-2(+)	36	OUTPUT 1-2(-)
3	OUTPUT 3-4(+)	37	OUTPUT 3-4(-)
4	OUTPUT 5-6(+)	38	OUTPUT 5-6(-)
5	OUTPUT 7-8(+)	39	OUTPUT 7-8(-)
6	OUTPUT 9-10(+)	40	OUTPUT 9-10(-)
7	OUTPUT 11-12(+)	41	OUTPUT 11-12(-)
8	OUTPUT 13-14(+)	42	OUTPUT 13-14(-)
9	OUTPUT 15-16(+)	43	OUTPUT 15-16(-)
10	DTR OUT(+)	44	DTR OUT(-)
11	RTS IN(+)	45	RTS IN(-)
12	GND	46	GND
13	WORD CLOCK OUT(+)	47	WORD CLOCK OUT(-)
14	WORD CLOCK IN(+)	48	WORD CLOCK IN(-)
15	CONTROL OUT(+)	49	CONTROL OUT(-)
16	CONTROL IN(+)	50	CONTROL IN(-)
17	GND	51	ID6 OUT
18	GND	52	ID6 IN
19	OUTPUT 17-18(+)	53	OUTPUT 17-18(-)
20	OUTPUT 19-20(+)	54	OUTPUT 19-20(-)
21	OUTPUT 21-22(+)	55	OUTPUT 21-22(-)
22	OUTPUT 23-24(+)	56	OUTPUT 23-24(-)
23	RESERVED	57	RESERVED
24	RESERVED	58	RESERVED
25	RESERVED	59	RESERVED
26	RESERVED	60	RESERVED
27	ID0 OUT	61	ID1 OUT
28	ID2 OUT	62	ID3 OUT
29	ID4 OUT	63	ID5 OUT
30	ID0 IN	64	ID1 IN
31	ID2 IN	65	ID3 IN
32	ID4 IN	66	ID5 IN
33	MSB OUT	67	2CH/LINE OUT
34	FG	68	FG

### REMOTE Port

Pin	Signal	Pin	Signal
1	GND	6	RX+/GND <sup>1</sup>
2	RX-/RX- <sup>1</sup>	7	RTS/RX+ <sup>1</sup>
3	TX-/TX+ <sup>1</sup>	8	CTS/TX- <sup>1</sup>
4	TX+/GND <sup>1</sup>	9	GND
5	N.C.		

1. RS422 (for AD8HR/AD824)/SONY 9-pin protocol (P2).

### CONTROL Port

Pin	Signal	Pin	Signal	Pin	Signal
1	GPO0	10	GPI1	19	GND
2	GPO2	11	N.C.	20	GND
3	GPO4	12	SMODE <sup>1</sup>	21	+5V
4	GPO6	13	SPARE <sup>1</sup>	22	GPI0
5	GND	14	GPO1	23	N.C.
6	GND	15	GPO3	24	SOLO <sup>1</sup>
7	GND	16	GPO5	25	MAS/SLV <sup>1</sup>
8	GND	17	GPO7		
9	+5V	18	GND		

1. For 02R SOLO control.

# Dimensions

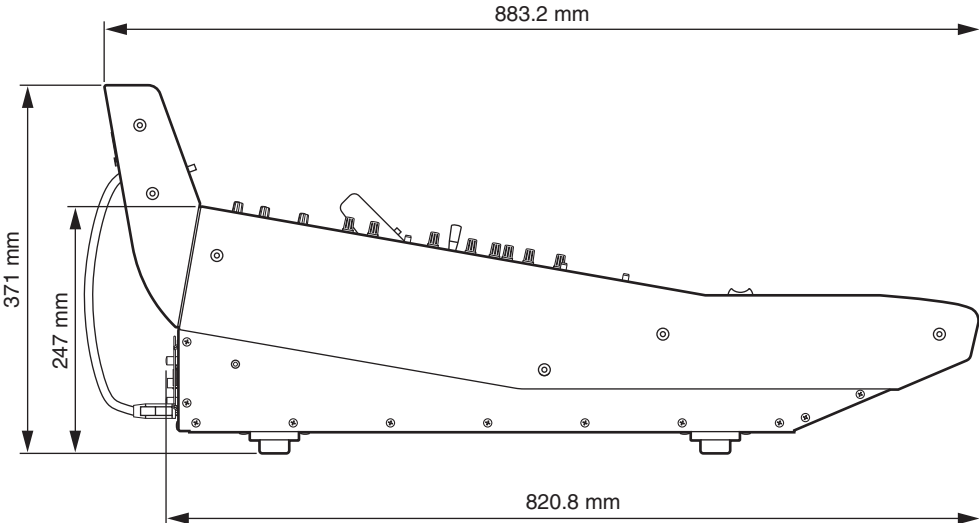
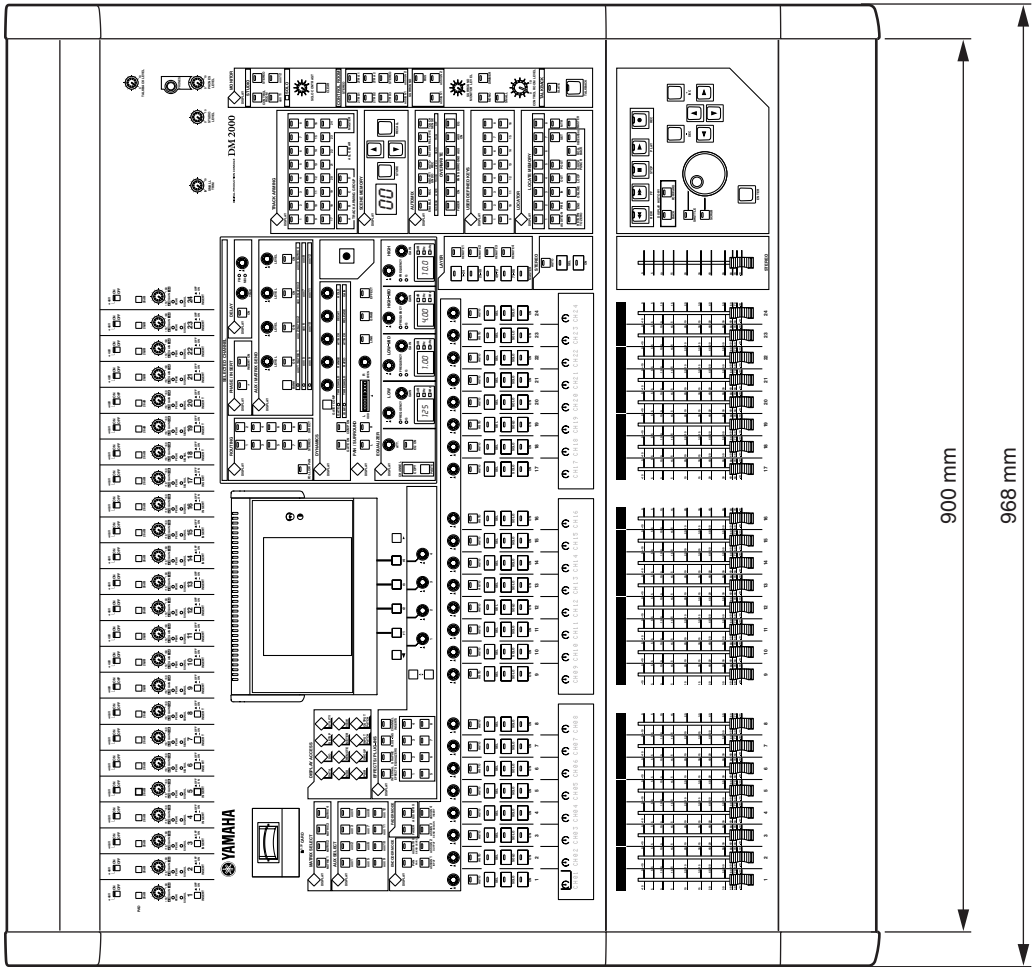

Specifications and external appearance subject to change without notice.

For European Model  
Purchaser/User Information specified in EN55103-1 and EN55103-2.  
Inrush Current: 31 A  
Conformed Environment: E1, E2, E3 and E4

# Appendix C: MIDI

## Scene Memory to Program Change Table

Program Change #	Initial Scene #	User Scene #
1	01	
2	02	
3	03	
4	04	
5	05	
6	06	
7	07	
8	08	
9	09	
10	10	
11	11	
12	12	
13	13	
14	14	
15	15	
16	16	
17	17	
18	18	
19	19	
20	20	
21	21	
22	22	
23	23	
24	24	
25	25	
26	26	
27	27	
28	28	
29	29	
30	30	
31	31	
32	32	
33	33	
34	34	
35	35	
36	36	
37	37	
38	38	
39	39	
40	40	
41	41	
42	42	
43	43	

Program Change #	Initial Scene #	User Scene #
44	44	
45	45	
46	46	
47	47	
48	48	
49	49	
50	50	
51	51	
52	52	
53	53	
54	54	
55	55	
56	56	
57	57	
58	58	
59	59	
60	60	
61	61	
62	62	
63	63	
64	64	
65	65	
66	66	
67	67	
68	68	
69	69	
70	70	
71	71	
72	72	
73	73	
74	74	
75	75	
76	76	
77	77	
78	78	
79	79	
80	80	
81	81	
82	82	
83	83	
84	84	
85	85	
86	86	

Program Change#	Initial Scene #	User Scene #
87	87	
88	88	
89	89	
90	90	
91	91	
92	92	
93	93	
94	94	
95	95	
96	96	
97	97	
98	98	
99	99	
100	00	
101	—	
102	—	
103	—	
104	—	
105	—	
106	—	
107	—	
108	—	
109	—	
110	—	
111	—	
112	—	
113	—	
114	—	
115	—	
116	—	
117	—	
118	—	
119	—	
120	—	
121	—	
122	—	
123	—	
124	—	
125	—	
126	—	
127	—	
128	—	



## Initial Parameter to Control Change Table

## CHANNEL1

#	HIGH	MID	LOW
0	NO ASSIGN		
1	FADER H	CHANNEL	INPUT1
2	FADER H	CHANNEL	INPUT2
3	FADER H	CHANNEL	INPUT3
4	FADER H	CHANNEL	INPUT4
5	FADER H	CHANNEL	INPUT5
6	FADER H	CHANNEL	INPUT6
7	FADER H	CHANNEL	INPUT7
8	FADER H	CHANNEL	INPUT8
9	FADER H	CHANNEL	INPUT9
10	FADER H	CHANNEL	INPUT10
11	FADER H	CHANNEL	INPUT11
12	FADER H	CHANNEL	INPUT12
13	FADER H	CHANNEL	INPUT13
14	FADER H	CHANNEL	INPUT14
15	FADER H	CHANNEL	INPUT15
16	FADER H	CHANNEL	INPUT16
17	FADER H	CHANNEL	INPUT17
18	FADER H	CHANNEL	INPUT18
19	FADER H	CHANNEL	INPUT19
20	FADER H	CHANNEL	INPUT20
21	FADER H	CHANNEL	INPUT21
22	FADER H	CHANNEL	INPUT22
23	FADER H	CHANNEL	INPUT23
24	FADER H	CHANNEL	INPUT24
25	FADER H	MASTER	BUS1
26	FADER H	MASTER	BUS2
27	FADER H	MASTER	BUS3
28	FADER H	MASTER	BUS4
29	FADER H	MASTER	BUS5
30	FADER H	MASTER	BUS6
31	FADER H	MASTER	BUS7
32	NO ASSIGN		
33	FADER L	CHANNEL	INPUT1
34	FADER L	CHANNEL	INPUT2
35	FADER L	CHANNEL	INPUT3
36	FADER L	CHANNEL	INPUT4
37	FADER L	CHANNEL	INPUT5
38	FADER L	CHANNEL	INPUT6
39	FADER L	CHANNEL	INPUT7
40	FADER L	CHANNEL	INPUT8
41	FADER L	CHANNEL	INPUT9
42	FADER L	CHANNEL	INPUT10
43	FADER L	CHANNEL	INPUT11
44	FADER L	CHANNEL	INPUT12
45	FADER L	CHANNEL	INPUT13
46	FADER L	CHANNEL	INPUT14
47	FADER L	CHANNEL	INPUT15
48	FADER L	CHANNEL	INPUT16
49	FADER L	CHANNEL	INPUT17
50	FADER L	CHANNEL	INPUT18
51	FADER L	CHANNEL	INPUT19
52	FADER L	CHANNEL	INPUT20
53	FADER L	CHANNEL	INPUT21
54	FADER L	CHANNEL	INPUT22
55	FADER L	CHANNEL	INPUT23
56	FADER L	CHANNEL	INPUT24

#	HIGH	MID	LOW
57	FADER L	MASTER	BUS1
58	FADER L	MASTER	BUS2
59	FADER L	MASTER	BUS3
60	FADER L	MASTER	BUS4
61	FADER L	MASTER	BUS5
62	FADER L	MASTER	BUS6
63	FADER L	MASTER	BUS7
64	ON	CHANNEL	INPUT1
65	ON	CHANNEL	INPUT2
66	ON	CHANNEL	INPUT3
67	ON	CHANNEL	INPUT4
68	ON	CHANNEL	INPUT5
69	ON	CHANNEL	INPUT6
70	ON	CHANNEL	INPUT7
71	ON	CHANNEL	INPUT8
72	ON	CHANNEL	INPUT9
73	ON	CHANNEL	INPUT10
74	ON	CHANNEL	INPUT11
75	ON	CHANNEL	INPUT12
76	ON	CHANNEL	INPUT13
77	ON	CHANNEL	INPUT14
78	ON	CHANNEL	INPUT15
79	ON	CHANNEL	INPUT16
80	ON	CHANNEL	INPUT17
81	ON	CHANNEL	INPUT18
82	ON	CHANNEL	INPUT19
83	ON	CHANNEL	INPUT20
84	ON	CHANNEL	INPUT21
85	ON	CHANNEL	INPUT22
86	ON	CHANNEL	INPUT23
87	ON	CHANNEL	INPUT24
88	NO ASSIGN		
89	PAN	CHANNEL	INPUT1
90	PAN	CHANNEL	INPUT2
91	PAN	CHANNEL	INPUT3
92	PAN	CHANNEL	INPUT4
93	PAN	CHANNEL	INPUT5
94	PAN	CHANNEL	INPUT6
95	PAN	CHANNEL	INPUT7
102	PAN	CHANNEL	INPUT8
103	PAN	CHANNEL	INPUT9
104	PAN	CHANNEL	INPUT10
105	PAN	CHANNEL	INPUT11
106	PAN	CHANNEL	INPUT12
107	PAN	CHANNEL	INPUT13
108	PAN	CHANNEL	INPUT14
109	PAN	CHANNEL	INPUT15
110	PAN	CHANNEL	INPUT16
111	PAN	CHANNEL	INPUT17
112	PAN	CHANNEL	INPUT18
113	PAN	CHANNEL	INPUT19
114	PAN	CHANNEL	INPUT20
115	PAN	CHANNEL	INPUT21
116	PAN	CHANNEL	INPUT22
117	PAN	CHANNEL	INPUT23
118	PAN	CHANNEL	INPUT24
119	NO ASSIGN		

**CHANNEL2**

#	HIGH	MID	LOW
0	NO ASSIGN		
1	FADER H	CHANNEL	INPUT25
2	FADER H	CHANNEL	INPUT26
3	FADER H	CHANNEL	INPUT27
4	FADER H	CHANNEL	INPUT28
5	FADER H	CHANNEL	INPUT29
6	FADER H	CHANNEL	INPUT30
7	FADER H	CHANNEL	INPUT31
8	FADER H	CHANNEL	INPUT32
9	FADER H	CHANNEL	INPUT33
10	FADER H	CHANNEL	INPUT34
11	FADER H	CHANNEL	INPUT35
12	FADER H	CHANNEL	INPUT36
13	FADER H	CHANNEL	INPUT37
14	FADER H	CHANNEL	INPUT38
15	FADER H	CHANNEL	INPUT39
16	FADER H	CHANNEL	INPUT40
17	FADER H	CHANNEL	INPUT41
18	FADER H	CHANNEL	INPUT42
19	FADER H	CHANNEL	INPUT43
20	FADER H	CHANNEL	INPUT44
21	FADER H	CHANNEL	INPUT45
22	FADER H	CHANNEL	INPUT46
23	FADER H	CHANNEL	INPUT47
24	FADER H	CHANNEL	INPUT48
25	FADER H	MASTER	BUS8
26	FADER H	MASTER	AUX1
27	FADER H	MASTER	AUX2
28	FADER H	MASTER	AUX3
29	FADER H	MASTER	AUX4
30	FADER H	MASTER	AUX5
31	FADER H	MASTER	AUX6
32	NO ASSIGN		
33	FADER L	CHANNEL	INPUT25
34	FADER L	CHANNEL	INPUT26
35	FADER L	CHANNEL	INPUT27
36	FADER L	CHANNEL	INPUT28
37	FADER L	CHANNEL	INPUT29
38	FADER L	CHANNEL	INPUT30
39	FADER L	CHANNEL	INPUT31
40	FADER L	CHANNEL	INPUT32
41	FADER L	CHANNEL	INPUT33
42	FADER L	CHANNEL	INPUT34
43	FADER L	CHANNEL	INPUT35
44	FADER L	CHANNEL	INPUT36
45	FADER L	CHANNEL	INPUT37
46	FADER L	CHANNEL	INPUT38
47	FADER L	CHANNEL	INPUT39
48	FADER L	CHANNEL	INPUT40
49	FADER L	CHANNEL	INPUT41
50	FADER L	CHANNEL	INPUT42
51	FADER L	CHANNEL	INPUT43
52	FADER L	CHANNEL	INPUT44
53	FADER L	CHANNEL	INPUT45
54	FADER L	CHANNEL	INPUT46
55	FADER L	CHANNEL	INPUT47
56	FADER L	CHANNEL	INPUT48

#	HIGH	MID	LOW
57	FADER L	MASTER	BUS8
58	FADER L	MASTER	AUX1
59	FADER L	MASTER	AUX2
60	FADER L	MASTER	AUX3
61	FADER L	MASTER	AUX4
62	FADER L	MASTER	AUX5
63	FADER L	MASTER	AUX6
64	ON	CHANNEL	INPUT25
65	ON	CHANNEL	INPUT26
66	ON	CHANNEL	INPUT27
67	ON	CHANNEL	INPUT28
68	ON	CHANNEL	INPUT29
69	ON	CHANNEL	INPUT30
70	ON	CHANNEL	INPUT31
71	ON	CHANNEL	INPUT32
72	ON	CHANNEL	INPUT33
73	ON	CHANNEL	INPUT34
74	ON	CHANNEL	INPUT35
75	ON	CHANNEL	INPUT36
76	ON	CHANNEL	INPUT37
77	ON	CHANNEL	INPUT38
78	ON	CHANNEL	INPUT39
79	ON	CHANNEL	INPUT40
80	ON	CHANNEL	INPUT41
81	ON	CHANNEL	INPUT42
82	ON	CHANNEL	INPUT43
83	ON	CHANNEL	INPUT44
84	ON	CHANNEL	INPUT45
85	ON	CHANNEL	INPUT46
86	ON	CHANNEL	INPUT47
87	ON	CHANNEL	INPUT48
88	NO ASSIGN		
89	PAN	CHANNEL	INPUT25
90	PAN	CHANNEL	INPUT26
91	PAN	CHANNEL	INPUT27
92	PAN	CHANNEL	INPUT28
93	PAN	CHANNEL	INPUT29
94	PAN	CHANNEL	INPUT30
95	PAN	CHANNEL	INPUT31
102	PAN	CHANNEL	INPUT32
103	PAN	CHANNEL	INPUT33
104	PAN	CHANNEL	INPUT34
105	PAN	CHANNEL	INPUT35
106	PAN	CHANNEL	INPUT36
107	PAN	CHANNEL	INPUT37
108	PAN	CHANNEL	INPUT38
109	PAN	CHANNEL	INPUT39
110	PAN	CHANNEL	INPUT40
111	PAN	CHANNEL	INPUT41
112	PAN	CHANNEL	INPUT42
113	PAN	CHANNEL	INPUT43
114	PAN	CHANNEL	INPUT44
115	PAN	CHANNEL	INPUT45
116	PAN	CHANNEL	INPUT46
117	PAN	CHANNEL	INPUT47
118	PAN	CHANNEL	INPUT48
119	NO ASSIGN		

## CHANNEL3

#	HIGH	MID	LOW
0	NO ASSIGN		
1	FADER H	CHANNEL	INPUT49
2	FADER H	CHANNEL	INPUT50
3	FADER H	CHANNEL	INPUT51
4	FADER H	CHANNEL	INPUT52
5	FADER H	CHANNEL	INPUT53
6	FADER H	CHANNEL	INPUT54
7	FADER H	CHANNEL	INPUT55
8	FADER H	CHANNEL	INPUT56
9	FADER H	CHANNEL	INPUT57
10	FADER H	CHANNEL	INPUT58
11	FADER H	CHANNEL	INPUT59
12	FADER H	CHANNEL	INPUT60
13	FADER H	CHANNEL	INPUT61
14	FADER H	CHANNEL	INPUT62
15	FADER H	CHANNEL	INPUT63
16	FADER H	CHANNEL	INPUT64
17	FADER H	CHANNEL	INPUT65
18	FADER H	CHANNEL	INPUT66
19	FADER H	CHANNEL	INPUT67
20	FADER H	CHANNEL	INPUT68
21	FADER H	CHANNEL	INPUT69
22	FADER H	CHANNEL	INPUT70
23	FADER H	CHANNEL	INPUT71
24	FADER H	CHANNEL	INPUT72
25	FADER H	MASTER	AUX7
26	FADER H	MASTER	AUX8
27	FADER H	MASTER	AUX9
28	FADER H	MASTER	AUX10
29	FADER H	MASTER	AUX11
30	FADER H	MASTER	AUX12
31	NO ASSIGN		
32	NO ASSIGN		
33	FADER L	CHANNEL	INPUT49
34	FADER L	CHANNEL	INPUT50
35	FADER L	CHANNEL	INPUT51
36	FADER L	CHANNEL	INPUT52
37	FADER L	CHANNEL	INPUT53
38	FADER L	CHANNEL	INPUT54
39	FADER L	CHANNEL	INPUT55
40	FADER L	CHANNEL	INPUT56
41	FADER L	CHANNEL	INPUT57
42	FADER L	CHANNEL	INPUT58
43	FADER L	CHANNEL	INPUT59
44	FADER L	CHANNEL	INPUT60
45	FADER L	CHANNEL	INPUT61
46	FADER L	CHANNEL	INPUT62
47	FADER L	CHANNEL	INPUT63
48	FADER L	CHANNEL	INPUT64
49	FADER L	CHANNEL	INPUT65
50	FADER L	CHANNEL	INPUT66
51	FADER L	CHANNEL	INPUT67
52	FADER L	CHANNEL	INPUT68
53	FADER L	CHANNEL	INPUT69
54	FADER L	CHANNEL	INPUT70
55	FADER L	CHANNEL	INPUT71
56	FADER L	CHANNEL	INPUT72

#	HIGH	MID	LOW
57	FADER L	MASTER	AUX7
58	FADER L	MASTER	AUX8
59	FADER L	MASTER	AUX9
60	FADER L	MASTER	AUX10
61	FADER L	MASTER	AUX11
62	FADER L	MASTER	AUX12
63	NO ASSIGN		
64	ON	CHANNEL	INPUT49
65	ON	CHANNEL	INPUT50
66	ON	CHANNEL	INPUT51
67	ON	CHANNEL	INPUT52
68	ON	CHANNEL	INPUT53
69	ON	CHANNEL	INPUT54
70	ON	CHANNEL	INPUT55
71	ON	CHANNEL	INPUT56
72	ON	CHANNEL	INPUT57
73	ON	CHANNEL	INPUT58
74	ON	CHANNEL	INPUT59
75	ON	CHANNEL	INPUT60
76	ON	CHANNEL	INPUT61
77	ON	CHANNEL	INPUT62
78	ON	CHANNEL	INPUT63
79	ON	CHANNEL	INPUT64
80	ON	CHANNEL	INPUT65
81	ON	CHANNEL	INPUT66
82	ON	CHANNEL	INPUT67
83	ON	CHANNEL	INPUT68
84	ON	CHANNEL	INPUT69
85	ON	CHANNEL	INPUT70
86	ON	CHANNEL	INPUT71
87	ON	CHANNEL	INPUT72
88	NO ASSIGN		
89	PAN	CHANNEL	INPUT49
90	PAN	CHANNEL	INPUT50
91	PAN	CHANNEL	INPUT51
92	PAN	CHANNEL	INPUT52
93	PAN	CHANNEL	INPUT53
94	PAN	CHANNEL	INPUT54
95	PAN	CHANNEL	INPUT55
102	PAN	CHANNEL	INPUT56
103	PAN	CHANNEL	INPUT57
104	PAN	CHANNEL	INPUT58
105	PAN	CHANNEL	INPUT59
106	PAN	CHANNEL	INPUT60
107	PAN	CHANNEL	INPUT61
108	PAN	CHANNEL	INPUT62
109	PAN	CHANNEL	INPUT63
110	PAN	CHANNEL	INPUT64
111	PAN	CHANNEL	INPUT65
112	PAN	CHANNEL	INPUT66
113	PAN	CHANNEL	INPUT67
114	PAN	CHANNEL	INPUT68
115	PAN	CHANNEL	INPUT69
116	PAN	CHANNEL	INPUT70
117	PAN	CHANNEL	INPUT71
118	PAN	CHANNEL	INPUT72
119	NO ASSIGN		

## CHANNEL4

#	HIGH	MID	LOW
0	NO ASSIGN		
1	FADER H	CHANNEL	INPUT73
2	FADER H	CHANNEL	INPUT74
3	FADER H	CHANNEL	INPUT75
4	FADER H	CHANNEL	INPUT76
5	FADER H	CHANNEL	INPUT77
6	FADER H	CHANNEL	INPUT78
7	FADER H	CHANNEL	INPUT79
8	FADER H	CHANNEL	INPUT80
9	FADER H	CHANNEL	INPUT81
10	FADER H	CHANNEL	INPUT82
11	FADER H	CHANNEL	INPUT83
12	FADER H	CHANNEL	INPUT84
13	FADER H	CHANNEL	INPUT85
14	FADER H	CHANNEL	INPUT86
15	FADER H	CHANNEL	INPUT87
16	FADER H	CHANNEL	INPUT88
17	FADER H	CHANNEL	INPUT89
18	FADER H	CHANNEL	INPUT90
19	FADER H	CHANNEL	INPUT91
20	FADER H	CHANNEL	INPUT92
21	FADER H	CHANNEL	INPUT93
22	FADER H	CHANNEL	INPUT94
23	FADER H	CHANNEL	INPUT95
24	FADER H	CHANNEL	INPUT96
25	FADER H	MASTER	MATRIX1
26	FADER H	MASTER	MATRIX2
27	FADER H	MASTER	MATRIX3
28	FADER H	MASTER	MATRIX4
29	FADER H	MASTER	STEREO
30	NO ASSIGN		
31	NO ASSIGN		
32	NO ASSIGN		
33	FADER L	CHANNEL	INPUT73
34	FADER L	CHANNEL	INPUT74
35	FADER L	CHANNEL	INPUT75
36	FADER L	CHANNEL	INPUT76
37	FADER L	CHANNEL	INPUT77
38	FADER L	CHANNEL	INPUT78
39	FADER L	CHANNEL	INPUT79
40	FADER L	CHANNEL	INPUT80
41	FADER L	CHANNEL	INPUT81
42	FADER L	CHANNEL	INPUT82
43	FADER L	CHANNEL	INPUT83
44	FADER L	CHANNEL	INPUT84
45	FADER L	CHANNEL	INPUT85
46	FADER L	CHANNEL	INPUT86
47	FADER L	CHANNEL	INPUT87
48	FADER L	CHANNEL	INPUT88
49	FADER L	CHANNEL	INPUT89
50	FADER L	CHANNEL	INPUT90
51	FADER L	CHANNEL	INPUT91
52	FADER L	CHANNEL	INPUT92
53	FADER L	CHANNEL	INPUT93
54	FADER L	CHANNEL	INPUT94
55	FADER L	CHANNEL	INPUT95
56	FADER L	CHANNEL	INPUT96

#	HIGH	MID	LOW
57	FADER L	MASTER	MATRIX1
58	FADER L	MASTER	MATRIX2
59	FADER L	MASTER	MATRIX3
60	FADER L	MASTER	MATRIX4
61	FADER L	MASTER	STEREO
62	NO ASSIGN		
63	NO ASSIGN		
64	ON	CHANNEL	INPUT73
65	ON	CHANNEL	INPUT74
66	ON	CHANNEL	INPUT75
67	ON	CHANNEL	INPUT76
68	ON	CHANNEL	INPUT77
69	ON	CHANNEL	INPUT78
70	ON	CHANNEL	INPUT79
71	ON	CHANNEL	INPUT80
72	ON	CHANNEL	INPUT81
73	ON	CHANNEL	INPUT82
74	ON	CHANNEL	INPUT83
75	ON	CHANNEL	INPUT84
76	ON	CHANNEL	INPUT85
77	ON	CHANNEL	INPUT86
78	ON	CHANNEL	INPUT87
79	ON	CHANNEL	INPUT88
80	ON	CHANNEL	INPUT89
81	ON	CHANNEL	INPUT90
82	ON	CHANNEL	INPUT91
83	ON	CHANNEL	INPUT92
84	ON	CHANNEL	INPUT93
85	ON	CHANNEL	INPUT94
86	ON	CHANNEL	INPUT95
87	ON	CHANNEL	INPUT96
88	NO ASSIGN		
89	PAN	CHANNEL	INPUT73
90	PAN	CHANNEL	INPUT74
91	PAN	CHANNEL	INPUT75
92	PAN	CHANNEL	INPUT76
93	PAN	CHANNEL	INPUT77
94	PAN	CHANNEL	INPUT78
95	PAN	CHANNEL	INPUT79
102	PAN	CHANNEL	INPUT80
103	PAN	CHANNEL	INPUT81
104	PAN	CHANNEL	INPUT82
105	PAN	CHANNEL	INPUT83
106	PAN	CHANNEL	INPUT84
107	PAN	CHANNEL	INPUT85
108	PAN	CHANNEL	INPUT86
109	PAN	CHANNEL	INPUT87
110	PAN	CHANNEL	INPUT88
111	PAN	CHANNEL	INPUT89
112	PAN	CHANNEL	INPUT90
113	PAN	CHANNEL	INPUT91
114	PAN	CHANNEL	INPUT92
115	PAN	CHANNEL	INPUT93
116	PAN	CHANNEL	INPUT94
117	PAN	CHANNEL	INPUT95
118	PAN	CHANNEL	INPUT96
119	NO ASSIGN		

## CHANNEL5

#	HIGH	MID	LOW
0	NO ASSIGN		
1	EQ	ATT H	INPUT1
2	EQ	ATT H	INPUT2
3	EQ	ATT H	INPUT3
4	EQ	ATT H	INPUT4
5	EQ	ATT H	INPUT5
6	EQ	ATT H	INPUT6
7	EQ	ATT H	INPUT7
8	EQ	ATT H	INPUT8
9	EQ	ATT H	INPUT9
10	EQ	ATT H	INPUT10
11	EQ	ATT H	INPUT11
12	EQ	ATT H	INPUT12
13	EQ	ATT H	INPUT13
14	EQ	ATT H	INPUT14
15	EQ	ATT H	INPUT15
16	EQ	ATT H	INPUT16
17	EQ	ATT H	INPUT17
18	EQ	ATT H	INPUT18
19	EQ	ATT H	INPUT19
20	EQ	ATT H	INPUT20
21	EQ	ATT H	INPUT21
22	EQ	ATT H	INPUT22
23	EQ	ATT H	INPUT23
24	EQ	ATT H	INPUT24
25	EQ	ATT H	BUS1
26	EQ	ATT H	BUS2
27	EQ	ATT H	BUS3
28	EQ	ATT H	BUS4
29	EQ	ATT H	BUS5
30	EQ	ATT H	BUS6
31	EQ	ATT H	BUS7
32	NO ASSIGN		
33	EQ	ATT L	INPUT1
34	EQ	ATT L	INPUT2
35	EQ	ATT L	INPUT3
36	EQ	ATT L	INPUT4
37	EQ	ATT L	INPUT5
38	EQ	ATT L	INPUT6
39	EQ	ATT L	INPUT7
40	EQ	ATT L	INPUT8
41	EQ	ATT L	INPUT9
42	EQ	ATT L	INPUT10
43	EQ	ATT L	INPUT11
44	EQ	ATT L	INPUT12
45	EQ	ATT L	INPUT13
46	EQ	ATT L	INPUT14
47	EQ	ATT L	INPUT15
48	EQ	ATT L	INPUT16
49	EQ	ATT L	INPUT17
50	EQ	ATT L	INPUT18
51	EQ	ATT L	INPUT19
52	EQ	ATT L	INPUT20
53	EQ	ATT L	INPUT21
54	EQ	ATT L	INPUT22
55	EQ	ATT L	INPUT23
56	EQ	ATT L	INPUT24

#	HIGH	MID	LOW
57	EQ	ATT L	BUS1
58	EQ	ATT L	BUS2
59	EQ	ATT L	BUS3
60	EQ	ATT L	BUS4
61	EQ	ATT L	BUS5
62	EQ	ATT L	BUS6
63	EQ	ATT L	BUS7
64	EQ	ON	INPUT1
65	EQ	ON	INPUT2
66	EQ	ON	INPUT3
67	EQ	ON	INPUT4
68	EQ	ON	INPUT5
69	EQ	ON	INPUT6
70	EQ	ON	INPUT7
71	EQ	ON	INPUT8
72	EQ	ON	INPUT9
73	EQ	ON	INPUT10
74	EQ	ON	INPUT11
75	EQ	ON	INPUT12
76	EQ	ON	INPUT13
77	EQ	ON	INPUT14
78	EQ	ON	INPUT15
79	EQ	ON	INPUT16
80	EQ	ON	INPUT17
81	EQ	ON	INPUT18
82	EQ	ON	INPUT19
83	EQ	ON	INPUT20
84	EQ	ON	INPUT21
85	EQ	ON	INPUT22
86	EQ	ON	INPUT23
87	EQ	ON	INPUT24
88	NO ASSIGN		
89	ON	MASTER	BUS1
90	ON	MASTER	BUS2
91	ON	MASTER	BUS3
92	ON	MASTER	BUS4
93	ON	MASTER	BUS5
94	ON	MASTER	BUS6
95	ON	MASTER	BUS7
102	ON	MASTER	BUS8
103	ON	MASTER	AUX1
104	ON	MASTER	AUX2
105	ON	MASTER	AUX3
106	ON	MASTER	AUX4
107	ON	MASTER	AUX5
108	ON	MASTER	AUX6
109	ON	MASTER	AUX7
110	ON	MASTER	AUX8
111	ON	MASTER	AUX9
112	ON	MASTER	AUX10
113	ON	MASTER	AUX11
114	ON	MASTER	AUX12
115	ON	MASTER	MATRIX1
116	ON	MASTER	MATRIX2
117	ON	MASTER	MATRIX3
118	ON	MASTER	MATRIX4
119	ON	MASTER	STEREO

**CHANNEL6**

#	HIGH	MID	LOW
0	NO ASSIGN		
1	EQ	ATT H	INPUT25
2	EQ	ATT H	INPUT26
3	EQ	ATT H	INPUT27
4	EQ	ATT H	INPUT28
5	EQ	ATT H	INPUT29
6	EQ	ATT H	INPUT30
7	EQ	ATT H	INPUT31
8	EQ	ATT H	INPUT32
9	EQ	ATT H	INPUT33
10	EQ	ATT H	INPUT34
11	EQ	ATT H	INPUT35
12	EQ	ATT H	INPUT36
13	EQ	ATT H	INPUT37
14	EQ	ATT H	INPUT38
15	EQ	ATT H	INPUT39
16	EQ	ATT H	INPUT40
17	EQ	ATT H	INPUT41
18	EQ	ATT H	INPUT42
19	EQ	ATT H	INPUT43
20	EQ	ATT H	INPUT44
21	EQ	ATT H	INPUT45
22	EQ	ATT H	INPUT46
23	EQ	ATT H	INPUT47
24	EQ	ATT H	INPUT48
25	EQ	ATT H	BUS8
26	EQ	ATT H	AUX1
27	EQ	ATT H	AUX2
28	EQ	ATT H	AUX3
29	EQ	ATT H	AUX4
30	EQ	ATT H	AUX5
31	EQ	ATT H	AUX6
32	NO ASSIGN		
33	EQ	ATT L	INPUT25
34	EQ	ATT L	INPUT26
35	EQ	ATT L	INPUT27
36	EQ	ATT L	INPUT28
37	EQ	ATT L	INPUT29
38	EQ	ATT L	INPUT30
39	EQ	ATT L	INPUT31
40	EQ	ATT L	INPUT32
41	EQ	ATT L	INPUT33
42	EQ	ATT L	INPUT34
43	EQ	ATT L	INPUT35
44	EQ	ATT L	INPUT36
45	EQ	ATT L	INPUT37
46	EQ	ATT L	INPUT38
47	EQ	ATT L	INPUT39
48	EQ	ATT L	INPUT40
49	EQ	ATT L	INPUT41
50	EQ	ATT L	INPUT42
51	EQ	ATT L	INPUT43
52	EQ	ATT L	INPUT44
53	EQ	ATT L	INPUT45
54	EQ	ATT L	INPUT46
55	EQ	ATT L	INPUT47
56	EQ	ATT L	INPUT48

#	HIGH	MID	LOW
57	EQ	ATT L	BUS8
58	EQ	ATT L	AUX1
59	EQ	ATT L	AUX2
60	EQ	ATT L	AUX3
61	EQ	ATT L	AUX4
62	EQ	ATT L	AUX5
63	EQ	ATT L	AUX6
64	EQ	ON	INPUT25
65	EQ	ON	INPUT26
66	EQ	ON	INPUT27
67	EQ	ON	INPUT28
68	EQ	ON	INPUT29
69	EQ	ON	INPUT30
70	EQ	ON	INPUT31
71	EQ	ON	INPUT32
72	EQ	ON	INPUT33
73	EQ	ON	INPUT34
74	EQ	ON	INPUT35
75	EQ	ON	INPUT36
76	EQ	ON	INPUT37
77	EQ	ON	INPUT38
78	EQ	ON	INPUT39
79	EQ	ON	INPUT40
80	EQ	ON	INPUT41
81	EQ	ON	INPUT42
82	EQ	ON	INPUT43
83	EQ	ON	INPUT44
84	EQ	ON	INPUT45
85	EQ	ON	INPUT46
86	EQ	ON	INPUT47
87	EQ	ON	INPUT48
88	NO ASSIGN		
89	NO ASSIGN		
90	NO ASSIGN		
91	NO ASSIGN		
92	NO ASSIGN		
93	NO ASSIGN		
94	NO ASSIGN		
95	NO ASSIGN		
102	NO ASSIGN		
103	NO ASSIGN		
104	NO ASSIGN		
105	NO ASSIGN		
106	NO ASSIGN		
107	NO ASSIGN		
108	NO ASSIGN		
109	NO ASSIGN		
110	NO ASSIGN		
111	NO ASSIGN		
112	NO ASSIGN		
113	NO ASSIGN		
114	NO ASSIGN		
115	NO ASSIGN		
116	NO ASSIGN		
117	NO ASSIGN		
118	NO ASSIGN		
119	NO ASSIGN		

## CHANNEL7

#	HIGH	MID	LOW
0	NO ASSIGN		
1	EQ	ATT H	INPUT49
2	EQ	ATT H	INPUT50
3	EQ	ATT H	INPUT51
4	EQ	ATT H	INPUT52
5	EQ	ATT H	INPUT53
6	EQ	ATT H	INPUT54
7	EQ	ATT H	INPUT55
8	EQ	ATT H	INPUT56
9	EQ	ATT H	INPUT57
10	EQ	ATT H	INPUT58
11	EQ	ATT H	INPUT59
12	EQ	ATT H	INPUT60
13	EQ	ATT H	INPUT61
14	EQ	ATT H	INPUT62
15	EQ	ATT H	INPUT63
16	EQ	ATT H	INPUT64
17	EQ	ATT H	INPUT65
18	EQ	ATT H	INPUT66
19	EQ	ATT H	INPUT67
20	EQ	ATT H	INPUT68
21	EQ	ATT H	INPUT69
22	EQ	ATT H	INPUT70
23	EQ	ATT H	INPUT71
24	EQ	ATT H	INPUT72
25	EQ	ATT H	AUX7
26	EQ	ATT H	AUX8
27	EQ	ATT H	AUX9
28	EQ	ATT H	AUX10
29	EQ	ATT H	AUX11
30	EQ	ATT H	AUX12
31	NO ASSIGN		
32	NO ASSIGN		
33	EQ	ATT L	INPUT49
34	EQ	ATT L	INPUT50
35	EQ	ATT L	INPUT51
36	EQ	ATT L	INPUT52
37	EQ	ATT L	INPUT53
38	EQ	ATT L	INPUT54
39	EQ	ATT L	INPUT55
40	EQ	ATT L	INPUT56
41	EQ	ATT L	INPUT57
42	EQ	ATT L	INPUT58
43	EQ	ATT L	INPUT59
44	EQ	ATT L	INPUT60
45	EQ	ATT L	INPUT61
46	EQ	ATT L	INPUT62
47	EQ	ATT L	INPUT63
48	EQ	ATT L	INPUT64
49	EQ	ATT L	INPUT65
50	EQ	ATT L	INPUT66
51	EQ	ATT L	INPUT67
52	EQ	ATT L	INPUT68
53	EQ	ATT L	INPUT69
54	EQ	ATT L	INPUT70
55	EQ	ATT L	INPUT71
56	EQ	ATT L	INPUT72

#	HIGH	MID	LOW
57	EQ	ATT L	AUX7
58	EQ	ATT L	AUX8
59	EQ	ATT L	AUX9
60	EQ	ATT L	AUX10
61	EQ	ATT L	AUX11
62	EQ	ATT L	AUX12
63	NO ASSIGN		
64	EQ	ON	INPUT49
65	EQ	ON	INPUT50
66	EQ	ON	INPUT51
67	EQ	ON	INPUT52
68	EQ	ON	INPUT53
69	EQ	ON	INPUT54
70	EQ	ON	INPUT55
71	EQ	ON	INPUT56
72	EQ	ON	INPUT57
73	EQ	ON	INPUT58
74	EQ	ON	INPUT59
75	EQ	ON	INPUT60
76	EQ	ON	INPUT61
77	EQ	ON	INPUT62
78	EQ	ON	INPUT63
79	EQ	ON	INPUT64
80	EQ	ON	INPUT65
81	EQ	ON	INPUT66
82	EQ	ON	INPUT67
83	EQ	ON	INPUT68
84	EQ	ON	INPUT69
85	EQ	ON	INPUT70
86	EQ	ON	INPUT71
87	EQ	ON	INPUT72
88	NO ASSIGN		
89	NO ASSIGN		
90	NO ASSIGN		
91	NO ASSIGN		
92	NO ASSIGN		
93	NO ASSIGN		
94	NO ASSIGN		
95	NO ASSIGN		
102	NO ASSIGN		
103	NO ASSIGN		
104	NO ASSIGN		
105	NO ASSIGN		
106	NO ASSIGN		
107	NO ASSIGN		
108	NO ASSIGN		
109	NO ASSIGN		
110	NO ASSIGN		
111	NO ASSIGN		
112	NO ASSIGN		
113	NO ASSIGN		
114	NO ASSIGN		
115	NO ASSIGN		
116	NO ASSIGN		
117	NO ASSIGN		
118	NO ASSIGN		
119	NO ASSIGN		

**CHANNEL8**

#	HIGH	MID	LOW
0	NO ASSIGN		
1	EQ	ATT H	INPUT73
2	EQ	ATT H	INPUT74
3	EQ	ATT H	INPUT75
4	EQ	ATT H	INPUT76
5	EQ	ATT H	INPUT77
6	EQ	ATT H	INPUT78
7	EQ	ATT H	INPUT79
8	EQ	ATT H	INPUT80
9	EQ	ATT H	INPUT81
10	EQ	ATT H	INPUT82
11	EQ	ATT H	INPUT83
12	EQ	ATT H	INPUT84
13	EQ	ATT H	INPUT85
14	EQ	ATT H	INPUT86
15	EQ	ATT H	INPUT87
16	EQ	ATT H	INPUT88
17	EQ	ATT H	INPUT89
18	EQ	ATT H	INPUT90
19	EQ	ATT H	INPUT91
20	EQ	ATT H	INPUT92
21	EQ	ATT H	INPUT93
22	EQ	ATT H	INPUT94
23	EQ	ATT H	INPUT95
24	EQ	ATT H	INPUT96
25	EQ	ATT H	MATRIX1
26	EQ	ATT H	MATRIX2
27	EQ	ATT H	MATRIX3
28	EQ	ATT H	MATRIX4
29	EQ	ATT H	STEREO
30	NO ASSIGN		
31	NO ASSIGN		
32	NO ASSIGN		
33	EQ	ATT L	INPUT73
34	EQ	ATT L	INPUT74
35	EQ	ATT L	INPUT75
36	EQ	ATT L	INPUT76
37	EQ	ATT L	INPUT77
38	EQ	ATT L	INPUT78
39	EQ	ATT L	INPUT79
40	EQ	ATT L	INPUT80
41	EQ	ATT L	INPUT81
42	EQ	ATT L	INPUT82
43	EQ	ATT L	INPUT83
44	EQ	ATT L	INPUT84
45	EQ	ATT L	INPUT85
46	EQ	ATT L	INPUT86
47	EQ	ATT L	INPUT87
48	EQ	ATT L	INPUT88
49	EQ	ATT L	INPUT89
50	EQ	ATT L	INPUT90
51	EQ	ATT L	INPUT91
52	EQ	ATT L	INPUT92
53	EQ	ATT L	INPUT93
54	EQ	ATT L	INPUT94
55	EQ	ATT L	INPUT95
56	EQ	ATT L	INPUT96

#	HIGH	MID	LOW
57	EQ	ATT L	MATRIX1
58	EQ	ATT L	MATRIX2
59	EQ	ATT L	MATRIX3
60	EQ	ATT L	MATRIX4
61	EQ	ATT L	STEREO
62	NO ASSIGN		
63	NO ASSIGN		
64	EQ	ON	INPUT73
65	EQ	ON	INPUT74
66	EQ	ON	INPUT75
67	EQ	ON	INPUT76
68	EQ	ON	INPUT77
69	EQ	ON	INPUT78
70	EQ	ON	INPUT79
71	EQ	ON	INPUT80
72	EQ	ON	INPUT81
73	EQ	ON	INPUT82
74	EQ	ON	INPUT83
75	EQ	ON	INPUT84
76	EQ	ON	INPUT85
77	EQ	ON	INPUT86
78	EQ	ON	INPUT87
79	EQ	ON	INPUT88
80	EQ	ON	INPUT89
81	EQ	ON	INPUT90
82	EQ	ON	INPUT91
83	EQ	ON	INPUT92
84	EQ	ON	INPUT93
85	EQ	ON	INPUT94
86	EQ	ON	INPUT95
87	EQ	ON	INPUT96
88	NO ASSIGN		
89	NO ASSIGN		
90	NO ASSIGN		
91	NO ASSIGN		
92	NO ASSIGN		
93	NO ASSIGN		
94	NO ASSIGN		
95	NO ASSIGN		
102	NO ASSIGN		
103	NO ASSIGN		
104	NO ASSIGN		
105	NO ASSIGN		
106	NO ASSIGN		
107	NO ASSIGN		
108	NO ASSIGN		
109	NO ASSIGN		
110	NO ASSIGN		
111	NO ASSIGN		
112	NO ASSIGN		
113	NO ASSIGN		
114	NO ASSIGN		
115	NO ASSIGN		
116	NO ASSIGN		
117	NO ASSIGN		
118	NO ASSIGN		
119	NO ASSIGN		



## CHANNEL9

#	HIGH	MID	LOW
0	NO ASSIGN		
1	SURROUND	LFE H	INPUT1
2	SURROUND	LFE H	INPUT2
3	SURROUND	LFE H	INPUT3
4	SURROUND	LFE H	INPUT4
5	SURROUND	LFE H	INPUT5
6	SURROUND	LFE H	INPUT6
7	SURROUND	LFE H	INPUT7
8	SURROUND	LFE H	INPUT8
9	SURROUND	LFE H	INPUT9
10	SURROUND	LFE H	INPUT10
11	SURROUND	LFE H	INPUT11
12	SURROUND	LFE H	INPUT12
13	SURROUND	LFE H	INPUT13
14	SURROUND	LFE H	INPUT14
15	SURROUND	LFE H	INPUT15
16	SURROUND	LFE H	INPUT16
17	SURROUND	LFE H	INPUT17
18	SURROUND	LFE H	INPUT18
19	SURROUND	LFE H	INPUT19
20	SURROUND	LFE H	INPUT20
21	SURROUND	LFE H	INPUT21
22	SURROUND	LFE H	INPUT22
23	SURROUND	LFE H	INPUT23
24	SURROUND	LFE H	INPUT24
25	NO ASSIGN		
26	NO ASSIGN		
27	NO ASSIGN		
28	NO ASSIGN		
29	NO ASSIGN		
30	NO ASSIGN		
31	NO ASSIGN		
32	NO ASSIGN		
33	SURROUND	LFE L	INPUT1
34	SURROUND	LFE L	INPUT2
35	SURROUND	LFE L	INPUT3
36	SURROUND	LFE L	INPUT4
37	SURROUND	LFE L	INPUT5
38	SURROUND	LFE L	INPUT6
39	SURROUND	LFE L	INPUT7
40	SURROUND	LFE L	INPUT8
41	SURROUND	LFE L	INPUT9
42	SURROUND	LFE L	INPUT10
43	SURROUND	LFE L	INPUT11
44	SURROUND	LFE L	INPUT12
45	SURROUND	LFE L	INPUT13
46	SURROUND	LFE L	INPUT14
47	SURROUND	LFE L	INPUT15
48	SURROUND	LFE L	INPUT16
49	SURROUND	LFE L	INPUT17
50	SURROUND	LFE L	INPUT18
51	SURROUND	LFE L	INPUT19
52	SURROUND	LFE L	INPUT20
53	SURROUND	LFE L	INPUT21
54	SURROUND	LFE L	INPUT22
55	SURROUND	LFE L	INPUT23
56	SURROUND	LFE L	INPUT24

#	HIGH	MID	LOW
57	NO ASSIGN		
58	NO ASSIGN		
59	NO ASSIGN		
60	NO ASSIGN		
61	NO ASSIGN		
62	NO ASSIGN		
63	NO ASSIGN		
64	SURROUND	DIV F	INPUT1
65	SURROUND	DIV F	INPUT2
66	SURROUND	DIV F	INPUT3
67	SURROUND	DIV F	INPUT4
68	SURROUND	DIV F	INPUT5
69	SURROUND	DIV F	INPUT6
70	SURROUND	DIV F	INPUT7
71	SURROUND	DIV F	INPUT8
72	SURROUND	DIV F	INPUT9
73	SURROUND	DIV F	INPUT10
74	SURROUND	DIV F	INPUT11
75	SURROUND	DIV F	INPUT12
76	SURROUND	DIV F	INPUT13
77	SURROUND	DIV F	INPUT14
78	SURROUND	DIV F	INPUT15
79	SURROUND	DIV F	INPUT16
80	SURROUND	DIV F	INPUT17
81	SURROUND	DIV F	INPUT18
82	SURROUND	DIV F	INPUT19
83	SURROUND	DIV F	INPUT20
84	SURROUND	DIV F	INPUT21
85	SURROUND	DIV F	INPUT22
86	SURROUND	DIV F	INPUT23
87	SURROUND	DIV F	INPUT24
88	NO ASSIGN		
89	SURROUND	DIV R	INPUT1
90	SURROUND	DIV R	INPUT2
91	SURROUND	DIV R	INPUT3
92	SURROUND	DIV R	INPUT4
93	SURROUND	DIV R	INPUT5
94	SURROUND	DIV R	INPUT6
95	SURROUND	DIV R	INPUT7
102	SURROUND	DIV R	INPUT8
103	SURROUND	DIV R	INPUT9
104	SURROUND	DIV R	INPUT10
105	SURROUND	DIV R	INPUT11
106	SURROUND	DIV R	INPUT12
107	SURROUND	DIV R	INPUT13
108	SURROUND	DIV R	INPUT14
109	SURROUND	DIV R	INPUT15
110	SURROUND	DIV R	INPUT16
111	SURROUND	DIV R	INPUT17
112	SURROUND	DIV R	INPUT18
113	SURROUND	DIV R	INPUT19
114	SURROUND	DIV R	INPUT20
115	SURROUND	DIV R	INPUT21
116	SURROUND	DIV R	INPUT22
117	SURROUND	DIV R	INPUT23
118	SURROUND	DIV R	INPUT24
119	NO ASSIGN		

**CHANNEL10**

#	HIGH	MID	LOW
0	NO ASSIGN		
1	SURROUND	LFE H	INPUT25
2	SURROUND	LFE H	INPUT26
3	SURROUND	LFE H	INPUT27
4	SURROUND	LFE H	INPUT28
5	SURROUND	LFE H	INPUT29
6	SURROUND	LFE H	INPUT30
7	SURROUND	LFE H	INPUT31
8	SURROUND	LFE H	INPUT32
9	SURROUND	LFE H	INPUT33
10	SURROUND	LFE H	INPUT34
11	SURROUND	LFE H	INPUT35
12	SURROUND	LFE H	INPUT36
13	SURROUND	LFE H	INPUT37
14	SURROUND	LFE H	INPUT38
15	SURROUND	LFE H	INPUT39
16	SURROUND	LFE H	INPUT40
17	SURROUND	LFE H	INPUT41
18	SURROUND	LFE H	INPUT42
19	SURROUND	LFE H	INPUT43
20	SURROUND	LFE H	INPUT44
21	SURROUND	LFE H	INPUT45
22	SURROUND	LFE H	INPUT46
23	SURROUND	LFE H	INPUT47
24	SURROUND	LFE H	INPUT48
25	NO ASSIGN		
26	NO ASSIGN		
27	NO ASSIGN		
28	NO ASSIGN		
29	NO ASSIGN		
30	NO ASSIGN		
31	NO ASSIGN		
32	NO ASSIGN		
33	SURROUND	LFE L	INPUT25
34	SURROUND	LFE L	INPUT26
35	SURROUND	LFE L	INPUT27
36	SURROUND	LFE L	INPUT28
37	SURROUND	LFE L	INPUT29
38	SURROUND	LFE L	INPUT30
39	SURROUND	LFE L	INPUT31
40	SURROUND	LFE L	INPUT32
41	SURROUND	LFE L	INPUT33
42	SURROUND	LFE L	INPUT34
43	SURROUND	LFE L	INPUT35
44	SURROUND	LFE L	INPUT36
45	SURROUND	LFE L	INPUT37
46	SURROUND	LFE L	INPUT38
47	SURROUND	LFE L	INPUT39
48	SURROUND	LFE L	INPUT40
49	SURROUND	LFE L	INPUT41
50	SURROUND	LFE L	INPUT42
51	SURROUND	LFE L	INPUT43
52	SURROUND	LFE L	INPUT44
53	SURROUND	LFE L	INPUT45
54	SURROUND	LFE L	INPUT46
55	SURROUND	LFE L	INPUT47
56	SURROUND	LFE L	INPUT48

#	HIGH	MID	LOW
57	NO ASSIGN		
58	NO ASSIGN		
59	NO ASSIGN		
60	NO ASSIGN		
61	NO ASSIGN		
62	NO ASSIGN		
63	NO ASSIGN		
64	SURROUND	DIV F	INPUT25
65	SURROUND	DIV F	INPUT26
66	SURROUND	DIV F	INPUT27
67	SURROUND	DIV F	INPUT28
68	SURROUND	DIV F	INPUT29
69	SURROUND	DIV F	INPUT30
70	SURROUND	DIV F	INPUT31
71	SURROUND	DIV F	INPUT32
72	SURROUND	DIV F	INPUT33
73	SURROUND	DIV F	INPUT34
74	SURROUND	DIV F	INPUT35
75	SURROUND	DIV F	INPUT36
76	SURROUND	DIV F	INPUT37
77	SURROUND	DIV F	INPUT38
78	SURROUND	DIV F	INPUT39
79	SURROUND	DIV F	INPUT40
80	SURROUND	DIV F	INPUT41
81	SURROUND	DIV F	INPUT42
82	SURROUND	DIV F	INPUT43
83	SURROUND	DIV F	INPUT44
84	SURROUND	DIV F	INPUT45
85	SURROUND	DIV F	INPUT46
86	SURROUND	DIV F	INPUT47
87	SURROUND	DIV F	INPUT48
88	NO ASSIGN		
89	SURROUND	DIV R	INPUT25
90	SURROUND	DIV R	INPUT26
91	SURROUND	DIV R	INPUT27
92	SURROUND	DIV R	INPUT28
93	SURROUND	DIV R	INPUT29
94	SURROUND	DIV R	INPUT30
95	SURROUND	DIV R	INPUT31
102	SURROUND	DIV R	INPUT32
103	SURROUND	DIV R	INPUT33
104	SURROUND	DIV R	INPUT34
105	SURROUND	DIV R	INPUT35
106	SURROUND	DIV R	INPUT36
107	SURROUND	DIV R	INPUT37
108	SURROUND	DIV R	INPUT38
109	SURROUND	DIV R	INPUT39
110	SURROUND	DIV R	INPUT40
111	SURROUND	DIV R	INPUT41
112	SURROUND	DIV R	INPUT42
113	SURROUND	DIV R	INPUT43
114	SURROUND	DIV R	INPUT44
115	SURROUND	DIV R	INPUT45
116	SURROUND	DIV R	INPUT46
117	SURROUND	DIV R	INPUT47
118	SURROUND	DIV R	INPUT48
119	NO ASSIGN		

## CHANNEL11

#	HIGH	MID	LOW
0	NO ASSIGN		
1	SURROUND	LFE H	INPUT49
2	SURROUND	LFE H	INPUT50
3	SURROUND	LFE H	INPUT51
4	SURROUND	LFE H	INPUT52
5	SURROUND	LFE H	INPUT53
6	SURROUND	LFE H	INPUT54
7	SURROUND	LFE H	INPUT55
8	SURROUND	LFE H	INPUT56
9	SURROUND	LFE H	INPUT57
10	SURROUND	LFE H	INPUT58
11	SURROUND	LFE H	INPUT59
12	SURROUND	LFE H	INPUT60
13	SURROUND	LFE H	INPUT61
14	SURROUND	LFE H	INPUT62
15	SURROUND	LFE H	INPUT63
16	SURROUND	LFE H	INPUT64
17	SURROUND	LFE H	INPUT65
18	SURROUND	LFE H	INPUT66
19	SURROUND	LFE H	INPUT67
20	SURROUND	LFE H	INPUT68
21	SURROUND	LFE H	INPUT69
22	SURROUND	LFE H	INPUT70
23	SURROUND	LFE H	INPUT71
24	SURROUND	LFE H	INPUT72
25	NO ASSIGN		
26	NO ASSIGN		
27	NO ASSIGN		
28	NO ASSIGN		
29	NO ASSIGN		
30	NO ASSIGN		
31	NO ASSIGN		
32	NO ASSIGN		
33	SURROUND	LFE L	INPUT49
34	SURROUND	LFE L	INPUT50
35	SURROUND	LFE L	INPUT51
36	SURROUND	LFE L	INPUT52
37	SURROUND	LFE L	INPUT53
38	SURROUND	LFE L	INPUT54
39	SURROUND	LFE L	INPUT55
40	SURROUND	LFE L	INPUT56
41	SURROUND	LFE L	INPUT57
42	SURROUND	LFE L	INPUT58
43	SURROUND	LFE L	INPUT59
44	SURROUND	LFE L	INPUT60
45	SURROUND	LFE L	INPUT61
46	SURROUND	LFE L	INPUT62
47	SURROUND	LFE L	INPUT63
48	SURROUND	LFE L	INPUT64
49	SURROUND	LFE L	INPUT65
50	SURROUND	LFE L	INPUT66
51	SURROUND	LFE L	INPUT67
52	SURROUND	LFE L	INPUT68
53	SURROUND	LFE L	INPUT69
54	SURROUND	LFE L	INPUT70
55	SURROUND	LFE L	INPUT71
56	SURROUND	LFE L	INPUT72

#	HIGH	MID	LOW
57	NO ASSIGN		
58	NO ASSIGN		
59	NO ASSIGN		
60	NO ASSIGN		
61	NO ASSIGN		
62	NO ASSIGN		
63	NO ASSIGN		
64	SURROUND	DIV F	INPUT49
65	SURROUND	DIV F	INPUT50
66	SURROUND	DIV F	INPUT51
67	SURROUND	DIV F	INPUT52
68	SURROUND	DIV F	INPUT53
69	SURROUND	DIV F	INPUT54
70	SURROUND	DIV F	INPUT55
71	SURROUND	DIV F	INPUT56
72	SURROUND	DIV F	INPUT57
73	SURROUND	DIV F	INPUT58
74	SURROUND	DIV F	INPUT59
75	SURROUND	DIV F	INPUT60
76	SURROUND	DIV F	INPUT61
77	SURROUND	DIV F	INPUT62
78	SURROUND	DIV F	INPUT63
79	SURROUND	DIV F	INPUT64
80	SURROUND	DIV F	INPUT65
81	SURROUND	DIV F	INPUT66
82	SURROUND	DIV F	INPUT67
83	SURROUND	DIV F	INPUT68
84	SURROUND	DIV F	INPUT69
85	SURROUND	DIV F	INPUT70
86	SURROUND	DIV F	INPUT71
87	SURROUND	DIV F	INPUT72
88	NO ASSIGN		
89	SURROUND	DIV R	INPUT49
90	SURROUND	DIV R	INPUT50
91	SURROUND	DIV R	INPUT51
92	SURROUND	DIV R	INPUT52
93	SURROUND	DIV R	INPUT53
94	SURROUND	DIV R	INPUT54
95	SURROUND	DIV R	INPUT55
102	SURROUND	DIV R	INPUT56
103	SURROUND	DIV R	INPUT57
104	SURROUND	DIV R	INPUT58
105	SURROUND	DIV R	INPUT59
106	SURROUND	DIV R	INPUT60
107	SURROUND	DIV R	INPUT61
108	SURROUND	DIV R	INPUT62
109	SURROUND	DIV R	INPUT63
110	SURROUND	DIV R	INPUT64
111	SURROUND	DIV R	INPUT65
112	SURROUND	DIV R	INPUT66
113	SURROUND	DIV R	INPUT67
114	SURROUND	DIV R	INPUT68
115	SURROUND	DIV R	INPUT69
116	SURROUND	DIV R	INPUT70
117	SURROUND	DIV R	INPUT71
118	SURROUND	DIV R	INPUT72
119	NO ASSIGN		

**CHANNEL12**

#	HIGH	MID	LOW
0	NO ASSIGN		
1	SURROUND	LFE H	INPUT73
2	SURROUND	LFE H	INPUT74
3	SURROUND	LFE H	INPUT75
4	SURROUND	LFE H	INPUT76
5	SURROUND	LFE H	INPUT77
6	SURROUND	LFE H	INPUT78
7	SURROUND	LFE H	INPUT79
8	SURROUND	LFE H	INPUT80
9	SURROUND	LFE H	INPUT81
10	SURROUND	LFE H	INPUT82
11	SURROUND	LFE H	INPUT83
12	SURROUND	LFE H	INPUT84
13	SURROUND	LFE H	INPUT85
14	SURROUND	LFE H	INPUT86
15	SURROUND	LFE H	INPUT87
16	SURROUND	LFE H	INPUT88
17	SURROUND	LFE H	INPUT89
18	SURROUND	LFE H	INPUT90
19	SURROUND	LFE H	INPUT91
20	SURROUND	LFE H	INPUT92
21	SURROUND	LFE H	INPUT93
22	SURROUND	LFE H	INPUT94
23	SURROUND	LFE H	INPUT95
24	SURROUND	LFE H	INPUT96
25	NO ASSIGN		
26	NO ASSIGN		
27	NO ASSIGN		
28	NO ASSIGN		
29	NO ASSIGN		
30	NO ASSIGN		
31	NO ASSIGN		
32	NO ASSIGN		
33	SURROUND	LFE L	INPUT73
34	SURROUND	LFE L	INPUT74
35	SURROUND	LFE L	INPUT75
36	SURROUND	LFE L	INPUT76
37	SURROUND	LFE L	INPUT77
38	SURROUND	LFE L	INPUT78
39	SURROUND	LFE L	INPUT79
40	SURROUND	LFE L	INPUT80
41	SURROUND	LFE L	INPUT81
42	SURROUND	LFE L	INPUT82
43	SURROUND	LFE L	INPUT83
44	SURROUND	LFE L	INPUT84
45	SURROUND	LFE L	INPUT85
46	SURROUND	LFE L	INPUT86
47	SURROUND	LFE L	INPUT87
48	SURROUND	LFE L	INPUT88
49	SURROUND	LFE L	INPUT89
50	SURROUND	LFE L	INPUT90
51	SURROUND	LFE L	INPUT91
52	SURROUND	LFE L	INPUT92
53	SURROUND	LFE L	INPUT93
54	SURROUND	LFE L	INPUT94
55	SURROUND	LFE L	INPUT95
56	SURROUND	LFE L	INPUT96

#	HIGH	MID	LOW
57	NO ASSIGN		
58	NO ASSIGN		
59	NO ASSIGN		
60	NO ASSIGN		
61	NO ASSIGN		
62	NO ASSIGN		
63	NO ASSIGN		
64	SURROUND	DIV F	INPUT73
65	SURROUND	DIV F	INPUT74
66	SURROUND	DIV F	INPUT75
67	SURROUND	DIV F	INPUT76
68	SURROUND	DIV F	INPUT77
69	SURROUND	DIV F	INPUT78
70	SURROUND	DIV F	INPUT79
71	SURROUND	DIV F	INPUT80
72	SURROUND	DIV F	INPUT81
73	SURROUND	DIV F	INPUT82
74	SURROUND	DIV F	INPUT83
75	SURROUND	DIV F	INPUT84
76	SURROUND	DIV F	INPUT85
77	SURROUND	DIV F	INPUT86
78	SURROUND	DIV F	INPUT87
79	SURROUND	DIV F	INPUT88
80	SURROUND	DIV F	INPUT89
81	SURROUND	DIV F	INPUT90
82	SURROUND	DIV F	INPUT91
83	SURROUND	DIV F	INPUT92
84	SURROUND	DIV F	INPUT93
85	SURROUND	DIV F	INPUT94
86	SURROUND	DIV F	INPUT95
87	SURROUND	DIV F	INPUT96
88	NO ASSIGN		
89	SURROUND	DIV R	INPUT73
90	SURROUND	DIV R	INPUT74
91	SURROUND	DIV R	INPUT75
92	SURROUND	DIV R	INPUT76
93	SURROUND	DIV R	INPUT77
94	SURROUND	DIV R	INPUT78
95	SURROUND	DIV R	INPUT79
102	SURROUND	DIV R	INPUT80
103	SURROUND	DIV R	INPUT81
104	SURROUND	DIV R	INPUT82
105	SURROUND	DIV R	INPUT83
106	SURROUND	DIV R	INPUT84
107	SURROUND	DIV R	INPUT85
108	SURROUND	DIV R	INPUT86
109	SURROUND	DIV R	INPUT87
110	SURROUND	DIV R	INPUT88
111	SURROUND	DIV R	INPUT89
112	SURROUND	DIV R	INPUT90
113	SURROUND	DIV R	INPUT91
114	SURROUND	DIV R	INPUT92
115	SURROUND	DIV R	INPUT93
116	SURROUND	DIV R	INPUT94
117	SURROUND	DIV R	INPUT95
118	SURROUND	DIV R	INPUT96
119	NO ASSIGN		

## CHANNEL13

#	HIGH	MID	LOW
0	NO ASSIGN		
1	SURROUND	LR	INPUT1
2	SURROUND	LR	INPUT2
3	SURROUND	LR	INPUT3
4	SURROUND	LR	INPUT4
5	SURROUND	LR	INPUT5
6	SURROUND	LR	INPUT6
7	SURROUND	LR	INPUT7
8	SURROUND	LR	INPUT8
9	SURROUND	LR	INPUT9
10	SURROUND	LR	INPUT10
11	SURROUND	LR	INPUT11
12	SURROUND	LR	INPUT12
13	SURROUND	LR	INPUT13
14	SURROUND	LR	INPUT14
15	SURROUND	LR	INPUT15
16	SURROUND	LR	INPUT16
17	SURROUND	LR	INPUT17
18	SURROUND	LR	INPUT18
19	SURROUND	LR	INPUT19
20	SURROUND	LR	INPUT20
21	SURROUND	LR	INPUT21
22	SURROUND	LR	INPUT22
23	SURROUND	LR	INPUT23
24	SURROUND	LR	INPUT24
25	NO ASSIGN		
26	NO ASSIGN		
27	NO ASSIGN		
28	NO ASSIGN		
29	NO ASSIGN		
30	NO ASSIGN		
31	NO ASSIGN		
32	NO ASSIGN		
33	SURROUND	FR	INPUT1
34	SURROUND	FR	INPUT2
35	SURROUND	FR	INPUT3
36	SURROUND	FR	INPUT4
37	SURROUND	FR	INPUT5
38	SURROUND	FR	INPUT6
39	SURROUND	FR	INPUT7
40	SURROUND	FR	INPUT8
41	SURROUND	FR	INPUT9
42	SURROUND	FR	INPUT10
43	SURROUND	FR	INPUT11
44	SURROUND	FR	INPUT12
45	SURROUND	FR	INPUT13
46	SURROUND	FR	INPUT14
47	SURROUND	FR	INPUT15
48	SURROUND	FR	INPUT16
49	SURROUND	FR	INPUT17
50	SURROUND	FR	INPUT18
51	SURROUND	FR	INPUT19
52	SURROUND	FR	INPUT20
53	SURROUND	FR	INPUT21
54	SURROUND	FR	INPUT22
55	SURROUND	FR	INPUT23
56	SURROUND	FR	INPUT24

#	HIGH	MID	LOW
57	NO ASSIGN		
58	NO ASSIGN		
59	NO ASSIGN		
60	NO ASSIGN		
61	NO ASSIGN		
62	NO ASSIGN		
63	NO ASSIGN		
64	SURROUND	WIDTH	INPUT1
65	SURROUND	WIDTH	INPUT2
66	SURROUND	WIDTH	INPUT3
67	SURROUND	WIDTH	INPUT4
68	SURROUND	WIDTH	INPUT5
69	SURROUND	WIDTH	INPUT6
70	SURROUND	WIDTH	INPUT7
71	SURROUND	WIDTH	INPUT8
72	SURROUND	WIDTH	INPUT9
73	SURROUND	WIDTH	INPUT10
74	SURROUND	WIDTH	INPUT11
75	SURROUND	WIDTH	INPUT12
76	SURROUND	WIDTH	INPUT13
77	SURROUND	WIDTH	INPUT14
78	SURROUND	WIDTH	INPUT15
79	SURROUND	WIDTH	INPUT16
80	SURROUND	WIDTH	INPUT17
81	SURROUND	WIDTH	INPUT18
82	SURROUND	WIDTH	INPUT19
83	SURROUND	WIDTH	INPUT20
84	SURROUND	WIDTH	INPUT21
85	SURROUND	WIDTH	INPUT22
86	SURROUND	WIDTH	INPUT23
87	SURROUND	WIDTH	INPUT24
88	NO ASSIGN		
89	SURROUND	DEPTH	INPUT1
90	SURROUND	DEPTH	INPUT2
91	SURROUND	DEPTH	INPUT3
92	SURROUND	DEPTH	INPUT4
93	SURROUND	DEPTH	INPUT5
94	SURROUND	DEPTH	INPUT6
95	SURROUND	DEPTH	INPUT7
102	SURROUND	DEPTH	INPUT8
103	SURROUND	DEPTH	INPUT9
104	SURROUND	DEPTH	INPUT10
105	SURROUND	DEPTH	INPUT11
106	SURROUND	DEPTH	INPUT12
107	SURROUND	DEPTH	INPUT13
108	SURROUND	DEPTH	INPUT14
109	SURROUND	DEPTH	INPUT15
110	SURROUND	DEPTH	INPUT16
111	SURROUND	DEPTH	INPUT17
112	SURROUND	DEPTH	INPUT18
113	SURROUND	DEPTH	INPUT19
114	SURROUND	DEPTH	INPUT20
115	SURROUND	DEPTH	INPUT21
116	SURROUND	DEPTH	INPUT22
117	SURROUND	DEPTH	INPUT23
118	SURROUND	DEPTH	INPUT24
119	NO ASSIGN		

## CHANNEL14

#	HIGH	MID	LOW
0	NO ASSIGN		
1	SURROUND	LR	INPUT25
2	SURROUND	LR	INPUT26
3	SURROUND	LR	INPUT27
4	SURROUND	LR	INPUT28
5	SURROUND	LR	INPUT29
6	SURROUND	LR	INPUT30
7	SURROUND	LR	INPUT31
8	SURROUND	LR	INPUT32
9	SURROUND	LR	INPUT33
10	SURROUND	LR	INPUT34
11	SURROUND	LR	INPUT35
12	SURROUND	LR	INPUT36
13	SURROUND	LR	INPUT37
14	SURROUND	LR	INPUT38
15	SURROUND	LR	INPUT39
16	SURROUND	LR	INPUT40
17	SURROUND	LR	INPUT41
18	SURROUND	LR	INPUT42
19	SURROUND	LR	INPUT43
20	SURROUND	LR	INPUT44
21	SURROUND	LR	INPUT45
22	SURROUND	LR	INPUT46
23	SURROUND	LR	INPUT47
24	SURROUND	LR	INPUT48
25	NO ASSIGN		
26	NO ASSIGN		
27	NO ASSIGN		
28	NO ASSIGN		
29	NO ASSIGN		
30	NO ASSIGN		
31	NO ASSIGN		
32	NO ASSIGN		
33	SURROUND	FR	INPUT25
34	SURROUND	FR	INPUT26
35	SURROUND	FR	INPUT27
36	SURROUND	FR	INPUT28
37	SURROUND	FR	INPUT29
38	SURROUND	FR	INPUT30
39	SURROUND	FR	INPUT31
40	SURROUND	FR	INPUT32
41	SURROUND	FR	INPUT33
42	SURROUND	FR	INPUT34
43	SURROUND	FR	INPUT35
44	SURROUND	FR	INPUT36
45	SURROUND	FR	INPUT37
46	SURROUND	FR	INPUT38
47	SURROUND	FR	INPUT39
48	SURROUND	FR	INPUT40
49	SURROUND	FR	INPUT41
50	SURROUND	FR	INPUT42
51	SURROUND	FR	INPUT43
52	SURROUND	FR	INPUT44
53	SURROUND	FR	INPUT45
54	SURROUND	FR	INPUT46
55	SURROUND	FR	INPUT47
56	SURROUND	FR	INPUT48

#	HIGH	MID	LOW
57	NO ASSIGN		
58	NO ASSIGN		
59	NO ASSIGN		
60	NO ASSIGN		
61	NO ASSIGN		
62	NO ASSIGN		
63	NO ASSIGN		
64	SURROUND	WIDTH	INPUT25
65	SURROUND	WIDTH	INPUT26
66	SURROUND	WIDTH	INPUT27
67	SURROUND	WIDTH	INPUT28
68	SURROUND	WIDTH	INPUT29
69	SURROUND	WIDTH	INPUT30
70	SURROUND	WIDTH	INPUT31
71	SURROUND	WIDTH	INPUT32
72	SURROUND	WIDTH	INPUT33
73	SURROUND	WIDTH	INPUT34
74	SURROUND	WIDTH	INPUT35
75	SURROUND	WIDTH	INPUT36
76	SURROUND	WIDTH	INPUT37
77	SURROUND	WIDTH	INPUT38
78	SURROUND	WIDTH	INPUT39
79	SURROUND	WIDTH	INPUT40
80	SURROUND	WIDTH	INPUT41
81	SURROUND	WIDTH	INPUT42
82	SURROUND	WIDTH	INPUT43
83	SURROUND	WIDTH	INPUT44
84	SURROUND	WIDTH	INPUT45
85	SURROUND	WIDTH	INPUT46
86	SURROUND	WIDTH	INPUT47
87	SURROUND	WIDTH	INPUT48
88	NO ASSIGN		
89	SURROUND	DEPTH	INPUT25
90	SURROUND	DEPTH	INPUT26
91	SURROUND	DEPTH	INPUT27
92	SURROUND	DEPTH	INPUT28
93	SURROUND	DEPTH	INPUT29
94	SURROUND	DEPTH	INPUT30
95	SURROUND	DEPTH	INPUT31
102	SURROUND	DEPTH	INPUT32
103	SURROUND	DEPTH	INPUT33
104	SURROUND	DEPTH	INPUT34
105	SURROUND	DEPTH	INPUT35
106	SURROUND	DEPTH	INPUT36
107	SURROUND	DEPTH	INPUT37
108	SURROUND	DEPTH	INPUT38
109	SURROUND	DEPTH	INPUT39
110	SURROUND	DEPTH	INPUT40
111	SURROUND	DEPTH	INPUT41
112	SURROUND	DEPTH	INPUT42
113	SURROUND	DEPTH	INPUT43
114	SURROUND	DEPTH	INPUT44
115	SURROUND	DEPTH	INPUT45
116	SURROUND	DEPTH	INPUT46
117	SURROUND	DEPTH	INPUT47
118	SURROUND	DEPTH	INPUT48
119	NO ASSIGN		

## CHANNEL15

#	HIGH	MID	LOW
0	NO ASSIGN		
1	SURROUND	LR	INPUT49
2	SURROUND	LR	INPUT50
3	SURROUND	LR	INPUT51
4	SURROUND	LR	INPUT52
5	SURROUND	LR	INPUT53
6	SURROUND	LR	INPUT54
7	SURROUND	LR	INPUT55
8	SURROUND	LR	INPUT56
9	SURROUND	LR	INPUT57
10	SURROUND	LR	INPUT58
11	SURROUND	LR	INPUT59
12	SURROUND	LR	INPUT60
13	SURROUND	LR	INPUT61
14	SURROUND	LR	INPUT62
15	SURROUND	LR	INPUT63
16	SURROUND	LR	INPUT64
17	SURROUND	LR	INPUT65
18	SURROUND	LR	INPUT66
19	SURROUND	LR	INPUT67
20	SURROUND	LR	INPUT68
21	SURROUND	LR	INPUT69
22	SURROUND	LR	INPUT70
23	SURROUND	LR	INPUT71
24	SURROUND	LR	INPUT72
25	NO ASSIGN		
26	NO ASSIGN		
27	NO ASSIGN		
28	NO ASSIGN		
29	NO ASSIGN		
30	NO ASSIGN		
31	NO ASSIGN		
32	NO ASSIGN		
33	SURROUND	FR	INPUT49
34	SURROUND	FR	INPUT50
35	SURROUND	FR	INPUT51
36	SURROUND	FR	INPUT52
37	SURROUND	FR	INPUT53
38	SURROUND	FR	INPUT54
39	SURROUND	FR	INPUT55
40	SURROUND	FR	INPUT56
41	SURROUND	FR	INPUT57
42	SURROUND	FR	INPUT58
43	SURROUND	FR	INPUT59
44	SURROUND	FR	INPUT60
45	SURROUND	FR	INPUT61
46	SURROUND	FR	INPUT62
47	SURROUND	FR	INPUT63
48	SURROUND	FR	INPUT64
49	SURROUND	FR	INPUT65
50	SURROUND	FR	INPUT66
51	SURROUND	FR	INPUT67
52	SURROUND	FR	INPUT68
53	SURROUND	FR	INPUT69
54	SURROUND	FR	INPUT70
55	SURROUND	FR	INPUT71
56	SURROUND	FR	INPUT72

#	HIGH	MID	LOW
57	NO ASSIGN		
58	NO ASSIGN		
59	NO ASSIGN		
60	NO ASSIGN		
61	NO ASSIGN		
62	NO ASSIGN		
63	NO ASSIGN		
64	SURROUND	WIDTH	INPUT49
65	SURROUND	WIDTH	INPUT50
66	SURROUND	WIDTH	INPUT51
67	SURROUND	WIDTH	INPUT52
68	SURROUND	WIDTH	INPUT53
69	SURROUND	WIDTH	INPUT54
70	SURROUND	WIDTH	INPUT55
71	SURROUND	WIDTH	INPUT56
72	SURROUND	WIDTH	INPUT57
73	SURROUND	WIDTH	INPUT58
74	SURROUND	WIDTH	INPUT59
75	SURROUND	WIDTH	INPUT60
76	SURROUND	WIDTH	INPUT61
77	SURROUND	WIDTH	INPUT62
78	SURROUND	WIDTH	INPUT63
79	SURROUND	WIDTH	INPUT64
80	SURROUND	WIDTH	INPUT65
81	SURROUND	WIDTH	INPUT66
82	SURROUND	WIDTH	INPUT67
83	SURROUND	WIDTH	INPUT68
84	SURROUND	WIDTH	INPUT69
85	SURROUND	WIDTH	INPUT70
86	SURROUND	WIDTH	INPUT71
87	SURROUND	WIDTH	INPUT72
88	NO ASSIGN		
89	SURROUND	DEPTH	INPUT49
90	SURROUND	DEPTH	INPUT50
91	SURROUND	DEPTH	INPUT51
92	SURROUND	DEPTH	INPUT52
93	SURROUND	DEPTH	INPUT53
94	SURROUND	DEPTH	INPUT54
95	SURROUND	DEPTH	INPUT55
102	SURROUND	DEPTH	INPUT56
103	SURROUND	DEPTH	INPUT57
104	SURROUND	DEPTH	INPUT58
105	SURROUND	DEPTH	INPUT59
106	SURROUND	DEPTH	INPUT60
107	SURROUND	DEPTH	INPUT61
108	SURROUND	DEPTH	INPUT62
109	SURROUND	DEPTH	INPUT63
110	SURROUND	DEPTH	INPUT64
111	SURROUND	DEPTH	INPUT65
112	SURROUND	DEPTH	INPUT66
113	SURROUND	DEPTH	INPUT67
114	SURROUND	DEPTH	INPUT68
115	SURROUND	DEPTH	INPUT69
116	SURROUND	DEPTH	INPUT70
117	SURROUND	DEPTH	INPUT71
118	SURROUND	DEPTH	INPUT72
119	NO ASSIGN		

**CHANNEL16**

#	HIGH	MID	LOW
0	NO ASSIGN		
1	SURROUND	LR	INPUT73
2	SURROUND	LR	INPUT74
3	SURROUND	LR	INPUT75
4	SURROUND	LR	INPUT76
5	SURROUND	LR	INPUT77
6	SURROUND	LR	INPUT78
7	SURROUND	LR	INPUT79
8	SURROUND	LR	INPUT80
9	SURROUND	LR	INPUT81
10	SURROUND	LR	INPUT82
11	SURROUND	LR	INPUT83
12	SURROUND	LR	INPUT84
13	SURROUND	LR	INPUT85
14	SURROUND	LR	INPUT86
15	SURROUND	LR	INPUT87
16	SURROUND	LR	INPUT88
17	SURROUND	LR	INPUT89
18	SURROUND	LR	INPUT90
19	SURROUND	LR	INPUT91
20	SURROUND	LR	INPUT92
21	SURROUND	LR	INPUT93
22	SURROUND	LR	INPUT94
23	SURROUND	LR	INPUT95
24	SURROUND	LR	INPUT96
25	NO ASSIGN		
26	NO ASSIGN		
27	NO ASSIGN		
28	NO ASSIGN		
29	NO ASSIGN		
30	NO ASSIGN		
31	NO ASSIGN		
32	NO ASSIGN		
33	SURROUND	FR	INPUT73
34	SURROUND	FR	INPUT74
35	SURROUND	FR	INPUT75
36	SURROUND	FR	INPUT76
37	SURROUND	FR	INPUT77
38	SURROUND	FR	INPUT78
39	SURROUND	FR	INPUT79
40	SURROUND	FR	INPUT80
41	SURROUND	FR	INPUT81
42	SURROUND	FR	INPUT82
43	SURROUND	FR	INPUT83
44	SURROUND	FR	INPUT84
45	SURROUND	FR	INPUT85
46	SURROUND	FR	INPUT86
47	SURROUND	FR	INPUT87
48	SURROUND	FR	INPUT88
49	SURROUND	FR	INPUT89
50	SURROUND	FR	INPUT90
51	SURROUND	FR	INPUT91
52	SURROUND	FR	INPUT92
53	SURROUND	FR	INPUT93
54	SURROUND	FR	INPUT94
55	SURROUND	FR	INPUT95
56	SURROUND	FR	INPUT96

#	HIGH	MID	LOW
57	NO ASSIGN		
58	NO ASSIGN		
59	NO ASSIGN		
60	NO ASSIGN		
61	NO ASSIGN		
62	NO ASSIGN		
63	NO ASSIGN		
64	SURROUND	WIDTH	INPUT73
65	SURROUND	WIDTH	INPUT74
66	SURROUND	WIDTH	INPUT75
67	SURROUND	WIDTH	INPUT76
68	SURROUND	WIDTH	INPUT77
69	SURROUND	WIDTH	INPUT78
70	SURROUND	WIDTH	INPUT79
71	SURROUND	WIDTH	INPUT80
72	SURROUND	WIDTH	INPUT81
73	SURROUND	WIDTH	INPUT82
74	SURROUND	WIDTH	INPUT83
75	SURROUND	WIDTH	INPUT84
76	SURROUND	WIDTH	INPUT85
77	SURROUND	WIDTH	INPUT86
78	SURROUND	WIDTH	INPUT87
79	SURROUND	WIDTH	INPUT88
80	SURROUND	WIDTH	INPUT89
81	SURROUND	WIDTH	INPUT90
82	SURROUND	WIDTH	INPUT91
83	SURROUND	WIDTH	INPUT92
84	SURROUND	WIDTH	INPUT93
85	SURROUND	WIDTH	INPUT94
86	SURROUND	WIDTH	INPUT95
87	SURROUND	WIDTH	INPUT96
88	NO ASSIGN		
89	SURROUND	DEPTH	INPUT73
90	SURROUND	DEPTH	INPUT74
91	SURROUND	DEPTH	INPUT75
92	SURROUND	DEPTH	INPUT76
93	SURROUND	DEPTH	INPUT77
94	SURROUND	DEPTH	INPUT78
95	SURROUND	DEPTH	INPUT79
102	SURROUND	DEPTH	INPUT80
103	SURROUND	DEPTH	INPUT81
104	SURROUND	DEPTH	INPUT82
105	SURROUND	DEPTH	INPUT83
106	SURROUND	DEPTH	INPUT84
107	SURROUND	DEPTH	INPUT85
108	SURROUND	DEPTH	INPUT86
109	SURROUND	DEPTH	INPUT87
110	SURROUND	DEPTH	INPUT88
111	SURROUND	DEPTH	INPUT89
112	SURROUND	DEPTH	INPUT90
113	SURROUND	DEPTH	INPUT91
114	SURROUND	DEPTH	INPUT92
115	SURROUND	DEPTH	INPUT93
116	SURROUND	DEPTH	INPUT94
117	SURROUND	DEPTH	INPUT95
118	SURROUND	DEPTH	INPUT96
119	NO ASSIGN		



# MIDI Data Format

In the following tables, “tx” means that transmission from the DM2000 is possible, and “rx” means that receiving messages at the DM2000 is possible.

## 1. CHANNEL MESSAGE

Command	rx/tx	function
8n NOTE OFF	rx	Control the internal effects
9n NOTE ON	rx	Control the internal effects
Bn CONTROL CHANGE	rx/tx	Control parameters
Cn PROGRAM CHANGE	rx/tx	Switch scene memories

## 2. SYSTEM COMMON MESSAGE

Command	rx/tx	function
F1 MIDI TIME CODE QUARTER FRAME	rx	Used when TIME REFERENCE is MTC.
F2 SONG POSITION POINTER	rx	Used when TIME REFERENCE is MIDI CLOCK.

## 3. SYSTEM REALTIME MESSAGE

Command	rx/tx	function
F8 TIMING CLOCK	rx	MIDI clock
FA START	rx*	Start automix (from the beginning)
FB CONTINUE	rx*	Start automix (from the middle)
FC STOP	rx*	Stop automix
FE ACTIVE SENSING	rx	Check MIDI cable connections
FF SYSTEM RESET	rx	Clear running status

\* Received only when the AUTOMIX TIME REFERENCE setting is set to MIDI CLOCK.

## 4. EXCLUSIVE MESSAGE

The DM2000 can correctly process Exclusive Messages of a length of F0 through F7 of 4096 bytes or shorter.

### 4.1 Real Time System Exclusive

Command	rx/tx	function
F0 7F dd 06 ... F7 MMC COMMAND	tx	MMC command
F0 7F dd 07 ... F7 MMC RESPONSE	rx	MMC response
F0 7F dd 01 ... F7 MIDI TIME CODE	rx	Used when TIME REFERENCE is MTC.

### 4.2 System Exclusive Message

#### 4.2.1 Bulk Dump

Command	rx/tx	function
F0 43 0n 7E ... F7 BULK DUMP DATA	rx/tx	BULK DUMP DATA
F0 43 2n 7E ... F7 BULK DUMP REQUEST	rx/tx	BULK DUMP REQUEST

The following data types of bulk dump are used on the DM2000.

Data name	rx/tx	function
'm'	rx/tx	Scene memory & request (compressed data)
'S'	rx/tx	Setup memory & request
'L'	rx/tx	User defined layer & request
'I'	rx/tx	User defined plug-in & request
'V'	rx/tx	User defined key & request
'U'	rx/tx	User assignable layer & request
'C'	rx/tx	Control change table & request
'P'	rx/tx	Program change table & request
'Q'	rx/tx	Equalizer library & request
'Y'	rx/tx	Compressor library & request
'G'	rx/tx	Gate library & request
'E'	rx/tx	Effect library & request
'F'	rx/tx	GEQ library & request
'H'	rx/tx	Channel library & request
'R'	rx/tx	Input patch library & request
'O'	rx/tx	Output patch library & request
'J'	rx/tx	Bus to stereo library & request
'K'	rx/tx	Surround monitor library & request
'a'	rx/tx	Automix & request (compressed data)
'N'	rx/tx	Plug-in effect card & request

### 4.2.2 PARAMTER CHANGE

Command	rx/tx	function
F0 43 1n 3E 06 ... F7 PARAMETER CHANGE	rx/tx	DM2000-specific parameter change
F0 43 3n 3E 06 ... F7 PARAMETER REQUEST	rx/tx	DM2000-specific parameter request
F0 43 1n 3E 7F ... F7 PARAMETER CHANGE	rx/tx	General purpose digital mixer parameter change
F0 43 3n 3E 7F ... F7 PARAMETER REQUEST	rx/tx	General purpose digital mixer parameter request

The following data types of parameter change are used by the DM2000.

Type (HEX)	rx/tx	function
1 (01)	rx/tx	Edit buffer
2 (02)	rx/tx	Patch data
3 (03)	rx/tx	Setup memory
4 (04)	rx/tx	Backup memory
16 (10)	rx/tx	Function (recall, store, title, clear)
17 (11)	rx	Function (pair)
18 (12)	rx	Function (effect)
19 (13)	rx/tx	Sort table data
20 (14)	rx/tx	Function (attribute, link)
32 (20)	rx	Key remote
33 (21)	rx/tx	Remote meter
34 (22)	rx/tx	Remote time counter
35 (23)	rx/tx	Automix status

### 4.2.3 Card Filer

Command	rx/tx	function
F0 43 5n ... F7 CARD FILER	rx/tx	Packet for card filer

## Format Details

### 1. NOTE OFF (8n)

#### Reception

If [OTHER ECHO] is ON, these message are echoed. If the [Rx CH] matches, these messages are received and used to control effects.

STATUS	1000nnnn	8n	Note off message
DATA	0nnnnnnn	nn	Note number
	0vvvvvvv	vv	Velocity (ignored)

### 2. NOTE ON (9n)

#### Reception

If [OTHER ECHO] is ON, these messages are echoed. If the [Rx CH] matches, these messages are received and used to control effects.

STATUS	1001nnnn	9n	Note on message
DATA	0nnnnnnn	nn	Note number
	0vvvvvvv	vv	Velocity (1-127:on, 0:off)

### 3. CONTROL CHANGE (Bn)

#### Reception

If [Control Change ECHO] is ON, these messages are echoed. If [TABLE] is selected, these message are received if [Control Change Rx] is ON, and will control parameters according to the [Control assign table] settings.

The parameters that can be set are defined in the Control Change Assign Parameter List.

If [NRPN] is selected, these messages are received if [Control Change Rx] is ON and the [Rx CH] matches, and will control the parameter that is specified by the four messages NRPN control number (62h, 63h) and Data Entry control number (06h, 26h). Parameter settings are defined in the Control Change Assign Parameter List.

#### Transmission

If [TABLE] is selected, operating a parameter specified in the [Control assign table] will cause these messages to be transmitted if [Control Change Tx] is ON. The parameters that can be specified are defined in the Control Change Assign Parameter List.

If [NRPN] is selected, operating a specified parameter will cause data to be

transmitted on the [Tx CH] if [Control Change Tx] is ON, using the four messages NRPN control number (62h, 63h) and Data Entry control number (06h, 26h). Parameter settings are defined in the Control Change Assign Parameter List.

This data cannot be transmitted via Program Change to Studio Manager since there is no guarantee that the contents of the tables will match. (Parameter Change messages will always be used.)

#### If [TABLE] is selected

STATUS	1011nnnn	Bn	Control change
DATA	0nnnnnnn	nn	Control number (0-95, 102-119)
	0vvvvvvv	vv	Control Value (0-127)

Formula for converting Control values into parameter data:

```
paramSteps= paramMax - paramMin + 1;
add= paramWidth / paramSteps;
mod= paramWidth - add * paramSteps;
curValue= parm * add + mod / 2;
```

- (1) When the assigned parameter can be set in 128 steps or less:  
paramWidth = 127; rxValue = Control value;
- (2) When the assigned parameter can be set in 128 through 16383 steps:  
paramWidth = 16383;
- (2-1) When both High and Low data are received:  
rxValue = Control value (High) \* 128 + Control value (Low);
- (2-2) When only Low data is received:  
rxValue = (curValue & 16256) + Control value (Low);
- (2-3) When only High data is received:  
rxValue = Control value (High) \* 128 + (curValue & 127);
- (3) When the assigned parameter can be set in 16384 through 2097151 steps:  
paramWidth = 2097151;
- (3-1) When High, Middle, and Low data are received:  
rxValue = Control value (High) \* 16384 + Control value (Middle) \* 128 + Control value (Low);
- (3-2) When only Low data is received:  
rxValue = (curValue & 2097024) + Control value (Low);
- (3-3) When only Middle data is received:  
rxValue = (curValue & 2080895) + Control value (Middle) \* 128;
- (3-4) When only High data is received:  
rxValue = (curValue & 16383) + Control value (High) \* 16384;
- (3-5) When Middle and Low data are received:  
rxValue = (curValue & 2080768) + Control value (Middle) \* 128 + Control value (Low);
- (3-6) When High and Low data are received:  
rxValue = (curValue & 16256) + Control value (High) \* 16384 + Control value (Low);
- (3-7) When High and Middle data are received:  
rxValue = (curValue & 127) + Control value (High) \* 16384 + Control value (Middle) \* 128;  
if (rxValue > paramWidth)  
rxValue = paramWidth;  
param = (rxValue - mod / 2) / add;

#### If [NRPN] is selected

STATUS	1011nnnn	Bn	Control changeDATA
	01100010	62	NRPN LSB
	0vvvvvvv	vv	LSB of parameter number
STATUS	1011nnnn	Bn	Control change*1
DATA	01100011	63	NRPN MSB
	0vvvvvvv	vv	MSB of parameter number
STATUS	1011nnnn	Bn	Control change*1
DATA	00000110	06	MSB of data entry
	0vvvvvvv	vv	MSB of parameter data
STATUS	1011nnnn	Bn	Control change*1
DATA	00100110	26	LSB of data entry
	0vvvvvvv	vv	LSB of parameter data

\*1) The second and subsequent STATUS need not be added during transmission. Reception must be implemented so that reception occurs whether or not STATUS is present.

## 4. PROGRAM CHANGE (Cn)

### Reception

If [Program Change ECHO] is ON, these messages are echoed.

If [Program Change RX] is ON and the [Rx CH] matches, these messages will be received. However if [OMNI] is ON, they will be received regardless of the channel. When a message is received, a Scene Memory will be recalled according to the settings of the [Program Change Table].

### Transmission

If [Program Change TX] is ON, this message is transmitted according to the settings of the [Program Change Table] on the [Tx CH] channel when a scene memory is recalled.

If the recalled scene has been assigned to more than one program number, the lowest-numbered program number will be transmitted. Transmission to Studio Manager using Program Change messages will not be performed since there is no guarantee that the contents of the tables will match. (Parameter Changes will always be used.)

STATUS	1100nnnn	Cn	Program change
DATA	0nnnnnnn	nn	Program number (0-127)

## 5. MIDI TIME CODE QUARTER FRAME(F1)

### Reception

This is echoed if [OTHER COMMANDS ECHO] is ON.

Automix synchronizes this if the data is received at the port specified by the TIME REFERENCE setting.

STATUS	1100nnnn	F1	Quarter frame message
DATA	0tttddd	td	Type & data

## 6. SONG POSITION POINTER (F2)

### Reception

If this is received when the automix TIME REFERENCE setting is MIDI CLOCK, the automix will move to the song position that was received.

STATUS	11110010	F2	Song position pointer
DATA	0vvvvvvv	vv	Song position LSB
	0vvvvvvv	vv	Song position MSB

## 7. TIMING CLOCK (F8)

### Reception

If the automix TIME REFERENCE setting is MIDI CLOCK, this message is used to synchronize automix. It is also used to control effects. This message is transmitted 24 times per quarter note.

STATUS	11111000	F8	Timing clock
--------	----------	----	--------------

## 8. START (FA)

### Reception

This message is received if the automix TIME REFERENCE setting is MIDI CLOCK, and will start the automix. In actuality, automix will start when the next TIMING CLOCK is received after receiving the START message.

STATUS	11111010	FA	Start
--------	----------	----	-------

## 9. CONTINUE (FB)

### Reception

This message is received if the automix TIME REFERENCE setting is MIDI CLOCK, and will cause automix to start from the current song position. In actuality, automix will start when the next TIMING CLOCK is received after receiving the CONTINUE message.

STATUS	11111011	FB	Continue
--------	----------	----	----------

## 10. STOP (FC)

### Reception

This message is received if the automix TIME REFERENCE setting is MIDI CLOCK, and will cause automix to stop.

STATUS	11111100	FC	Stop
--------	----------	----	------

## 11. ACTIVE SENSING (FE)

### Reception

Once this message has been received, the failure to receive any message for an interval of 400 ms or longer will cause MIDI transmission to be initialized, such as by clearing the Running Status.

STATUS 11111110 FE Active sensing

## 12. SYSTEM RESET (FF)

### Reception

When this message is received, MIDI communications will be cleared, e.g., by clearing the Running Status.

STATUS 11111111 FF System reset

## 13. SYSTEM EXCLUSIVE MESSAGE (F0)

### 13.1 MIDI TIME CODE (FULL MESSAGE)

The Automix synchronizes these messages when they are received at a port specified by the TIME REFERENCE setting.

### 13.2 MIDI MACHINE CONTROL (MMC)

These messages are transmitted when the Machine Control section of the DM2000 is operated.

### 13.3 BULK DUMP

This message sends or receives the contents of various memories stored within the DM2000.

The basic format is as follows.

#### For DUMP DATA

F0 43 0n 7E cc cc <Model ID> tt mm mm [Data ...]  
cs F7

#### For DUMP REQUEST

F0 43 2n 7E <Model ID> tt mm mm F7  
n Device Number  
cc cc DATA COUNT (the number of bytes that follow this, ending before the checksum)  
<Model ID> Model ID (for DM2000, 4C 4D 20 20 38 43 31 32)  
tt DATA TYPE  
mm mm DATA NUMBER  
cs CHECK SUM

A unique header (Model ID) is used to determine whether the device is a DM2000.

CHECK SUM is obtained by adding the bytes that follow BYTE COUNT (LOW) and end before CHECK SUM, taking the binary compliment of this sum, and then setting bit 7 to 0.

CHECK SUM = (-sum)&0x7F

The DM2000 can transmit and receive BULK data only if the size of a MIDI packet (F0 - F7) is 4096 bytes or smaller.

If large data consists of multiple MIDI packets, they can be transferred sequentially.

#### Reception

This message is received if [Bulk RX] is ON and the [Rx CH] matches the device number included in the SUB STATUS.

When a bulk dump is received, it is immediately written into the specified memory.

When a bulk dump request is received, a bulk dump is immediately transmitted.

#### Transmission

This message is transmitted on the [Tx CH] by key operations in the [MIDI]-[BULK DUMP] screen.

A bulk dump is transmitted on the [Rx CH] in response to a bulk dump request.

The data area is handled by converting seven words of 8-bit data into eight words of 7-bit data.

### Conversion from actual data into bulk data

```
d[0~6]: actual data
b[0~7]: bulk data
b[0] = 0;
for( I=0; I<7; I++){
    if( d[I]&0x80){
        b[0] |= 1<<((6-I));
    }
    b[I+1] = d[I]&0x7F;
}
```

### Restoration from bulk data into actual data

```
d[0~6]: actual data
b[0~7]: bulk data
for( I=0; I<7; I++){
    b[0] <<= 1;
    d[I] = b[I+1]+(0x80&b[0]);
}
```

### 13.3.1 Scene memory bulk dump format (compressed data)

The DM2000 can transmit and receive scene memories in compressed form.

STATUS	11110000	F0	System exclusive message
ID No.	01000011	43	Manufacture's ID number (YAMAHA)
SUB STATUS	0000nnnn	0n	n=0-15 (Device number=MIDI Channel)
FORMAT No.	01111110	7E	Universal bulk dump
COUNT HIGH	0ccccccc	ch	data count = ch * 128 + cl
COUNT LOW	0ccccccc	cl	
	01001100	4C	'L'
	01001101	4D	'M'
	00100000	20	''
	00100000	20	''
	00111000	38	'8'
	01000011	43	'C'
	00110001	31	'1'
	00110010	32	'2'
DATA NAME	01101101	6D	'm'
	0mmmmmmm	mh	m=0-99, 256, 8192 (Scene0-99, EDIT BUFFER, UNDO)
	0mmmmmmm	ml	Receive is effective 1-99, 256, 8192
BLOCK INFO.	0ttttttt	tt	total block number (minimum number is 0)
	0bbbbbbb	bb	current block number (0-total block number)
DATA	0ddddddd	ds	Scene data of block[bb]
	:		
	:		
	0ddddddd	de	
CHECK SUM	0eeeeeee	ee	ee= (Invert ('L'+...+de)+1)&0x7F
EOX	11110111	F7	End of exclusive

### 13.3.2 Scene memory bulk dump request format (compressed data)

The second and third bytes of the DATA NAME indicate the scene number that is being requested. If this is 256, the data of the Edit Buffer will be bulk-dumped. If this is 8192, the data of the Undo Buffer will be bulk-dumped.

STATUS	11110000	F0	System exclusive message
ID No.	01000011	43	Manufacture's ID number (YAMAHA)
SUB STATUS	0010nnnn	2n	n=0-15 (Device number=MIDI Channel)
FORMAT No.	01111110	7E	Universal bulk dump
	01001100	4C	'L'
	01001101	4D	'M'
	00100000	20	''
	00100000	20	''
	00111000	38	'8'
	01000011	43	'C'
	00110001	31	'1'
	00110010	32	'2'
DATA NAME	01101101	6D	'm'
	0mmmmmmm	mh	m=0-99, 256, 8192 (Scene0-99, EDIT BUFFER, UNDO)

```

00000000 m1
EOX      11110111 F7 End of exclusive

```

### 13.3.3 Setup memory bulk dump format

Of the setup memory of the DM2000, this bulk-dumps data other than the User defined layer, User define plug-in, User defined keys, User assignable layer, Control change table, and Program change table.

```

STATUS      11110000 F0 System exclusive message
ID No.     01000011 43 Manufacture's ID number (YAMAHA)
SUB STATUS  0000nnnn 0n n=0-15 (Device number=MIDI Channel)
FORMAT No. 01111110 7E Universal bulk dump
COUNT HIGH 0ccccccc ch data count = ch * 128 + cl
COUNT LOW 0ccccccc cl

01001100 4C 'L'
01001101 4D 'M'
00100000 20 ''
00100000 20 ''
00111000 38 '8'
01000011 43 'C'
00110001 31 '1'
00110010 32 '2'
DATA NAME  01010011 53 'S'
00000010 02
00000000 00 No.256 = Current
BLOCK INFO. 0ttttttt tt total block number (minimum number
                is 0)
0bbbbbbb bb current block number (0-total block
                number)
DATA       0ddddd ds Setup data of block[bb]
:
:
0ddddd de
CHECK SUM  0eeeeeee ee ee= (Invert ('L'+...+de)+1)&0x7F
EOX      11110111 F7 End of exclusive

```

### 13.3.4 Setup memory bulk dump request format

```

STATUS      11110000 F0 System exclusive message
ID No.     01000011 43 Manufacture's ID number (YAMAHA)
SUB STATUS  0010nnnn 2n n=0-15 (Device number=MIDI Channel)
FORMAT No. 01111110 7E Universal bulk dump
01001100 4C 'L'
01001101 4D 'M'
00100000 20 ''
00100000 20 ''
00111000 38 '8'
01000011 43 'C'
00110001 31 '1'
00110010 32 '2'
DATA NAME  01010011 53 'S'
00000010 02
00000000 00 No.256 = Current
EOX      11110111 F7 End of exclusive

```

### 13.3.5 User defined layer bulk dump format

The second and third bytes of the DATA NAME indicate the bank number.

Be aware that the state of the transmission destination will (in some cases) change if the same bank is being used.

```

STATUS      11110000 F0 System exclusive message
ID No.     01000011 43 Manufacture's ID number (YAMAHA)
SUB STATUS  0000nnnn 0n n=0-15 (Device number=MIDI Channel)
FORMAT No. 01111110 7E Universal bulk dump
COUNT HIGH 0ccccccc ch data count = ch * 128 + cl
COUNT LOW 0ccccccc cl
01001100 4C 'L'
01001101 4D 'M'
00100000 20 ''
00100000 20 ''
00111000 38 '8'
01000011 43 'C'

```

```

00110001 31 '1'
00110010 32 '2'
DATA NAME  01001100 4C 'L'
00000000 00
0bbbbbbb bb b=0-3 (bank no.1-4)
BLOCK INFO. 0ttttttt tt total block number (minimum number
                is 0)
0bbbbbbb bb current block number (0-total block
                number)
DATA       0ddddd ds User defined layer data of block[bb]
:
:
0ddddd de
CHECK SUM  0eeeeeee ee ee= (Invert ('L'+...+de)+1)&0x7F
EOX      11110111 F7 End of exclusive

```

### 13.3.6 User defined layer bulk dump request format

The second and third bytes of the DATA NAME indicate the bank number.

```

STATUS      11110000 F0 System exclusive message
ID No.     01000011 43 Manufacture's ID number (YAMAHA)
SUB STATUS  0010nnnn 2n n=0-15 (Device number=MIDI Channel)
FORMAT No. 01111110 7E Universal bulk dump
01001100 4C 'L'
01001101 4D 'M'
00100000 20 ''
00100000 20 ''
00111000 38 '8'
01000011 43 'C'
00110001 31 '1'
00110010 32 '2'
DATA NAME  01001100 4C 'L'
00000000 00
0bbbbbbb bb b=0-3 (bank no.1-4)
EOX      11110111 F7 End of exclusive

```

### 13.3.7 User defined plug-in bulk dump format

The second and third bytes of the DATA NAME indicate the bank number.

Be aware that the state of the transmission destination will (in some cases) change if the same bank is being used.

```

STATUS      11110000 F0 System exclusive message
ID No.     01000011 43 Manufacture's ID number (YAMAHA)
SUB STATUS  0000nnnn 0n n=0-15 (Device number=MIDI Channel)
FORMAT No. 01111110 7E Universal bulk dump
COUNT HIGH 0ccccccc ch data count = ch * 128 + cl
COUNT LOW 0ccccccc cl
01001100 4C 'L'
01001101 4D 'M'
00100000 20 ''
00100000 20 ''
00111000 38 '8'
01000011 43 'C'
00110001 31 '1'
00110010 32 '2'
DATA NAME  01001001 49 'I'
00000000 00
0bbbbbbb bb b=0-7 (bank no.1-8)
BLOCK INFO. 0ttttttt tt total block number (minimum number
                is 0)
0bbbbbbb bb current block number (0-total block
                number)
DATA       0ddddd ds User define plug-in data of block[bb]
:
:
0ddddd de
CHECK SUM  0eeeeeee ee ee= (Invert ('L'+...+de)+1)&0x7F
EOX      11110111 F7 End of exclusive

```

**13.3.8 User defined plug-in bulk dump request format**

The second and third bytes of the DATA NAME indicate the bank number.

STATUS	11110000	F0	System exclusive message
ID No.	01000011	43	Manufacture's ID number (YAMAHA)
SUB STATUS	0010nnnn	2n	n=0-15 (Device number=MIDI Channel)
FORMAT No.	01111110	7E	Universal bulk dump
	01001100	4C	'L'
	01001101	4D	'M'
	00100000	20	''
	00100000	20	''
	00111000	38	'8'
	01000011	43	'C'
	00110001	31	'1'
	00110010	32	'2'
DATA NAME	01001001	49	'I'
	00000000	00	
	0bbbbbbb	bb	b=0-7 (bank no.1-8)
EOX	11110111	F7	End of exclusive

**13.3.9 User defined keys bulk dump format**

The second and third bytes of the DATA NAME indicate the bank number.

Be aware that the state of the transmission destination will (in some cases) change if the same bank is being used.

STATUS	11110000	F0	System exclusive message
ID No.	01000011	43	Manufacture's ID number (YAMAHA)
SUB STATUS	0000nnnn	0n	n=0-15 (Device number=MIDI Channel)
FORMAT No.	01111110	7E	Universal bulk dump
COUNT HIGH	0ccccccc	ch	data count = ch * 128 + cl
COUNT LOW	0ccccccc	cl	
	01001100	4C	'L'
	01001101	4D	'M'
	00100000	20	''
	00100000	20	''
	00111000	38	'8'
	01000011	43	'C'
	00110001	31	'1'
	00110010	32	'2'
DATA NAME	01010110	56	'V'
	00000000	00	
	0bbbbbbb	bb	b=0-7 (bank no.A-H)
BLOCK INFO.	0ttttttt	tt	total block number (minimum number is 0)
	0bbbbbbb	bb	current block number (0-total block number)
DATA	0ddddddd	ds	User defined key data of block[bb]
	:		
	:		
	0ddddddd	de	
CHECK SUM	0eeeeeee	ee	ee= (Invert ('L'+...+de)+1)&0x7F
EOX	11110111	F7	End of exclusive

**13.3.10 User defined keys bulk dump request format**

The second and third bytes of the DATA NAME indicate the bank number.

STATUS	11110000	F0	System exclusive message
ID No.	01000011	43	Manufacture's ID number (YAMAHA)
SUB STATUS	0010nnnn	2n	n=0-15 (Device number=MIDI Channel)
FORMAT No.	01111110	7E	Universal bulk dump
	01001100	4C	'L'
	01001101	4D	'M'
	00100000	20	''
	00100000	20	''
	00111000	38	'8'
	01000011	43	'C'
	00110001	31	'1'
	00110010	32	'2'
DATA NAME	01010110	56	'V'
	00000000	00	

	0bbbbbbb	bb	b=0-7 (bank no.A-H)
EOX	11110111	F7	End of exclusive

**13.3.11 User assignable layer bulk dump format**

The second and third bytes of the DATA NAME indicate the bank number.

Be aware that the state of the transmission destination will (in some cases) change if the same bank is being used.

STATUS	11110000	F0	System exclusive message
ID No.	01000011	43	Manufacture's ID number (YAMAHA)
SUB STATUS	0000nnnn	0n	n=0-15 (Device number=MIDI Channel)
FORMAT No.	01111110	7E	Universal bulk dump
COUNT HIGH	0ccccccc	ch	data count = ch * 128 + cl
COUNT LOW	0ccccccc	cl	
	01001100	4C	'L'
	01001101	4D	'M'
	00100000	20	''
	00100000	20	''
	00111000	38	'8'
	01000011	43	'C'
	00110001	31	'1'
	00110010	32	'2'
DATA NAME	01010101	55	'U'
	00000000	00	
	0bbbbbbb	bb	b=0-3 (bank no.1-4)
BLOCK INFO.	0ttttttt	tt	total block number (minimum number is 0)
	0bbbbbbb	bb	current block number (0-total block number)
DATA	0ddddddd	ds	User assignable layer data of block[bb]
	:		
	:		
	0ddddddd	de	
CHECK SUM	0eeeeeee	ee	ee= (Invert ('L'+...+de)+1)&0x7F
EOX	11110111	F7	End of exclusive

**13.3.12 User assignable layer bulk dump request format**

The second and third bytes of the DATA NAME indicate the bank number.

STATUS	11110000	F0	System exclusive message
ID No.	01000011	43	Manufacture's ID number (YAMAHA)
SUB STATUS	0010nnnn	2n	n=0-15 (Device number=MIDI Channel)
FORMAT No.	01111110	7E	Universal bulk dump
	01001100	4C	'L'
	01001101	4D	'M'
	00100000	20	''
	00100000	20	''
	00111000	38	'8'
	01000011	43	'C'
	00110001	31	'1'
	00110010	32	'2'
DATA NAME	01010101	55	'U'
	00000000	00	
	0bbbbbbb	bb	b=0-3 (bank no.1-4)
EOX	11110111	F7	End of exclusive

**13.3.13 Control change table bulk dump format**

STATUS	11110000	F0	System exclusive message
ID No.	01000011	43	Manufacture's ID number (YAMAHA)
SUB STATUS	0000nnnn	0n	n=0-15 (Device number=MIDI Channel)
FORMAT No.	01111110	7E	Universal bulk dump
COUNT HIGH	0ccccccc	ch	data count = ch * 128 + cl
COUNT LOW	0ccccccc	cl	
	01001100	4C	'L'
	01001101	4D	'M'
	00100000	20	''
	00100000	20	''
	00111000	38	'8'
	01000011	43	'C'

```

00110001 31 '1'
00110010 32 '2'
DATA NAME 01000011 43 'C'
00000010 02
00000000 00 No.256 = Current
BLOCK INFO. 0ttttttt tt total block number (minimum number
is 0)
0bbbbbbb bb current block number (0-total block
number)
DATA 0ddddd ds Control change table data of block[bb]
:
:
0ddddd de
CHECK SUM 0eeeeeee ee ee= (Invert ('L'+...+de)+1)&0x7F
EOX 11110111 F7 End of exclusive

```

### 13.3.14 Control change table bulk dump request format

```

STATUS 11110000 F0 System exclusive message
ID No. 01000011 43 Manufacture's ID number (YAMAHA)
SUB STATUS 0010nnnn 2n n=0-15 (Device number=MIDI Channel)
FORMAT No. 01111110 7E Universal bulk dump
01001100 4C 'L'
01001101 4D 'M'
00100000 20 ''
00100000 20 ''
00111000 38 '8'
01000011 43 'C'
00110001 31 '1'
00110010 32 '2'
DATA NAME 01000011 43 'C'
00000010 02
00000000 00 No.256 = Current
EOX 11110111 F7 End of exclusive

```

### 13.3.15 Program change table bulk dump format

```

STATUS 11110000 F0 System exclusive message
ID No. 01000011 43 Manufacture's ID number (YAMAHA)
SUB STATUS 0000nnnn 0n n=0-15 (Device number=MIDI Channel)
FORMAT No. 01111110 7E Universal bulk dump
COUNT HIGH 0ccccccc ch data count = ch * 128 + cl
COUNT LOW 0ccccccc cl
01001100 4C 'L'
01001101 4D 'M'
00100000 20 ''
00100000 20 ''
00111000 38 '8'
01000011 43 'C'
00110001 31 '1'
00110010 32 '2'
DATA NAME 01010000 50 'P'
00000010 02
00000000 00 No.256 = Current
BLOCK INFO. 0ttttttt tt total block number (minimum number
is 0)
0bbbbbbb bb current block number (0-total block
number)
DATA 0ddddd ds Program change table data of block[bb]
:
:
0ddddd de
CHECK SUM 0eeeeeee ee ee= (Invert ('L'+...+de)+1)&0x7F
EOX 11110111 F7 End of exclusive

```

### 13.3.16 Program change table bulk dump request format

```

STATUS 11110000 F0 System exclusive message
ID No. 01000011 43 Manufacture's ID number (YAMAHA)
SUB STATUS 0010nnnn 2n n=0-15 (Device number=MIDI Channel)
FORMAT No. 01111110 7E Universal bulk dump
01001100 4C 'L'
01001101 4D 'M'
00100000 20 ''
00100000 20 ''
00111000 38 '8'
01000011 43 'C'
00110001 31 '1'
00110010 32 '2'
DATA NAME 01010000 50 'P'
00000010 02
00000000 00 No.256 = Current
EOX 11110111 F7 End of exclusive

```

### 13.3.17 Equalizer library bulk dump format

The second and third bytes of the DATA NAME indicate the bank number.

0:Library no.1 - 199:Library no.200, 256:CH1 - 351:CH96, 384:BUS1 - 391:BUS8, 512:AUX1 - 523:AUX12, 640:MATRIX1L - 647:MATRIX4R, 768:STEREO L - 769:STEREO R, 8192:UNDO

256 and up are data for the corresponding channel of the edit buffer (excluding UNDO).

For reception by the DM2000, only the user area is valid. (40-199, 256-)

```

STATUS 11110000 F0 System exclusive message
ID No. 01000011 43 Manufacture's ID number (YAMAHA)
SUB STATUS 0000nnnn 0n n=0-15 (Device number=MIDI Channel)
FORMAT No. 01111110 7E Universal bulk dump
COUNT HIGH 0ccccccc ch data count = ch * 128 + cl
COUNT LOW 0ccccccc cl
01001100 4C 'L'
01001101 4D 'M'
00100000 20 ''
00100000 20 ''
00111000 38 '8'
01000011 43 'C'
00110001 31 '1'
00110010 32 '2'
DATA NAME 01010001 51 'Q'
0mmmmmmm mh 0-199 (EQ Library no.1-200),
0mmmmmmm ml 256- (Channel current data)
BLOCK INFO. 0ttttttt tt total block number (minimum number
is 0)
0bbbbbbb bb current block number (0-total block
number)
DATA 0ddddd ds EQ Library data of block[bb]
:
:
0ddddd de
CHECK SUM 0eeeeeee ee ee= (Invert ('L'+...+de)+1)&0x7F
EOX 11110111 F7 End of exclusive

```

### 13.3.18 Equalizer library bulk dump request format

The second and third bytes of the DATA NAME indicate the bank number. (See above)

```

STATUS 11110000 F0 System exclusive message
ID No. 01000011 43 Manufacture's ID number (YAMAHA)
SUB STATUS 0010nnnn 2n n=0-15 (Device number=MIDI Channel)
FORMAT No. 01111110 7E Universal bulk dump
01001100 4C 'L'
01001101 4D 'M'
00100000 20 ''
00100000 20 ''
00111000 38 '8'
01000011 43 'C'
00110001 31 '1'

```

```

00110010 32 '2'
DATA NAME 01010001 51 'Q'
           0mmmmmmm mh 0-199 (EQ Library no.1-200),
           0mmmmmmm ml 256- (Channel current data)
EOX       11110111 F7 End of exclusive
    
```

**13.3.19 Compressor library bulk dump format**

The second and third bytes of the DATA NAME indicate the library number.

0:Library no.1 - 127:Library no.128, 256:CH1 - 351:CH96, 384:BUS1 - 391:BUS8, 512:AUX1 - 523:AUX12, 640:MATRIX1L - 647:MATRIX4R, 768:STEREO L - 769:STEREO R, 8192:UNDO

256 and following are data for the corresponding channel of the edit buffer. For reception by the DM2000, only the user area is valid. (36-127, 256-)

```

STATUS     11110000 F0 System exclusive message
ID No.     01000011 43 Manufacture's ID number (YAMAHA)
SUB STATUS 0000nnnn 0n n=0-15 (Device number=MIDI Channel)
FORMAT No. 01111110 7E Universal bulk dump
COUNT HIGH 0ccccccc ch data count = ch * 128 + cl
COUNT LOW 0ccccccc cl
           01001100 4C 'L'
           01001101 4D 'M'
           00100000 20 ''
           00100000 20 ''
           00111000 38 '8'
           01000011 43 'C'
           00110001 31 '1'
           00110010 32 '2'
DATA NAME  01011001 59 'Y'
           0mmmmmmm mh 0-127 (COMP Library no.1-128),
           0mmmmmmm ml 256- (Channel current data)
BLOCK INFO. 0ttttttt tt total block number (minimum number
           is 0)
           0bbbbbbb bb current block number (0-total block
           number)
DATA        0ddddd ds COMP Library data of block[bb]
           :
           :
           0ddddd de
CHECK SUM  0eeeeeee ee ee= (Invert ('L'+...+de)+1)&0x7F
EOX       11110111 F7 End of exclusive
    
```

**13.3.20 Compressor library bulk dump request format**

The second and third bytes of the DATA NAME indicate the library number. (See above)

```

STATUS     11110000 F0 System exclusive message
ID No.     01000011 43 Manufacture's ID number (YAMAHA)
SUB STATUS 0010nnnn 2n n=0-15 (Device number=MIDI Channel)
FORMAT No. 01111110 7E Universal bulk dump
           01001100 4C 'L'
           01001101 4D 'M'
           00100000 20 ''
           00100000 20 ''
           00111000 38 '8'
           01000011 43 'C'
           00110001 31 '1'
           00110010 32 '2'
DATA NAME  01011001 59 'Y'
           0mmmmmmm mh 0-127 (COMP Library no.1-128),
           0mmmmmmm ml 256- (Channel current data)
EOX       11110111 F7 End of exclusive
    
```

**13.3.21 Gate library bulk dump format**

The second and third bytes of the DATA NAME indicate the library number.

0:Library no.1 - 127:Library no.128, 256:CH1 - 351:CH96, 8192:UNDO  
256 and following are data for the corresponding channel of the edit buffer. For reception by the DM2000, only the user area is valid. (4-127, 256-)

```

STATUS     11110000 F0 System exclusive message
ID No.     01000011 43 Manufacture's ID number (YAMAHA)
    
```

```

SUB STATUS 0000nnnn 0n n=0-15 (Device number=MIDI Channel)
FORMAT No. 01111110 7E Universal bulk dump
COUNT HIGH 0ccccccc ch data count = ch * 128 + cl
COUNT LOW 0ccccccc cl
           01001100 4C 'L'
           01001101 4D 'M'
           00100000 20 ''
           00100000 20 ''
           00111000 38 '8'
           01000011 43 'C'
           00110001 31 '1'
           00110010 32 '2'
DATA NAME  01000111 47 'G'
           0mmmmmmm mh 0-127 (GATE Library no.1-128),
           0mmmmmmm ml 256-351 (Channel current data)
BLOCK INFO. 0ttttttt tt total block number (minimum number
           is 0)
           0bbbbbbb bb current block number (0-total block
           number)
DATA        0ddddd ds GATE Library data of block[bb]
           :
           :
           0ddddd de
CHECK SUM  0eeeeeee ee ee= (Invert ('L'+...+de)+1)&0x7F
EOX       11110111 F7 End of exclusive
    
```

**13.3.22 Gate library bulk dump request format**

The second and third bytes of the DATA NAME indicate the library number. (See above)

```

STATUS     11110000 F0 System exclusive message
ID No.     01000011 43 Manufacture's ID number (YAMAHA)
SUB STATUS 0010nnnn 2n n=0-15 (Device number=MIDI Channel)
FORMAT No. 01111110 7E Universal bulk dump
           01001100 4C 'L'
           01001101 4D 'M'
           00100000 20 ''
           00100000 20 ''
           00111000 38 '8'
           01000011 43 'C'
           00110001 31 '1'
           00110010 32 '2'
DATA NAME  01000111 47 'G'
           0mmmmmmm mh 0-127 (GATE Library no.1-128),
           0mmmmmmm ml 256-351 (Channel current data)
EOX       11110111 F7 End of exclusive
    
```

**13.3.23 Effect library bulk dump format**

The second and third bytes of the DATA NAME indicate the library number.

0:Library no.1 - 127:Library no.128, 256:Effect1 - 263:Effect8, 8192:UNDO  
256-263 are the data for the corresponding area of the edit buffer. For reception by the DM2000, only the user area is valid. (61-127, 256-263)

```

STATUS     11110000 F0 System exclusive message
ID No.     01000011 43 Manufacture's ID number (YAMAHA)
SUB STATUS 0000nnnn 0n n=0-15 (Device number=MIDI Channel)
FORMAT No. 01111110 7E Universal bulk dump
COUNT HIGH 0ccccccc ch data count = ch * 128 + cl
COUNT LOW 0ccccccc cl
           01001100 4C 'L'
           01001101 4D 'M'
           00100000 20 ''
           00100000 20 ''
           00111000 38 '8'
           01000011 43 'C'
           00110001 31 '1'
           00110010 32 '2'
DATA NAME  01000101 45 'E'
           0mmmmmmm mh 0-127 (Effect Library no.1-128),
           0mmmmmmm ml 256-259 (Effect1-8 current)
    
```

```

BLOCK INFO. 0ttttttt tt total block number (minimum number
                0bbbbbbb bb current block number (0-total block
                :
                :
                0ddddd de Effect Library data of block[bb]
CHECK SUM 0eeeeeee ee ee= (Invert ('L'+...+de)+1)&0x7F
EOX 11110111 F7 End of exclusive
    
```

**13.3.24 Effect library bulk dump request format**

The second and third bytes of the DATA NAME indicate the library number. (See above)

```

STATUS 11110000 F0 System exclusive message
ID No. 01000011 43 Manufacture's ID number (YAMAHA)
SUB STATUS 0010nnnn 2n n=0-15 (Device number=MIDI Channel)
FORMAT No. 01111110 7E Universal bulk dump
                01001100 4C 'L'
                01001101 4D 'M'
                00100000 20 ''
                00100000 20 ''
                00111000 38 '8'
                01000011 43 'C'
                00110001 31 '1'
                00110010 32 '2'
DATA NAME 01000101 45 'E'
                0mmmmmm mh 0-127 (Effect Library no.1-128),
                0mmmmmm ml 256-259 (Effect1-8 current)
EOX 11110111 F7 End of exclusive
    
```

**13.3.25 GEQ library bulk dump format**

The second and third bytes of the DATA NAME indicate the library number.

0:Library no.0 - 128:Library no.128, 256:GEQ1 - 261:GEQ6, 8192:UNDO  
 256-261are the data for the corresponding area of the edit buffer.  
 For reception by the DM2000, only the user area is valid. (1-128, 256-261)

```

STATUS 11110000 F0 System exclusive message
ID No. 01000011 43 Manufacture's ID number (YAMAHA)
SUB STATUS 0000nnnn 0n n=0-15 (Device number=MIDI Channel)
FORMAT No. 01111110 7E Universal bulk dump
COUNT HIGH 0ccccccc ch data count = ch * 128 + cl
COUNT LOW 0ccccccc cl
                01001100 4C 'L'
                01001101 4D 'M'
                00100000 20 ''
                00100000 20 ''
                00111000 38 '8'
                01000011 43 'C'
                00110001 31 '1'
                00110010 32 '2'
DATA NAME 01000110 46 'F'
                0mmmmmm mh 0-128 (GEQ Library no.0-128),
                0mmmmmm ml 256-261 (GEQ1-6 current)
BLOCK INFO. 0ttttttt tt total block number (minimum number
                0bbbbbbb bb current block number (0-total block
                :
                :
                0ddddd de GEQ Library data of block[bb]
CHECK SUM 0eeeeeee ee ee= (Invert ('L'+...+de)+1)&0x7F
EOX 11110111 F7 End of exclusive
    
```

**13.3.26 GEQ library bulk dump request format**

The second and third bytes of the DATA NAME indicate the library number. (See above)

```

STATUS 11110000 F0 System exclusive message
ID No. 01000011 43 Manufacture's ID number (YAMAHA)
    
```

```

SUB STATUS 0010nnnn 2n n=0-15 (Device number=MIDI Channel)
FORMAT No. 01111110 7E Universal bulk dump
                01001100 4C 'L'
                01001101 4D 'M'
                00100000 20 ''
                00100000 20 ''
                00111000 38 '8'
                01000011 43 'C'
                00110001 31 '1'
                00110010 32 '2'
DATA NAME 01000110 46 'F'
                0mmmmmm mh 0-128 (GEQ Library no.0-128),
                0mmmmmm ml 256-261 (GEQ1-6 current)
EOX 11110111 F7 End of exclusive
    
```

**13.3.27 Channel library bulk dump format**

The second and third bytes of the DATA NAME indicate the library number.

0:Library no.0 - 128:Library no.128, 256:CH1 - 351:CH96, 384:BUS1 - 391:BUS8, 512:AUX1 - 523:AUX12, 640:MATRIX1L - 647:MATRIX4R, 768:STEREO L - 769:STEREO R, 8192:UNDO

256 and following are data for the corresponding channel of the edit buffer. For reception by the DM2000, only the user area is valid. (2-128,256-)

```

STATUS 11110000 F0 System exclusive message
ID No. 01000011 43 Manufacture's ID number (YAMAHA)
SUB STATUS 0000nnnn 0n n=0-15 (Device number=MIDI Channel)
FORMAT No. 01111110 7E Universal bulk dump
COUNT HIGH 0ccccccc ch data count = ch * 128 + cl
COUNT LOW 0ccccccc cl
                01001100 4C 'L'
                01001101 4D 'M'
                00100000 20 ''
                00100000 20 ''
                00111000 38 '8'
                01000011 43 'C'
                00110001 31 '1'
                00110010 32 '2'
DATA NAME 01001000 48 'H'
                0mmmmmm mh 0-128 (Channel Library no.0-128),
                0mmmmmm ml 256- (Current data)
BLOCK INFO. 0ttttttt tt total block number (minimum number
                0bbbbbbb bb current block number (0-total block
                :
                :
                0ddddd de Channel Library data of block[bb]
CHECK SUM 0eeeeeee ee ee= (Invert ('L'+...+de)+1)&0x7F
EOX 11110111 F7 End of exclusive
    
```

**13.3.28 Channel library bulk dump request format**

The second and third bytes of the DATA NAME indicate the library number. (See above)

```

STATUS 11110000 F0 System exclusive message
ID No. 01000011 43 Manufacture's ID number (YAMAHA)
SUB STATUS 0010nnnn 2n n=0-15 (Device number=MIDI Channel)
FORMAT No. 01111110 7E Universal bulk dump
                01001100 4C 'L'
                01001101 4D 'M'
                00100000 20 ''
                00100000 20 ''
                00111000 38 '8'
                01000011 43 'C'
                00110001 31 '1'
                00110010 32 '2'
DATA NAME 01001000 48 'H'
                0mmmmmm mh 0-128 (Channel Library no.0-128),
                0mmmmmm ml 256- (Current data)
EOX 11110111 F7 End of exclusive
    
```



**13.3.29 Input patch library bulk dump format**

The second and third bytes of the DATA NAME indicate the library number.

0:Library no.0 - 32:Library no.32, 256:Current data, 8192:UNDO  
For reception by the DM2000, only the user area is valid. (1-32,256)

STATUS	11110000	F0	System exclusive message
ID No.	01000011	43	Manufacture's ID number (YAMAHA)
SUB STATUS	0000nnnn	0n	n=0-15 (Device number=MIDI Channel)
FORMAT No.	01111110	7E	Universal bulk dump
COUNT HIGH	0ccccccc	ch	data count = ch * 128 + cl
COUNT LOW	0ccccccc	cl	
	01001100	4C	'L'
	01001101	4D	'M'
	00100000	20	''
	00100000	20	''
	00111000	38	'8'
	01000011	43	'C'
	00110001	31	'1'
	00110010	32	'2'
DATA NAME	01010010	52	'R'
	0mmmmmmm	mh	0-32 (Input patch Library no.0-32),
	0mmmmmmm	m1	256 (Current data)
BLOCK INFO.	0ttttttt	tt	total block number (minimum number is 0)
	0bbbbbbb	bb	current block number (0-total block number)
DATA	0ddddddd	ds	Input patch Library data of block[bb]
	:		
	:		
	0ddddddd	de	
CHECK SUM	0eeeeeee	ee	ee= (Invert ('L'+...+de)+1)&0x7F
EOX	11110111	F7	End of exclusive

**13.3.30 Input patch library bulk dump request format**

The second and third bytes of the DATA NAME indicate the library number. (See above)

STATUS	11110000	F0	System exclusive message
ID No.	01000011	43	Manufacture's ID number (YAMAHA)
SUB STATUS	0010nnnn	2n	n=0-15 (Device number=MIDI Channel)
FORMAT No.	01111110	7E	Universal bulk dump
	01001100	4C	'L'
	01001101	4D	'M'
	00100000	20	''
	00100000	20	''
	00111000	38	'8'
	01000011	43	'C'
	00110001	31	'1'
	00110010	32	'2'
DATA NAME	01010010	52	'R'
	0mmmmmmm	mh	0-32 (Input patch Library no.0-32),
	0mmmmmmm	m1	256 (Current data)
EOX	11110111	F7	End of exclusive

**13.3.31 Output patch library bulk dump format**

The second and third bytes of the DATA NAME indicate the library number.

0:Library no.0 - 32:Library no.32, 256:Current data, 8192:UNDO  
For reception by the DM2000, only the user area is valid. (1-32,256)

STATUS	11110000	F0	System exclusive message
ID No.	01000011	43	Manufacture's ID number (YAMAHA)
SUB STATUS	0000nnnn	0n	n=0-15 (Device number=MIDI Channel)
FORMAT No.	01111110	7E	Universal bulk dump
COUNT HIGH	0ccccccc	ch	data count = ch * 128 + cl
COUNT LOW	0ccccccc	cl	
	01001100	4C	'L'
	01001101	4D	'M'
	00100000	20	''
	00100000	20	''
	00111000	38	'8'
	01000011	43	'C'

	00110001	31	'1'
	00110010	32	'2'
DATA NAME	01001111	4F	'O'
	0mmmmmmm	mh	0-32 (Output patch Library no.0-32),
	0mmmmmmm	m1	256 (Current data)
BLOCK INFO.	0ttttttt	tt	total block number (minimum number is 0)
	0bbbbbbb	bb	current block number (0-total block number)
DATA	0ddddddd	ds	Output patch Library data of block[bb]
	:		
	:		
	0ddddddd	de	
CHECK SUM	0eeeeeee	ee	ee= (Invert ('L'+...+de)+1)&0x7F
EOX	11110111	F7	End of exclusive

**13.3.32 Output patch library bulk dump request format**

The second and third bytes of the DATA NAME indicate the library number. (See above)

STATUS	11110000	F0	System exclusive message
ID No.	01000011	43	Manufacture's ID number (YAMAHA)
SUB STATUS	0010nnnn	2n	n=0-15 (Device number=MIDI Channel)
FORMAT No.	01111110	7E	Universal bulk dump
	01001100	4C	'L'
	01001101	4D	'M'
	00100000	20	''
	00100000	20	''
	00111000	38	'8'
	01000011	43	'C'
	00110001	31	'1'
	00110010	32	'2'
DATA NAME	01001111	4F	'O'
	0mmmmmmm	mh	0-32 (Output patch Library no.0-32),
	0mmmmmmm	m1	256 (Current data)
EOX	11110111	F7	End of exclusive

**13.3.33 Bus to stereo library bulk dump format**

The second and third bytes of the DATA NAME indicate the library number.

0:Library no.0 - 32:Library no.32, 256:Current data, 8192:UNDO  
For reception by the DM2000, only the user area is valid. (1-32,256)

STATUS	11110000	F0	System exclusive message
ID No.	01000011	43	Manufacture's ID number (YAMAHA)
SUB STATUS	0000nnnn	0n	n=0-15 (Device number=MIDI Channel)
FORMAT No.	01111110	7E	Universal bulk dump
COUNT HIGH	0ccccccc	ch	data count = ch * 128 + cl
COUNT LOW	0ccccccc	cl	
	01001100	4C	'L'
	01001101	4D	'M'
	00100000	20	''
	00100000	20	''
	00111000	38	'8'
	01000011	43	'C'
	00110001	31	'1'
	00110010	32	'2'
DATA NAME	01001010	4A	'J'
	0mmmmmmm	mh	0-32 (Bus to stereo Library no.0-32),
	0mmmmmmm	m1	256 (Current data)
BLOCK INFO.	0ttttttt	tt	total block number (minimum number is 0)
	0bbbbbbb	bb	current block number (0-total block number)
DATA	0ddddddd	ds	Bus to stereo Library data of block[bb]
	:		
	:		
	0ddddddd	de	
CHECK SUM	0eeeeeee	ee	ee= (Invert ('L'+...+de)+1)&0x7F
EOX	11110111	F7	End of exclusive

### 13.3.34 Bus to stereo library bulk dump request format

The second and third bytes of the DATA NAME indicate the library number. (See above)

```

STATUS      11110000 F0 System exclusive message
ID No.      01000011 43 Manufacture's ID number (YAMAHA)
SUB STATUS  0010nnnn 2n n=0-15 (Device number=MIDI Channel)
FORMAT No.  01111110 7E Universal bulk dump
             01001100 4C 'L'
             01001101 4D 'M'
             00100000 20 ''
             00100000 20 ''
             00111000 38 '8'
             01000011 43 'C'
             00110001 31 '1'
             00110010 32 '2'
DATA NAME   01001010 4A 'J'
             0mmmmmmmm mh 0-32 (Bus to stereo Library no.0-32),
             0mmmmmmmm m1 256 (Current data)
EOX         11110111 F7 End of exclusive

```

### 13.3.35 Surround monitor library bulk dump format

The second and third bytes of the DATA NAME indicate the library number.

0:Library no.0 - 32:Library no.32, 256:Current data, 8192:UNDO  
For reception by the DM2000, only the user area is valid. (1-32,256)

```

STATUS      11110000 F0 System exclusive message
ID No.      01000011 43 Manufacture's ID number (YAMAHA)
SUB STATUS  0000nnnn 0n n=0-15 (Device number=MIDI Channel)
FORMAT No.  01111110 7E Universal bulk dump
COUNT HIGH 0ccccccc ch data count = ch * 128 + cl
COUNT LOW  0ccccccc cl
             01001100 4C 'L'
             01001101 4D 'M'
             00100000 20 ''
             00100000 20 ''
             00111000 38 '8'
             01000011 43 'C'
             00110001 31 '1'
             00110010 32 '2'
DATA NAME   01001011 4B 'K'
             0mmmmmmmm mh 0-32 (Surround Monitor Library
             no.0-32),
             0mmmmmmmm m1 256 (Current data)
BLOCK INFO. 0ttttttt tt total block number (minimum number
             is 0)
             0bbbbbbb bb current block number (0-total block
             number)
DATA        0ddddddd ds Surround Monitor Library data of
             block[bb]
             :
             :
             0ddddddd de
CHECK SUM   0eeeeeee ee ee= (Invert ('L'+...+de)+1)&0x7F
EOX         11110111 F7 End of exclusive

```

### 13.3.36 Surround monitor library bulk dump request format

The second and third bytes of the DATA NAME indicate the library number. (See above)

```

STATUS      11110000 F0 System exclusive message
ID No.      01000011 43 Manufacture's ID number (YAMAHA)
SUB STATUS  0010nnnn 2n n=0-15 (Device number=MIDI Channel)
FORMAT No.  01111110 7E Universal bulk dump
             01001100 4C 'L'
             01001101 4D 'M'
             00100000 20 ''
             00100000 20 ''
             00111000 38 '8'
             01000011 43 'C'
             00110001 31 '1'

```

```

             00110010 32 '2'
DATA NAME   01001011 4B 'K'
             0mmmmmmmm mh 0-32 (Surround Monitor Library
             no.0-32),
             0mmmmmmmm m1 256 (Current data)
EOX         11110111 F7 End of exclusive

```

### 13.3.37 Automix bulk dump format (compressed data)

The second byte of the DATA NAME indicates the library number.  
0:Library no.1 - 15:Library no.16, 256:Current automix data

```

STATUS      11110000 F0 System exclusive message
ID No.      01000011 43 Manufacture's ID number (YAMAHA)
SUB STATUS  0000nnnn 0n n=0-15 (Device number=MIDI Channel)
FORMAT No.  01111110 7E Universal bulk dump
COUNT HIGH 0ccccccc ch data count = ch * 128 + cl
COUNT LOW  0ccccccc cl
             01001100 4C 'L'
             01001101 4D 'M'
             00100000 20 ''
             00100000 20 ''
             00111000 38 '8'
             01000011 43 'C'
             00110001 31 '1'
             00110010 32 '2'
DATA NAME   01100001 61 'a'
             0mmmmmmmm mh 0-15 (Automix no.1-16), 256 (Current
             data)
             0mmmmmmmm m1 BLOCK INFO.
             0bbbbbbb bh current block number (0-total block
             number)
             0bbbbbbb bl
             0ttttttt th total block number (minimum number
             is 0)
             0ttttttt tl
DATA        0ddddddd ds Automix memory data of block[bb]
             :
             :
             0ddddddd de
CHECK SUM   0eeeeeee ee ee= (Invert ('L'+...+de)+1)&0x7F
EOX         11110111 F7 End of exclusive

```

### 13.3.38 Automix bulk dump request format (compressed data)

The second and third bytes of the DATA NAME indicate the library number. (See above)

```

STATUS      11110000 F0 System exclusive message
ID No.      01000011 43 Manufacture's ID number (YAMAHA)
SUB STATUS  0010nnnn 2n n=0-15 (Device number=MIDI Channel)
FORMAT No.  01111110 7E Universal bulk dump
             01001100 4C 'L'
             01001101 4D 'M'
             00100000 20 ''
             00100000 20 ''
             00111000 38 '8'
             01000011 43 'C'
             00110001 31 '1'
             00110010 32 '2'
DATA NAME   01100001 61 'a'
             0mmmmmmmm mh 0-15 (Automix no.1-16), 256 (Current
             data)
             0mmmmmmmm m1
EOX         11110111 F7 End of exclusive

```

### 13.3.39 Plug-in effect card bulk dump format

The second byte of the DATA NAME indicates the slot number.  
0:SLOT 4 - 2:SLOT 6

The data is not received if the Developer ID and Product ID are different than the card that is installed in the slot.

The data is not transmitted if a valid plug-in effect card is not installed.

```

STATUS      11110000 F0 System exclusive message

```

ID No.	01000011	43	Manufacture's ID number (YAMAHA)
SUB STATUS	0000nnnn	0n	n=0-15 (Device number=MIDI Channel)
FORMAT No.	01111110	7E	Universal bulk dump
COUNT HIGH	0ccccccc	ch	data count = ch * 128 + cl
COUNT LOW	0ccccccc	cl	
	01001100	4C	'L'
	01001101	4D	'M'
	00100000	20	''
	00100000	20	''
	00111000	38	'8'
	01000011	43	'C'
	00110001	31	'1'
	00110010	32	'2'
DATA NAME	01001110	4E	'N'
	0mmmmmmm	mh	m=0-2 (SLOT 4-6)
	0mmmmmmm	m1	BLOCK INFO.
	0bbbbbbb	bh	current block number (0-total block number)
	0bbbbbbb	b1	
	0ttttttt	th	total block number (minimum number is 0)
	0ttttttt	t1	
	0000iiii	0i	Developer id (High)
	0000iiii	0i	Developer id (Low)
	0000jjjj	0j	Product id (High)
	0000jjjj	0j	Product id (Low)
DATA	0ddddd	ds	Plug-in Effect card memory data of block[bb]
	:		
	:		
	0ddddd	de	
CHECK SUM	0eeeeeee	ee	ee= (Invert ('L'+...+de)+1)&0x7F
EOX	11110111	F7	End of exclusive

**13.3.40 Plug-in effect card bulk dump request format**

The second and third bytes of the DATA NAME indicate the slot number. (See above)

STATUS	11110000	F0	System exclusive message
ID No.	01000011	43	Manufacture's ID number (YAMAHA)
SUB STATUS	0010nnnn	2n	n=0-15 (Device number=MIDI Channel)
FORMAT No.	01111110	7E	Universal bulk dump
	01001100	4C	'L'
	01001101	4D	'M'
	00100000	20	''
	00100000	20	''
	00111000	38	'8'
	01000011	43	'C'
	00110001	31	'1'
	00110010	32	'2'
DATA NAME	01001110	4E	'N'
	0mmmmmmm	mh	m=0-2 (SLOT 4-6)
	0mmmmmmm	m1	
EOX	11110111	F7	End of exclusive

**13.4 PARAMETER CHANGE**

**Reception**

If [Parameter change ECHO] is ON, these messages are echoed. If [Parameter change RX] is ON and the [Rx CH] matches the Device Number included in the SUB STATUS, these messages are received. A specific parameter is controlled when a Parameter Change is received. When a Parameter Request is received, the current value of the specified parameter will be transmitted as a Parameter Change with the Device Number set to [Rx CH].

**Transmission**

If [Parameter change TX] is ON and you operate a parameter for which Control Change transmission is not enabled, a parameter change will be transmitted with [Tx CH] as the Device Number. As a response to a Parameter Request, a parameter change will be transmitted with [Rx CH] as the Device Number.

**13.4.1 Parameter change basic format (DM2000-specific)**

STATUS	11110000	F0	System exclusive message
ID No.	01000011	43	Manufacture's ID number (YAMAHA)
SUB STATUS	0001nnnn	1n	n=0-15 (Device number=MIDI Channel)
GROUP ID	00111110	3E	MODEL ID (digital mixer)
MODEL ID	00000110	06	DM2000
ADDRESS	0ttttttt	tt	Data type
	0eeeeeee	ee	Element no. (If 'ee' is 0, 'ee' is expanded to two bytes)
	0ppppppp	pp	Parameter no.
	0ccccccc	cc	Channel no.
DATA *)	0ddddd	dd	data
	:		
	:		
EOX	11110111	F7	End of exclusive

\*) For parameters with a data size of 2 or more, data for that size will be transmitted.

**13.4.2 Parameter Change basic format (Universal format)**

STATUS	11110000	F0	System exclusive message
ID No.	01000011	43	Manufacture's ID number (YAMAHA)
SUB STATUS	0001nnnn	1n	n=0-15 (Device number=MIDI Channel)
GROUP ID	00111110	3E	MODEL ID (digital mixer)
MODEL ID	01111111	7F	Universal
ADDRESS	0ttttttt	tt	Data type
	0eeeeeee	ee	Element no. (If 'ee' is 0, 'ee' is expanded to two bytes)
	0ppppppp	pp	Parameter no.
	0ccccccc	cc	Channel no.
DATA *)	0ddddd	dd	data
	:		
	:		
EOX	11110111	F7	End of exclusive

\*) For parameters with a data size of 2 or more, data for that size will be transmitted.

**13.4.3 Parameter request basic format (DM2000-specific)**

STATUS	11110000	F0	System exclusive message
ID No.	01000011	43	Manufacture's ID number (YAMAHA)
SUB STATUS	0011nnnn	3n	n=0-15 (Device number=MIDI Channel)
GROUP ID	00111110	3E	MODEL ID (digital mixer)
MODEL ID	00000110	06	DM2000
ADDRESS	0ttttttt	tt	Data type
	0eeeeeee	ee	Element no. (If 'ee' is 0, 'ee' is expanded to two bytes)
	0ppppppp	pp	Parameter no.
	0ccccccc	cc	Channel no.
EOX	11110111	F7	End of exclusive

**13.4.4 Parameter request basic format (Universal format)**

STATUS	11110000	F0	System exclusive message
ID No.	01000011	43	Manufacture's ID number (YAMAHA)
SUB STATUS	0011nnnn	3n	n=0-15 (Device number=MIDI Channel)
GROUP ID	00111110	3E	MODEL ID (digital mixer)
MODEL ID	01111111	7F	Universal
ADDRESS	0ttttttt	tt	Data type
	0eeeeeee	ee	Element no. (If 'ee' is 0, 'ee' is expanded to two bytes)
	0ppppppp	pp	Parameter no.
	0ccccccc	cc	Channel no.
EOX	11110111	F7	End of exclusive

**13.4.5 Parameter Address**

Consult your dealer for parameter address details.

**13.4.6 Parameter change (Edit buffer)****Reception**

If [Parameter change RX] is ON and the [Rx CH] matches the Device Number included in the SUB STATUS, these messages are received. If [Parameter change ECHO] is ON, these messages are echoed.

When this is received, the specified parameter will be controlled.

**Transmission**

If [Parameter change TX] is ON and a parameter that is not assigned in the [Control Assign Table] is changed, the Parameter Change messages are transmitted on [Tx CH] device number channel.

```

STATUS      11110000 F0 System exclusive message
ID No.      01000011 43 Manufacture's ID number (YAMAHA)
SUB STATUS  0001nnnn 1n n=0-15 (Device number=MIDI Channel)
GROUP ID    00111110 3E MODEL ID (digital mixer)
MODEL ID    01111111 7F Universal
ADDRESS     00000001 01 Edit Buffer
             0eeeeeee ee Element no. (If 'ee' is 0, 'ee' is expanded
             0pppppppp pp Parameter no.
             0ccccccc cc Channel no.
DATA        0ddddddd dd data
:
:
EOX         11110111 F7 End of exclusive

```

**13.4.7 Parameter request (Edit buffer)****Reception**

If [Parameter change RX] is ON and the [Rx CH] matches the Device Number included in the SUB STATUS, these messages are received. If [Parameter change ECHO] is ON, these messages are echoed.

When this is received, the value of the specified parameter will be transmitted as a Parameter change.

```

STATUS      11110000 F0 System exclusive message
ID No.      01000011 43 Manufacture's ID number (YAMAHA)
SUB STATUS  0011nnnn 3n n=0-15 (Device number=MIDI Channel)
GROUP ID    00111110 3E MODEL ID (digital mixer)
MODEL ID    01111111 7F Universal
ADDRESS     00000001 01 Edit Buffer
             0eeeeeee ee Element no. (If 'ee' is 0, 'ee' is expanded
             0pppppppp pp Parameter no.
             0ccccccc cc Channel no.
EOX         11110111 F7 End of exclusive

```

**13.4.8 Parameter change (Patch data)****Reception**

If [Parameter change RX] is ON and the [Rx CH] matches the Device Number included in the SUB STATUS, these messages are received. If [Parameter change ECHO] is ON, these messages are echoed.

When this is received, the specified parameter will be controlled.

```

STATUS      11110000 F0 System exclusive message
ID No.      01000011 43 Manufacture's ID number (YAMAHA)
SUB STATUS  0001nnnn 1n n=0-15 (Device number=MIDI Channel)
GROUP ID    00111110 3E MODEL ID (digital mixer)
MODEL ID    00000110 06 DM2000
ADDRESS     00000010 02 Patch data
             0eeeeeee ee Element no. (If 'ee' is 0, 'ee' is expanded
             0pppppppp pp Parameter no.
             0ccccccc cc Channel no.
DATA        0ddddddd dd data
:
:
EOX         11110111 F7 End of exclusive

```

**13.4.9 Parameter request (Patch data)****Reception**

If [Parameter change RX] is ON and the [Rx CH] matches the Device Number included in the SUB STATUS, these messages are received. If [Parameter change ECHO] is ON, these messages are echoed.

When this is received, the value of the specified parameter will be transmitted as a Parameter change.

```

STATUS      11110000 F0 System exclusive message
ID No.      01000011 43 Manufacture's ID number (YAMAHA)
SUB STATUS  0011nnnn 3n n=0-15 (Device number=MIDI Channel)
GROUP ID    00111110 3E MODEL ID (digital mixer)
MODEL ID    00000110 06 DM2000
ADDRESS     00000010 02 Patch data
             0eeeeeee ee Element no. (If 'ee' is 0, 'ee' is expanded
             0pppppppp pp Parameter no.
             0ccccccc cc Channel no.
EOX         11110111 F7 End of exclusive

```

**13.4.10 Parameter change (Setup memory)****Reception**

If [Parameter change RX] is ON and the [Rx CH] matches the Device Number included in the SUB STATUS, these messages are received. If [Parameter change ECHO] is ON, these messages are echoed.

When this is received, the specified parameter will be controlled.

```

STATUS      11110000 F0 System exclusive message
ID No.      01000011 43 Manufacture's ID number (YAMAHA)
SUB STATUS  0001nnnn 1n n=0-15 (Device number=MIDI Channel)
GROUP ID    00111110 3E MODEL ID (digital mixer)
MODEL ID    00000110 06 DM2000
ADDRESS     00000011 03 Setup data
             0eeeeeee ee Element no. (If 'ee' is 0, 'ee' is expanded
             0pppppppp pp Parameter no.
             0ccccccc cc Channel no.
DATA        0ddddddd dd data
:
:
EOX         11110111 F7 End of exclusive

```

**13.4.11 Parameter request (Setup memory)****Reception**

If [Parameter change RX] is ON and the [Rx CH] matches the Device Number included in the SUB STATUS, these messages are received. If [Parameter change ECHO] is ON, these messages are echoed.

When this is received, the value of the specified parameter will be transmitted as a Parameter change.

```

STATUS      11110000 F0 System exclusive message
ID No.      01000011 43 Manufacture's ID number (YAMAHA)
SUB STATUS  0011nnnn 3n n=0-15 (Device number=MIDI Channel)
GROUP ID    00111110 3E MODEL ID (digital mixer)
MODEL ID    00000110 06 DM2000
ADDRESS     00000011 03 Setup data
             0eeeeeee ee Element no. (If 'ee' is 0, 'ee' is expanded
             0pppppppp pp Parameter no.
             0ccccccc cc Channel no.
EOX         11110111 F7 End of exclusive

```

**13.4.12 Parameter change (Backup memory)****Reception**

If [Parameter change RX] is ON and the [Rx CH] matches the Device Number included in the SUB STATUS, these messages are received. If [Parameter change ECHO] is ON, these messages are echoed.

When this is received, the specified parameter will be controlled.

```

STATUS      11110000 F0 System exclusive message
ID No.      01000011 43 Manufacture's ID number (YAMAHA)
SUB STATUS  0001nnnn 1n n=0-15 (Device number=MIDI Channel)
GROUP ID    00111110 3E MODEL ID (digital mixer)
MODEL ID    00000110 06 DM2000
ADDRESS     00000100 04 Backup data

```

```

00000000 ee Element no. (If 'ee' is 0, 'ee' is expanded
to two bytes)
0pppppppp pp Parameter no.
0ccccccc cc Channel no.
DATA 0ddddd dd data
:
:
EOX 11110111 F7 End of exclusive
    
```

**13.4.13 Parameter request (Backup memory)**

**Reception**

If [Parameter change RX] is ON and the [Rx CH] matches the Device Number included in the SUB STATUS, these messages are received. If [Parameter change ECHO] is ON, these messages are echoed. When this is received, the value of the specified parameter will be transmitted as a Parameter change.

```

STATUS 11110000 F0 System exclusive message
ID No. 01000011 43 Manufacture's ID number (YAMAHA)
SUB STATUS 0011nnnn 3n n=0-15 (Device number=MIDI Channel)
GROUP ID 00111110 3E MODEL ID (digital mixer)
MODEL ID 00000110 06 DM2000
ADDRESS 00000100 04 Backup data
00000000 ee Element no. (If 'ee' is 0, 'ee' is expanded
to two bytes)
0pppppppp pp Parameter no.
0ccccccc cc Channel no.
EOX 11110111 F7 End of exclusive
    
```

**13.4.14 Parameter change (Function call Library: store / recall)**

**Reception**

If [Parameter change RX] is ON and the [Rx CH] matches the Device Number included in the SUB STATUS, these messages are received. If [Parameter change ECHO] is ON, these messages are echoed. When this is received, the specified memory/library will be stored/recalled.

**Transmission**

If [Parameter change ECHO] is ON, this message will be retransmitted without change.

```

STATUS 11110000 F0 System exclusive message
ID No. 01000011 43 Manufacture's ID number (YAMAHA)
SUB STATUS 0001nnnn 1n n=0-15 (Device number=MIDI Channel)
GROUP ID 00111110 3E MODEL ID (digital mixer)
MODEL ID 01111111 7F Universal
ADDRESS 00010000 10 Function call
00ffffff ff function
0mmmmmmm mh number High
0mmmmmmm ml number Low
DATA 0ccccccc ch channel High
0ccccccc cl channel Low
EOX 11110111 F7 End of exclusive
    
```

function		number	channel*1)	rx/tx
SCENE RECALL	0x00	0-99, 8192	256	rx/tx*2)
EQ LIB RECALL	0x01	1-200, 8192	0-513	rx/tx
GATE LIB RECALL	0x02	1-128, 8192	0-95	rx/tx
COMP LIB RECALL	0x03	1-128, 8192	0-513	rx/tx
EFF LIB RECALL	0x04	1-128, 8192	0-7	rx/tx
GEQ LIB RECALL	0x05	0-128, 8192	0-5	rx/tx
CHANNEL LIB RECALL	0x06	0-128, 8192	0-513	rx/tx
INPATCH LIB RECALL	0x07	0-32, 8192	256	rx/tx
OUTPATCH LIB RECALL	0x08	0-32, 8192	256	rx/tx
Bus to Stereo LIB RECALL	0x09	0-32, 8192	256	rx/tx
Surround Monitor LIB RECALL	0x0A	0-32, 8192	256	rx/tx
AUTOMIX LIB RECALL	0x0B	1-16	256	rx/tx
SCENE STORE	0x20	1-99	256, 16383	rx/tx
EQ LIB STORE	0x21	41-200	0-513, 16383	rx/tx
GATE LIB STORE	0x22	5-128	0-95, 16383	rx/tx
COMP LIB STORE	0x23	37-128	0-513, 16383	rx/tx
EFF LIB STORE	0x24	xx*3)-128	0-7, 16383	rx/tx
GEQ LIB STORE	0x25	1-128	0-5, 16383	rx/tx
CHANNEL LIB STORE	0x26	2-128	0-513, 16383	rx/tx

function		number	channel*1)	rx/tx
INPATCH LIB STORE	0x27	1-32	256, 16383	rx/tx
OUTPATCH LIB STORE	0x28	1-32	256, 16383	rx/tx
Bus to Stereo LIB STORE	0x29	1-32	256, 16383	rx/tx
Surround Monitor LIB STORE	0x2A	1-32	256, 16383	rx/tx
AUTOMIX LIB STORE	0x2B	1-16	256, 16383	rx/tx

\*1) 0:CH1 - 95:CH96, 128:BUS1 - 135:BUS8, 256:AUX1 - 267:AUX12, 384:MATRIX1L - 391:MATRIX4R, 512:STEREO L - 513:STEREO R

Use 256 if the recall destination or store source is a single data item.

Effect is 0:Effect1 - 7:Effect8, GEQ is 0:GEQ1 - 5:GEQ6

If the store destination is 16383 (0x3FFF), this indicates that the library data has been changed by an external cause (such as bulk reception) (only transmitted by the DM2000)

\*2) This is also transmitted when a program that is not assigned in the [Program Change Table] is recalled. (Normally, it is transmitted by Program Change messages.)

\*3) Varies with the firmware version.

**13.4.15 Parameter change (Function call: title)**

**Reception**

If [Parameter change RX] is ON and the [Rx CH] matches the Device Number included in the SUB STATUS, these messages are received. If [Parameter change ECHO] is ON, these messages are echoed. When this is received, the title of the specified memory/library will be changed.

**Transmission**

In response to a request, a Parameter Change message will be transmitted on the [Rx CH].

If [Parameter change ECHO] is ON, this message will be retransmitted without change.

```

STATUS 11110000 F0 System exclusive message
ID No. 01000011 43 Manufacture's ID number (YAMAHA)
SUB STATUS 0001nnnn 1n n=0-15 (Device number=MIDI Channel)
GROUP ID 00111110 3E MODEL ID (digital mixer)
MODEL ID 01111111 7F Universal
ADDRESS 00010000 10 Function call
0100ffff 4f title
0mmmmmmm mh number High
0mmmmmmm ml number Low
DATA 0ddddd dd title 1
:
:
:
0ddddd dd title x (depend on the library)
EOX 11110111 F7 End of exclusive
    
```

function		number	size
SCENE LIB TITLE	0x40	0-99,256 (0:response only)	16
EQ LIB TITLE	0x41	1-200 (1-40:response only)	16
GATE LIB TITLE	0x42	1-128 (1-4:response only)	16
COMP LIB TITLE	0x43	1-128 (1-36:response only)	16
EFF LIB TITLE	0x44	1-128 (1-xx*):response only)	16
GEQ LIB TITLE	0x45	0-128 (0:response only)	16
CHANNEL LIB TITLE	0x46	0-128 (0-1:response only)	16
INPATCH LIB TITLE	0x47	0-32 (0:response only)	16
OUTPATCH LIB TITLE	0x48	0-32 (0:response only)	16
Bus to Stereo LIB TITLE	0x49	0-32 (0:response only)	16
Surround Monitor LIB TITLE	0x4A	0-32 (0:response only)	16
AUTOMIX LIB TITLE	0x4B	1-16	16

\* Varies with the firmware version.

**13.4.16 Parameter request (Function call: title)**

**Reception**

If [Parameter change RX] is ON and the [Rx CH] matches the Device Number included in the SUB STATUS, these messages are received. If [Parameter change ECHO] is ON, these messages are echoed. When this is received, a Parameter Change message will be transmitted on the [Rx CH].

Refer to the above table for the Functions and Numbers.

```

STATUS 11110000 F0 System exclusive message
ID No. 01000011 43 Manufacture's ID number (YAMAHA)
    
```

SUB STATUS	0011nnnn	3n	n=0-15 (Device number=MIDI Channel)
GROUP ID	00111110	3E	MODEL ID (digital mixer)
MODEL ID	01111111	7F	Universal
ADDRESS	00010000	10	Function call
	0100ffff	4f	
TITLE	0mmmmmm	mh	number High
	0mmmmmm	ml	number Low
EOX	11110111	F7	End of exclusive

**13.4.17 Parameter change (Function call: scene/library clear)**

**Reception**

If [Parameter change RX] is ON and the [Rx CH] matches the Device Number included in the SUB STATUS, these messages are received. If [Parameter change ECHO] is ON, these messages are echoed. When this is received, the specified memory/library will be cleared.

**Transmission**

If [Parameter change ECHO] is ON, this message will be retransmitted without change.

STATUS	11110000	F0	System exclusive message
ID No.	01000011	43	Manufacturer's ID number (YAMAHA)
SUB STATUS	0001nnnn	1n	n=0-15 (Device number=MIDI Channel)
GROUP ID	00111110	3E	MODEL ID (digital mixer)
MODEL ID	01111111	7F	Universal
ADDRESS	00010000	10	Function call
	0110ffff	6f	clear function
	0mmmmmm	mh	number High
	0mmmmmm	ml	number Low
EOX	11110111	F7	End of exclusive

function	number
SCENE LIB CLEAR	0x60 1-99
EQ LIB CLEAR	0x61 41-200
GATE LIB CLEAR	0x62 5-128
COMP LIB CLEAR	0x63 37-128
EFF LIB CLEAR	0x64 xx(*)-128
GEQ LIB CLEAR	0x65 1-128
CHANNEL LIB CLEAR	0x66 2-128
INPATCH LIB CLEAR	0x67 1-32
OUTPATCH LIB CLEAR	0x68 1-32
Bus to Stereo LIB CLEAR	0x69 1-32
Surround Monitor LIB CLEAR	0x6A 1-32
AUTOMIX LIB CLEAR	0x6B 1-16

\* Varies with the firmware version.

**13.4.18 Parameter change (Function call: pair)**

**Reception**

If [Parameter change RX] is ON and the [Rx CH] matches the Device Number included in the SUB STATUS, these messages are received. If [Parameter change ECHO] is ON, these messages are echoed. When this is received, pairing will be enabled/disabled for the specified channel. (Otherwise, these messages are reserved for future use.)

STATUS	11110000	F0	System exclusive message
ID No.	01000011	43	Manufacturer's ID number (YAMAHA)
SUB STATUS	0001nnnn	1n	n=0-15 (Device number=MIDI Channel)
GROUP ID	00111110	3E	MODEL ID (digital mixer)
MODEL ID	01111111	7F	Universal
ADDRESS	00010001	11	Function call Pair
	0000ffff	0f	function
	0sssssss	sh	Source channel H
	0sssssss	sl	Source channel L
DATA	0ddddddd	dh	Destination channel H
	0ddddddd	dl	Destination channel L
EOX	11110111	F7	End of exclusive

function	channel
PAIR ON with COPY	0x00 *1)
PAIR ON with RESET BOTH	0x01 *1)
PAIR OFF	0x02 *1)

\*1) 0:CH1 - 95:CH96, 128:BUS1 - 135:BUS8, 256:AUX1 - 267:AUX12

- In the case of PAIR, you must specify channels for which pairing is possible.
- In the case of PAIR ON with COPY, you must specify Source Channel as the copy source, and Destination Channel as the copy destination.

**13.4.19 Parameter change (Function call: effect)**

**Reception**

If [Parameter change RX] is ON and the [Rx CH] matches the Device Number included in the SUB STATUS, these messages are received. If [Parameter change ECHO] is ON, these messages are echoed. When this is received, the corresponding effect's function activates (depending on the effect type).

STATUS	11110000	F0	System exclusive message
ID No.	01000011	43	Manufacturer's ID number (YAMAHA)
SUB STATUS	0001nnnn	1n	n=0-15 (Device number=MIDI Channel)
GROUP ID	00111110	3E	MODEL ID (digital mixer)
MODEL ID	01111111	7F	Universal
ADDRESS	00010010	12	Function call Effect Event
	0000ffff	0f	function
	00000000	00	
	0ppppppp	pp	Release:0, Press:1
DATA	00000000	00	
	0eeeeeee	ee	Effect number (0:Effect1 - 7:Effect8)
EOX	11110111	F7	End of exclusive

function	channel
Freeze Play button	0x00 0:Effect1 - 7:Effect8
Freeze Record button	0x01 0:Effect1 - 7:Effect8
Auto Pan 5.1 Trigger Button	0x02 0:Effect1 - 7:Effect8
Auto Pan 5.1 Reset Button	0x03 0:Effect1 - 7:Effect8

- This does not activate when the effect type is different.

**13.4.20 Parameter Change (Sort table data)**

**Reception**

If [Parameter change RX] is ON and the [Rx CH] matches the Device Number included in the SUB STATUS, these messages are received. If [Parameter change ECHO] is ON, these messages are echoed. The Scene memory Sort table is updated as soon as the messages are received.

If Studio Manager performs a scene memory sort, it will transmit this data to the DM2000.

**Transmission**

When scene memory sort is executed on the DM2000, the memory sort table will be transmitted to Studio Manager. Studio Manager will sort the memories according to this data.

STATUS	11110000	F0	System exclusive message
ID No.	01000011	43	Manufacturer's ID number (YAMAHA)
SUB STATUS	0001nnnn	1n	n=0-15 (Device number=MIDI Channel)
GROUP ID	00111110	3E	MODEL ID (digital mixer)
MODEL ID	00001110	06	DM2000
ADDRESS	00010011	13	Library sort table
	0000ffff	0f	Library type
DATA	0ddddddd	ds	Data
	:	:	
	:	:	
	0ddddddd	de	Data
EOX	11110111	F7	End of exclusive

8-7 conversion is performed on the data area in the same way as for bulk.

**13.4.21 Parameter Request (Sort table data)**

**Reception**

This is received if [Parameter change RX] is ON and the [Rx CH] matches the device number included in the SUB STATUS.  
 This is echoed if [Parameter change ECHO] is ON.  
 Sort table data is transmitted as Parameter Change messages on the [Rx CH] channel.

```
STATUS      11110000 F0 System exclusive message
ID No.      01000011 43 Manufacture's ID number (YAMAHA)
SUB STATUS  0011nnnn 3n n=0-15 (Device number=MIDI Channel)
GROUP ID    00111110 3E MODEL ID (digital mixer)
MODEL ID    00000110 06 DM2000
ADDRESS     00010011 13 Library sort table
            0000ffff 0f Library type
EOX         11110111 F7 End of exclusive
```

**13.4.22 Parameter change (Function call: attribute)**

**Reception**

This is received if [Parameter change RX] is ON and the [Rx CH] matches the device number included in the SUB STATUS.  
 This is echoed if [Parameter change ECHO] is ON.  
 When this is received, the attribute of the specified memory/library will be changed.

**Transmission**

In response to a request, a Parameter Change message will be transmitted on the [Rx CH].  
 If [Parameter change ECHO] is ON, this message will be retransmitted without change.

```
STATUS      11110000 F0 System exclusive message
ID No.      01000011 43 Manufacture's ID number (YAMAHA)
SUB STATUS  0001nnnn 1n n=0-15 (Device number=MIDI Channel)
GROUP ID    00111110 3E MODEL ID (digital mixer)
MODEL ID    01111111 7F Universal
ADDRESS     00010100 14 Function call
            0000ffff 0f attribute
            0mmmmmmm mh number High
            0mmmmmmm ml number Low
DATA        0ttttttt th attribute (protect:0x0001,
            0ttttttt tl normal:0x0000)
EOX         11110111 F7 End of exclusive
```

function	number
SCENE LIB ATTRIBUTE	0x00 0-99 (0:response only)
AUTOMIX LIB ATTRIBUTE	0x0B 1-16

**13.4.23 Parameter request (Function call: attribute)**

**Reception**

This is received if [Parameter change RX] is ON and the [Rx CH] matches the device number included in the SUB STATUS. This is echoed if [Parameter change ECHO] is ON.  
 When this is received, a Parameter Change message will be transmitted on the [Rx CH].  
 Refer to the above table for the Functions and Numbers.

```
STATUS      11110000 F0 System exclusive message
ID No.      01000011 43 Manufacture's ID number (YAMAHA)
SUB STATUS  0011nnnn 3n n=0-15 (Device number=MIDI Channel)
GROUP ID    00111110 3E MODEL ID (digital mixer)
MODEL ID    01111111 7F Universal
ADDRESS     00010100 14 Function call
            0000ffff 0f
ATTRIBUTE   0mmmmmmm mh number High
            0mmmmmmm ml number Low
EOX         11110111 F7 End of exclusive
```

**13.4.24 Parameter change (Function call: link)**

**Reception**

This is received if [Parameter change RX] is ON and the [Rx CH] matches the device number included in the SUB STATUS. This is echoed if [Parameter change ECHO] is ON.

When this is received, the patch link data of the specified scene will be modified.

**Transmission**

In response to a request, a Parameter Change message will be transmitted on the [Rx CH].  
 If [Parameter change ECHO] is ON, this message will be retransmitted without change.

```
STATUS      11110000 F0 System exclusive message
ID No.      01000011 43 Manufacture's ID number (YAMAHA)
SUB STATUS  0001nnnn 1n n=0-15 (Device number=MIDI Channel)
GROUP ID    00111110 3E MODEL ID (digital mixer)
MODEL ID    01111111 7F Universal
ADDRESS     00010100 14 Function call
            0010ffff 2f link
            0mmmmmmm mh number High
            0mmmmmmm ml number Low
DATA        0iiiiiii ih inpatch
            0iiiiiii il
            0ooooooo oh outpatch
            0ooooooo ol
EOX         11110111 F7 End of exclusive
```

function	number
SCENE LIB LINK	0x20 0-99 (0:response only)

**13.4.25 Parameter request (Function call: link)**

**Reception**

This is received if [Parameter change RX] is ON and the [Rx CH] matches the device number included in the SUB STATUS. This is echoed if [Parameter change ECHO] is ON.  
 When this is received, a Parameter Change message will be transmitted on the [Rx CH].  
 Refer to the above table for the Functions and Numbers.

```
STATUS      11110000 F0 System exclusive message
ID No.      01000011 43 Manufacture's ID number (YAMAHA)
SUB STATUS  0011nnnn 3n n=0-15 (Device number=MIDI Channel)
GROUP ID    00111110 3E MODEL ID (digital mixer)
MODEL ID    01111111 7F Universal
ADDRESS     00010100 14 Function call
            0010ffff 2f link
            0mmmmmmm mh number High
            0mmmmmmm ml number Low
EOX         11110111 F7 End of exclusive
```

**13.4.26 Parameter change (Key remote)**

**Reception**

If [Parameter change RX] is ON and the [Rx CH] matches the Device Number included in the SUB STATUS, these messages are received. If [Parameter change ECHO] is ON, these messages are echoed.  
 When this is received, the same processing that is executed when the key specified by Address is pressed (released).

**Transmission**

If [Parameter change ECHO] is ON, this message will be retransmitted without change.

```
STATUS      11110000 F0 System exclusive message
ID No.      01000011 43 Manufacture's ID number (YAMAHA)
SUB STATUS  0001nnnn 1n n=0-15 (Device number=MIDI Channel)
GROUP ID    00111110 3E MODEL ID (digital mixer)
MODEL ID    00000110 06 DM2000
ADDRESS     00100000 20 Key remote
            0kkkkkkk kk Key address H
            0kkkkkkk kk Key address M
            0kkkkkkk kk Key address L
DATA        0ppppppp pp Release:0, Press:1
EOX         11110111 F7 End of exclusive
```

**13.4.27 Parameter change (Remote meter)**

When transmission is enabled by receiving a Request of Remote meter, the specified meter information is transmitted every 50 msec for 10 seconds. When you want to transmit meter information continuously, a Request must be transmitted continuously within every 10 seconds.

**Reception**

This is echoed if [Parameter change ECHO] is ON.

**Transmission**

When transmission has been enabled by a Request, the parameter specified by Address will be transmitted on the [Rx CH] channel at 50 msec intervals for a duration of 10 seconds.

Transmission will be disabled if the power is turned off and on again, or if the PORT setting is changed.

If [Parameter change ECHO] is ON, this message will be retransmitted without change.

```

STATUS      11110000 F0 System exclusive message
ID No.      01000011 43 Manufacture's ID number (YAMAHA)
SUB STATUS  0001nnnn 1n n=0-15 (Device number=MIDI Channel)
GROUP ID    00111110 3E MODEL ID (digital mixer)
MODEL ID    00000110 06 DM2000
ADDRESS     00100001 21 Remote meter
             0mmmmmmmm mm ADDRESS UL
             0mmmmmmmm mm ADDRESS LU
             0mmmmmmmm mm ADDRESS LL
DATA        0ddddddd dd data1 H
             0ddddddd dd Data1 L
:
:
EOX         11110111 F7 End of exclusive

```

**13.4.28 Parameter request (Remote meter)****Reception**

If [Parameter change RX] is ON and the [Rx CH] matches the Device Number included in the SUB STATUS, these messages are received. If [Parameter change ECHO] is ON, these messages are echoed.

When this is received, data of the specified address is transmitted on the [Rx CH] at intervals of 50 msec as a rule, for a period of 10 seconds.

If Address UL= 0x7F is received, transmission of all meter data will be halted immediately. (disable)

**Transmission**

If [Parameter change ECHO] is ON, this message will be retransmitted without change.

```

STATUS      11110000 F0 System exclusive message
ID No.      01000011 43 Manufacture's ID number (YAMAHA)
SUB STATUS  0011nnnn 3n n=0-15 (Device number=MIDI Channel)
GROUP ID    00111110 3E MODEL ID (digital mixer)
MODEL ID    00000110 06 DM2000
ADDRESS     00100001 21 Remote meter
             0mmmmmmmm mm ADDRESS UL
             0mmmmmmmm mm ADDRESS LU
             mmmmmmmmm mm ADDRESS LL
             0ccccccc ch Count H
             0ccccccc c1 Count L
EOX         11110111 F7 End of exclusive

```

**13.4.29 Parameter change (Remote time counter)**

When transmission is enabled by receiving a Request of Remote Time Counter, the Time Counter data is transmitted every 50 msec for 10 seconds. When you want to transmit Counter information continuously, a Request must be transmitted within every 10 seconds.

**Reception**

This is echoed if [Parameter change ECHO] is ON.

**Transmission**

When transmission is enabled by receiving a Request, the Time Counter information is transmitted on [RxCH] channel every 50 msec for 10 seconds.

Transmission will be disabled if the power is turned off and on again, or if the PORT setting is changed.

If [Parameter change ECHO] is ON, this message will be retransmitted without change.

```

STATUS      11110000 F0 System exclusive message

```

```

ID No.      01000011 43 Manufacture's ID number (YAMAHA)
SUB STATUS  0001nnnn 1n n=0-15 (Device number=MIDI Channel)
GROUP ID    00111110 3E MODEL ID (digital mixer)
MODEL ID    00000110 06 DM2000
ADDRESS     00100010 22 Remote Time counter
             0000tttt 0t 0:Time code, 1:Measure.Beat.Clock
             0ddddddd dd Hour / Measure H
             0ddddddd dd Minute / Measure L
DATA        0ddddddd dd Second / Beat
             0ddddddd dd Frame / Clock
EOX         11110111 F7 End of exclusive

```

**13.4.30 Parameter request (Remote time counter)****Reception**

If [Parameter change RX] is ON and the [Rx CH] matches the Device Number included in the SUB STATUS, these messages are received. If [Parameter change ECHO] is ON, these messages are echoed.

When this is received, the Time Counter information is transmitted on the [Rx CH] channel every 50 msec for 10 seconds.

When the second byte of Address is received on 0x7F, data transmission will be halted immediately. (disable)

**Transmission**

If [Parameter change ECHO] is ON, this message will be retransmitted without change.

```

STATUS      11110000 F0 System exclusive message
ID No.      01000011 43 Manufacture's ID number (YAMAHA)
SUB STATUS  0011nnnn 3n n=0-15 (Device number=MIDI Channel)
GROUP ID    00111110 3E MODEL ID (digital mixer)
MODEL ID    00000110 06 DM2000
ADDRESS     00100010 22 Remote Time counter
             0ddddddd dd 0:Transmission request,
             0x7F:Transmission stop request
EOX         11110111 F7 End of exclusive

```

**13.4.31 Parameter change (Automix status)**

When transmission is enabled by receiving a Request of Automix status, the Automix Status data is transmitted every second for 10 seconds. When you want to transmit the Automix Status information continuously, the Request must be transmitted continuously minimum within 10 seconds interval. The data is transmitted continuously while the transmission is enabled, even when the Automix Status on the DM2000 has been changed.

**Reception**

This is echoed if [Parameter change ECHO] is ON.

**Transmission**

When the transmission is set to enable by receiving a Request. The Automix Status data is transmitted on the [Rx CH] channel every second for 10 seconds. The data is transmitted continuously while the transmission is enabled, even when the Automix Status on the DM2000 has been changed. Transmission will be disabled if the power is turned off and on again, or if the PORT setting is changed.

If [Parameter change ECHO] is ON, this message will be retransmitted without change.

```

STATUS      11110000 F0 System exclusive message
ID No.      01000011 43 Manufacture's ID number (YAMAHA)
SUB STATUS  0001nnnn 1n n=0-15 (Device number=MIDI Channel)
GROUP ID    00111110 3E MODEL ID (digital mixer)
MODEL ID    00000110 06 DM2000
ADDRESS     00100011 23 Automix status
             00000000 00
             0000dddd 0d Automix status H
             0000dddd 0d Automix status L
EOX         11110111 F7 End of exclusive

```



**13.4.32 Parameter request (Automix status)****Reception**

If [Parameter change RX] is ON and the [Rx CH] matches the Device Number included in the SUB STATUS, these messages are received. If [Parameter change ECHO] is ON, these messages are echoed.

When the data is received, the Automix Status data is transmitted on the [Rx CH] every second for 10 seconds.

When the second byte of Address is received on 0x7F, data transmission will be halted immediately (disable).

**Transmission**

If [Parameter change ECHO] is ON, this message will be retransmitted without change.

STATUS	11110000	F0	System exclusive message
ID No.	01000011	43	Manufacture's ID number (YAMAHA)
SUB STATUS	0011nnnn	3n	n=0-15 (Device number=MIDI Channel)
GROUP ID	00111110	3E	MODEL ID (digital mixer)
MODEL ID	00000110	06	DM2000
ADDRESS	00100011	23	Automix status
	0ddddddd	dd	0:Transmission request, 0x7F:Transmission stop request
EOX	11110111	F7	End of exclusive

# Appendix D: Options

---

## MB2000 Peak Meter Bridge

### Installation

- 1 Attach the brackets to the meter bridge.
- 2 Screw the four fixing screws into the DM2000, but don't tighten them fully.
- 3 Align the meter bridge with the four screws, and then tighten the screws.
- 4 Connect the meter bridge cable to the DM2000's METER port.

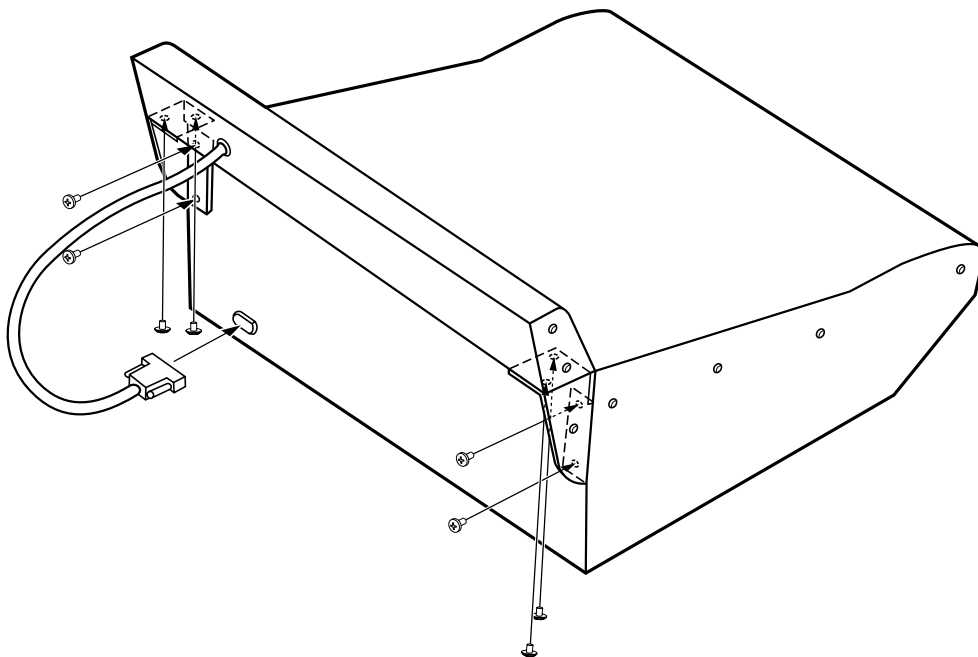

## Meter Bridge Controls

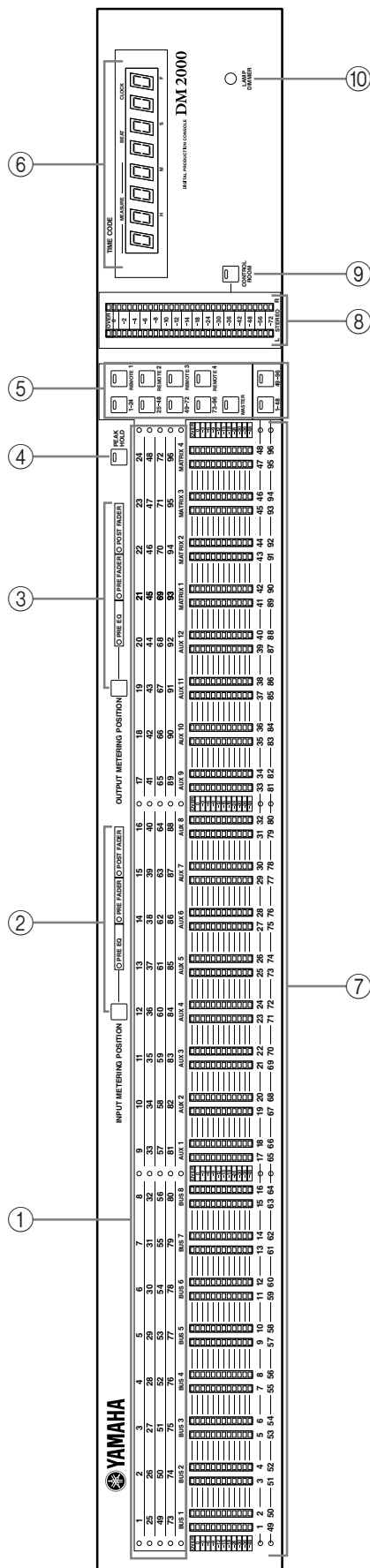

- ① **Channel indicators**  
These indicators show which channels are currently being metered: Input Channels 1–24, 25–48, 49–72, 73–96, or the Output Channels (Bus Outs 1–8, Aux Sends 1–12, Matrix Sends 1–4).
- ② **INPUT METERING POSITION button & indicators**  
This button is used to set the metering position for Input Channels to pre-EQ, pre-fader, or post-fader. It works in unison with the PRE EQ, PRE FADER, and POST FADER buttons for Input Channels on the Meter pages. The indicators show the current setting.
- ③ **OUTPUT METERING POSITION button & indicators**  
This button is used to set the metering position for Output Channels to pre-EQ, pre-fader, or post-fader. It works in unison with the PRE EQ, PRE FADER, and POST FADER buttons for Output Channels on the Meter pages. The indicators show the current setting.
- ④ **PEAK HOLD button**  
This button is used to turn the Peak Hold function on and off. Its indicator lights up when Peak Hold is on. It works in unison with the PEAK HOLD buttons on the Meter pages.
- ⑤ **LAYER buttons**  
These buttons are used to select Layers for metering. The button indicator for the currently selected Layer lights up. The [1–24], [25–48], [49–72], and [73–96] buttons select the Input Layers. The [MASTER] button selects the Master Layer. The REMOTE [1–4] buttons select the Remote Layers. If the Meter Follow Layer preference is on (see page 276), these Layers are selected automatically when the LAYER buttons on the DM2000 are pressed. The [1–48] button selects Input Channels 1–48, and the [49–96] button selects Input Channels 49–96, allowing you to meter up to 48 channels simultaneously.
- ⑥ **TIMECODE counter**  
This counter displays the current timecode position. When the Pro Tools Remote Layer is selected, it displays the Pro Tools timecode.
- ⑦ **Meters**  
These 12-segment LED meters display the signal levels of the channels on the currently selected Layer.
- ⑧ **STEREO meters**  
These 32-segment meters display the signal levels of the Stereo Out.
- ⑨ **CONTROL ROOM button**  
This button is used to display the level of the Control Room signal on the STEREO meters. Its indicator lights up when the STEREO meters are displaying Control Room levels.
- ⑩ **LAMP DIMMER knob**  
This knob is used to adjust the brightness of the optional LA1800 Light Goosenecks.

## SP2000 Wooden Side Panels

Attach the left side panel as shown below. Attach the right side panel in the same way.

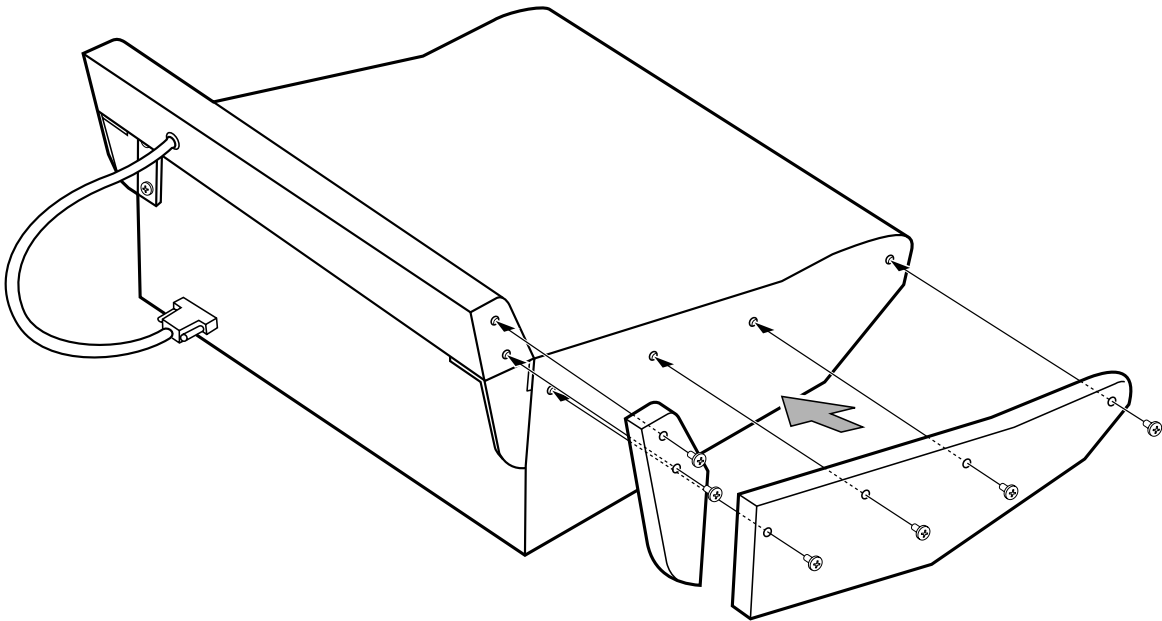

# Index

## Symbols

+48V ON/OFF switches 21

## Numerics

1–24 button 34  
 25–48 button 34  
 2TR I/O  
   channel status 73  
   dithering outputs 73  
   patching digital outputs 81  
   patching direct outs 81  
   patching inputs 77  
   sampling rate conversion 69  
 2TR IN ANALOG 1 +4 dB (BAL) 47  
 2TR IN ANALOG 2 –10 dBV (UNBAL)  
   47  
 2TR IN DIGITAL AES/EBU 1 & 2 49  
 2TR IN DIGITAL COAXIAL 3 49  
 2TR OUT DIGITAL AES/EBU 1 & 2 49  
 2TR OUT DIGITAL COAXIAL 3 48  
 2TR OUT DIGITAL OUT PATCH page  
   81  
 3-1 surround mode 97  
 31-band GEQs 183  
 49–72 button 34  
 5.1 surround mode 97  
 6.1 surround mode 97  
 73–96 button 34  
 96 kHz, 88.2 kHz, 48 kHz, 44.1 kHz,  
   selecting 67

## A

ABORT/UNDO button 36  
 Absolute mode, automix 196  
 AC IN connector 50  
 AD inputs  
   connectors 46  
   in detail 64  
   patching 77  
   patching output channel insert ins  
     80  
   summary 21  
   talkback 164  
 AD8HR/AD824 control 267  
 Adat I/O card 70  
 Add-On Effects 178  
 AES/EBU I/O card 70  
 ALL CLEAR button 35  
 ALT LAYER 63  
 AMP SIMULATE 317  
 Analog I/O & the AD input section  
   chapter 64  
 Architecture  
   channels 17  
   I/O 17

ASSIGN 1 button, control room 43  
 ASSIGN 1 button, control room  
   surround 43  
 ASSIGN 1–4 buttons, encoder mode 24  
 ASSIGN 2 button, control room 43  
 ASSIGN 2 button, control room  
   surround 43  
 Assigning  
   control changes 219  
   parameters to encoders 62  
   program changes 218  
   *See also* Routing  
   targets to remote layers 253  
   user defined keys 270  
 ATT control 33  
 ATTACK control 31  
 Attenuating  
   cascade inputs 76  
   channel signals 130  
 AUDITION button 37  
 Auto AUX/MATRIX Display preference  
   275  
 AUTO buttons  
   about 21  
   in detail 199  
   Pro Tools 226  
   STEREO 34  
   using 202  
 Auto channel select 60  
 Auto Channel Select preference 275  
 Auto DELAY Display preference 274  
 Auto Direct Out On preference 276  
 Auto DYNAMICS Display preference  
   275  
 Auto EQ Edit In preference 277  
 Auto EQUALIZER Display preference  
   275  
 Auto Inc TC Capture preference 277  
 AUTO PAN 5.1 327  
 Auto PAN/SURROUND Display  
   preference 275  
 Auto PHASE/INSERT Display  
   preference 274  
 Auto ROUTING Display preference 274  
 Auto scene memory update 186  
 Auto SOLO Display preference 275  
 Auto WORD CLOCK Display  
   preference 275  
 Automix  
   about 193  
   absolute mode 196  
   AUTO buttons 199  
   cascading consoles 74  
   copying events 209  
   deleting events 213  
   duplicating events 213  
   erasing events 209  
   EVENT EDIT page 213  
   EVENT JOB page 209  
   event list 213  
   FADER EDIT pages 199  
   features 18  
   inserting events 213

library 173  
 MAIN page 194  
 MEMORY page 199  
 merging events 209  
 motors on/off 200  
 moving events 209  
 offline editing 209  
 overwrite parameters 196  
 parameter recording 206  
 playback 208  
 protecting memories 173  
 punching individual parameters 207  
 recording 202  
 relative mode 196  
 rerecording 205  
 return mode 195  
 storing to smartmedia 271  
 storing via bulk dump 220  
 takeover mode 195  
 time signature map 202  
 timecode offset 194  
 timecode source 201  
 touch sense in/out 200  
 undo 197  
 update to end 194  
 what's recorded 193  
 Automix chapter 193  
 AUTOMIX MAIN page 194  
 AUTOMIX MEMORY page 173, 199  
 AUTOMIX page 173  
 AUTOMIX section  
   about 36  
   automix 198  
   Pro Tools 233  
 Automix Store Undo preference 278  
 AUTOPAN 315  
 AUTO-REC button 36  
 AUX 11 button 42  
 AUX 1–12 buttons 23  
 AUX 12 button 42  
 AUX button, automix 37  
 AUX FADER VIEW page 153  
 AUX ON button, automix 37  
 AUX PAN CH pages 116  
 AUX SELECT section  
   about 23  
   Pro Tools 228  
   using 110  
 AUX SEND CH pages 112  
 Aux sends  
   attenuating 130  
   automix 193  
   channel library 166  
   channel strip displays 56  
   compressors 137  
   copying 155  
   Copying channel fader positions 118  
   delay 141  
   EQ 131  
   Excluding certain channels 117  
   fixed mode 110  
   follow surround pan 145  
   grouping faders 146

- grouping mutes 149
  - inserts 135
  - link pan to input channels 116
  - master level setting 119
  - metering 129
  - Mix minus 117
  - muting 112, 119
  - naming 156
  - pairing 144
  - pan modes 116
  - panning 116
  - patching GEQs 82
  - patching to 2TR digital outputs 81
  - patching to effects 78
  - patching to input channels 77
  - patching to omni outs 80
  - patching to slot outputs 79
  - pre/post fader 111
  - scene recall safe 190
  - setting levels 111
  - soloing 142
  - variable mode 110
  - viewing fader settings 151
  - viewing parameter settings 150
  - viewing settings 114
- Aux sends chapter 110
- AUX/MATRIX SEND section
- about 30
  - muting aux sends 112
  - muting matrix sends 122
  - setting aux send levels 111
  - setting matrix send levels 121
- AUX/MTRX button, encoder mode 23
- AUX/MTRX button, fader mode 24
- ## B
- BACK button 39
- Balance
- matrix sends 126
  - stereo out 106
- BANK button 30
- BANK indicators 30
- Bars, time signature map 202
- BASS MANAGEMENT 162
- BI-DIRECTIONAL, cascade setting 76
- Bit shift attenuation 130
- Bulk dump 220
- BULK DUMP page 220
- BUS button, control room surround 43
- BUS FADER VIEW page 152
- Bus outs
- attenuating 130
  - automix 193
  - bus to stereo library 169
  - channel library 166
  - compressors 137
  - copying 155
  - delay 141
  - EQ 131
  - grouping faders 146
  - grouping mutes 149
  - inserts 135
  - level setting 108
  - metering 129
  - muting 108
  - naming 156
  - pairing 144
  - patching GEQs 82
  - patching to 2TR digital outputs 81
  - patching to input channels 77
  - patching to omni outs 80
  - patching to slot outputs 79
  - routing to 93
  - routing to stereo out 109
  - scene recall safe 190
  - soloing 142
  - viewing fader settings 151
  - viewing parameter settings 150
- Bus outs chapter 107
- BUS TO STEREO LIBRARY page 169
- BUS TO STEREO page 109
- Bypassing effects 177
- ## C
- CARD Slot. *See* Smartmedia
- Cascade COMM Link preference 276
- CASCADE IN page 76
- CASCADE IN port 49
- CASCADE IN port pin assignments 350
- CASCADE OUT page 76
- CASCADE OUT port 49
- CASCADE OUT port pin assignments 350
- Cascading consoles
- about 74
  - attenuating cascade inputs 76
  - hookup examples 75
  - linked functions 74
  - master setting 76
  - turning off cascade outputs 76
- Category, channel status 73
- CH DIRECT OUT DESTINATION pages 81
- CH EQUALIZER LIBRARY page 172
- CH FADER EDIT pages 199
- CH FADER VIEW page 151
- CH GATE EDIT page 86
- CH PARAMETER VIEW page 150
- CH SURROUND EDIT page 100
- Channel Copy Parameter preference 276
- CHANNEL COPY section
- about 33
  - using 155
- Channel ID preference 276
- Channel IDs 57
- CHANNEL INSERTS button 26
- CHANNEL LIBRARY page 166
- Channel names
- assigning 156
  - displaying 57
- Channel Short Name preference 276
- Channel status monitor 73
- CHANNEL STATUS MONITOR page 73
- Channel strip displays
- about 22
  - displaying channel names 57
  - in detail 55
  - Pro Tools 227
  - user defined remote layers 255
- Channel strips
- about 21
  - Pro Tools 225
  - selecting layers 58
  - user defined remote layers 254
- CHORUS 313
- CHORUS 5.1 327
- CLEAR button 42
- Clear Edit Channel after REC preference 277
- Clearing library memories 165
- Clearing scene memories 188
- Combination effects 175
- Common channel functions chapter 127
- COMP 5.1 330
- COMP EDIT page 139
- COMP indicator 31
- COMP LIBRARY page 171
- COMP ON button 31
- COMPAND 5.1 330
- Compander 137
- Compressors
- channel strip displays 55
  - grouping input channels 88
  - grouping output channels 140
  - library 171
  - order 137
  - parameter table 345
  - presets 137
  - using 137
- Confirmation messages 54
- Contrast control 27
- CONTROL CHANGE ASSIGN TABLE page 219
- Control changes
- assignments 219
  - echoing 217
  - omni 217
  - receive enable 217
  - storing assignments to smartmedia 271
  - storing assignments via bulk dump 220
  - transmit enable 217
- CONTROL port 49
- CONTROL port pin assignments 350
- Control room
- dimmer level 159
  - monitoring 158
  - patching to 2TR digital outputs 81
  - setup 159
- CONTROL ROOM button 42
- CONTROL ROOM LEVEL control 44
- CONTROL ROOM SETUP page 159
- Control surface
- features 19
  - illustration 20

- Control surface & rear panel chapter 20
- Cooling fan 50
- COPY button 33
- Copy Initial Fader preference 277
- Copy, channel status 73
- Copying automix events 209
- Copying channels 155
- Cubase SX 253
- Current scene display 52
- Currently selected channel
  - display 52
  - name display 52
  - selecting 59
- Currently selected page
  - page number display 52
  - selecting 53
  - title display 52
- Cursor buttons 40
- D**
- DATA button 24
- Data entry & transport section
  - about 39
  - machine transport 257
  - Pro Tools 237
- Date preference 277
- DAW
  - MIDI port setup 216
  - See Pro tools
- DAW CONTROL 256
- DEC button 40
- DECAY control 31
- DEL, title edit window 54
- Delay effects 174
- DELAY LCR 312
- DELAY SCALE 142
- DELAY section
  - about 29
  - using 141
- DELAY+ER. 322
- DELAY+REV 323
- DELAY->ER. 323
- DELAY->REV 324
- Delaying channel signals
  - channel strip displays 55
  - how to 141
- Deleting automix events 213
- Digital I/O & cascading chapter 66
- Dimensions 351
- DIMMER button 44
- Dimmer level, control room 159
- Dimmer level, talkback 164
- DIO button 24
- DIO Warning preference 275
- DIRECT button 28
- Direct outs
  - patching 81
  - routing to 93
- Display
  - about 27
  - confirmation messages 54
  - history function 53
  - in detail 52
  - items 54
  - parameter windows 54
  - Pro Tools 224
- DISPLAY ACCESS section
  - about 24
  - Pro Tools 229
- Display Brightness preference 277
- DISPLAY buttons
  - AUTOMIX 36
  - AUX SELECT 23
  - AUX/MATRIX SEND 30
  - DELAY 29
  - DYNAMICS 30
  - EFFECTS/PLUG-INS 26
  - ENCODER MODE 23
  - EQUALIZER 33
  - LOCATOR 37
  - MATRIX SELECT 22
  - MONITOR 42
  - PAN/SURROUND 31
  - PHASE/INSERT 29
  - ROUTING 28
  - SCENE MEMORY 35
  - TRACK ARMING 35
  - USER DEFINED KEYS 37
- DISPLAY HISTORY buttons 39
- DIST->DELAY 324
- DISTORTION 317
- DITHER page 73
- Dithering digital outputs 73
- DIV (divergence) 101
- Double channel 72
- Double speed 72
- Drop Out Time preference 278
- DUAL PITCH 316
- Ducking, input channels 85
- Duplicating automix events 213
- DYNA. FILTER 318
- DYNA. FLANGE 318
- DYNA. PHASER 318
- Dynamic effects 175
- DYNAMICS section
  - about 30
  - compressors 139
  - gates 85
- Dynamics. See Gates and Compressors
- E**
- EARLY REF. 310
- ECHO 312
- Edit buffer 185
- Edit indicators
  - display 52
  - SCENE MEMORY section 185
- Editing
  - automix events 209
  - compressors 137
  - effects 177
  - gates 85
  - GEQs 183
  - library memory titles 165
  - plug-ins 181
  - scene memory titles 188
- EFFECT button 32
- EFFECT EDIT page 177
- EFFECT INPUT PATCH pages 78
- EFFECT INPUT/OUTPUT METER
  - page 129
- EFFECT LIBRARY page 168
- Effects
  - about 174
  - automix 193
  - bypassing 177
  - editing 177
  - features 18
  - library 168
  - metering 129
  - parameter tables 310
  - patching inputs 78
  - patching output channel insert ins 80
  - patching outputs 77
  - presets 174
- EFFECTS/PLUG-INS 1–8 buttons 26
- EFFECTS/PLUG-INS section
  - about 26
  - editing effects 177
  - editing GEQs 183
  - editing plug-ins 181
  - Pro Tools 230
- ÉIA 209
- Emphasis, channel status 73
- ENABLE button 36
- ENCODER MODE ASSIGN page 62
- ENCODER MODE section
  - about 23
  - Pro Tools 228
  - using 61
- Encoder modes, selecting 61
- Encoders
  - about 21
  - assignable parameter list 63
  - assigning parameters 62
  - automix punch in/out 207
  - channel strip displays 56
  - panning input channels 95
  - patching inputs & outputs 83
  - Pro Tools 226
  - selecting encoder modes 61
  - setting aux send levels 111
  - setting matrix send levels 122
  - user defined remote layers 254
- END button 38
- ENTER button 40

- EQ
  - automix 193
  - channel strip displays 55
  - EQUALIZER EDIT page 134
  - features 18
  - frequency 133
  - gain 133
  - grouping input channels 87
  - grouping output channels 135
  - library 172
  - presets 132
  - Q 133
  - using 131
- EQ button, automix 27
- EQ displays 33
- EQ GAIN controls 33
- EQ ON button 33
- EQUALIZER EDIT page 134
- EQUALIZER section
  - about 33
  - using 133
- Erasing automix events 209
- EVENT EDIT page 213
- Event editing 209
- EVENT JOB page 209
- Event list, automix 213
- Expander 137
- F**
- F1–F4 buttons 27
- FADER button 24
- FADER button, automix 37
- Fader edit mode 196
- FADER MODE section
  - about 24
  - Pro Tools 229
  - using 60
- Fader REC Accuracy preference 278
- Fader Resolution 218
- Fader Touch Sense preference 276
- Faders
  - about 22
  - auto channel select 60
  - automix punch in/out 207
  - aux send master levels 119
  - bus out levels 108
  - fader edit mode 196
  - Group Master 92, 147
  - grouping input channels 91
  - grouping output channels 146
  - input channel levels 90
  - matrix send master levels 125
  - motors on/off 200
  - Pro Tools 226
  - selecting fader modes 60
  - setting aux send levels 111
  - setting matrix send levels 121
  - STEREO 34
  - stereo out level 105
  - touch sense in/out, automix 200
  - touch sense select 60
  - user defined remote layers 254
- Fading scenes 189
- Fast Meter Fall Time preference 275
- FB/MIX control 29
- FB/MIX indicators 29
- Features 17
- FF button 39
- FILE page 273
- Fixed mode, aux sends 110
- FLANGE 313
- FLANGE 5.1 328
- Fluorescent displays 22
- FOLLOW PAN button 28
- FOLLOW SURROUND 78
- Follow surround pan, aux sends 145
- Formatting smartmedia 273
- FORWARD button 39
- Frame Jump Error preference 278
- Frame rate, automix 201
- FREQUENCY controls 33
- FREQUENCY indicators 33
- FX 174
- G**
- GAIN control, dynamics 31
- GAIN controls, AD inputs 21
- Gang mode
  - aux send pan 116
  - input channel pan 96
- GATE indicator 31
- GATE LIBRARY page 170
- GATE ON button 31
- GATE REVERB 310
- GATE/COMP button 31
- Gates
  - channel strip displays 55
  - library 170
  - parameter table 345
  - presets 85
  - using 85
- General DAW 253
- GEOs
  - about 183
  - editing 183
  - features 18
  - library 168
  - linking 183
  - patching 82
- Global Fade Time 190
- Global Paste 191
- GLOBAL PASTE DESTINATION SCENE page 192
- GLOBAL PASTE SOURCE CH SELECT page 191
- GLOBAL RECALL SAFE 190
- GPI 264
  - REC LAMP 266
- GPI SETUP page 264
- GR meters
  - compressors 140
  - gates 86
- GRAB button 32
- GRAPHIC EQUALIZER EDIT page 183
- GRAPHIC EQUALIZER INSERT page 82
- GRAPHIC EQUALIZER LIBRARY page 168
- GRAPHIC EQUALIZERS button 26
- Grounding screw 50
- GROUP button 25
- Group Master 90, 92, 147, 149
- Grouping
  - features 18
  - input channel compressors 88
  - input channel EQs 87
  - input channel faders 91
  - input channel mutes 89
  - output channel compressors 140
  - output channel EQs 135
  - output channel faders 146
  - output channel mutes 149
  - track arming 263
- Guitar effects 175
- H**
- HA CONTROL page 268
- HIGH EQ 131
- HIGHER SAMPLE RATE DATA TRANSFER FORMAT page 72
- HIGH-MID EQ 131
- History function 53
- HOLD control 31
- Horizontal pairing 144
- HQ. PITCH 315
- I**
- IEEE1394 70
- IN button 38
- INC button 40
- Individual mode
  - aux send pan 116
  - input channel pan 96
- Initial Data Nominal preference 275
- Initializing the DM2000 282
- Input & output patching chapter 77
- INPUT A & B (BAL) connectors 46
- INPUT CH ATTENUATOR/SHIFTER pages 130
- INPUT CH AUX VIEW pages 114
- INPUT CH DELAY pages 141
- INPUT CH FADE TIME pages 189
- INPUT CH FADER GROUP page 91
- INPUT CH INSERT IN PATCH pages 78
- INPUT CH METER page 128
- INPUT CH MUTE GROUP page 89
- INPUT CH PAIR pages 145
- INPUT CH PAN page 96
- INPUT CH PAN pages 96
- INPUT CH PHASE pages 84
- INPUT CH ROUTING pages 94
- INPUT CH SURROUND pages 101
- INPUT CHANNEL NAME page 156



- Input channels
  - attenuating 130
  - automix 193
  - channel library 166
  - compressors 137
  - copying 155
  - delay 141
  - EQ 131
  - gating 85
  - grouping compressors 88
  - grouping EQs 87
  - grouping faders 91
  - grouping mutes 89
  - inserts 135
  - level setting 90
  - metering 128
  - muting 88
  - naming 156
  - pairing 144
  - panning 95
  - patching 77
  - reversing phase 84
  - selecting layers 58
  - soloing 142
  - viewing fader settings 151
  - viewing parameter settings 150
- Input channels chapter 84
- INPUT COMP LINK page 88
- INPUT EQUALIZER LINK page 87
- INPUT FADER GROUP MASTER page 92
- INPUT FADER MASTER 92
- INPUT MUTE MASTER 90
- INPUT PATCH button 25
- INPUT PATCH LIBRARY page 167
- INPUT PATCH pages 77
- Input patching 77
- INPUT PORT NAME page 82
- Input port naming 82
- INS, title edit window 54
- INSERT IN & OUT +4dB (BAL)
  - connectors 46
- INSERT ON button 29
- INSERT ON/OFF switches 21
- INSERT pages 136
- Insert Time Link preference 278
- Inserting automix events 213
- Inserts
  - AD insert on/off switches 21
  - channel strip displays 55
  - order 137
  - patching input channel insert ins 78
  - patching insert outs to effects inputs 78
  - patching insert outs to omni outs 80
  - patching insert outs to slot outputs 79
  - patching output channel insert ins 80
  - patching outs to 2TR digital outputs 81
  - using 135
- Installing I/O cards 71
- INTERNAL EFFECTS button 26
- Internal effects, plug-ins & GEQs chapter 174
- Internal timecode source 201
- Internet, yamaha web site 6
- Inverse gang mode
  - aux send pan 116
  - input channel pan 96
- Inverting input channel phase 84
- J**
- Joystick
  - about 32
  - panning input channels 95
  - reverb 5.1 effect 326
  - surround pan 99
- Joystick Auto Grab preference 276
- K**
- KEYBOARD connector 48
- Keyboard, using 55
- Keyin source 86
- L**
- L button 31
- LARGE CONTROL ROOM MONITOR
  - OUT +4 dB (BAL) 47
- Last solo mode 143
- LAYER section
  - about 34
  - selecting layers 58
- Layers
  - encoder modes 61
  - fader modes 60
  - selecting 58
  - selecting channels 59
- Learn function
  - user defined plug-ins 181
  - user defined remote layers 254
- Left Tab Scroll button 27
- LEVEL controls, aux/matrix sends 30
- LFE 100
- Libraries
  - about 165
  - automix 173, 193
  - bus to stereo 169
  - channel 166
  - compressor 171
  - effects 168
  - EQ 172
  - gate 170
  - GEQ 168
  - input patch 167
  - output patch 167
  - specifications 346
  - storing to smartmedia 271
  - storing via bulk dump 220
  - surround monitor 173
  - using 165
- Libraries chapter 165
- LINK button 32
- Link Capture & Locate Memory
  - preference 277
- LISTEN, solo 143
- LOAD page 272
- Loading from smartmedia 272
- LOCATE MEMORY 1–8 buttons 38
- LOCATE MEMORY page 260
- LOCATOR section
  - about 37
  - Pro Tools 235
  - using 258
- Lock Time preference 278
- Long channel names
  - assigning 156
  - displaying 57
- Long port names 82
- LOOP button 38
- LOW EQ 131
- LOW-MID EQ 131
- M**
- M. BAND DYNA. 329
- MACHINE CONFIGURATION page 256
- MACHINE CONTROL 256
- Machine control
  - about 256
  - arming tracks 261
  - locator 258
  - machine configuration 256
  - master track arming 262
  - MTR track arming 262
  - pre-roll, post-roll, roll-back 260
  - REMOTE port setup 257
  - scrub & shuttle 258
  - setting locate memories 260
  - track arming groups 263
  - transport buttons 257
- Macintosh
  - configuring for Pro Tools 221
  - MIDI port setup 216
  - USB driver 215
- Managing smartmedia 273
- MASTER button, layer 34
- MASTER button, locator 39
- MASTER button, track arming 35
- Master layer, selecting 58
- MASTER METER page 129
- MASTER PARAMETER VIEW page 151
- MASTER TRACK ARMING
  - CONFIGURATION page 262
- MATRIX 1–4 buttons 22
- MATRIX FADER VIEW page 153
- MATRIX PAN page 123
- MATRIX SELECT section
  - about 22
  - Pro Tools 228
  - using 121
- MATRIX SEND pages 122

- Matrix sends
  - attenuating 130
  - automix 193
  - balance 126
  - channel library 166
  - channel strip displays 56
  - compressors 137
  - copying 155
  - delay 141
  - EQ 131
  - grouping faders 146
  - grouping mutes 149
  - inserts 135
  - level setting 125
  - metering 129
  - muting 122, 125
  - naming 156
  - panning 123
  - patching GEQs 82
  - patching to 2TR digital outputs 81
  - patching to omni outs 80
  - patching to slot outputs 79
  - pre/post fader 121
  - scene recall safe 190
  - setting levels 121
  - soloing 142
  - viewing fader settings 151
  - viewing parameter settings 150
  - viewing settings 124
- Matrix sends chapter 121
- MATRIX VIEW page 124
- MB2000 peak meter bridge 386
- Measures, time signature map 202
- Merging automix events 209
- METER button 25
- Meter Follow Layer preference 276
- METER port 49
- Meter, time signature map 202
- Metering
  - effects 129
  - input channels 128
  - metering position 127
  - output channels 129
  - stereo out 130
- METERING POSITION page 127
- MIDI
  - bulk dump 220
  - control change messages 219
  - data format 369
  - features 19
  - I/O ports 215
  - MIDI SETUP page 217
  - parameter change messages 219
  - port setup 216
  - ports 49
  - program change messages 218
  - supported messages 215
- MIDI button 25
- MIDI chapter 215
- MIDI clock
  - automix timecode source 201
- MIDI SETUP page 217
- MIDI Warning preference 275
- MIDI/TO HOST SETUP page 216
- mini YGDAL. *See* Slots
- Mix minus 117
- Mix solo mode 143
- Mix Update Confirmation preference 277
- Mixdown, solo status 143
- mLAN I/O card 70
- MMC. *See* Machine control
- MOD. DELAY 311
- MOD. FILTER 317
- Modulation-based effects 175
- MONITOR ALIGNMENT 163
- MONITOR MATRIX 161
- MONITOR section 42
- Monitoring
  - configuring surround monitoring 161
  - control room 158
  - control room setup 159
  - studio 159
  - surround 160
- Monitoring & talkback chapter 158
- MONO button 44
- MONO DELAY 311
- Motors on/off 200
- Moving automix events 209
- MS decoding 146
- MS microphone 103
- MTC TIME CODE INPUT connector 48
- MTC, timecode source 201
- MTR button 38
- MTR TRACK ARMING CONFIGURATION page 262
- MULTI FILTER 325
- Multi-effects 174
- Muting
  - automix 193
  - aux sends 112, 119
  - bus outs 108
  - Group Master 90, 149
  - grouping input channels 89
  - grouping output channels 149
  - input channels 88
  - matrix sends 122, 125
  - stereo out 105
- N**
- Name Input Auto Copy 82
- Naming channels 156
- Naming library memories 165
- Naming scene memories 187
- NEVER LATCH TALKBACK 164
- Nominal Pan preference 275
- O**
- OCTA REVERB 327
- Offline editing 209
- Offsetting automix timecode 194
- OMNI OUT +4dB (BAL) 47
- OMNI OUT PATCH page 80
- Omni outs
  - about 65
  - patching 80
  - patching direct outs 81
- Omni, MIDI 217
- OMS
  - configuring for Pro Tools 222
  - installing for Pro Tools 221
- ON button, automix 37
- ON button, delay section 29
- ON buttons
  - Pro Tools 226
  - See also* Grouping
  - See also* Muting
  - STEREO 34
  - user defined remote layers 254
- ON buttons, aux/matrix sends 30
- ONLINE button 38
- Operating basics chapter 51
- Operation Lock 280
- OPERATION LOCK page 280
- Options 6
- Order, inserts/compressors 137
- Oscillator 279
- OSCILLATOR page 279
- Other functions chapter 269
- OUT button 38
- OUTPUT ATTENUATOR page 130
- OUTPUT CHANNEL NAME page 157
- Output channels
  - attenuating 130
  - compressors 137
  - copying 155
  - delay 141
  - EQ 131
  - grouping compressors 140
  - grouping EQs 135
  - grouping faders 146
  - grouping mutes 149
  - inserts 135
  - library 166
  - metering 129
  - naming 156
  - pairing 144
  - selecting master layer 58
  - soloing 142
  - viewing fader settings 151
  - viewing parameter settings 150
- OUTPUT COMP LINK page 140
- OUTPUT DELAY page 141
- OUTPUT EQUALIZER LINK page 135
- OUTPUT FADE TIME page 189
- OUTPUT FADER GROUP MASTER page 148
- OUTPUT FADER GROUP page 146
- OUTPUT FADER MASTER 148
- OUTPUT INSERT IN PATCH page 80
- OUTPUT MUTE GROUP page 149
- OUTPUT MUTE MASTER 149
- OUTPUT PAIR page 145
- OUTPUT PATCH button 25
- OUTPUT PATCH LIBRARY page 167
- Output patching 79

OUTPUT PORT NAME page 82  
 Output port naming 82  
 Overwrite parameters 196

## P

P2. *See* Machine control  
 Package contents 6  
 PAD switches 21  
 Pages  
   history function 53  
   page number display 52  
   page tab scroll arrows 53  
   selecting 53  
   tabs 53  
   title display 52  
 PAIR button 25  
 Pair Confirmation preference 275  
 Pairing channels 144  
   features 18  
   pan modes 96  
 PAN button 23  
 PAN button, automix 37  
 PAN control 32  
 PAN display 31  
 PAN/SURROUND section  
   about 31  
   joystick and surround pan 99  
   panning input channels 95  
 Panner 252  
 Panning  
   automix 193  
   aux sends 116  
   channel strip displays 56  
   input channels 95  
   matrix sends 123  
   modes 96  
 Parameter boxes 54  
 Parameter change messages 219  
 Parameter controls 1–4 27  
 Parameter Up/Down buttons 26  
 Parameter wheel 40  
 Parameter windows 54  
 PASTE button 33  
 Patch Confirmation preference 275  
 PATCH LINK 188  
 Patch select window 83  
 Patching  
   2TR digital outputs 81  
   direct outs 81  
   effects inputs 78  
   features 18  
   GEQs 82  
   input channel insert ins 78  
   input channels 77  
   input library 167  
   inputs 77  
   omni outs 80  
   output channel insert ins 80  
   output library 167  
   outputs 79

  patch select window 83  
   slot outputs 79  
   surround monitor 163  
   with the encoders 83

Patterns 100

PC

  configuring for Pro Tools 221  
   MIDI port setup 216  
   USB driver 215

Peak hold 127

PEAK indicators 21

Phantom power switches 21

Phase button 29

Phase, input channel phase reverse 84

PHASE/INSERT section

  about 29  
   reversing phase 84  
   using inserts 135

PHASER 314

Phone jacks 45

PHONES jack 41

PHONES LEVEL control 41

Phono connectors 45

Picture of control surface 20

PLAY button, automix 197

PLAY button, transport 39

Playing back an automix 208

PLUG-IN EDIT page 181

PLUG-IN SETUP page 180

Plug-ins

  about 179  
   configuring 180  
   editing 181  
   MIDI port setup 216  
   storing to smartmedia 271  
   storing via bulk dump 220

PLUG-INS button 26

Port ID preference 276

Port ID/Name on FL Display preference  
   276

Port IDs 82

Port names 82

Port Short Name preference 276

Position, compressors 139

POST button 38

Post/pre. *See* Pre/post

Post-roll, machine control 260

Power cord 51

POWER switch 50

Powering up the DM2000 51

PRE button 37

Pre/post

  aux sends 111  
   matrix sends 121  
   metering 127  
   solo 143

PREFERENCES1 page 274

PREFERENCES2 page 276

PREFERENCES3 page 277

Pre-roll, machine control 260

Presets

  compressors 137  
   effects 174  
   EQ 132  
   gates 85

Pro tools

  arming parameters for automation  
     251  
   assigning inputs to channels 239  
   assigning inserts/plug-ins 244  
   assigning outputs to channels 240  
   assigning send destinations 242  
   automation 250  
   AUTOMIX section 233  
   AUX SELECT section 228  
   bypassing all plug-ins 246  
   bypassing individual plug-ins 246  
   channel strip displays 227  
   channel strips 225  
   configuring 222  
   configuring Macintosh computers  
     221  
   configuring sends as pre or post 242  
   configuring the DM2000 222  
   configuring Windows computers  
     221  
   control surface operation 224  
   data entry & transport section 237  
   display 224  
   DISPLAY ACCESS section 229  
   editing plug-ins 245  
   EFFECTS/PLUG-INS section 230  
   ENCODER MODE section 228  
   FADER MODE section 229  
   flip mode 243  
   LOCATOR section 235  
   making fine adjustments to the  
     selected region 248  
   MATRIX SELECT section 228  
   muting channels 241  
   muting sends 243  
   navigating the edit window 247  
   OMS 221  
   Panner 252  
   panning channels 241  
   panning sends 243  
   resetting faders, sends, panpots &  
     plug-ins 247  
   scrolling windows 238  
   scrub & shuttle 249  
   selecting channels 239  
   setting channel levels 240  
   setting send levels 243  
   setting the automation mode 250  
   soloing channels 241  
   TRACK ARMING section 233  
   trim mode 251  
   USER DEFINED KEYS section 234  
   zooming 248  
 Pro tools remote layer chapter 221  
 PROGRAM CHANGE ASSIGN TABLE  
   page 218

- Program changes
    - assignments 218
    - echoing 217
    - omni 217
    - receive enable 217
    - storing assignments to smartmedia 271
    - storing assignments via bulk dump 220
    - transmit enable 217
  - Protecting automix memories 173
  - Protecting scene memories 188
  - PS/2 keyboard 55
  - Punch in/out, individual parameters 207
- Q**
- Q controls 33
  - Q indicators 33
  - Q, EQ 133
  - QUICK PUNCH button 38
- R**
- R button 31
  - RANGE control 31
  - RATIO control 31
  - RCA connectors 45
  - Read-only memories 165
  - Rear panel 45
  - REC button, automix 36
  - REC button, transport 39
  - REC LAMP 266
  - RECALL button 36
  - Recall Confirmation preference 275
  - RECALL SAFE page 190
  - Recalling
    - memory libraries 165
    - scene memories 187
  - Receive channel 217
  - Receive Full Frame Message preference 278
  - Recording an automix 202
  - Recording, solo status 143
  - REHEARSAL button 39
  - RELATIVE button 36
  - Relative mode, automix 196
  - RELEASE control 31
  - REMOTE 1–4 buttons 34
  - REMOTE button 24
  - Remote control chapter 253
  - Remote layers
    - about 253
    - assigning targets 253
    - MIDI port setup 216
    - Pro Tools 221
    - selecting 58
  - REMOTE page 253
  - REMOTE page, Pro Tools 224
  - REMOTE page, user defined 254, 255
  - REMOTE port 49
  - REMOTE port pin assignments 350
  - REMOTE PORT SETUP page 257, 267
  - Requesting bulk dump 220
  - Rerecording an automix 205
  - RETURN button 36
  - Return mode, automix 195
  - RETURN TO ZERO button 38
  - REV+CHORUS 319
  - REV+FLANGE 320
  - REV+SYMPHO. 321
  - REV->CHORUS 319
  - REV->FLANGE 320
  - REV->PAN 322
  - REV->SYMPHO. 321
  - REVERB 5.1 326
  - Reverb effects 174
  - REVERB HALL 310
  - REVERB PLATE 310
  - REVERB ROOM 310
  - REVERB STAGE 310
  - REVERSE GATE 310
  - Reversing input channel phase 84
  - REW button 39
  - Right Tab Scroll button 27
  - RING MOD. 316
  - ROLL BACK button 38
  - Roll-back, machine control 260
  - ROTARY 316
  - Routing
    - channel strip displays 55
    - input channels 93
  - ROUTING 1–8 buttons 29
  - ROUTING page 94
  - ROUTING section
    - about 28
    - using 93
  - Routing ST Pair Link preference 276
- S**
- Safe channels, automix 200
  - Safe channels, scene memories 190
  - Safe channels, solo 143
  - Sampling rate
    - 2TR I/O SRC 69
    - display 52
    - setting 67
    - slot SRC 72
  - SAMPLING RATE CONVERTER page 69
  - SAVE page 271
  - Saving to smartmedia 271
  - Scene down button 36
  - Scene MEM Auto Update preference 276
  - Scene memories
    - about 185
    - auto scene memory update 186
    - automix 193
    - cascading consoles 74
    - current scene display 52
    - edit buffer 185
    - edit indicator 185
    - fading scenes 189
    - memory #0 186
    - MIDI program changes 218
    - protecting 188
    - recalling 187
    - safe channels 190
    - sorting 191
    - storing 187
    - storing to smartmedia 271
    - storing via bulk dump 220
    - undo memory 186
    - what's stored 185
  - Scene memories chapter 185
  - Scene memory display 35
  - SCENE MEMORY page 188
  - SCENE MEMORY section
    - about 35
    - using 187
  - SCENE MEMORY SORT page 191
  - Scene up button 36
  - Scroll arrows, pages 53
  - SCRUB button 40
  - SEL buttons
    - about 21
    - displaying long channel names 57
    - pairing channels 144
    - Pro Tools 226
    - selecting channels 59
    - STEREO 60
  - SEL MODE, solo 143
  - SELECTED CHANNEL section 28
  - Selecting
    - encoder modes 61
    - fader modes 60
    - layers 58
    - pages 53
  - Selecting channels
    - auto channel select 60
    - channel strip displays 55
    - how to 59
    - touch sense select 60
  - SERIAL TO HOST port 48
  - MIDI 215
  - timecode source 201
  - SET button 38
  - SET SPL85 161
  - Setting levels
    - aux send masters 119
    - aux sends 111
    - bus outs 108
    - input channels 90
    - matrix send masters 125
    - matrix sends 121
    - stereo out 105
  - SETUP button 24
  - Shadow memories 186
  - SHIFT LOCK, title edit window 54
  - Short channel names 156
  - Short port names 82
  - Show Compact Size preference 278
  - SHUTTLE button 39
  - SIGNAL indicators 21
  - Slate 163
  - SLATE button 44
  - SLOT OUTPUT PATCH pages 79

- Slots
    - about 50, 70
    - available cards 70
    - channel status 73
    - dithering outputs 73
    - double channel 72
    - double speed 72
    - installing cards 71
    - MIDI 215
    - patching direct outs 81
    - patching inputs 77
    - patching output channel insert ins 80
    - patching outputs 79
    - timecode source 201
  - SMALL button 44
  - SMALL CONTROL ROOM MONITOR
    - OUT +4 dB (BAL) 47
  - SMALL TRIM control 41
  - Smartmedia
    - card slot 22
    - formatting 273
    - handling 5
    - loading 272
    - managing 273
    - saving 271
  - SMPTE TIME CODE INPUT connector 48
  - Solo
    - cascading consoles 74
    - configuring 143
    - safe channels 143
    - sel mode 143
    - status 143
    - trim 143
    - using 142
  - Solo Bus to Studio Out preference 276
  - SOLO buttons
    - about 22
    - Pro Tools 226
    - using 142
  - SOLO CONTRAST control 42
  - SOLO indicator 42
  - SOLO SETUP page 143
  - SOLO TRIM 143
  - Soloing channels 142
  - Sonic Spec 17
  - Sorting scene memories 191
  - SP2000 wooden side panels 388
  - SPEAKER SETUP 161
  - Specifications 341
  - SRC. *See* Sampling rate
  - STATUS, solo 143
  - STEREO 2TR A1 button 43
  - STEREO 2TR A2 button 43
  - STEREO 2TR D1 button 43
  - STEREO 2TR D2 button 43
  - STEREO 2TR D3 button 43
  - STEREO button, control room 43
  - STEREO button, routing 28
  - STEREO button, studio 42
  - STEREO DELAY 311
  - STEREO fader 34
  - STEREO FADER VIEW page 154
  - Stereo link, compressors 139
  - Stereo link, gates 86
  - Stereo link, surround pan 101
  - STEREO METER page 130
  - Stereo out
    - attenuating 130
    - automix 193
    - balance 106
    - channel library 166
    - compressors 137
    - copying 155
    - delay 141
    - EQ 131
    - grouping faders 146
    - grouping mutes 149
    - inserts 135
    - level setting 105
    - metering 129, 130
    - muting 105
    - naming 156
    - patching GEQs 82
    - patching to 2TR digital outputs 81
    - patching to omni outs 80
    - patching to slot outputs 79
    - routing to 93
    - scene recall safe 190
    - viewing fader settings 151
    - viewing parameter settings 150
  - STEREO OUT +4 dB (BAL) 47
  - STEREO OUT -10 dBV (UNBAL) 47
  - Stereo out chapter 104
  - STEREO section 34
  - STOP button, automix 197
  - STOP button, transport 39
  - STORE button 36
  - Store Confirmation preference 275
  - Storing
    - library memories 165
    - scene memories 187
    - see also* Smartmedia
  - STUDIO LEVEL control 41
  - Studio manager port setup 216
  - STUDIO MONITOR OUT +4 dB (BAL) 46
  - Studio monitoring 159
  - SURROUND BUS SETUP page 99
  - SURROUND button, automix 37
  - SURROUND MODE SELECT page 97
  - SURROUND MONITOR LEVEL control 43
  - SURROUND MONITOR LIBRARY 173
  - SURROUND MONITOR page 160
  - SURROUND MONITOR PATCH page 163
  - SURROUND MONITOR SETUP page 161
  - Surround monitoring 160
    - configuring 161
    - library 173
    - patching slot inputs 163
    - patching to omni outs 80
    - patching to slot outputs 79
  - Surround pan
    - automix 193
    - aux send pan 145
    - channel page 101
    - edit page 100
    - features 19
    - joystick 99
    - selecting modes 97
    - using 97
  - Switching on the DM2000 51
  - SYMPHO 5.1 328
  - SYMPHONIC 314
- ## T
- Tabs, pages 53
  - Takeover mode, automix 195
  - Talkback
    - AD inputs 164
    - dimmer level 164
    - mic 41
    - setup 164
    - using 163
  - TALKBACK button 44
  - TALKBACK LEVEL control 41
  - TALKBACK SETUP page 164
  - Tascam I/O card 70
  - TC Drop Warning preference 275
  - Terminating wordclocks 68
  - THRESHOLD control 31
  - TIME control 29
  - TIME REFERENCE page 201
  - Time signature map, automix 202
  - TIME SIGNATURE page 202
  - Timecode
    - automix source 201
    - capturing, automix 213
    - capturing, locate memories 260
    - display 194
    - offset 194
  - Title edit window 54
  - Titling library memories 165
  - Titling scene memories 187
  - TO END 194
  - TOUCH SENSE button 37
  - Touch Sense Edit In All preference 278
  - Touch sense in/out, automix 200
  - Touch sense select
    - channel strip displays 55
    - using 60
  - TRACK ARMING 1-24 buttons 35
  - TRACK ARMING GROUP A-D buttons 35
  - TRACK ARMING GROUP page 263
  - TRACK ARMING section
    - about 35
    - Pro Tools 233
    - using 261
  - Transmit channel 217
  - Transmitting bulk dump 220
  - Transport. *See* Data entry & transport section
  - TREMOLO 315
  - Turning channels on or off. *See* Muting

Turning on the DM2000 51  
Type I/II EQ 134

## U

Undo automix 197  
Undo scene memory 186  
UPDATE 194  
USB TO HOST port 48  
    drivers 215  
    MIDI 215  
    timecode source 201  
USER ASSIGNABLE LAYER 269  
USER DEFINED KEY ASSIGN page 270  
USER DEFINED KEYS 1–16 buttons 37  
USER DEFINED KEYS section  
    about 37  
    Pro Tools 234  
    using 270  
User defined layers  
    automix 193  
    configuring 254  
    storing to smartmedia 271  
    storing via bulk dump 220  
    using 255  
User defined plug-ins  
    about 179  
    automix 193  
    configuring 180  
    editing 181  
    storing to smartmedia 271  
    storing via bulk dump 220  
UTILITY button 24

## V

Variable mode, aux sends 110  
Vertical pairing 144  
VIEW button 25  
Viewing channel fader settings  
    input channels 151  
    output channels 151  
Viewing channel parameter settings  
    input channels 150  
    output channels 150

## W

Waves Y56K plug-ins effects card 179  
Web site 6  
Welcome chapter 17  
Windows  
    configuring for Pro Tools 221  
    MIDI port setup 216  
    USB driver 215  
WORD CLOCK 75Ω ON/OFF  
    termination switch 48  
WORD CLOCK IN connector 48  
WORD CLOCK OUT 1 connector 48  
WORD CLOCK OUT 2 connector 48  
WORD CLOCK SELECT page 67  
Wordclocks  
    about 66  
    connections 66  
    selecting the source 67  
    terminating 68

## X

XLR connectors 45

## Y

Y56K plug-ins effects card 179  
Yamaha web site 6  
YGDAL. *See* Slots

# DM2000 Block Diagram

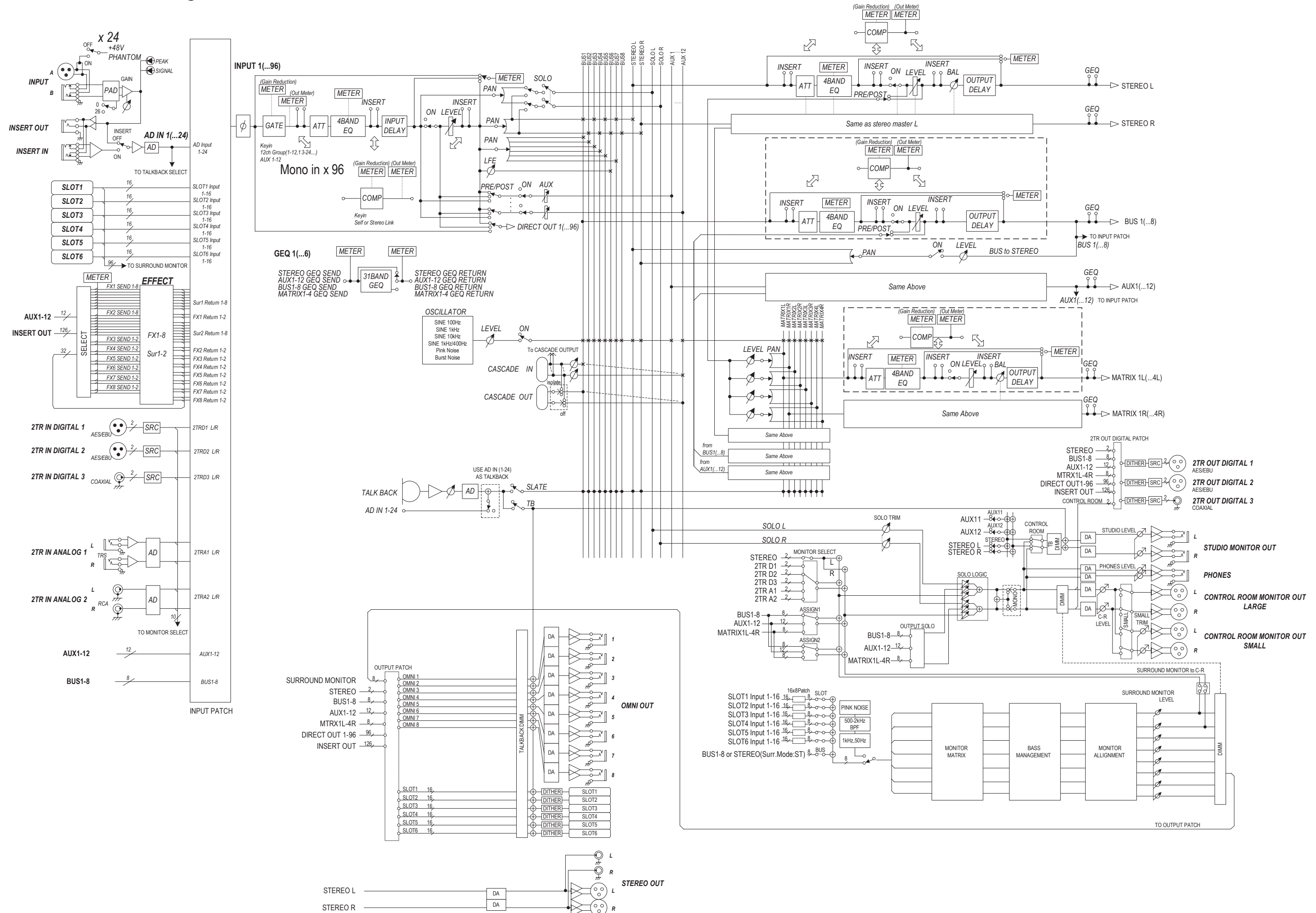

# DM2000 Level Diagram

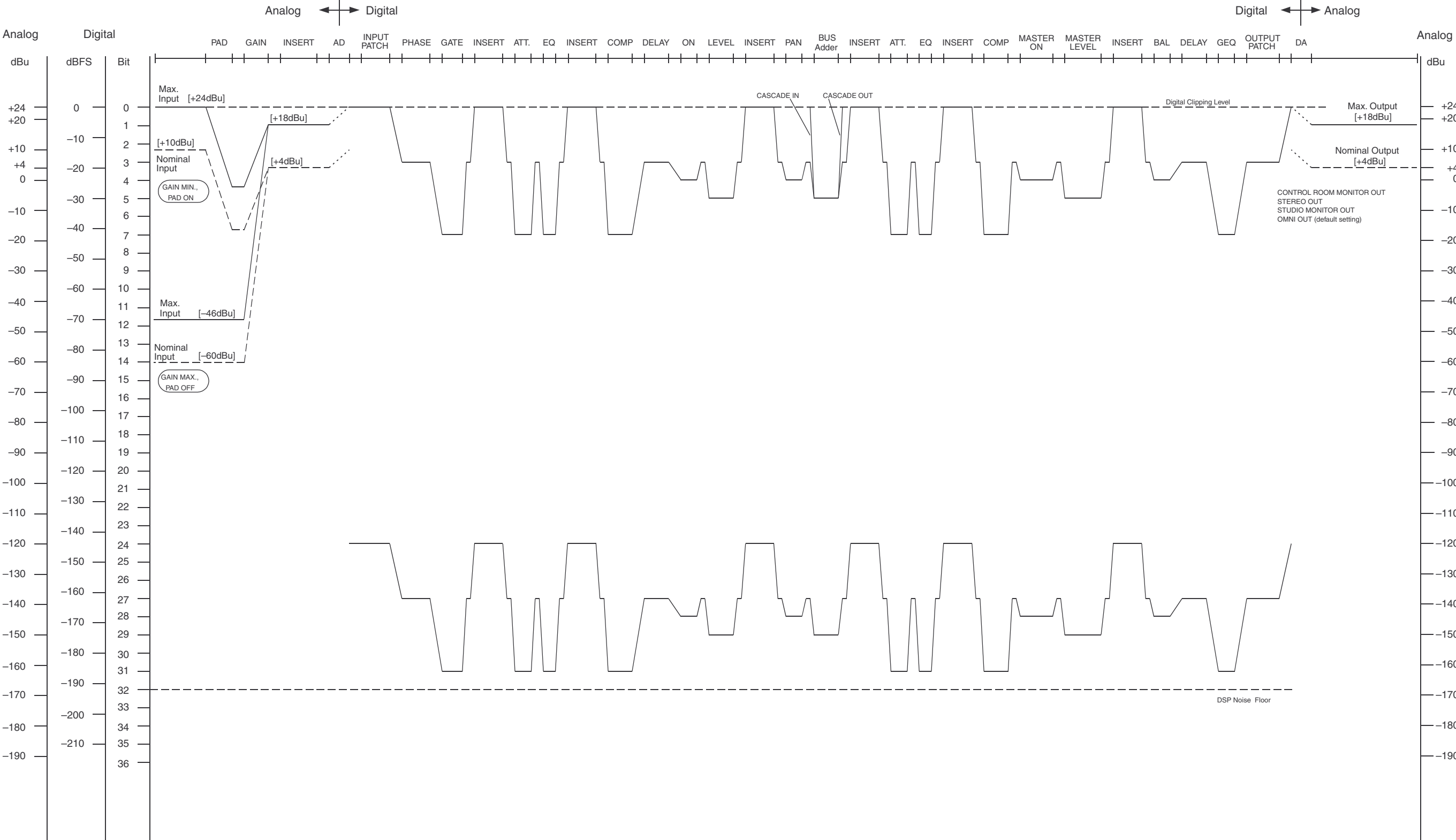

[0dBu = 0.775Vrms]  
 [0dBFS = Full Scale]



MIDI Implementation Chart

Function...		Transmitted	Recognized	Remarks
Basic Channel	Default Changed	1-16 1-16	1-16 1-16	Memorized
Mode	Default Messages Altered	X X *****	OMNI off/OMNI on X X	Memorized
Note Number	:True Voice	X *****	0-127 X	
Velocity	Note On Note Off	X X	O O	Effect Control
After Touch	Key's Ch's	X X	X X	
Pitch Bend		X	X	
Control Change	0-95,102-119	O	O	Assignable
Prog Change	:True#	0-127 *****	0-127 0-99	Assignable
System Exclusive		O	O	*1
System Common	:Song Pos :Song Sel :Tune	X X X	O X X	Automix
System Real Time	:Clock :Commands	X X	O O	Automix, Effect Control
Aux Messages	:Local ON/OFF :All Notes OFF :Active Sense :Reset	X X X X	X X O O	
Notes	MTC quarter frame message is recognized.(MTC IN & MIDI IN) *1: Bulk Dump/Request, Parameter Change/Request, and MMC. For MIDI Remote, ALL messages can be transmitted.			

Mode 1: OMNI ON, POLY  
Mode 3: OMNI OFF, POLY

Mode 2: OMNI ON, MONO  
Mode 4: OMNI OFF, MONO

O: Yes  
X: No

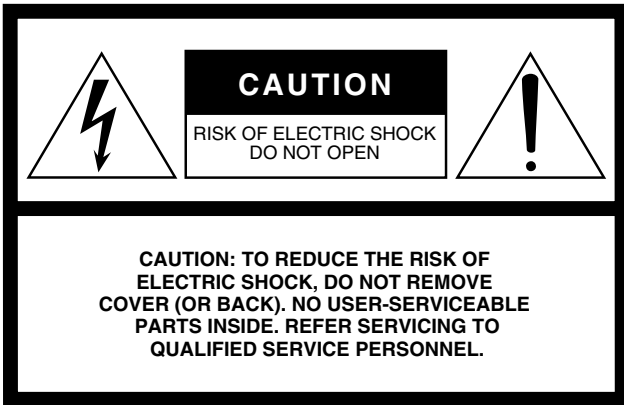

The above warning is located on the top, side, or rear of the unit.

## Explanation of Graphical Symbols

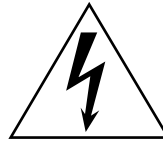

The lightning flash with arrowhead symbol within an equilateral triangle is intended to alert the user to the presence of uninsulated “dangerous voltage” within the product’s enclosure that may be of sufficient magnitude to constitute a risk of electric shock to persons.



The exclamation point within an equilateral triangle is intended to alert the user to the presence of important operating and maintenance (servicing) instructions in the literature accompanying the product.

## IMPORTANT SAFETY INSTRUCTIONS

- 1 Read these instructions.
- 2 Keep these instructions.
- 3 Heed all warnings.
- 4 Follow all instructions.
- 5 Do not use this apparatus near water.
- 6 Clean only with dry cloth.
- 7 Do not block any ventilation openings. Install in accordance with the manufacturer’s instructions.
- 8 Do not install near any heat sources such as radiators, heat registers, stoves, or other apparatus (including amplifiers) that produce heat.
- 9 Do not defeat the safety purpose of the polarized or grounding-type plug. A polarized plug has two blades with one wider than the other. A grounding type plug has two blades and a third grounding prong. The wide blade or the third prong are provided for your safety. If the provided plug does not fit into your outlet, consult an electrician for replacement of the obsolete outlet.
- 10 Protect the power cord from being walked on or pinched particularly at plugs, convenience receptacles, and the point where they exit from the apparatus.
- 11 Only use attachments/accessories specified by the manufacturer.
- 12 Use only with the cart, stand, tripod, bracket, or table specified by the manufacturer, or sold with the apparatus. When a cart is used, use caution when moving the cart/apparatus combination to avoid injury from tip-over.
- 13 Unplug this apparatus during lightning storms or when unused for long periods of time.
- 14 Refer all servicing to qualified service personnel. Servicing is required when the apparatus has been damaged in any way, such as power-supply cord or plug is damaged, liquid has been spilled or objects have fallen into the apparatus, the apparatus has been exposed to rain or moisture, does not operate normally, or has been dropped.



### WARNING

TO REDUCE THE RISK OF FIRE OR ELECTRIC SHOCK, DO NOT EXPOSE THIS APPARATUS TO RAIN OR MOISTURE.

For details of products, please contact your nearest Yamaha representative or the authorized distributor listed below.

Pour plus de détails sur les produits, veuillez-vous adresser à Yamaha ou au distributeur le plus proche de vous figurant dans la liste suivante.

Die Einzelheiten zu Produkten sind bei Ihrer unten aufgeführten Niederlassung und bei Yamaha Vertragshändlern in den jeweiligen Bestimmungsländern erhältlich.

Para detalles sobre productos, contacte su tienda Yamaha más cercana o el distribuidor autorizado que se lista debajo.

## NORTH AMERICA

### CANADA

**Yamaha Canada Music Ltd.**  
135 Milner Avenue, Scarborough, Ontario,  
M1S 3R1, Canada  
Tel: 416-298-1311

### U.S.A.

**Yamaha Corporation of America**  
6600 Orangethorpe Ave., Buena Park, Calif. 90620,  
U.S.A.  
Tel: 714-522-9011

## CENTRAL & SOUTH AMERICA

### MEXICO

**Yamaha de México S.A. de C.V.**  
Calz. Javier Rojo Gómez #1149,  
Col. Guadalupe del Moral  
C.P. 09300, México, D.F., México  
Tel: 55-5804-0600

### BRAZIL

**Yamaha Musical do Brasil Ltda.**  
Rua Joaquim Floriano, 913 - 4º andar, Itaim Bibi,  
CEP 04534-013 Sao Paulo, SP. BRAZIL  
Tel: 011-3704-1377

### ARGENTINA

**Yamaha Music Latin America, S.A.  
Sucursal de Argentina**  
Olga Cossetini 1553, Piso 4 Norte  
Madero Este-C1107CEK  
Buenos Aires, Argentina  
Tel: 011-4119-7000

### PANAMA AND OTHER LATIN AMERICAN COUNTRIES/ CARIBBEAN COUNTRIES

**Yamaha Music Latin America, S.A.**  
Torre Banco General, Piso 7, Urbanización Marbella,  
Calle 47 y Aquilino de la Guardia,  
Ciudad de Panamá, Panamá  
Tel: +507-269-5311

## EUROPE

### THE UNITED KINGDOM

**Yamaha Music U.K. Ltd.**  
Sherbourne Drive, Tilbrook, Milton Keynes,  
MK7 8BL, England  
Tel: 01908-366700

### GERMANY

**Yamaha Music Europe GmbH**  
Siemensstraße 22-34, 25462 Rellingen, Germany  
Tel: 04101-3030

### SWITZERLAND/LIECHTENSTEIN

**Yamaha Music Europe GmbH  
Branch Switzerland in Zürich**  
Seefeldstrasse 94, 8008 Zürich, Switzerland  
Tel: 01-383 3990

### AUSTRIA

**Yamaha Music Europe GmbH Branch Austria**  
Schleiergasse 20, A-1100 Wien, Austria  
Tel: 01-60203900

### CZECH REPUBLIC/SLOVAKIA/ HUNGARY/SLOVENIA

**Yamaha Music Europe GmbH Branch Austria**  
Schleiergasse 20, A-1100 Wien, Austria  
Tel: 01-602039025

### POLAND

**Yamaha Music Europe GmbH  
Branch Sp.z o.o. Oddzial w Polsce**  
ul. 17 Stycznia 56, PL-02-146 Warszawa, Poland  
Tel: 022-500-2925

### THE NETHERLANDS/ BELGIUM/LUXEMBOURG

**Yamaha Music Europe Branch Benelux**  
Clarissenhof 5-b, 4133 AB Vianen, The Netherlands  
Tel: 0347-358 040

### FRANCE

**Yamaha Musique France**  
BP 70-77312 Marne-la-Vallée Cedex 2, France  
Tel: 01-64-61-4000

### ITALY

**Yamaha Musica Italia S.P.A.  
Combo Division**  
Viale Italia 88, 20020 Lainate (Milano), Italy  
Tel: 02-935-771

### SPAIN/PORTUGAL

**Yamaha Música Ibérica, S.A.**  
Ctra. de la Coruna km. 17, 200, 28230  
Las Rozas (Madrid), Spain  
Tel: 91-639-8888

### SWEDEN

**Yamaha Scandinavia AB**  
J. A. Wettergrens Gata 1, Box 30053  
S-400 43 Göteborg, Sweden  
Tel: 031 89 34 00

### DENMARK

**YS Copenhagen Liaison Office**  
Generatorvej 6A, DK-2730 Herlev, Denmark  
Tel: 44 92 49 00

### NORWAY

**Norsk filial av Yamaha Scandinavia AB**  
Grini Næringspark 1, N-1345 Østerås, Norway  
Tel: 67 16 77 70

### RUSSIA

**Yamaha Music (Russia)**  
Room 37, bld. 7, Kievskaya street, Moscow,  
121059, Russia  
Tel: 495 626 5005

### OTHER EUROPEAN COUNTRIES

**Yamaha Music Europe GmbH**  
Siemensstraße 22-34, 25462 Rellingen, Germany  
Tel: +49-4101-3030

## AFRICA

**Yamaha Corporation,  
Asia-Pacific Sales & Marketing Group**  
Nakazawa-cho 10-1, Naka-ku, Hamamatsu,  
Japan 430-8650  
Tel: +81-53-460-2303

## MIDDLE EAST

### TURKEY/CYPRUS

**Yamaha Music Europe GmbH**  
Siemensstraße 22-34, 25462 Rellingen, Germany  
Tel: 04101-3030

### OTHER COUNTRIES

**Yamaha Music Gulf FZE**  
LOB 16-513, P.O.Box 17328, Jubel Ali,  
Dubai, United Arab Emirates  
Tel: +971-4-881-5868

## ASIA

### THE PEOPLE'S REPUBLIC OF CHINA

**Yamaha Music & Electronics (China) Co.,Ltd.**  
2F, Yunhedasha, 1818 Xinzha-lu, Jingan-qu,  
Shanghai, China  
Tel: 021-6247-2211

### INDIA

**Yamaha Music India Pvt. Ltd.**  
5F Ambience Corporate Tower Ambience Mall Complex  
Ambience Island, NH-8, Gurgaon-122001, Haryana, India  
Tel: 0124-466-5551

### INDONESIA

**PT. Yamaha Musik Indonesia (Distributor)  
PT. Nusantik**  
Gedung Yamaha Music Center, Jalan Jend. Gatot  
Subroto Kav. 4, Jakarta 12930, Indonesia  
Tel: 021-520-2577

### KOREA

**Yamaha Music Korea Ltd.**  
8F, 9F, Dongsung Bldg. 158-9 Samsung-Dong,  
Kangnam-Gu, Seoul, Korea  
Tel: 02-3467-3300

### MALAYSIA

**Yamaha Music (Malaysia) Sdn., Bhd.**  
Lot 8, Jalan Perbandaran, 47301 Kelana Jaya,  
Petaling Jaya, Selangor, Malaysia  
Tel: 03-78030900

### SINGAPORE

**Yamaha Music (Asia) Pte., Ltd.**  
#03-11 A-Z Building  
140 Paya Lebor Road, Singapore 409015  
Tel: 6747-4374

### TAIWAN

**Yamaha KHS Music Co., Ltd.**  
3F, #6, Sec.2, Nan Jing E. Rd. Taipei.  
Taiwan 104, R.O.C.  
Tel: 02-2511-8688

### THAILAND

**Siam Music Yamaha Co., Ltd.**  
4, 6, 15 and 16<sup>th</sup> floor, Siam Motors Building,  
891/1 Rama 1 Road, Wangmai,  
Pathumwan, Bangkok 10330, Thailand  
Tel: 02-215-2622

### OTHER ASIAN COUNTRIES

**Yamaha Corporation,  
Asia-Pacific Sales & Marketing Group**  
Nakazawa-cho 10-1, Naka-ku, Hamamatsu,  
Japan 430-8650  
Tel: +81-53-460-2303

## OCEANIA

### AUSTRALIA

**Yamaha Music Australia Pty. Ltd.**  
Level 1, 99 Queensbridge Street, Southbank,  
Victoria 3006, Australia  
Tel: 3-9693-5111

### COUNTRIES AND TRUST TERRITORIES IN PACIFIC OCEAN

**Yamaha Corporation,  
Asia-Pacific Sales & Marketing Group**  
Nakazawa-cho 10-1, Naka-ku, Hamamatsu,  
Japan 430-8650  
Tel: +81-53-460-2303

### HEAD OFFICE

**Yamaha Corporation, Pro Audio Division**  
Nakazawa-cho 10-1, Naka-ku, Hamamatsu, Japan 430-8650  
Tel: +81-53-460-2441

Yamaha Pro Audio Global Web Site  
<http://www.yamahaproaudio.com/>  
Yamaha Manual Library  
<http://www.yamaha.co.jp/manual/>