



User Guide



USB AUDIO INTERFACE

URX44V

URX44 URX22

Contents

Introduction	8
Product description	8
How the manuals are organized	9
Accessories	10
Notations used in this guide	11
Note	12
About the software	13
Controls and functions	14
Top panel	14
Rear panel	15
Front panel	18
Side panel (URX44V)	19
Getting ready	20
Installing TOOLS for MGX/URX	20
Connecting the power supply (URX44V)	21
Connecting the power supply (URX44, URX22)	23
Turning the power on/off	24
Connecting to your computer	25
Updating the firmware	26
Making connections	27
Connecting to an analog input/output	27
Connecting to your computer (Windows)	29
Connecting to your computer (Mac)	30
Connecting to a mobile device	31
Connecting video devices (URX44V)	33
Settings for video input to a computer (URX44V)	34

Overview of the screen and basic operations 35

Overview of the screen 35

Basic screen operations 36

Operation mode 40

Operation mode settings 40

Simple mode 42

Standard mode 43

HOME screen (Overview) 44

Screen layout 44

Toolbar 45

Main area 46

 Channel view 46

 Channel area 48

Side menu 50

SETUP screen 51

Top menu 51

 GENERAL menu 51

 Version menu 52

 License menu 53

 Language menu 54

 Brightness menu 55

 User Defined Knobs menu 56

 Sampling Frequency menu 57

 Output Patch menu 58

 Peripheral menu 60

 Power Management menu 62

 Date/Time menu (URX44V, URX44) 63

 Software Integration menu (V1.2 and later) 64

MONITOR screen 65

Top menu 65

Monitor menu 66

Phones menu	68
Oscillator menu	69
SCENE screen	71
<hr/>	
Top menu	71
Scene List menu	72
microSD screen (URX44V, URX44)	75
<hr/>	
Top menu	75
USB Storage Mode button (V1.2 and later)	77
RECORDER menu	78
TOOLS menu	83
Channel view	86
<hr/>	
Screen layout	86
Toolbar	87
Channel settings screen	88
Main area	90
Dedicated channel screen	95
<hr/>	
Channel settings screen	95
INPUT screen	96
GATE screen	99
COMP screen	100
EQ screen	102
SSMCS (Sweet Spot Morphing Channel Strip) screen	104
Main screen	104
COMP screen	106
COMP Side Chain screen	107
EQ screen	108
INS FX screen	109
DUCKER screen	110
DELAY screen	111

SEND TO screen	112
Simple mode operation guide	114
<hr/>	
How to access simple mode	114
Selecting the presets and use cases	117
Selection menu screen	117
“Live music, event” overview	118
“Streaming” overview	119
“DAW recording” overview	120
Simple mode screens	121
HOME (Overview) screen layout	121
Toolbar	122
Input area	123
Mix selection and output area	125
Example of parameter operation: “Streaming” use case	127
Channel view screen	128
Sound-related operations	130
<hr/>	
Operating the gate from the HOME screen (Overview)	130
Operating the compressor from the HOME screen (Overview)	131
Operating the gain from the HOME screen (Overview)	132
Operating the EQ from the HOME screen (Overview)	133
Operating the insert from the HOME screen (Overview)	134
Operating the SSMCS from the HOME screen (Overview)	135
Operating the ducker from the HOME screen (Overview)	136
Operating the delay from the HOME screen (Overview)	137
SEND TO settings	138
Other operations	139
<hr/>	
Storing a scene	139
Recalling a scene	140
Deleting a scene	141
Changing the scene title	142
Recording to a microSD card (URX44V, URX44)	143

Playing back audio recorded on a microSD card (URX44V, URX44)	144
Using the monitor function	145
Using the PHONES	146
Using the oscillator	147
Using the cue function	148
Assigning functions to the user defined knobs	149
Updating the firmware	151

Using the Software Integration functions (V1.2 and later) 153

Getting ready (DAW Integration)	153
Steps for configuring DAW Integration	154
Using in tandem with a DAW	156
Dedicated screens for the Cubase Series	156
How to open the screens	157
Input settings screen	158
Hardware settings screen	161
MixKey channel editor	162
How to open the screens	163

Restoring the factory settings 165

Initializing this unit	165
-------------------------------------	------------

Mounting the unit on a panel or stand 166

Installing the interface unit	166
--	------------

Frequently asked questions 167

Troubleshooting (audio)	167
No sound is heard	167
Sound is distorted	169
Troubleshooting (power supply)	170
Troubleshooting (other issues)	171

Appendix	172
Trademarks	172
General specifications	173
Technical specifications	175
Effect list	180
Functions that can be assigned to the user defined knobs	182
USB MAIN signal name reference table	183
Dimensions	185
Block diagram	186

Introduction

Product description

URX series USB audio interfaces feature a newly designed microphone amplifier and professional grade AD/DA converter that offer the highest 32-bit and 192 kHz support available in their class.

With the widest dynamic range and the highest level of audio performance befitting the top-of-the-line products in the series, these audio interfaces fully capture every nuance and expression present in the audio source.

Recording, production, performance and streaming, all in one unit

The URX Series offers both powerful and flexible connection and routing options that cover your needs from music production to online streaming in one unit. Two USB ports (MAIN and SUB) are available for collecting audio signals from two devices such as a computer or smartphone, or for creating a system for recording to a sub device and for streaming.

The URX44 and URX44V feature four mic preamps, along with functionality for multitrack recording to an SD card. This URX44V also features video signal capture functions and HDMI pass-through. With just this unit, you can create a production and streaming system that lets you create backup recordings as well as process video signals.

Rapid and intuitive—a dual interface with both touch and physical controls

The touch LCD panel and various physical control knobs on the URX Series give you intuitive and rapid control with a seamless workflow, without getting in the way of your creativity.

Built-in DSP for a more polished sound and a stronger performance

This series features a built-in custom DSP chip (the SSP3) to offer professional sound quality that adds the finishing touch to your sound in any scene, from recording to music production to livestreaming. This unit also offers the ideal latency characteristics along with a high-definition monitoring environment for live and streamed performances.

Trusted solutions brought to you by Yamaha and Steinberg

Yamaha and Steinberg bring together the technologies and strengths they have created through their respective expertise in hardware and software, offering solutions that support the creative activities of users through collaboration between established industry brands and software such as Elgato and OBS Studio.

How the manuals are organized

The manuals that cover this product are listed below.

Printed manuals

- Safety Guide (included)
Contains the information necessary for you to safely use this product. Make sure to read this before use.
- Start Guide (included)
Explains the operations you must do first after purchasing this product.

Online manuals

- Setup Guide
Explains the steps to take for getting ready to use this product, and how to download the bundled software. Access this guide by opening the "Getting Started" file in the USB drive of this unit, or by clicking the following link.
https://manual.yamaha.com/audio/music_audio_production/urx44_urx22/sp/
- User Guide (this guide)
Explains all of the functions of this product.
- Effect Reference Guide
Explains the effect parameters in detail. Access this guide from the following link.
https://manual.yamaha.com/audio/music_audio_production/effect_rg/

Please keep the included manuals in a safe place where you can easily access them at any time. You can download these manuals from the Yamaha website. Use this information as necessary.

<https://download.yamaha.com/>

Accessories

This product includes the following accessories. Check whether all of these items have been properly packaged with the product.

URX44V

- USB-C to USB-C cable (USB 3.2, 1 m long) × 1
- Power adapter (including power cord) × 1
- Ferrite core × 1
- Start Guide × 1
- Safety Guide × 1
- Cubase AI License Card × 1
- Basic FX Suite License Card × 1
- Steinberg Plus License Card × 1

URX44, URX22

- USB-C to USB-C cable (USB 2.0, 1.5 m long) × 1
- Start Guide × 1
- Safety Guide × 1
- Cubase AI License Card × 1
- Basic FX Suite License Card × 1
- Steinberg Plus License Card × 1

Notations used in this guide

- In this guide, the names of controls on the control panel as well as the virtual buttons and knobs shown on the screen are indicated within square brackets. The section name may be written in front of the brackets for some controls (example: USER DEFINED KNOBS [1] knobs).
- If the specifications in the text differ for different models, the applicable models are indicated in parentheses (example: [MIC/LINE INPUT 1 to 4] connectors (URX44V, URX44) or [MIC/LINE INPUT 1, 2] connectors (URX22)).
- In this document, “URX Series” is used when referring to all models.
- Unless specified otherwise, illustrations in this guide show the URX44V model.

Note

■ Data copyrights

- The software and this guide may not be reproduced or modified, in whole or in part without permission.
- Except as permitted by copyright laws and other relevant laws, it is prohibited to reproduce or transfer third-party contents (commercially available music, sound data, video, etc.) without the permission of the copyright holder.

■ Protection of copyright

- Do not use this product for any purpose that may infringe upon the rights of any third party, including copyrights, as established by law in each country or region.
- Yamaha bears no responsibility for any infringement upon third party rights that may occur as a result of using this product.

■ Notice regarding the contents of this guide

- The precautions and other matters in this guide are classified as follows.



• **WARNING**

This content indicates “risk of serious injury or death.”



• **CAUTION**

This content indicates “risk of injury.”

• **NOTICE**

Indicates points that you must observe in order to prevent product failure, damage or malfunction and data loss, as well as to protect the environment.

• **NOTE**

Indicates notes on instructions, restrictions on functions, and additional information that may be helpful.

- All illustrations and screens shown in this guide are for explanatory purposes.

About the software

Various bundled software is included with the URX Series.

Refer to the Setup Guide for details on each software title.

To access the Setup Guide, open the “Getting Started” file in the USB drive of this unit, or click the following link.

https://manual.yamaha.com/audio/music_audio_production/urx44_urx22/sp/

Controls and functions

Top panel

NOTE

The URX44V is shown in the illustration. The actual number of input/output connectors depends on the model.



1 Display

This is a color LCD screen that features an electrostatic touch panel. The panel will not operate correctly if you are wearing gloves or other hand coverings.

NOTICE

- Do not use a sharp object or hard objects such as your fingernails to operate the screen. Doing so may scratch the screen or cause the touch panel to stop working.

NOTE

Remove the transparent protective film that was applied to the display prior to shipment from the factory.

2 Multi-function knobs

These knobs control four of the main parameters shown on the display.

3 [TOUCH AND TURN] knob

Operates the parameter you select on the display.

4 [⏻] (power) switch (p.24)

Switches the power on/off. This lights up when the power is on.

Rear panel

URX44V

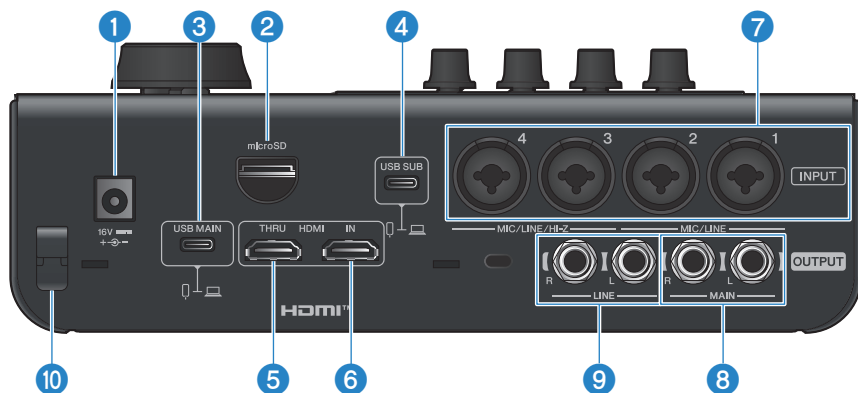

URX44 and URX22 (The actual number of input/output connectors depends on the model.)

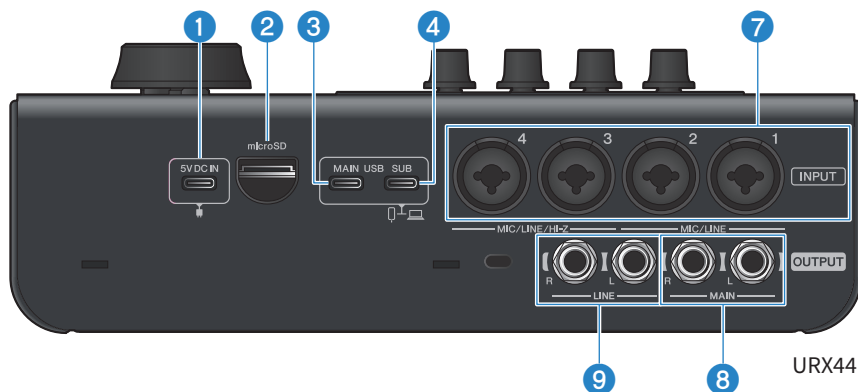

1 [16V] DC IN connector (URX44V)

Connect the included power adapter here.

[5V DC IN] connector (URX44, URX22)

Used to a commercially available USB-C power adapter, USB mobile battery, or other such device. Use it if the computer cannot supply sufficient bus power.

NOTE

- Use a USB cable with a USB-C plug to connect to this port.
- Use a USB power adapter or USB mobile battery with an output of 5 V DC (3 A or more).

2 [microSD] slot (URX44V, URX44)

Use this slot to insert a microSD card.

3 [USB MAIN] connector (USB-C™)

URX44V

Connect the USB cable included with the computer or other device.

Use this to send/receive 18 in/18 out, 44.1 kHz to 192 kHz 32-bit audio signals, or to send video signals input via the [HDMI IN] connector.

URX44, URX22

Connect the USB cable included with the computer or other device. To operate the device using bus power, connect it to a computer with a 5 V DC (3 A or more) output.

Use it to send/receive 18 in/18 out (URX44), 16 in/16 out (URX22), 44.1 kHz to 192 kHz 32-bit audio signals.

NOTE

- If the computer USB port is a USB-A type port, connect a commercially available USB-A to USB-C cable.
- If connecting to an iPad, iPhone, or other mobile device, connect a direct USB-C to USB-C cable to a USB-C port.

Observe the following precautions in order to avoid device failure or data loss.

NOTICE

- The URX44V model does not support using USB bus power.
- Do not connect any devices besides a computer, iPhone or iPad.
- When connecting to a computer, perform the following steps to prevent data loss in the event that the computer or this product stops (hangs up).
 - Be sure to use the included USB cable.
 - Before plugging in or unplugging a USB cable, make sure to quit all applications.
 - Before plugging a cable into the [USB MAIN] port, turn off the [⏻] (power) switch or turn the volume all the way down.
 - Wait at least six seconds between turning this product's power on/off or plugging in/unplugging a USB cable.
 - If your computer or this product hangs up, restart the application or your computer, or turn this product off and on again.

4 [USB SUB] connector (USB-C)

Use a commercially available USB cable (USB 2.0 or higher) to connect this to a USB port on the computer or mobile device. Use it to send/receive 2 in/2 out, 48 kHz, or 24-bit audio signals.

When using a mobile device such as an iPad, iPhone or Android device, directly connect the USB-C port of your device with a USB-C to USB-C cable to the USB-C port. Use a suitable adapter to connect devices without a USB-C port.

NOTICE

- USB bus power is not supported.
- Use a USB cable less than 3 meters long.
- Do not connect any devices other than a computer, a mobile device such as an iPad, iPhone or Android device, or a console gaming device.
- Perform the following precautions to prevent data loss in the event the device stops functioning (becomes hung).
 - Before plugging in or unplugging a USB cable, make sure to quit all applications.
 - Before plugging a cable into the [USB SUB] port, turn off the [⏻] (power) switch or turn the volume all the way down.
 - Wait at least six seconds between turning this product's power on/off or plugging in/unplugging a USB cable.
 - If the device stops functioning, restart the application or device, or turn the interface unit power supply off and on.

5 [HDMI THRU] port (URX44V)

Connect the HDMI input connector of your monitor display or similar device here with an HDMI cable.

6 [HDMI IN] port (URX44V)

Connect the HDMI output connector of your camera, Blu-ray player, console game or other device here with an HDMI cable.

7 [MIC/LINE INPUT ports 1 to 4] (URX44V, URX44)

[MIC/LINE INPUT ports 1 and 2] (URX22)

Connect your mics and musical instruments here. These are combo connectors compatible with both XLR-type and TRS phone plugs. The [MIC/LINE INPUT 3, 4] connectors on the URX44V and URX44 support HI-Z.

The [MIC/LINE INPUT 2] connector on the URX22 supports HI-Z.

If a mic is connected to the [HEADSET] connector, the signal from [MIC/LINE INPUT connector 1] is not input.

Connect instruments with high output impedance, such electric guitars or electric basses, to a connector that supports HI-Z. Connect them using an unbalanced phone-type cable. After connecting the instrument, switch on the HI-Z button for the corresponding channel shown on the Input Setting screen (p.96).

8 [OUTPUT MAIN] connectors

These TRS phone connectors are for connecting devices such as powered monitor speakers.

9 [OUTPUT LINE] connector (URX44V, URX44)

These TRS phone connectors are for connecting devices such as powered monitor speakers.

10 Cord hook (URX44V)

This hook is for attaching the power adapter cord. This makes it more difficult to accidentally pull out the plug.

Front panel

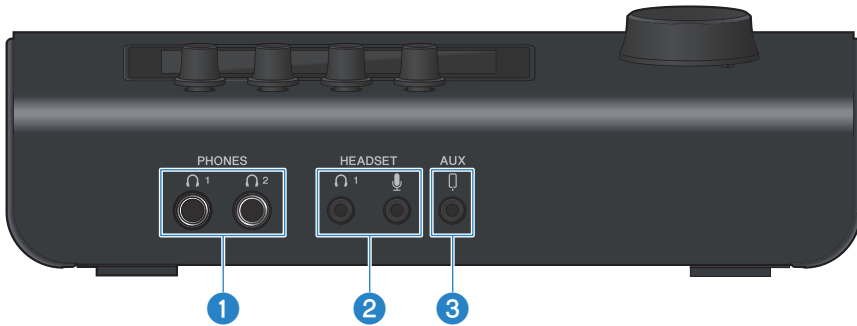

1 [PHONES 1 and 2] connectors

Connect your headphones to these TRS phone connectors. If a headphones connector is connected to the [HEADSET] connector, the audio sound from [PHONES 1] is muted.

2 [HEADSET] connectors

This headphones connector and mic connector are used to connect a headset. If a headphones connector is connected to the [HEADSET] connector, the audio sound from [PHONES 1] is muted.

Similarly, if a mic is connected to the [HEADSET] connector, the audio signal from the [MIC/LINE INPUT connector 1] on the rear panel is not input.

3 [AUX] connectors

This is used to connect a smartphone or other external device (3.5 mm, three-pin mini-plug).

Side panel (URX44V)

Ventilation ports

The URX44V is equipped with a cooling fan. The fan starts rotating automatically if the temperature inside the interface unit becomes too high. This blows air out of the unit, so make sure that nothing is blocking the air flow from the ventilation ports.



CAUTION

- Do not block the ventilation ports (heat dissipating slits) of this product. This unit features ventilation ports on the side to prevent the inside from getting too hot. If the ventilation ports are covered, heat gets trapped inside the product, which may result in malfunction and/or fire.

Getting ready

Installing TOOLS for MGX/URX

TOOLS for MGX/URX is a software package that's necessary for connecting and using this product with your computer. Follow the steps below to install TOOLS for MGX/URX on your computer.

1 Access the following website to download TOOLS for MGX/URX.

<https://www.yamaha.com/2/urx/>

2 Decompress (extract) the downloaded file.

3 Launch TOOLS for MGX/URX Installer.

4 Follow the onscreen instructions to install the software.

This completes the installation of TOOLS for MGX/URX.

Connecting the power supply (URX44V)

Connect the included power adapter to the [16V] DC IN connector port on the rear panel of the unit in the order shown below.

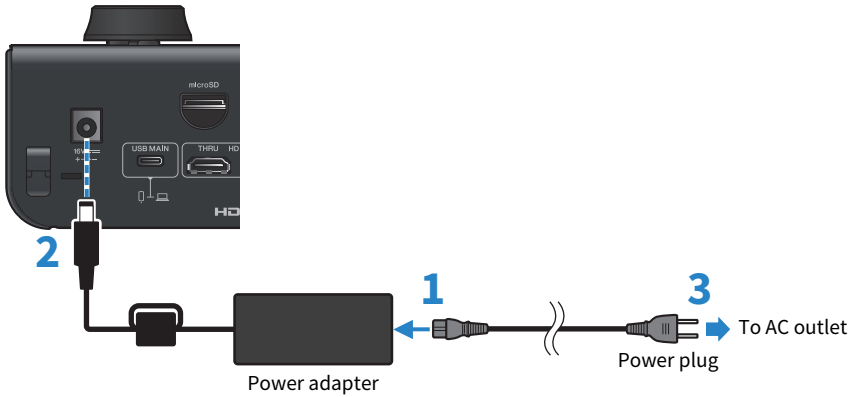

NOTE

- When unplugging the power adapter or power cord, turn off the power and perform the steps in reverse.
- The power plug may be shaped differently depending on the country or region.
- Attaching the power adapter cord to the hook makes it more difficult to accidentally pull out the plug.



WARNING

- Make sure to use the power adapter and power cord that were included with this unit. Using a different power adapter or power cord may result in product failure, overheating, fire or other issues.
- Place the unit close to the AC outlet. If anything unusual is noticed, immediately turn off the power and unplug the power cord from the AC outlet.

NOTICE

- A small amount of power flows even when this unit is off. When this product will not be used for a long time, be sure to unplug the power adapter from the outlet.
- Do not wrap the power adapter cord tightly while it is attached to the hook, or pull on the cord. This may cause wear and tear on the cord's surface, or damage the hook.

■ Precautions regarding the placement of the power adapter

Position the DC power cord at least 10 cm away from the power adapter unit, as shown below. Not keeping the cord at least 10 cm away from the adapter could cause a malfunction or a temporary performance drop in surrounding equipment due to electromagnetic waves emitted by the power adapter.

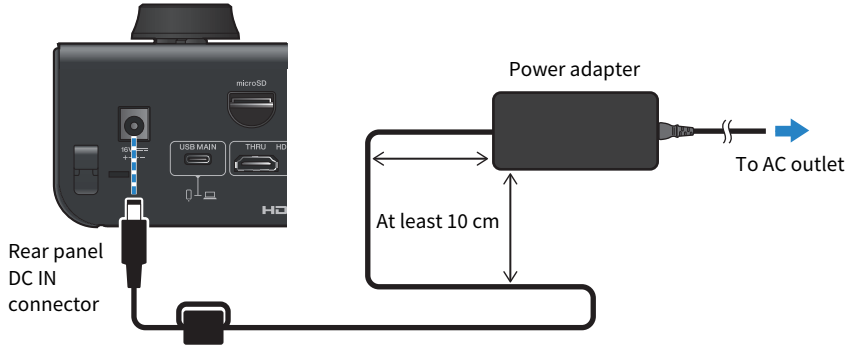

Connecting the power supply (URX44, URX22)

Use the included USB cable to connect the [USB MAIN] port on main unit to the USB-C port on the computer. If the computer cannot supply sufficient bus power, connect a commercially available USB power supply adapter or a USB mobile battery to the [5V DC IN] connector on the main unit.

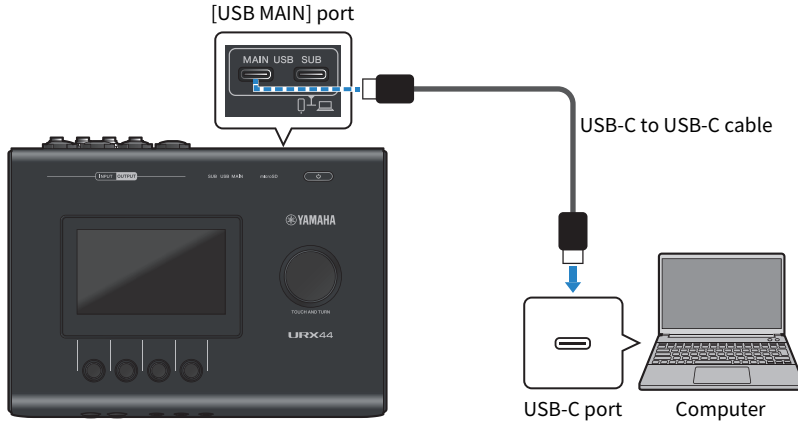

NOTE

- Use a commercial USB power supply adapter or a USB mobile battery with an output of 5 V DC (3 A or more).
- If the computer USB port is a USB-A type port, connect a commercially available USB-A to USB-C cable. In that case, a commercially available USB power adapter or USB mobile battery must be connected to the [5V DC IN] connector on the main unit.

Turning the power on/off



WARNING

- Before turning the power on or off, be sure to turn the volume settings all the way down on the interface unit and other connected devices. Failure to do so may cause hearing loss, electric shock or equipment damage.

Power on

Press the [⏻] (power) switch on the top panel. The [⏻] (power) switch lights up.

NOTE

When you turn on this product for the first time, a screen will appear, prompting you to set the language, date and time, and operation mode (p.40). Follow the onscreen instructions.

Power off

Long-press the [⏻] (power) switch on the top panel. When you follow the instructions on the display and select [OK], the [⏻] (power) switch goes dark.

Note

If no operations are performed with the power on during the past specified length of time, the auto power off function will automatically turn off the power (p.62). For the URX44V model, the auto power off function is enabled in default settings.

NOTICE

- Repeatedly toggling the [⏻] (power) switch on/off in rapid succession may cause a malfunction.
- Wait at least six seconds after turning off the [⏻] (power) switch before turning it back on.
- To turn off the power, make sure to hold down the [⏻] (power) switch on the top panel, and follow the instructions on the display.
- If the power is directly interrupted, such as by unplugging the power adapter or USB cable, it could cause the data backup to fail or damage the microSD card file system.

Connecting to your computer

- 1 Use the included USB cable to connect the USB MAIN port on the rear panel to a USB-C port on the computer.

URX44V

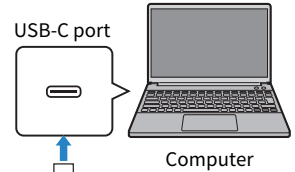
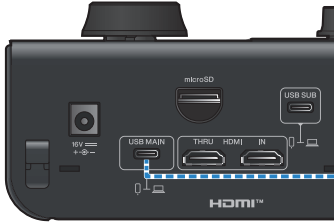

USB-C to USB-C cable

URX44, URX22



NOTE

If the computer USB port is a USB-A type port, connect a commercially available USB-A to USB-C cable. In that case, a commercially available USB power adapter or USB mobile battery must be connected to the [5V DC IN] connector on the main unit.

- 2 Press the [⏻] (power) switch on the top panel to turn the power on.



WARNING

- Be sure to turn the device's volume all the way down before turning on the power. Failure to do so may cause hearing loss, electric shock or equipment damage.

- 3 If using a USB audio device, configure the "Sound" (Windows) or "Audio device" (Mac) setting in the computer (see p.29 or p.30).

Updating the firmware

The firmware of this product is designed to be updated for improved operability, added functionality and to correct problems.

Make sure to update the firmware to the latest version to ensure optimum use of all the features of this product.

Refer to “p.151” in “Other operations” for how to update the firmware.

Making connections

Connecting to an analog input/output

■ Example of connecting to an analog input

Connect a mic, electronic musical instrument, audio device or other line-level equipment to the INPUT connectors.

The [MIC/LINE INPUT 3, 4] connectors on URX44V and URX44 models, and [MIC/LINE INPUT 2] connector on the URX22 model supports HI-Z.

Connect instruments with high output impedance, such as electric guitars or electric basses, to a connector that supports HI-Z.

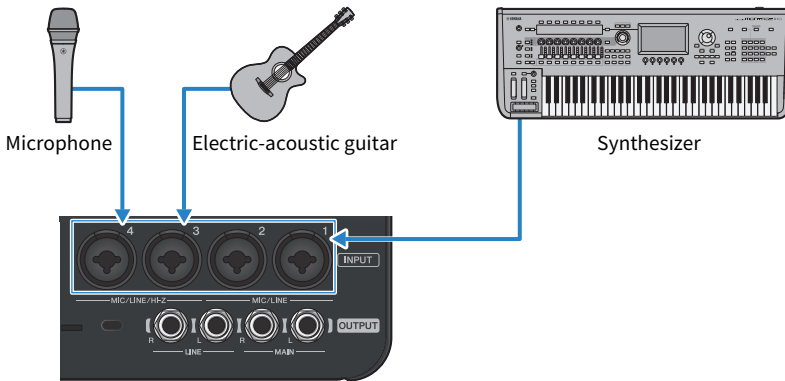

■ Example of connecting to an analog output

Connect speakers to the OUTPUT connectors.

Connect headphones to the PHONES connectors.

Making connections > Connecting to an analog input/output

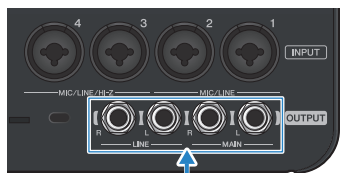

Monitor speakers



Headphones

Connecting to your computer (Windows)

When you first install “TOOLS for MGX/URX”, the “Yamaha Steinberg USB Driver” is automatically installed so that your computer can recognize this product. Download and install the “TOOLS for MGX/URX” from the following website.

<https://www.yamaha.com/2/urx/>

For computer connection instructions, refer to “Getting ready” → “Connecting your computer” (p.25).

NOTE

- The steps may differ depending on computer or OS settings are configured.
- For a list of compatible operating systems, see the Yamaha website listed above.

Settings on the computer

Change the computer output/input settings to “URX series.”

- 1 From the “Start” menu, open “Settings”.**
- 2 Select “System” → “Sound”.**
- 3 On the “Sound” screen, select A–C “Yamaha URX**” as the output/input device.**
Enter the model name (44V, 44, or 22) instead of the double-asterisks.
- 4 Close the “Sound” settings.**

About the signal names on the computer and this unit’s display

Refer to “USB MAIN signal name reference table” (p.183) regarding the signal names displayed by the computer’s sound/DAW apps or as the Input Source (input source) on the unit’s display.

Select the input source for each channel on the INPUT screen (p.96).

Connecting to your computer (Mac)

When you first install “TOOLS for MGX/URX”, the “Yamaha Steinberg USB Driver” is automatically installed so that your computer can recognize this product. Download and install the “TOOLS for MGX/URX” from the following website.

<https://www.yamaha.com/2/urx/>

For computer connection instructions, refer to “Getting ready” → “Connecting your computer” (p.25).

NOTE

- For a list of compatible operating systems, see the Yamaha website listed above.
- If using a Mac without a USB-C port, connect it using a commercially available USB-A to USB-C cable.

Settings on the computer

- 1 Open “Finder” → “Move” → “Application” → “Utilities” → “Audio_MIDI settings”.**
- 2 In the list on the left side of the Audio Devices screen, select Yamaha URX**, DAW, or Yamaha URX** A to C.**
Enter the model name (44V, 44, or 22) instead of the double-asterisks.
If the audio devices screen is not shown, select “Windows” → “Display audio device” from the menu to make it appear.
- 3 Click [▼] at the bottom left of the screen and select “Use this sound output device”.**

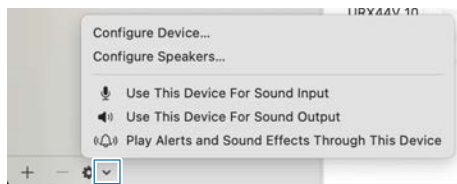

- 4 Similarly, select “Use this sound input device”.**
Once you’ve finished steps 3 and 4, the mic and speaker icons at the bottom right of [Yamaha URX**] in the list appear.
- 5 Quit “Audio_MIDI settings.”**

About the signal names on the computer and this unit’s display

Refer to the “USB MAIN signal name reference table” (p.183) for the names of signals shown on the computer’s sound/DAW app and on this unit’s display as the Input Source .

Select the input source for each channel on the INPUT screen (p.96).

Connecting to a mobile device

NOTE

For a list of compatible operating systems, see the following Yamaha website.

- <https://www.yamaha.com/2/urx/>

■ iPad, iPhone and Android devices with a USB-C port

What you need

- USB cable (included)

- 1 Use a commercially available USB-C to USB-C cable to connect iPad/iPhone devices to the [USB MAIN] or [USB SUB] port on the interface unit. Connect Android devices to the [USB SUB] port on the interface unit.**

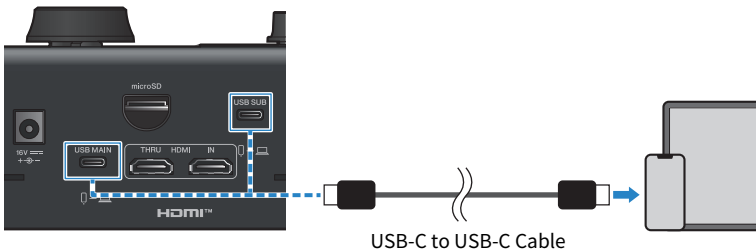

This product is automatically recognized by the iPad, iPhone or Android device once connected.

There is no need to configure any settings on the iPad, iPhone or Android device.

NOTE

If you will be streaming or using your device for long periods of time, we recommend supplying power to the device while it is in use. Use a USB-C Digital AV Multiport Adapter (commercially available) made by Apple for iPad/iPhone, or a commercially available audio conversion adapter that supports USB Power Delivery (USB PD) or the like for Android devices.

■ iPad/iPhone devices with a Lightning port

What you need

- Lightning to USB 3 Camera Adapter made by Apple (commercially available)
- USB-A to USB-C cable (commercially available)
 - URX44, URX22: USB 2.0 (High Speed) or greater
 - URX44V: USB 3.0 (Super Speed) supported

- 1 Use a commercially available USB-A to USB-C cable to connect the [USB MAIN] port or [USB SUB] port to an Apple brand Lightning to USB 3 Camera Adapter.**
- 2 Connect the Apple Lightning to USB 3 Camera Adapter made by Apple to the iPad/iPhone.**

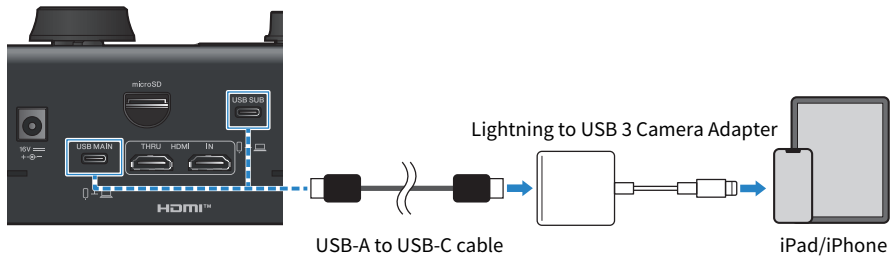

This product is automatically recognized by the iPad/iPhone once connected.

There is no need to configure any settings on the iPad/iPhone.

About the signal names on the iPad/iPhone and on this unit's display

For the signal names visible in the iPad/iPhone DAW app and signal names displayed as the Input Source on the interface unit display (input source), refer to “USB MAIN signal name reference table” (p.183). Select the input source for each channel on the INPUT screen (p.96).

Connecting video devices (URX44V)

■ Connection example

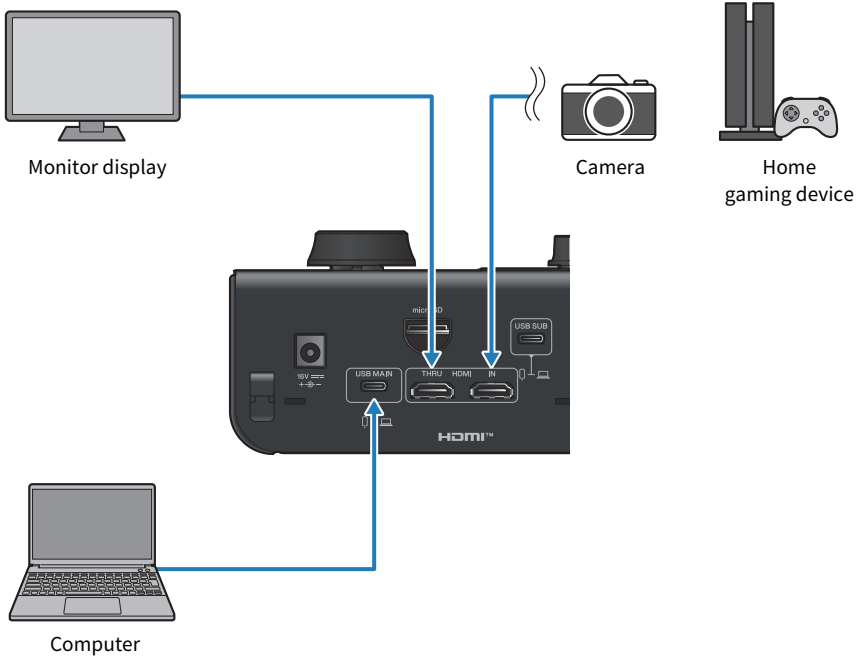

- The video signals that are input to the [HDMI IN] connector are passed directly through to the [HDMI THRU] connector as output. In addition, the format is converted to a UVC video signal and output from the [USB MAIN] connector.
- The audio signals input to the [HDMI IN] connector are down-mixed and added to the input channel as mixer input selection options. If two audio channels are selected in interface settings as HDMI inputs, then they are output directly to the [HDMI THRU] connector (p.60).
- Audio is not included in the video signal output to the computer. The audio needs to be included separately as USB audio. That requires selecting “HDMI” as a mixer input (p.96) and setting up a patch for USB MAIN (A, B, or C) in the Output Patch USB menu (p.58).

Settings for video input to a computer (URX44V)

Select [Yamaha MGX/URX Video] as the video input for your computer's application (app). There is no need to configure any settings on this product.

NOTE

- If the HDMI input is protected by HDCP, you will not be able to capture audio or video.
- If you are able to disable HDCP on your HDMI source device, you should disable it. You may also be able to resolve the problem by disabling HDCP on this product (p.60).

■ About HDMI

The URX44V supports HDMI signal inputs up to 4K/60 Hz (PCM 8 ch and 192 kHz/24-bit for audio).

- HDMI IN: Supports video up to 4K/60 Hz and audio up to 8 ch/192 kHz/24-bit. Note that the signal is down-mixed in this unit to 2 ch, and is resampled to match the sampling frequency of the unit.
- HDMI THRU: Passes through both video and audio. Note that if multi-channel audio is turned on as an HDMI input in interface settings, then audio is not output from the HDMI THRU connector.

NOTE

- The HDMI signal cannot be passed through while this product is in standby mode.
- This product does not support ARC/eARC.
- Use an HDMI cable (19-pin) that features the HDMI logo when connecting your devices. We recommend that you use a short cable to prevent signal quality degradation.

Overview of the screen and basic operations

Overview of the screen

The display screen on the top panel is mainly divided into four areas. Touch the screen to select, or use the knobs to make the corresponding detailed settings or access the function screens.



1 Toolbar

The icons let you access frequently used functions and system setting screens. The toolbar is always shown, even if you switch the main area display. (The number of icons changes depending on which screen is shown.)

2 Main area

Shows the contents that are appropriate for the screen or channel you select.

3 Side menu

Switches between menus that are shown in the main area.

4 Multi-function knob toggle button

Switches the USER DEFINED KNOBS mode on/off (p.36).

Basic screen operations

■ Direct operation by touch

Touch the icon buttons or menus on the toolbar to directly switch between screens.

NOTE

- On screens that are divided into multiple pages, touch the arrow buttons on either side to move between pages.

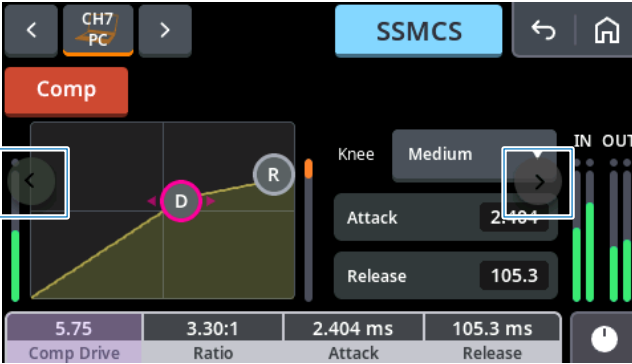

- The handles on the graph can be operated directly by touch.



■ [TOUCH AND TURN] knob

Touch the parameters on screen that you want to operate, and use the [TOUCH AND TURN] knob to quickly control them. A pink border appears around the parameter when you touch it.

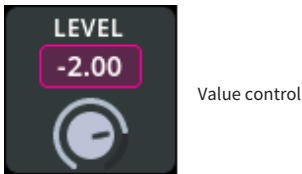

Press the knob during EQ operations to switch between Gain or Freq.

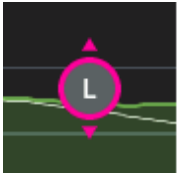

Direct control is possible

■ Operating with the multi-function knobs

The multi-function knobs let you directly operate four major parameters onscreen.

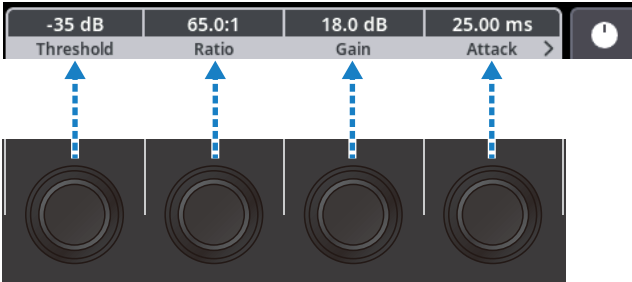

If many parameters are shown, touch [<] or [>] to switch between the target parameters.



When USER DEFINED KNOBS mode is on, you can control the value of the parameter you set. Touch [<] or [>] to switch between the four banks (1–4) of the USER DEFINED KNOBS. The selected bank number is outlined in the illustration below.



For the parameter settings in USER DEFINED KNOBS mode, see the [SETUP] screen → [top menu] → [User Defined Knobs] menu (p.56).

NOTE

The parameter you are controlling with the multi-function knobs is given focus in light purple.



■ **Onscreen user interface**

Buttons

Use the buttons to execute specific functions, toggle parameters on/off, and make selection from a list of options. The color of the buttons used for toggling on/off shows up more prominently when the button is on, and is fainter when the button is off.



Shows a separate popup screen for making detailed settings.



Shows a pull-down menu.



Returns to the previous screen.



Returns to the home screen.

If you touch this when on the HOME screen, this shows the channel view for the selected channel.

List screens

A screen like the one shown below appears when you select items from a list, such as the USER DEFINED KNOBS settings screen.

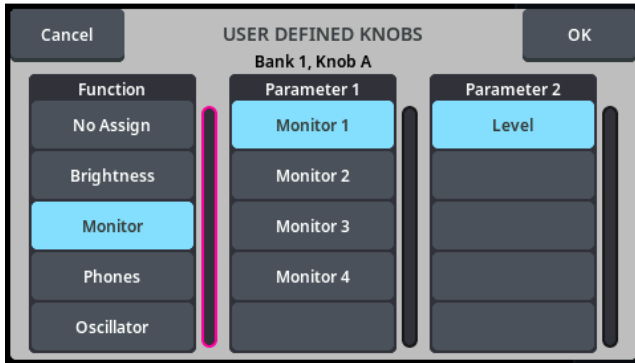

The items outlined in pink in the list are targeted (selected) for operation. Use the [TOUCH AND TURN] knob to scroll up and down within a list.

Dialog box

A dialog box like the one shown below appears when you need to confirm something about the operation you just executed. Touch [OK] to execute the operation. Touch [Cancel] to cancel the operation.

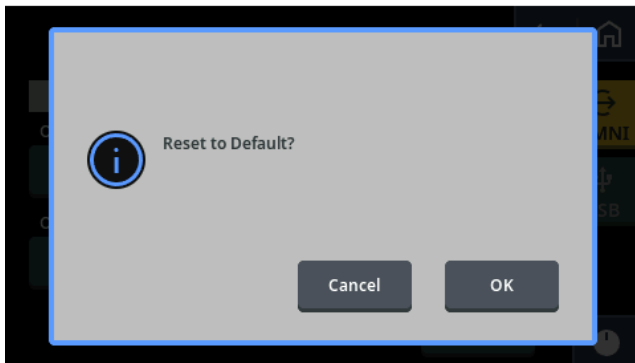

Scrolling

On screens with scroll bars, scrolling the screen up/down or left/right shows the following screen.

Operation mode

Operation mode settings

This product features two types of Operation Mode. For Simple Mode, available functionality is specified based on use cases prepared in advance. This mode lets you make settings by following along with the tutorial, operating the unit with a simple user interface. Standard Mode uses all of the functions.

NOTE

- When power is turned on for the first time, the Operation Mode screen is displayed after the Language Selection and Date/Time Setting screens. On the screen that's shown, choose either Simple Mode or Standard Mode.
- If you turn off the unit without selecting a mode, the Overview screen for Standard Mode is automatically shown the next time you turn on the unit.

■ How to set the operation mode

1 Touch [] in the toolbar to display the SETUP screen.

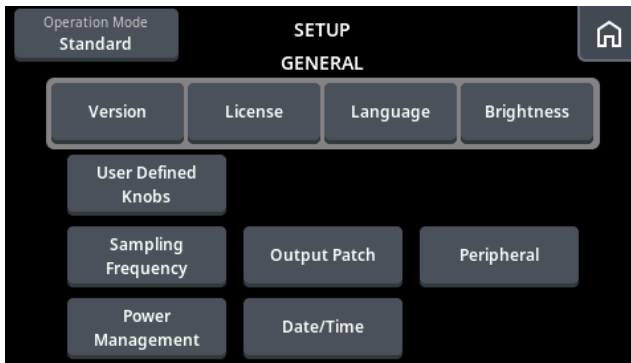

2 Touch [Operation Mode (Simple/Standard)] at the top left of the screen.

3 Select either “Simple Mode” or “Standard Mode”.



■ Settings when switching between operation modes

- **Simple Mode→Standard Mode**

The settings you make while operating in Simple Mode are carried over as-is to Standard Mode.

- **Standard Mode→Simple Mode**

The settings you make in Standard Mode are discarded and reinitialized for Simple Mode.

Simple mode

Simple Mode features functions that can be set easily, for settings that correspond to a variety of use cases. Simply follow the onscreen instructions of the setup assistant to select the operating mode and configure the necessary settings, for easy use of the URX series.

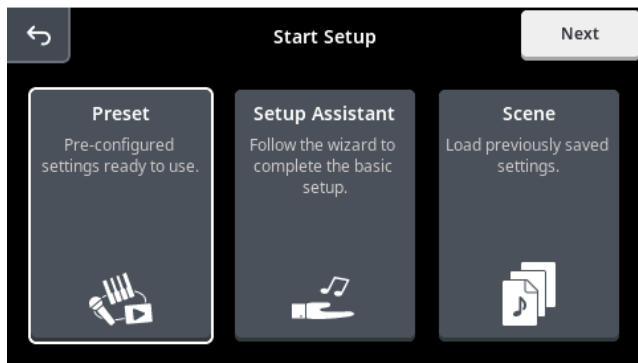

Automatic level adjustment function

Touch the [Auto] button to automatically adjust the input level. During adjustments, talk, sing, and play music at the actual volume to be used.

The input level will be set to the optimum setting once automatic adjustment is completed.

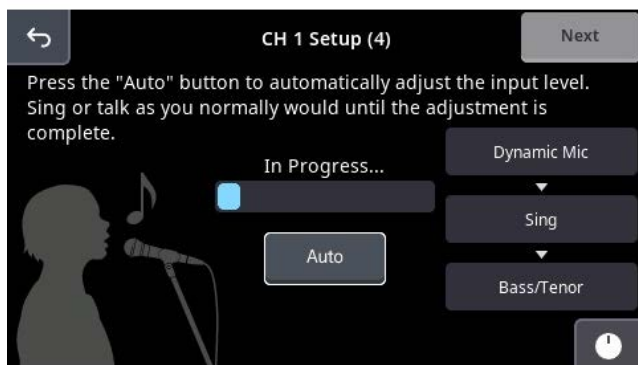

For details on Simple Mode, refer to the "How to access simple mode" (p.114).

Standard mode

Standard Mode lets you use all of the functions.

The screen layout in this guide and so forth are explained in Standard Mode (p.44).

See each section for details on the necessary operations.

HOME screen (Overview)

Screen layout

This is the main screen for this product in Standard Mode. This screen is shown when you start up this unit.

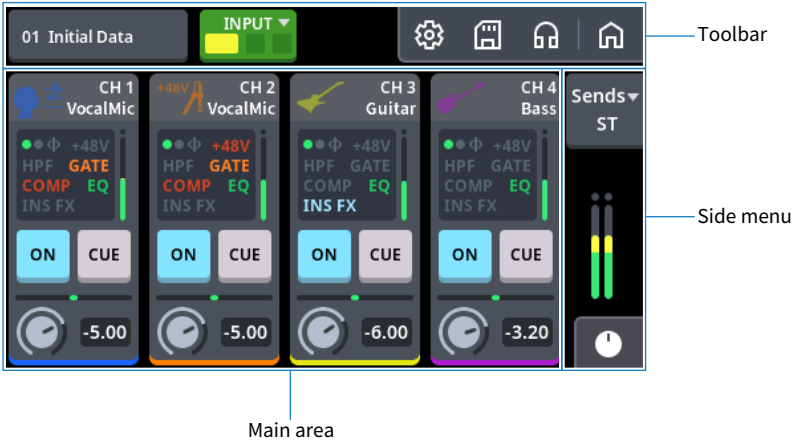

If a different screen is displayed, touching the  button on the toolbar will display this screen again.

When this screen is shown, touch the  button to show the channel view of the selected channel.



Toolbar



- 1 **Displays the [SCENE] screen (p.71).**
- 2 **Selects the channel bank to display in the main area (p.46).**
- 3 **Displays the [SETUP] screen (p.51).**
- 4 **Shows the [microSD] screen.  /  is displayed while playing back data from microSD (p.75).**
- 5 **Displays the [MONITOR] screen (p.65).**
- 6 **Displays the [HOME] screen (p.44).**

Main area

Channel view

Select the channel by touching the corresponding channel area in the main area. The selected channel is given focus with a white border. Touching the yellow border displays the channel view (p.86).



Channel bank

Four channels are shown at once in the main area. A group of channels shown at once is called a channel bank.

Switching between channel banks

You can switch between channel banks using the following methods.

- Touching the channel bank selection button on the toolbar
- Swiping left or right in the main area

NOTE

You can't switch between input and output channel banks by swiping left/right.

Channel view variations

 <p>MONO IN channel</p>	 <p>ST IN channel</p>	 <p>FX channel</p>
 <p>STEREO channel</p>	 <p>MIX channel</p>	 <p>STREAMING channel</p>

Channel display when used as a stereo pair (V1.2 and later)



When you select STEREO from Signal Type on the “Channel settings screen” (p.88), a heart symbol (♡) appears between the PAN slider for the odd- and even-numbered channels. The channel in question is the MONO IN channel.

Channel area

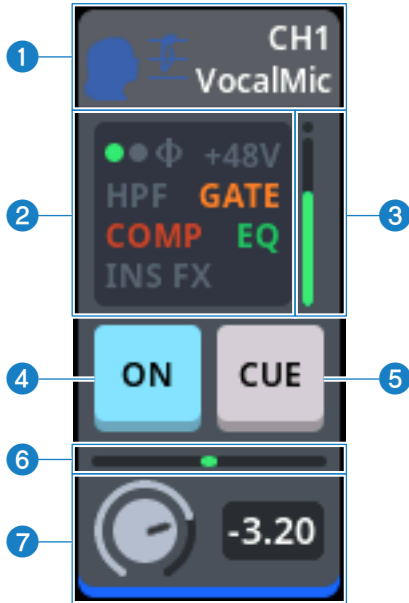

1 Channel name area

Shows the channel icon, channel ID and channel name.

NOTE

For ST IN channels, touching the channel name area switches between the channel (L/R) for which information is displayed in indicator area 2.



2 Channel indicator area

Shows the input signal level for the channel, as well as various settings. For details, refer to the “Dedicated channel screen” (p.95) section. When you tap this while a channel is selected, the channel view is shown.

3 Channel meter

This is a level indicator with a range of -60 dB to 0 dB. Stereo channels are shown with a stereo meter.

4 [ON] button

Toggles the channel on/off. This lights up when the channel is on.

HOME screen (Overview) > Main area

5 [CUE] button

Toggles CUE on/off for the channel. This lights up when CUE is on.

6 PAN/BALANCE slider

Shows either the PAN or the BALANCE setting for the channel.

7 Send level knob

This is operated by the multi-function knob below the display. You can adjust the send level by turning the knob.

NOTE

When USER DEFINED KNOBS mode is on for the multi-function knobs, the send level knob can't be operated.

Side menu

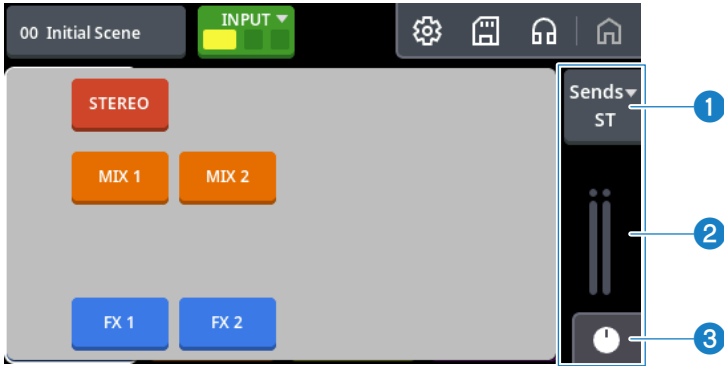

1 [Sends] button

Selects the send destination for the channel that's shown in the main area. The send destination selection menu is shown when you touch this button.

2 STEREO/CUE meter

Shows the post-fader level for the STEREO out channel. When CUE is on, the CUE bus level is shown. When you touch the meter area, all CUE turn off (CLEAR CUE function), and the display returns to the STEREO out channel view.



STEREO meter



CUE meter

3 Multi-function knob toggle button

Switches the USER DEFINED KNOBS mode on/off.



When USER DEFINED KNOB is off



When USER DEFINED KNOB is on

SETUP screen

Top menu

GENERAL menu

This is the top menu that's shown when you touch  in the toolbar. You can touch the respective buttons to access the version screen, license screen and the various settings screens.

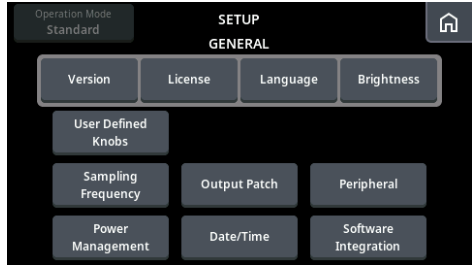
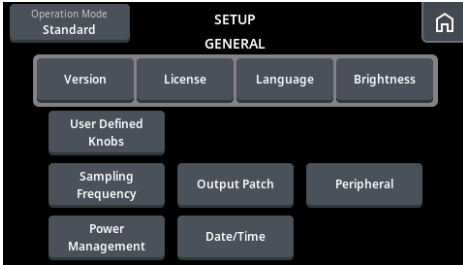

(V1.2 and later)

NOTE

There is no Date/Time menu on the URX22.

Version menu

Shows the version information for the system software.



License menu

Displays the LICENSE screen for showing system software license information. Use the [TOUCH AND TURN] knob to scroll the view.



Language menu

This lets you select the language that's displayed.

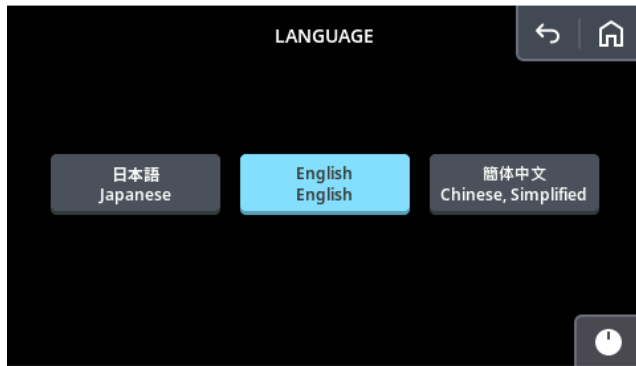

Brightness menu

This sets the display brightness level.

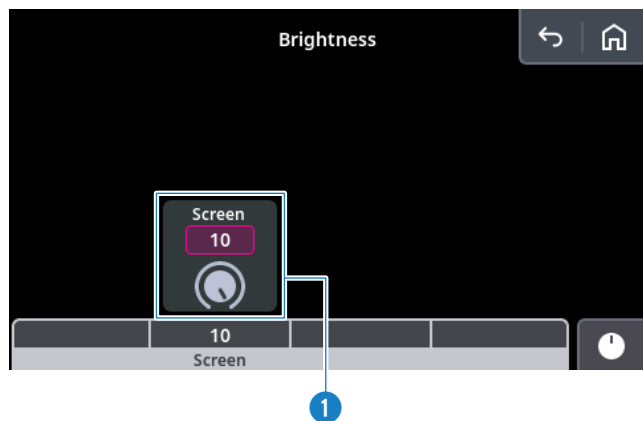

1 Screen

Sets the brightness for the display (LCD screen).

User Defined Knobs menu

This screen is for configuring the USER DEFINED knobs. Banks 1–4 are provided, and you can assign the functions you select to the A–D knobs.

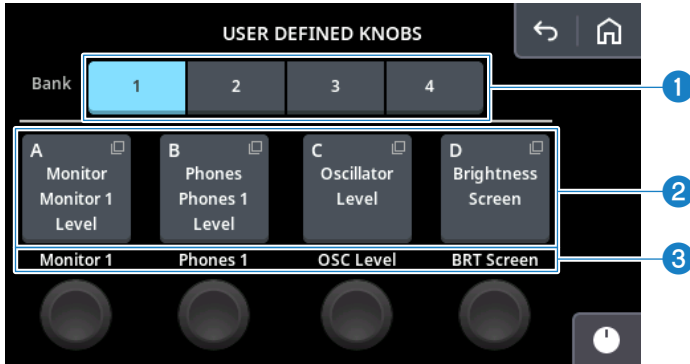

1 [Bank] 1–4

Selects the bank for which you will make the settings.

2 [USER DEFINED KNOBS] A–D

Shows the parameter that's set. The settings menu screen is shown when you touch these knobs.

3 [USER DEFINED KNOBS] display text

When the USER DEFINED KNOBS function is on, an abbreviated text label is shown at the lower part of the screen.

Sampling Frequency menu

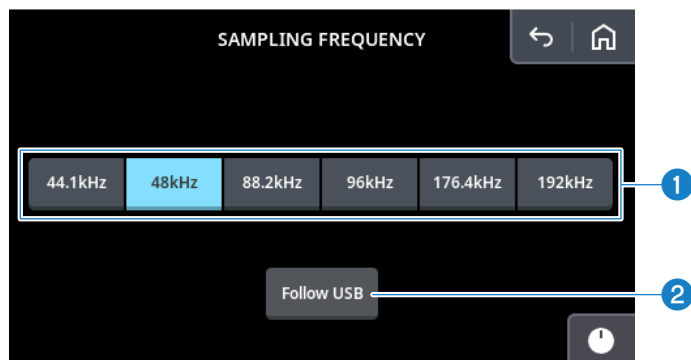

1 [44.1kHz, 48kHz, 88.2kHz, 96kHz, 176.4kHz, 192kHz] buttons

Use these buttons to select the sampling frequency for the mixer and the signal processing.

2 [Follow USB] button

When this is on, the sampling frequency setting matches that of the computer connected to the USB MAIN port.

Output Patch menu

■ ANALOG menu

This menu is used to configure the settings for the signals outputted from the OUTPUT output connector/port.

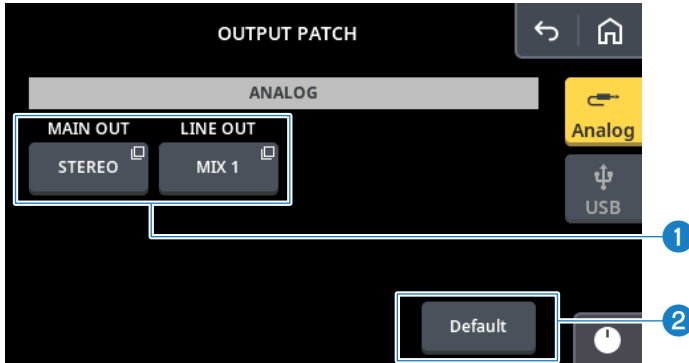

1 Output source selection buttons

The output source selection popup menu is shown when you touch these buttons. Select the source from the screen that's shown.

List of sources to select

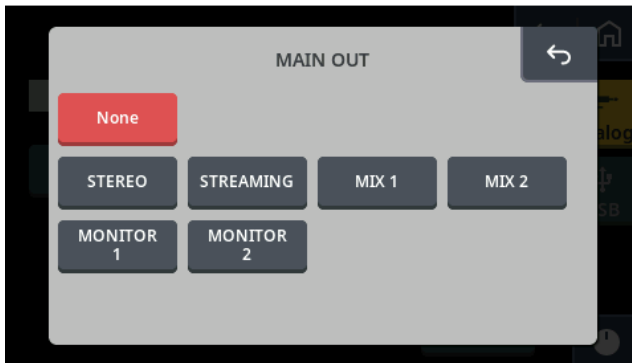

2 [Default] button

Resets the patch settings. When you touch this button and tap [OK] on the dialog box that's shown, the settings are reset.

■ USB menu

This menu is used to configure the settings for the signals outputted from the USB output connectors/ports.

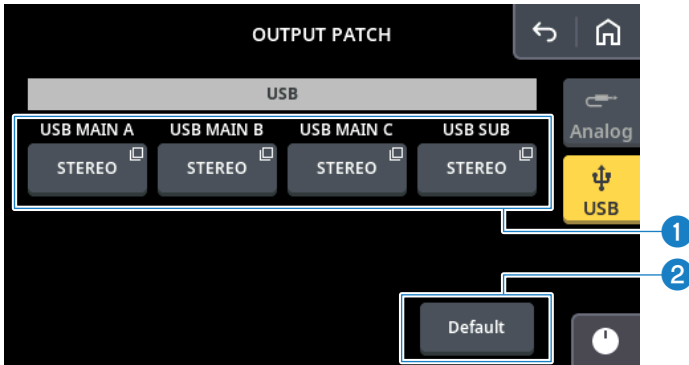

1 Output source selection buttons

The output source selection popup menu is shown when you touch these buttons. Select the source from the screen that's shown.

List of sources to select

URX44V, URX44



URX22



2 [Default] button

Resets the patch settings. When you touch this button and tap [OK] on the dialog box that's shown, the settings are reset.

NOTE

(URX44V)

For purposes of copyright protection, audio that is protected by HDCP cannot be output via USB. Select "HDMI" for the input source of either input channel to output the HDMI audio to all output channels. If the HDMI input signal is HDCP-protected, the audio sent to USB from these channels is automatically muted.

Peripheral menu

■ USB Main menu

This is for configuring the USB port settings.

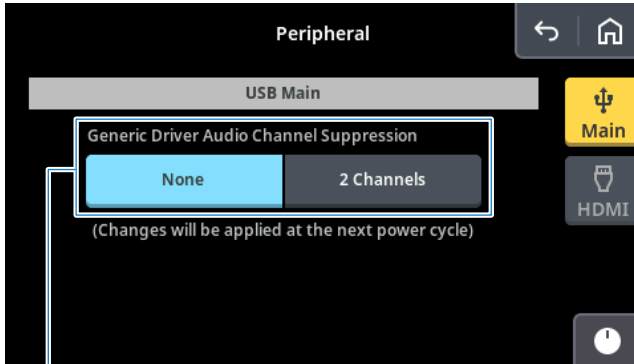

1 [Generic Driver Audio Channel Suppression]

This configures input/output channel restrictions when connecting using standard drivers on devices like the iPad/iPhone.

- [None]: no restriction
- [2 Channels]: The channels are restricted to 2 IN/2 OUT.

Select [2 Channels] when using this unit with apps that only support 2 IN/2 OUT audio streams.

■ HDMI menu (URX44V)

This is for configuring the HDMI settings.

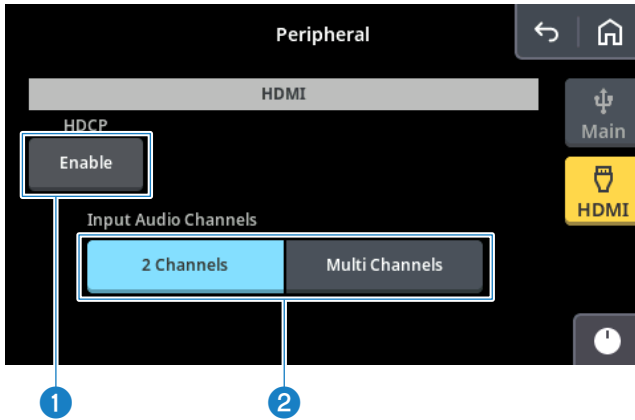

1 HDCP [Enable] button

Use this to enable/disable HDCP (High-bandwidth Digital Content Protection) on this product. HDCP is enabled when the button is on, and disabled when the button is off.

2 [Input Audio Channels]

Sets the number of HDMI audio input channels and the corresponding sampling frequency.

- [2 Channels]: always two channels (48 kHz max.)
- [Multi Channels]: supports up to 192 kHz/8 channels

The signals are down-mixed in the mixer to stereo (two channels), even when multi-channel input is used.

Power Management menu

■ Auto Power Off menu

This feature automatically turns off the power if the unit has not been operated for a specified length of time.

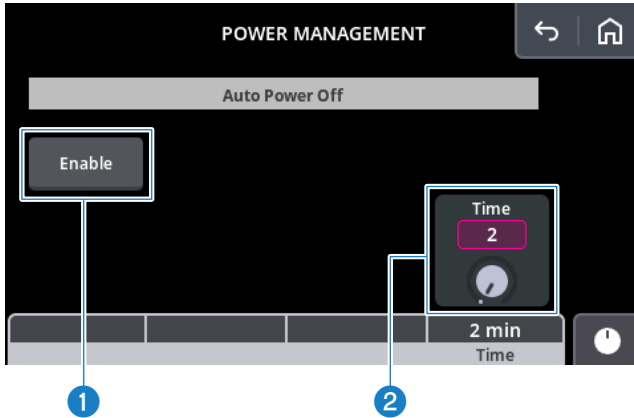

1 [Enable] button

Turns on the auto power off function.

2 [Time] knob

Touch near the knob or text to give the control focus. Use the [TOUCH AND TURN] knob to specify the time required from the time the unit is last operated until power off (non-operational time). This can be set within the range of 2–20 minutes in one-minute increments (the default setting is 20 minutes).

NOTE

Turning off (disabling) the auto power off function keeps the device powered on continuously, which will increase power consumption.

Date/Time menu (URX44V, URX44)

This menu is for setting the date and time of this unit.

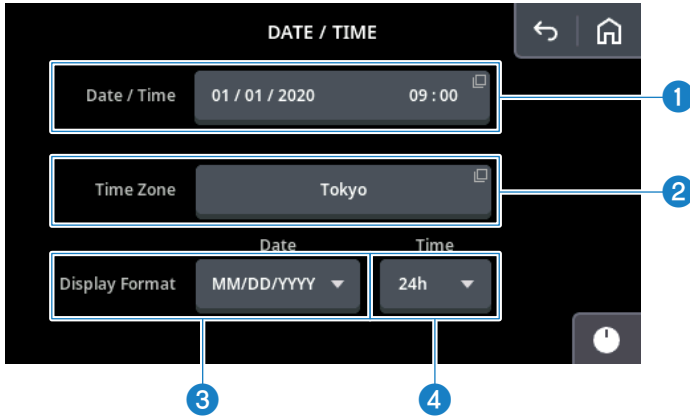

1 [Date/Time] popup button

Set the date and time on the screen that appears. Touch the item you want to change and operate the [TOUCH AND TURN] knob. When you've finished making the settings, touch the [OK] button to apply the settings and close the popup window. To close the popup window without applying the settings, touch the [Cancel] button.

2 [Time Zone] popup button

Selects the name of the city representing the time zone on the screen that's shown.

3 [Display Format] Date button

Selects the display format for the date.

4 [Display Format] Time button

Selects the display format for the time.

Software Integration menu (V1.2 and later)

This menu is shown when you connect your computer and launch the compatible software (Steinberg Cubase, Nuendo, MixKey). For details on software integration, see “Using the Software Integration functions (V1.2 and later)” (p.153).

■ DAW Integration menu

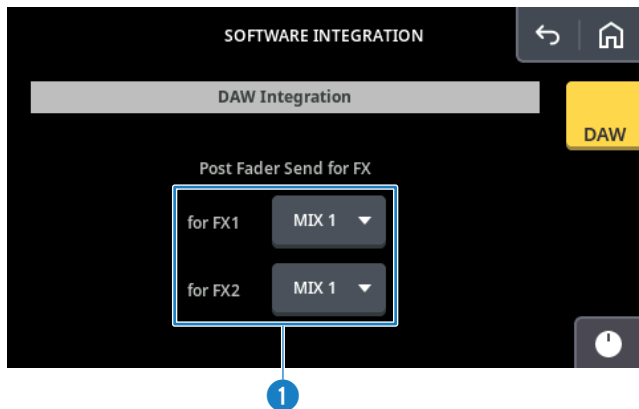

1 [Post Fader Send for FX] select button

Selects the MIX bus to send to FX1 and FX2. The send point is post-fader.

MONITOR screen

Top menu

This menu is for operating the signal used to check headphones or near-field monitors. It allows you to select the source to be continuously monitored, to change the monitor signal to mono and to operate the CUE function and so forth.

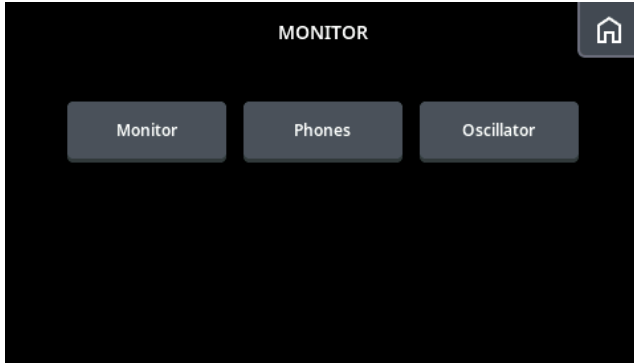

Monitor menu

This menu is for selecting [MONITOR] source 1 or 2 and setting the volume and other settings.

■ Level

This displays the parameter for adjusting the monitor volume.

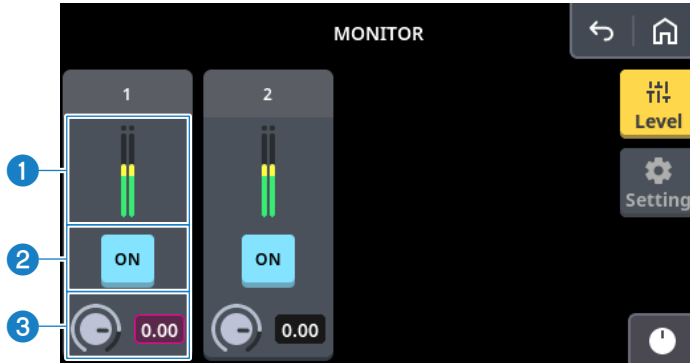

① **Level meter**

Shows the monitor output level.

② **[ON] button**

Switches each monitor output on/off.

③ **[Level adjustment knob/text box]**

Operate by using the [TOUCH AND TURN] knob or the multi-function knob.

■ Setting

This is for selecting the monitor source and configuring the CUE signal.

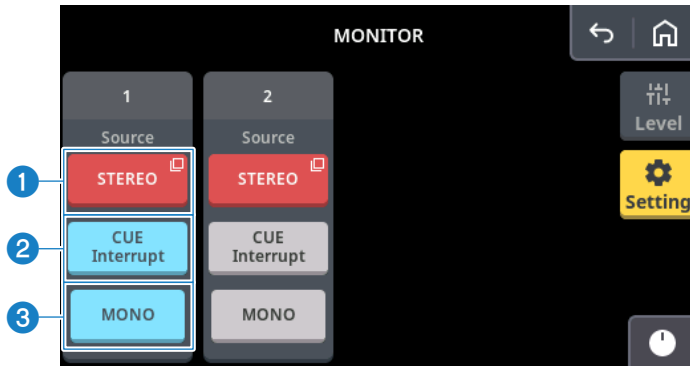

1 Monitor source selection button

The settings screen is shown when you touch this screen. You can select the monitor source from the screen that's shown. The screen closes automatically after selection.

2 [CUE Interrupt] button

Switches the function for interrupting the [CUE] signal to the monitor on/off. When this is on, turning the CUE on replaces the monitor output signal with the CUE signal. When this is off, the signal selected by the (1) monitor source mode button is output continuously.

3 [MONO] button

Switches the function on/off for converting the signal output to the monitor to monaural.

NOTE

Monitor 1 and 2 signals are output from PHONES 1 and 2. When outputting from the OUTPUT connectors, configure the settings in the "Output Patch menu" (p.58).

Phones menu

This adjusts the volume for [PHONES] 1 and 2.

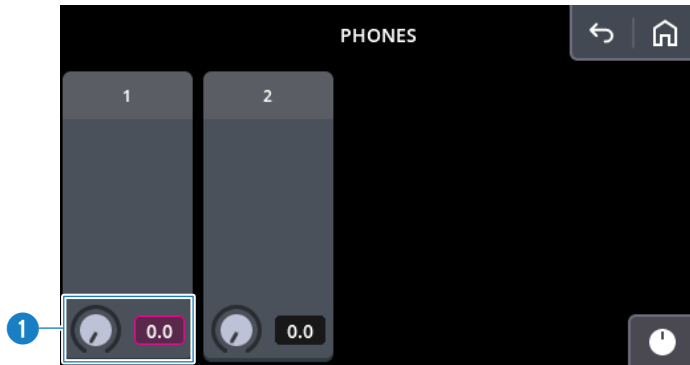

1 Level adjustment knob/text box

Adjust the level of signal output from the [PHONES] connectors using the multi-function knobs.

NOTE

The signals output from [PHONES] 1 and 2 are the same signals as specified for [MONITOR] 1 and 2. Only the signal levels can be operated independently (p.66).

4 **[Frequency]**

This is shown when the oscillator mode is [Sine Wave]. Sets the sine wave frequency. Operate by using the [TOUCH AND TURN] knob or the multi-function knob.

5 **[Width]**

This is shown when the oscillator mode is [Burst Noise]. Sets the length of noise. Operate by using the [TOUCH AND TURN] knob or the multi-function knob.

6 **[Interval]**

This is shown when the oscillator mode is [Burst Noise]. Sets the noise cycle. Operate by using the [TOUCH AND TURN] knob or the multi-function knob.

■ Assign

This sets the oscillator output for each bus.

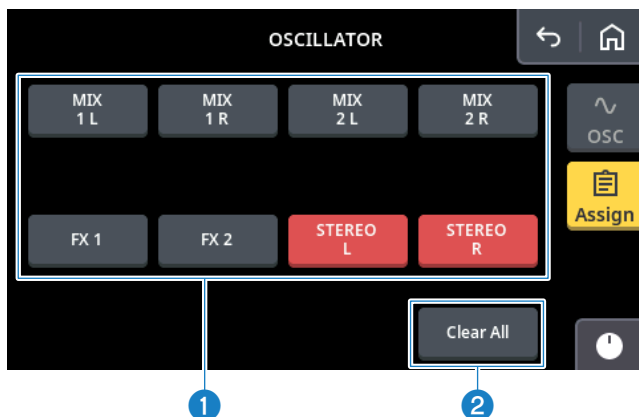

1 **Output bus assignment buttons**

Switches the oscillator output to each bus on/off.

NOTE

If the sampling frequency is 176.4 kHz or 192 kHz, then FX 2 cannot be assigned.

2 **[Clear All] button**

Turns off all bus assignments.

SCENE screen

Top menu

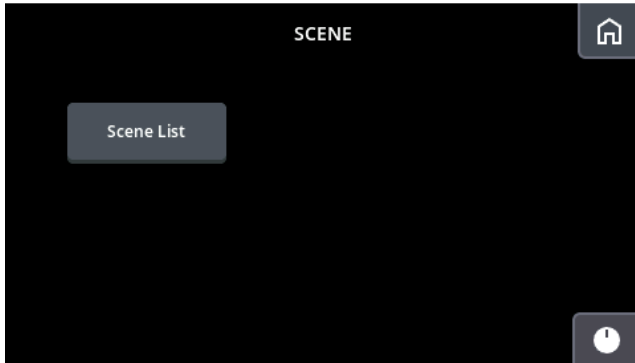

Scene List menu

■ Store/Recall

This screen is for managing the scenes you've saved that contain the mixer settings.

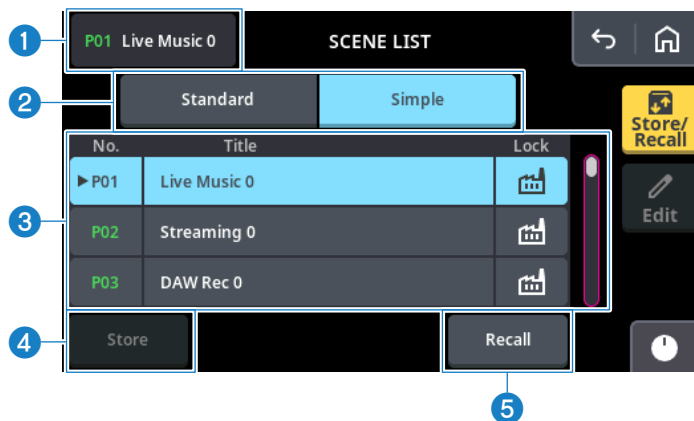

1 Current scene indication

Shows the currently selected scene number and name.

NOTE

If the selected scene number is different from the last scene number you recalled, the number flashes.

2 List bank selection

Switches between Scene List banks. Scenes are listed separately for each Operation Mode setting.

NOTE

You can't operate the Standard bank list when Operation Mode is set to Simple Mode.

3 Scene list

Shows the scenes that are saved.

No.

Shows the scene number (01–63). [▶] is shown for the last recalled scene.

Title

Shows the title name.

Lock

Shows the protect status. Scenes for which the protect setting is on cannot be overwritten.



: factory reset



: file for which the protect setting is on

NOTE

The scene numbers are the same for Standard Mode and Simple Mode. You can't register a scene with the same number. For example, if you register scene number [03] in Standard Mode, [03] does not show up in the list for Simple Mode.

4 [Store] button

Stores (saves) the current settings in the number that's selected in the list.

5 [Recall] button

Recalls (loads) the selected scene.

Edit

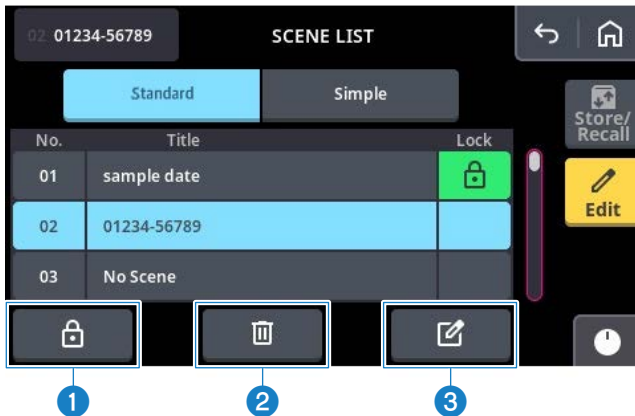

1 [Protect] button

Toggles the protect function (write prevention) for the selected scene on/off.

2 [Delete] button

Deletes the selected scene.

SCENE screen > Scene List menu

3 [Title] button

Edits the title name of the selected scene.

NOTE

In Standard Mode, you can refer to and recall the scene list from Simple Mode, but you can't store (save) or edit (protect, delete, edit) it.

■ Settings that are saved in a scene

The settings saved to the scenes mainly include the mixer channel settings. The following settings are not saved.

- Settings for the SETUP screen, MONITOR screen, microSD screen and STREAMING channel

In Simple Mode, both the Output Patch and Monitor settings are saved as necessary.

microSD screen (URX44V, URX44)

Top menu

This menu is for setting the microSD card that's inserted in this product.

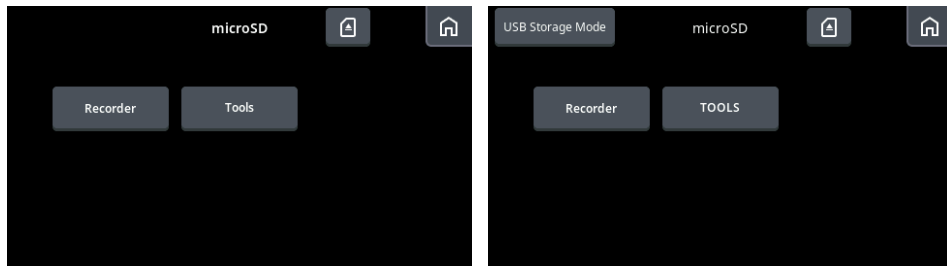

(V1.2 and later)

■ SD cards compatible with this product

microSD cards can be used on the URX44V and URX44. Use an SDXC microSD memory card or an SDHC memory card that fulfills the following performance characteristics.

- Cards with a UHS-I bus interface or greater, which operates under SDR104 bus speeds
- UHS speed class 1 or greater
- Speed class 10 or greater

NOTE

- Media with fast and stable write speeds is required for multitrack recording.
- The write speed of SD cards decreases as the media is used repeatedly. Be sure to format the media with the interface unit before making any important recordings.
- You can improve recording stability by limiting the number of tracks that are recorded (p.78).
- Use the Test function (p.83) to get an idea of the performance specs of your media.

You may not be able to record or play back correctly with some microSD cards.

For the latest information on compatible products, see the following Yamaha website.

<https://www.yamaha.com/2/urx/>

■ Handling SD cards

- Be careful of the front/back orientation and the direction when inserting a microSD card, and insert the card all the way. Do not force the card in.
- To remove a microSD card, touch  and follow the directions indicated in the dialog box. If “Now you may safely remove the microSD card.” is displayed, gently push in on the microSD card. When it pops out a little, pull out the card.

■ Formatting (initializing)

You will need to format (initialize) your microSD card if you are using it for the first time or if the card uses an unsupported file system.

If you see a dialog box asking you to format the media, touch [OK] to format. Formatting requires time. It takes about three minutes to format a 128 GB microSD card.

NOTICE

- It may take time for the card to be recognized, depending on the microSD card.
- All data will be completely erased from the microSD card once you format (initialize) it. If the card contains data that you need, back the data up beforehand to your computer, and then format the card.

microSD screen (URX44V, URX44) > USB Storage Mode button (V1.2 and later)

USB Storage Mode button (V1.2 and later)

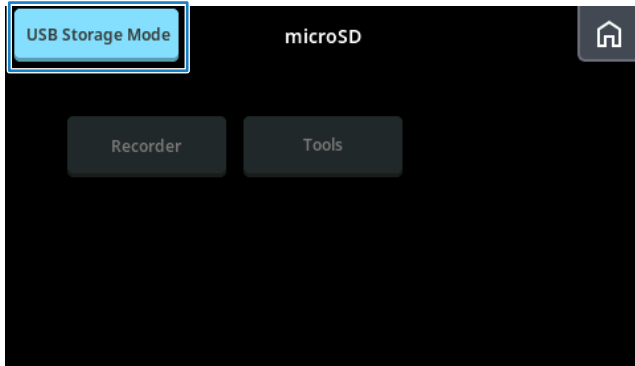

When the USB Storage Mode button is on (lit up light blue), the microSD card is recognized as a drive by the computer, and you can use it to read and write files. The files can be accessed by a computer that's connected to the [USB MAIN] connector.

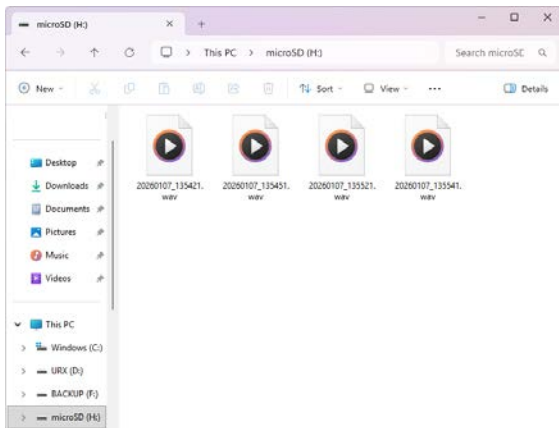

NOTE

You cannot access any other menus from this product while USB Storage Mode is on.

RECORDER menu

■ Record

Sets the recording source for recording to the microSD card.



1 [Track Count]

Select the number of tracks to record using the pulldown menu that's shown, in groups of two tracks.

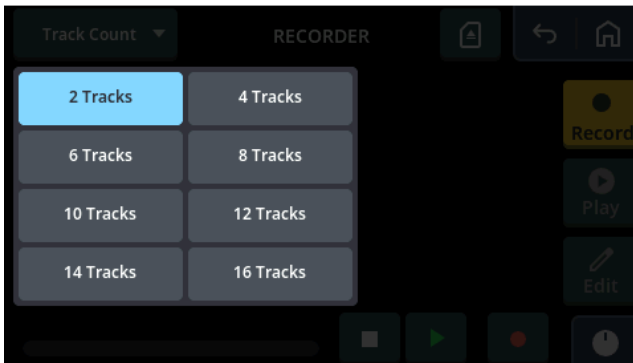

2 [Source] select button

Touch this button to select the recording source from the screen that's shown.

microSD screen (URX44V, URX44) > RECORDER menu

NOTE

(URX44V)

For purposes of copyright protection, audio that is protected by HDCP cannot be recorded to an SD card. Select “HDMI” for the input source of either input channel to output the HDMI audio to all output channels. If the HDMI input signal is HDCP-protected, the audio sent to the SD card from these channels is automatically muted.

3 Record source meter

Shows the recording source level.

4 Sampling frequency

Shows the sampling frequency during recording (only while recording).

5 Counter

Shows the recording time.

6 Progress bar

Shows the remaining free space on the microSD card.

7 Buttons used for recording



[REC]: Sets or cancels record standby.



[Play/Pause]: Starts/pauses the recording.



[Stop]: Ends the recording.

NOTE

Multitrack audio files that contain more than two tracks cannot be played back on this product. Copy the files to your computer and load them into your DAW or other software.

■ Play

This menu is for selecting the recorded data or a file that supports playback, and operating the playback features.

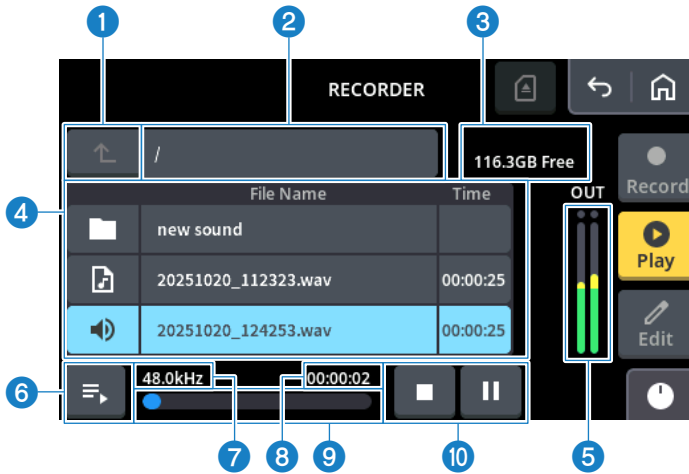

1 [Back] button

Moves to the topmost folder in the folder architecture on your microSD card.

2 **Folder name display**

Shows the path from the root directory to the current folder. If the path name doesn't fit in the display, it is shown from the end.

3 **Volume name/capacity display**

Shows the name of the microSD card and the remaining free space.

4 **List of files that can be played back**

Shows the files that can be played back in the selected folder, and the folder one level below.

List icons



Folder one level below



Audio file that can be played back



Audio file now playing

NOTE

- The number of the files in a folder should be limited to 128.
- Files can be played back if they meet the following conditions.
 - 32-bit, 24-bit, and 16-bit stereo linear PCM audio files in WAV format
 - Files with the same sampling frequency as used on this product

5 Meter

Shows the meter in stereo for the audio that's playing back.

6  button

Touch this button to move the cursor to the file that's playing back.

7 Sampling frequency display

Shows the sampling frequency during playback (only while playing back).

8 Counter

Shows the playback time.

9 Progress bar

Gives a visual indication of the playback time for the file that's now playing back.

10 Buttons used for playback

The buttons start, pause and otherwise control the playback.



[Stop]

Stops the playback of the file.



[Pause]

Starts/pauses the playback.

NOTE

To play another file while one is currently playing, first stop playback using the [Stop] button, then start playback using the [Play/Pause] button.

■ Edit

This screen is for editing the filenames on the microSD card and for deleting files.

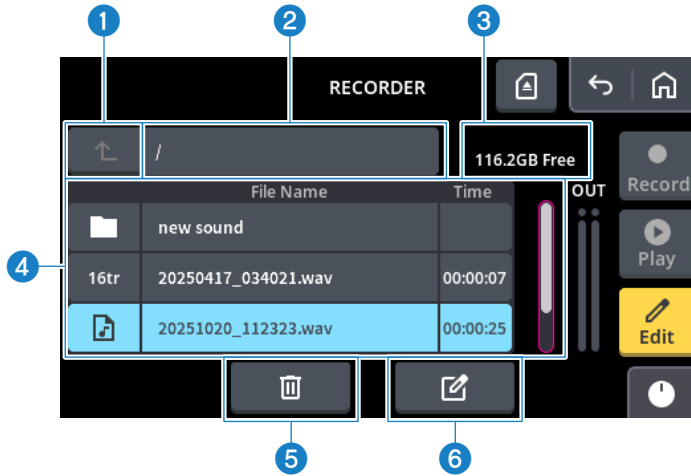

1 [↑] **button**

Moves to the topmost folder in the folder architecture on your microSD card.

2 **Folder name display**

Shows the path from the root directory to the current folder. If the path name doesn't fit in the display, it is shown from the end.

3 **Volume name/capacity display**

Shows the name of the microSD card and the remaining free space.

4 **List of files that can be played back**

Shows the files that can be played back in the selected folder, and the folder one level below.

List icons



: Folder one level below



: Audio file that can be played back

4tr-16tr: Number of audio file tracks recorded on this product

44.1 kHz, 48 kHz: 4tr, 6tr, 8tr, 10tr, 12tr, 14tr, 16tr

88.2 kHz, 96 kHz: 4tr, 6tr, 8tr

5 [🗑️] **button**

Deletes the selected file.

6 [✎] **button**

Edits the selected filename.

TOOLS menu

■ Format

Formats (initializes) the microSD card.

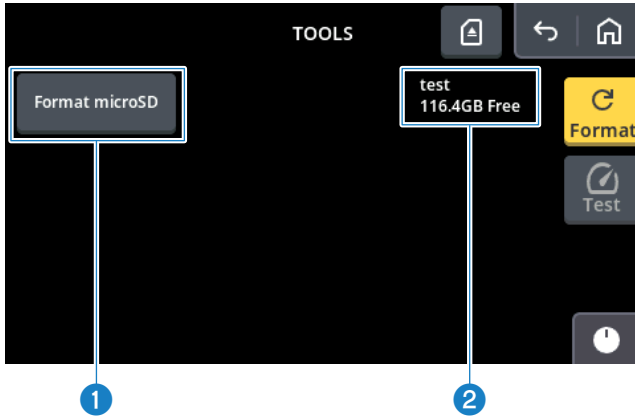

① **[Format microSD] button**

Once you input a volume label and touch the [OK] button, the formatting of the microSD card is executed.

② **Volume name/capacity display**

Shows the name of the microSD card and the remaining free space.

microSD screen (URX44V, URX44) > TOOLS menu

■ Test

Evaluates the write speed of the microSD card.

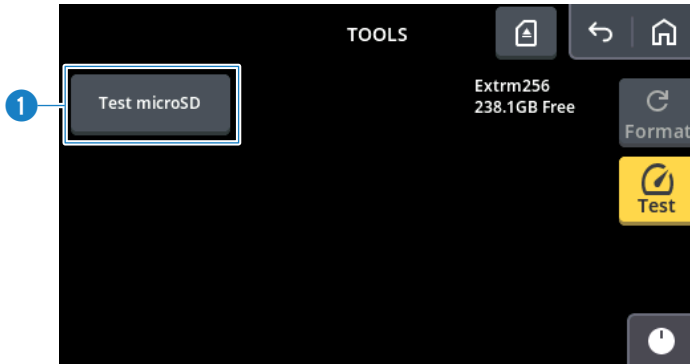

1 [Test microSD] button

Touch this button to begin the analysis. The result is shown after about 10 seconds.

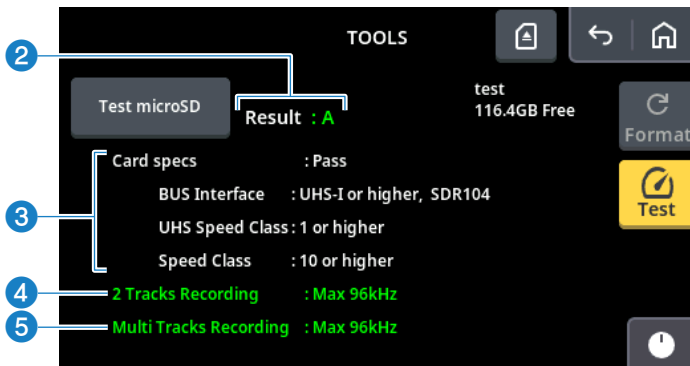

2 [Result]

A general evaluation rating is given, either [A], [B], [C] or [NG] (no good).

[A] rating (green): both Multi Tracks and 2 Tracks can be recorded, and all Card specs are Pass

[B] rating (yellow): Multi Tracks recording is possible if the frequency is selected, and all Card specs are Pass

[C] rating (orange): 2 Tracks recording is possible if the frequency is selected, and all Card specs are Pass

An [NG] rating is assigned in all other cases.

3 [Card specs]

Whether or not any card specification problems exist is determined based on [Pass] (no problems) or [Fail] (problem exists).

This displays the specifications of the interface or speed class, which are displayed in red if the specs are not met.

4 [2 Tracks Recording]

This performs a write test and displays the maximum sampling rate compatible with two-track recording.

The evaluation results are shown as follows.

- Green: two-track recording can be done at any frequency
- Yellow: recording can be done if the sampling frequency is equal to or higher than the current sampling frequency of this unit
- Red: recording can be done only at sampling frequencies that are lower than the current sampling frequency of this unit
- [Fail] (red): recording cannot be done at any frequency

If the setting in interface unit is 48 kHz, then:

[Max 192kHz] (green): Recording is possible at 44.1 kHz, 48 kHz, 88.2 kHz, 96 kHz, 176.4 kHz, or 192 kHz

[Max 96kHz] (yellow): Recording is possible at 44.1 kHz, 48 kHz, 88.2 kHz, or 96 kHz, but not possible at 176.4 kHz or 192 kHz

[Max 48kHz] (yellow): Recording is possible at 44.1 kHz or 48 kHz, but not possible at 88.2 kHz, 96 kHz, 176.4 kHz, or 192 kHz

[Max 44.1kHz] (red): Recording is possible at 44.1 kHz, but not possible at 48 kHz, 88.2 kHz, 96 kHz, 176.4 kHz, or 192 kHz

[Fail] (red): Recording cannot be done at any frequency

5 [Multi Tracks Recording]

This performs a write test and displays the maximum sampling rate compatible with multitrack recording.

If [Max 96kHz] is shown green, the write speed allows for 48 kHz/16-track and 96 kHz/8-track recording. If the conditions are not met, [Fail] is shown in red.

Channel view

Screen layout



- The main area screen display changes according to each channel.
- A summary of the parameters for the selected channel is shown in the main area. The items that are shown will change depending on the selected channel.
- Touch each object in the main area to target the relevant parameter for operation. Touch them again to switch to a details screen for the function in question.
- For details on each function, refer to “Dedicated channel screen ” (p.95).

Toolbar

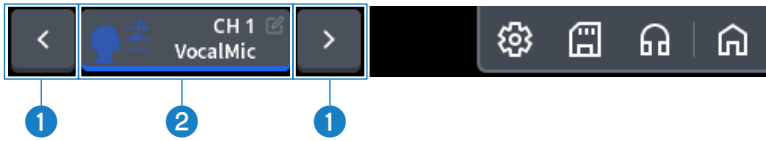

1 Channel selection buttons

Touch [←] to switch to the previous channel, and [→] to switch to the next channel. The channel selection loops from CH1 to STREAMING, or from STREAMING to CH1.

2 Channel settings screen display button

The channel settings screen is shown when you touch this button. Refer to the next page for more on the channel settings screen.

Channel settings screen

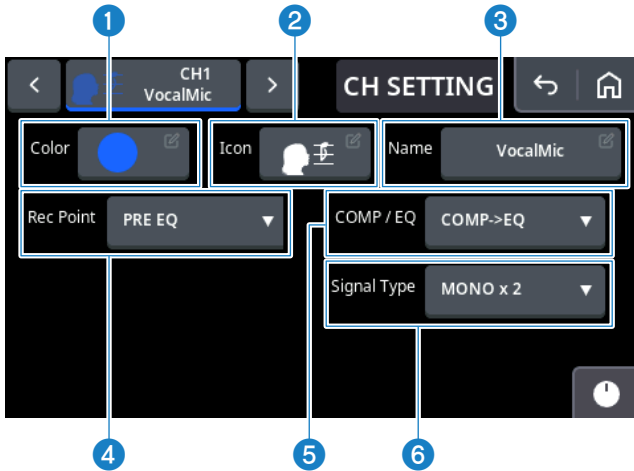

NOTE

The items shown differ depending on the channel.

- 1 [Color]**
Selects the channel color.
- 2 [Icon]**
Selects the channel icon. Scroll through the icon list to make a selection.
- 3 [Name]**
Enter the channel name. The text input screen is shown when you touch this button.
- 4 [Rec Point]**
This lets you select the point within the signal path from which to directly record the signal of a channel.
- 5 [COMP/EQ]**
You can select whether to use the channel's COMP/EQ as a COMP -> EQ or as an SSMCS (Sweet Spot Morphing Channel Strip).
- 6 [Signal Type]**
Enables selecting operation modes for two adjacent channels (Ch 1 and 2, Ch 3 and 4, MIX 1 and 2, MIX 3 and 4, etc.). Select from either stereo link (STEREO) or two independent channels (MONO x 2).

NOTE

(V1.2 and later)

When you select STEREO for the MONO IN channel, a button is shown that lets you select between PAN and BAL (balance). You can select whether to use the respective channels as a PAN or as the L/R balance.

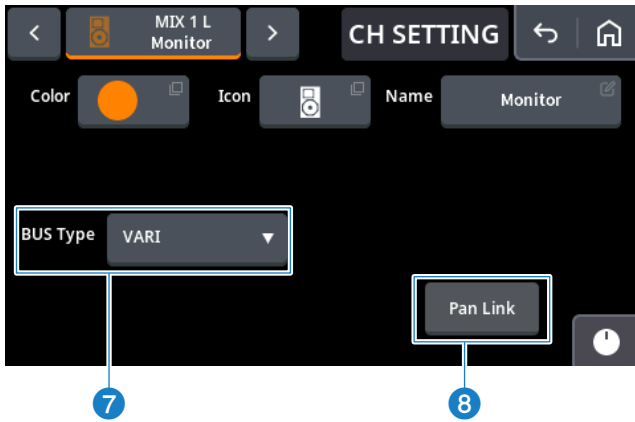
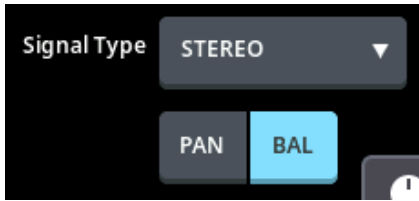

7 [BUS Type]

Enables selecting MIX 1 and MIX 2 bus types. Select either VARI (variable send level) or FIXED (fixed send level) for the bus type.

8 [Pan Link]

You can configure a function that links the send pan settings from the send source channel to the channel PAN. This function is enabled when the bus type is VARI. Touch the button to switch between PAN settings.

Main area

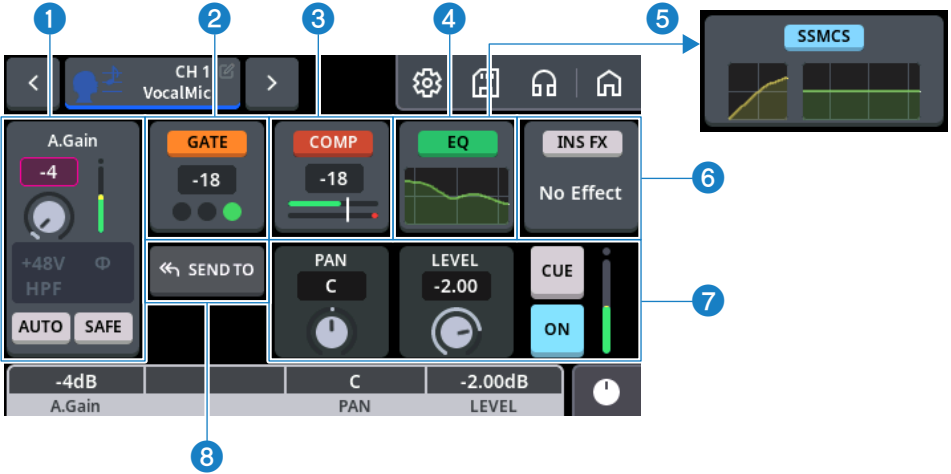

1 Input area

This area includes the input gain, input meter, [+48V] indicator, [ϕ] indicator, [HPF] indicator, [AUTO] button, [SAFE] button and so forth.

MONO IN channel		
If the MIC/LINE INPUT connector is selected as the input source	If the MIC/LINE /HI-Z INPUT connector is selected as the input source	Another input besides those listed at left is selected as the input source
ST IN channel		
If the MIC/LINE INPUT connector is selected as the input source	If the MIC/LINE /HI-Z INPUT connector is selected as the input source	Another input besides those listed at left is selected as the input source

■ Explanation of the indicator buttons

The items that are shown differ depending on the selected channel. Here we explain some of these items. For a description of other indicators and buttons, refer to “INPUT screen” (p.96) in “Dedicated Channel screens”.

- **AUTO:** This is the auto-gain button. Touch this from the off position to turn it on and start the auto-gain settings. When the correct input gain is determined, it is reflected in the analog input setting value, and the button automatically turns off.
- **SAFE:** This is the clip safe button. When this is on, the gain is automatically lowered to avoid clipping when excessive input is detected. The button color changes from light blue to orange when the gain is automatically lowered.

2 GATE area (MONO IN channel only)



Touch the GATE button to switch the gate on/off. Use the [TOUCH AND TURN] knob to set the threshold. Touch within the area to open the [GATE] screen.

The lower indicators show the open/close status of the GATE.



GATE is completely closed (gain reduction is at or below the RANGE)



GATE is in the middle of opening or closing (gain reduction is equal to or greater than RANGE, but less than 0 dB)



GATE is completely open (gain reduction is 0 dB)



GATE is off

3 COMP area (MONO IN channel only)

Touch the COMP button to switch the compressor on/off. The parameters you can operate with the [TOUCH AND TURN] knob differ depending on whether 1-knob mode is on or off. When it is off, you can set the threshold. When it is on, you can set the effect depth within 0–100%. Touch within the area to open the [COMP] screen. For the lower indicators, the top indicator shows the input level, and the bottom indicator shows the gain reduction.

NOTE

About the **1-knob** function

When you turn 1-knob on, you can easily operate multiple parameters with the [TOUCH AND TURN] knob. When 1-knob is on, the parameters cannot be operated individually. You can set 1-knob on/off in the dedicated channel screen.

- When 1-knob is off

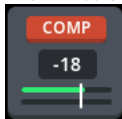

Touching anything else besides the [COMP] button gives it focus with a pink border. Operate the [TOUCH AND TURN] knob to set the threshold.

- When 1-knob is on

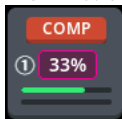

Operate the [TOUCH AND TURN] knob to set the value. Touch within the area to display the [COMP] screen.

4 EQ area

Touch the EQ button to switch the EQ on/off. When 1-knob mode is on, you can use the [TOUCH AND TURN] knob to set the effect depth within 0–100%. The graph below shows the EQ frequency characteristics. Touch within the area to open the [EQ] screen.



When 1-knob mode is off

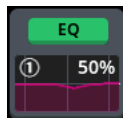

When 1-knob mode is on

5 SSMCS area (MONO IN channel only)

When the [COMP/EQ] TYPE is SSMCS, the COMP area and EQ area are swapped. Touch the SSMCS button to switch the SSMCS on/off. Touch within the area to display the [SSMCS] screen.

NOTE

- SSMCS (Sweet Spot Morphing Channel Strip) is a function built into Yamaha USB audio interfaces, which lets you adjust the EQ and compressor to the optimum balance using a single knob.
- The [COMP/EQ] type can be changed in the “Channel settings screen” (p.88).

6 INS FX area

Touch the INS FX button to switch it on/off. If no effect is inserted, [No Effect] is shown. Touch within the area to display the [INS FX] screen.

7 PAN/LEVEL area

Shows the channel ON, CUE, PAN settings and the LEVEL meter for the channel.



[PAN] knob/[BALANCE] knob

Shows the stereo position of the signal.

You can set the PAN/BALANCE by using the [TOUCH AND TURN] knob or the multi-function knob. [C] indicates the nominal (center) position.

NOTE

(V1.2 and later)

When you select STEREO for Signal Type (p.88) and select [BAL] from the PAN/BAL button that's shown, the BALANCE knob can be displayed in the MONO IN channel.

[LEVEL] knob

Shows the level for the channel. The level can be adjusted by operating the [TOUCH AND TURN] knob or multi-function knob.

[CUE] button

Toggles CUE on/off for the channel. This lights up when CUE is on.

[ON] button

Toggles the channel on/off. This lights up when the channel is on.

LEVEL meter

This is a level indicator with a range of -60 dB to 0 dB.

Stereo channels and channels that are stereo-linked are shown with a stereo meter.





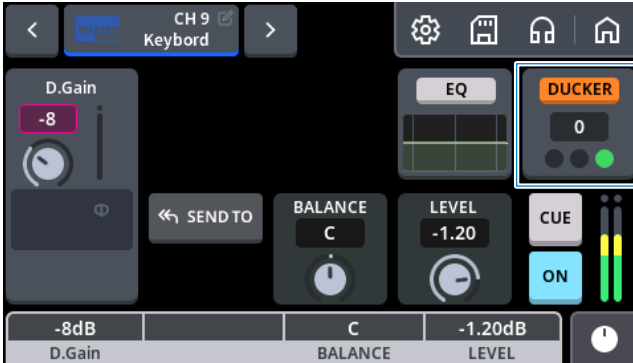

8 SEND TO button

Touch this button to switch to the [SEND TO] screen.

9 **DUCKER area (ST IN channel only)**



Touch the DUCKER button to switch it on/off. Use the [TOUCH AND TURN] knob to set the threshold. The lower indicators show the operational status of the DUCKER.

-   DUCKER is completely attenuated (gain reduction is at or below the RANGE)
-   DUCKER is in the middle of attenuating (gain reduction is equal to or greater than RANGE, but less than 0 dB)
-   DUCKER is not operating (gain reduction is 0 dB)
-  DUCKER is off

10 **DELAY area (only STREAMING channel)**

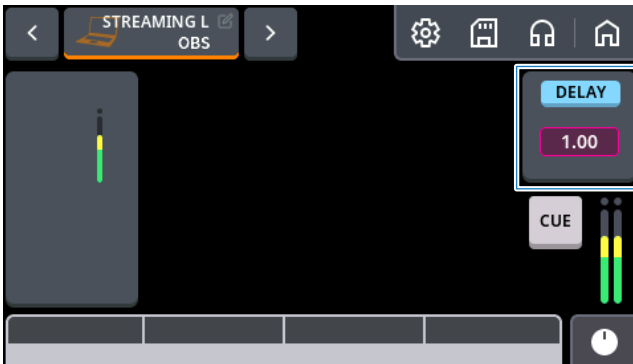

Touch the DELAY button to switch it on/off. Use the [TOUCH AND TURN] knob to set the delay time. Touch within the area to display the [DELAY] screen.

Dedicated channel screen

Channel settings screen

This screen is for configuring the detailed settings for the module of each channel.

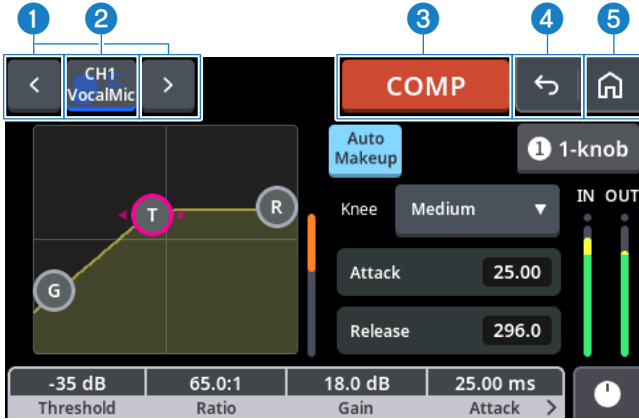

Common buttons for each screen

1 Channel selection buttons

Touch [←] to switch to the previous channel, and [→] to switch to the next channel.

2 Channel name display area

Shows the selected channel name.

3 Module on/off button

Shows the module name. Also, when the following functions are selected, this switches the module on/off. When you click to turn this off (displays in gray), the function is disabled.

GATE, COMP, EQ, SSMCS, INS FX, DUCKER, DELAY

4  button

Returns to the channel view display.

5  button

Shows the HOME screen.

INPUT screen

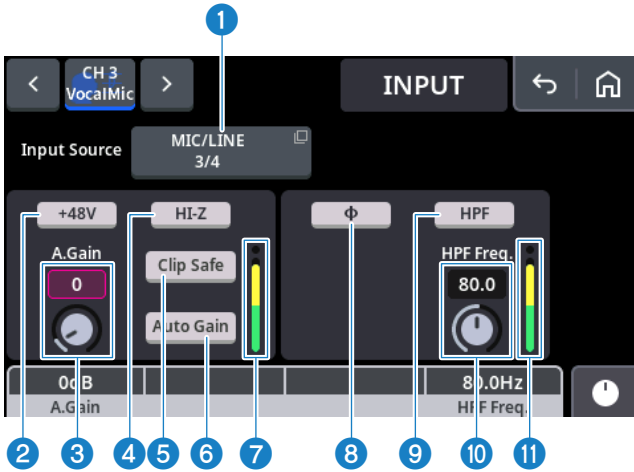

1 [Input Source] select button

Shows the input source selection popup menu. When you select an input source, you can select the input level. For monaural input channels, this sets two adjacent channels as a group.

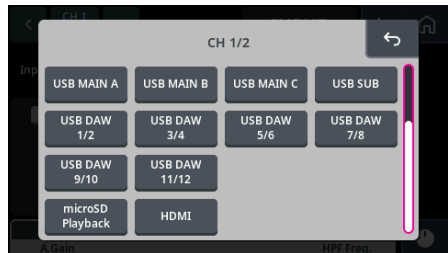

URX44V or URX44 (HDMI on URX44V model only)

- **[All Input]** button: When “OK” is selected on the dialog box that’s shown, the input source for Ch 1/2–Ch 11/12 is set according to the table below.

URX44V, URX44

Ch 1/2	Ch 3/4	Ch 5/6
MIC/LINE 1/2	MIC/LINE 3/4	AUX IN
Ch 7/8	Ch 9/10	Ch 11/12
Not updated	Not updated	Not updated

URX22

Ch 1/2	Ch 3/4	Ch 5/6
MIC/LINE 1/2	AUX IN	Not updated
Ch 7/8	Ch 9/10	-
Not updated	Not updated	-

NOTE

- If a mic is connected to the [HEADSET] connector, the audio signal from the [MIC/LINE INPUT 1] connector on the rear panel is not input.
- If a headphones connector is connected to the [HEADSET] connector, the audio sound from [PHONES 1] is muted.
- **[All USB DAW]** button: When “OK” is selected on the dialog box that’s shown, the input source for Ch 1/2–Ch 11/12 is set according to the table below.

URX44V or URX44 (CH 1/2 to CH 9/10 for URX22)

Ch 1/2	Ch 3/4	Ch 5/6
USB DAW 1/2	USB DAW 3/4	USB DAW 5/6
Ch 7/8	Ch 9/10	Ch 11/12
USB DAW 7/8	USB DAW 9/10	USB DAW 11/12

NOTE

(URX44V)

For purposes of copyright protection, audio that is protected by HDCP cannot be output to USB or recorded to an SD card. Select “HDMI” for the input source of either input channel to output the HDMI audio to all output channels. If the HDMI input signal is HDCP-protected, the audio sent to USB or the SD card from these channels is automatically muted.

2 [+48V] button

Switches the phantom power (+48V) on/off. This is shown when the MIC/ LINE input is selected as the input source. The phantom power supply and HI-Z cannot be turned on at the same time.

Precautions regarding phantom power

- Observe the following precautions in order to avoid malfunctions on this or on an external device, and to avoid noise.
- Turn this off if you don’t need phantom power.
- Turn this off if you have connected a device that does not support phantom power to the [INPUT] connectors.
- Do not plug in or unplug any cables connected to the [INPUT] connectors while this is on.
- Turn this on/off while the output volume is turned all the way down.

3 [A.Gain] knob

Sets the analog gain. This is shown when the MIC/ LINE input is selected as the input source.

NOTE

When something other than a MIC/LINE input connector is selected, the [D.Gain] knob is shown and you can set the digital gain.

4 [HI-Z] button

This is displayed if the [MIC/LINE INPUT 3, 4] connectors is selected as the input source on URX44V or URX44 models, or if the [MIC/LINE INPUT 2] connector is selected as the input source on the URX22.

5 [Clip Safe] button

When this is on, the gain is automatically lowered to avoid clipping when excessive input is detected. The button color changes from light blue to orange when the gain is automatically lowered. This is shown when MIC/ LINE input is selected as the input source.

6 [Auto Gain] button

When this is on, auto gain measurements begin. When the correct input gain is determined, it is reflected in the analog input setting value, and the button automatically turns off. This is shown when MIC/ LINE input is selected as the input source.

NOTE

Vocalize or make sounds while the auto gain is being measured. If the audio input is too low, an error will result and the previous gain value is used.

7 Input meter

Shows the level for the channel directly after input.

8 [ϕ] button

Switches between ϕ (phase) (the phase is inverted when on, and normal when off).

9 [HPF] button

Switches the [HPF] (high-pass filter) on/off.

10 [HPF Freq.] knob

Sets the [HPF Freq.] (HPF frequency).

11 Output meter

Shows the level after passing through ϕ or HPF.

GATE screen

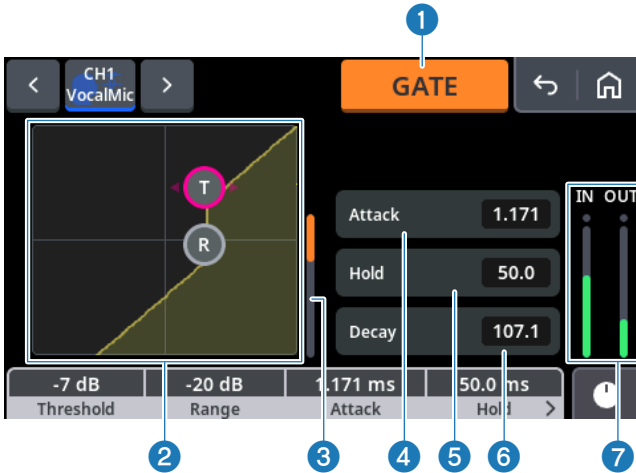

1 [GATE] button

Switches the gate on/off.

2 GATE graph

Displays the input/output response of the gate in a visual way. Directly manipulate the graph to set the threshold level at which the effect is applied (T), and the attenuation amount when the effect is applied (R).

3 GR (gain reduction) meter

Shows the amount of gain reduction.

4 [Attack] text box

Sets the attack time.

5 [Hold] text box

Sets the hold time.

6 [Decay] text box

Sets the decay time.

7 Input/output meter

Shows the input/output signal levels to the gate.

COMP screen

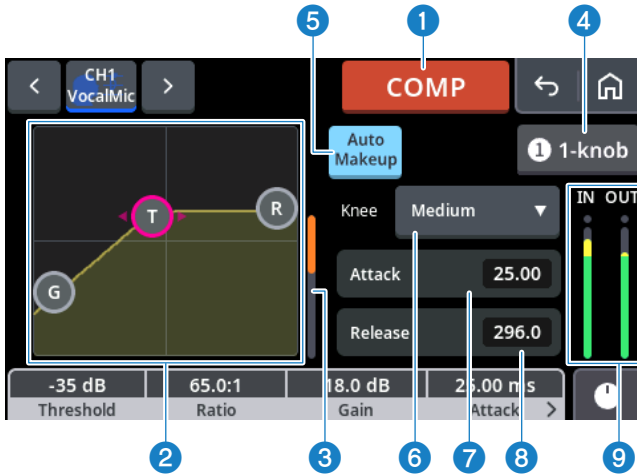

1 [COMP] button

Switches the compressor on/off.

2 COMP graph

Displays the input/output response of the compressor in a visual way. Directly manipulate the graph to set the values for T (threshold), R (ratio), and G (gain).

3 GR (gain reduction) meter

Shows the amount of gain reduction for the compressor.

4 [1-knob] button

Switches the 1-knob function on/off.

If 1-knob is on:

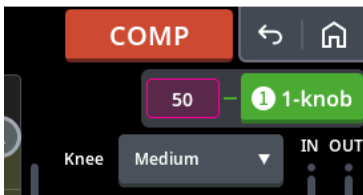

How 1-knob COMP works

- When 1-knob is on, you can easily control how much compression is applied with a single knob.
- The compression gets stronger and the level gets higher as the 1-knob level value is increased. This evens out signals with wide volume fluctuations (where simply raising the fader or gain would cause clipping), making the sound more prominent in the mix.
- This automatic control over the balance between threshold, ratio and gain lets you use the compressor without worrying about making complicated settings.

5 [Auto Makeup] button

Switches the Auto Makeup function on/off. When this is turned on, the appropriate gain is automatically calculated based on the threshold and ratio settings. The calculated gain value is automatically applied. This cannot be operated when 1-knob is on.

6 [Knee] mode selector

Switches between the knee parameters (the change in volume before and after the threshold level). This cannot be operated when 1-knob is on.

7 [Attack] text box

Adjusts the attack time (how fast compression begins after the input signal exceeds the threshold level).

8 [Release] text box

Adjusts the release time (how fast compression is released after the input signal exceeds the threshold level).

9 Input/output meter

Shows the input/output signal levels to the compressor.

EQ screen

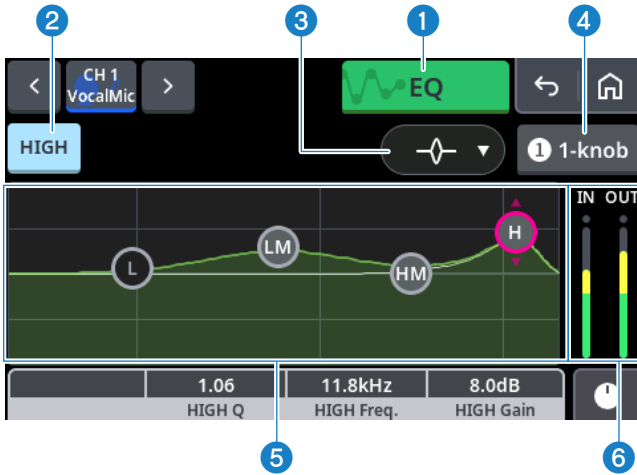

1 [EQ] button

Switches the EQ on/off.

2 Band name display

Shows the selected band name. Touch to switch the band on/off. This cannot be operated when 1-knob is on.

3 Filter selection button

Selects the filter type.

This cannot be operated when 1-knob is on.

4 [1-knob] button

Switches the 1-knob function on/off.

When 1-knob is on

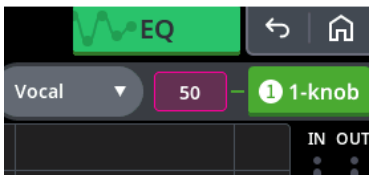

How 1-knob EQ works

- When 1-knob is on, you can use a single knob to control multiple parameters at the same time. That allows performing complex EQ adjustments easily.
- Turn off the 1-knob, configure EQ settings, and then change the 1-knob type setting to “Intensity” to register EQ settings at 50% levels (midpoint values). In that state, the [TOUCH AND TURN] nob can be used to adjust EQ settings within the range from 0% (no equalization applied) to 100% (enhanced more than midpoint values). That is convenient for using a single knob to make fine adjustments to pre-configured EQ settings.
- By changing the 1-knob type to [Vocal] or [Loudness], a previously prepared EQ curve can be used to adjust EQ settings between 0% (no EQ applied) and 100% (maximum EQ applied).

5 EQ graph

Drag the points in the EQ graph to control the gain/frequency characteristics. The graph cannot be operated when 1-knob is on.

6 Input/output meter

Shows the input/output signal levels to the EQ.

SSMCS (Sweet Spot Morphing Channel Strip) screen

Main screen

The Sweet Spot Morphing Channel Strip is a channel strip effect that uses Sweet Spot Morphing Technology developed by Yamaha. This lets you use a single knob to adjust the EQ and compressor to the optimum balance, and works for effects that are difficult to get the optimum effect from without specialized knowledge, such as the compressor and equalizer.

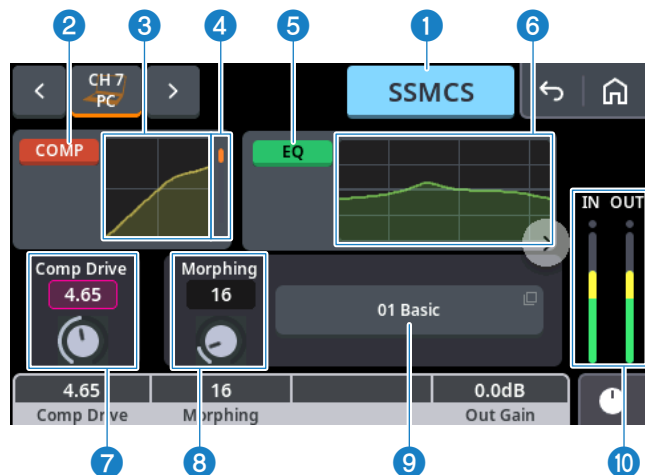

- 1 **[SSMCS] button**
Switches the SSMCS (Sweet Spot Morphing Channel Strip) on/off.
- 2 **[COMP] button**
Switches the compressor on/off.
- 3 **[COMP] graph**
Shows your direct operations of the input/output response graph for the compressor.
- 4 **[GR] (gain reduction) meter**
Shows the amount of gain reduction.
- 5 **[EQ] button**
Switches the EQ on/off.
- 6 **[EQ] graph**
Shows the frequency characteristics graph of the EQ.
- 7 **[Comp Drive] knob**
Sets how much the channel strip compressor is applied.

Dedicated channel screen > SSMCS (Sweet Spot Morphing Channel Strip) screen

8 **[Morphing] knob**

Adjusts the parameter of the Sweet Spot Data. You can simultaneously adjust the compressor and equalizer settings (Sweet Spot Data), which are set at five points around this knob by turning this knob. When you set the knob to the middle of two adjacent points, the compressor and equalizer settings will be set to an intermediate value.

9 **[Sweet Spot Data] button**

Tap to select the Sweet Spot Data from the list that's shown.

10 **Input/output meter**

Shows the input/output signal levels to the SSMCS.

COMP screen

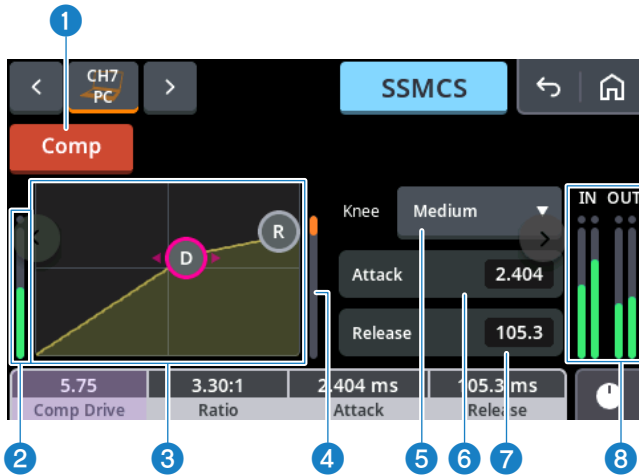

- 1 **[Comp] button**
Switches the compressor on/off.
- 2 **[SC] meter**
Shows the sidechain meter.
- 3 **[Comp] graph**
Lets you set the compressor by directly operating the input/output response graph.
- 4 **[GR] meter**
Shows the amount of gain reduction.
- 5 **[Knee] mode selector**
Switches between the knee parameters (the change in volume before and after the threshold level).
- 6 **[Attack] text box**
Sets the attack time.
- 7 **[Release] text box**
Sets the release time.
- 8 **Input/output meter**
Shows the input/output signal levels to the SSMCS.

COMP Side Chain screen

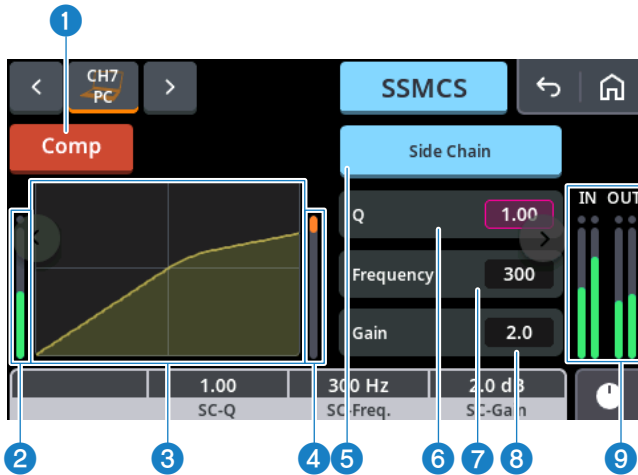

- 1 [Comp] button**
Switches the compressor on/off.
- 2 [SC] meter**
Shows the sidechain meter.
- 3 [COMP] graph**
Displays the input/output response graph of the compressor.
- 4 [GR] (gain reduction) meter**
Shows the amount of gain reduction.
- 5 [Side Chain] button**
Toggles the sidechain filter on/off.
- 6 [Q] text box**
Sets the Q value.
- 7 [Frequency] text box**
Sets the frequency.
- 8 [Gain] text box**
Sets the gain.
- 9 Input/output meter**
Shows the input/output signal levels to the SSMCS.

EQ screen

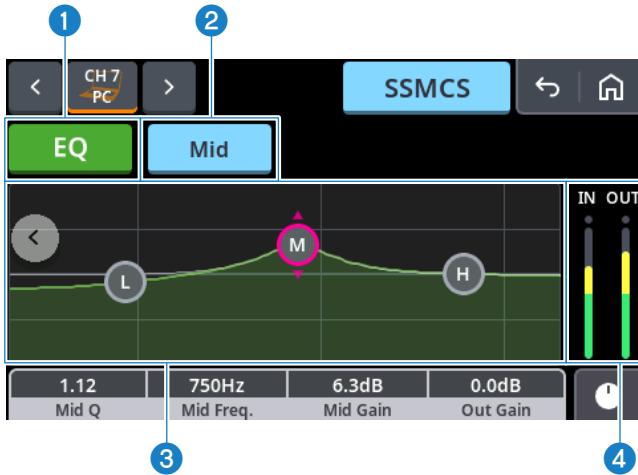

- 1 [EQ] button**
Switches the EQ on/off.
- 2 Band name display**
Shows the selected band name. Touch to switch the band on/off.
- 3 [EQ] graph**
Lets you set each band by directly operating the EQ graph.
- 4 Input/output meter**
Shows the input/output signal levels to the SSMCS.

INS FX screen

This screen is for configuring the inserted effects.

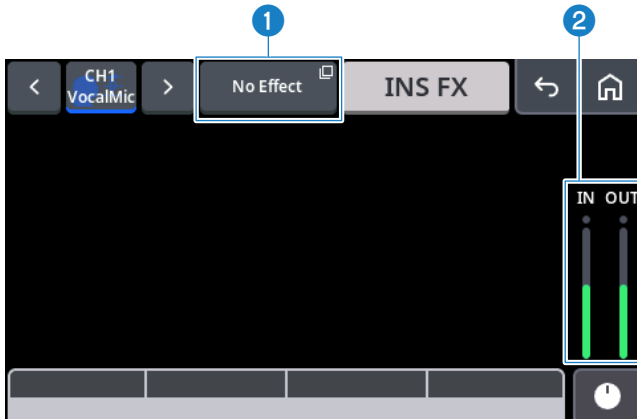

1 Effect menu popup button

Shows the screen for selecting the effect type. The effect that's shown differs depending on the selected channel. After selecting the effect, the assigned effect name is shown.

2 Input/output meter

Shows the input/output signal levels to the INS FX.

NOTE

For details on the parameter settings of each effect, refer to the “Effect Reference Guide” (link shown below). For the effect limitations, refer to the “Effect list” (p.180).

- https://manual.yamaha.com/audio/music_audio_production/effect_rg/

DUCKER screen

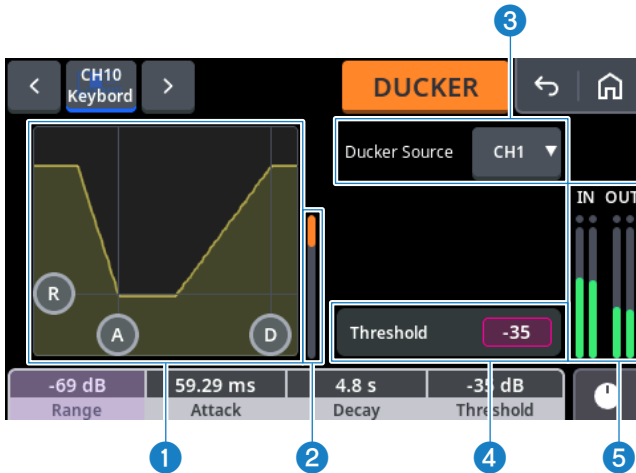

1 [DUCKER] graph

Shows the settings of the ducker in a visual way. Directly control the graph to set the attenuation amount for the R (Range) effect, the time from exceeding the threshold to full attenuation for the A (Attack Time), and the time from falling below the threshold to returning to the original volume for the D (Decay Time).

2 [GR] (gain reduction) meter

Shows the amount of gain reduction.

3 [Ducker Source] select button

Selects the ducker source.

4 [Threshold] text box

Sets the threshold.

5 Input/output meter

Shows the input/output signal levels to the ducker.

DELAY screen

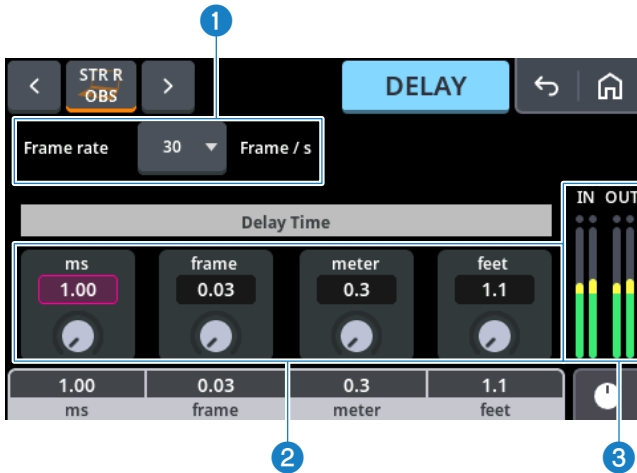

- 1 [Frame rate] select button**
Sets the frame rate.
- 2 [Delay Time] knob**
Sets the delay time for each of the units.
- 3 Input/output meter**
Shows the input/output signal levels to the delay.

SEND TO screen

This screen is for configuring the MIX SEND and FX SEND settings.

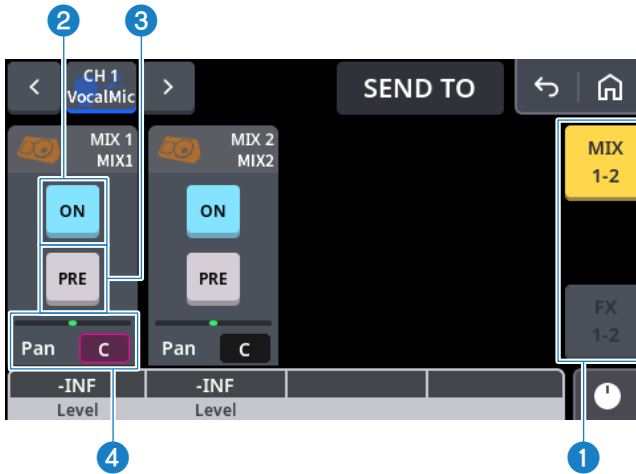

1 Send switch buttons (side menu)

Switches the send destination channels (buses) shown onscreen.

2 [ON] button

Switches the sends on/off.

3 [PRE] button

Switches the send point to the send destination channel to a prefader.

4 [Pan] slider

Sets the panning for the send. This can be shown/operated for mix buses whose bus type is VARI.

For MIX channels, an [ON] button is shown that sets the send from the MIX channel to the stereo bus on/off. The send point is fixed as post-fader.

Dedicated channel screen > SEND TO screen



Simple mode operation guide

How to access simple mode

- 1 Open the [SETUP] screen and touch [Operation Mode] at the top left of the screen.

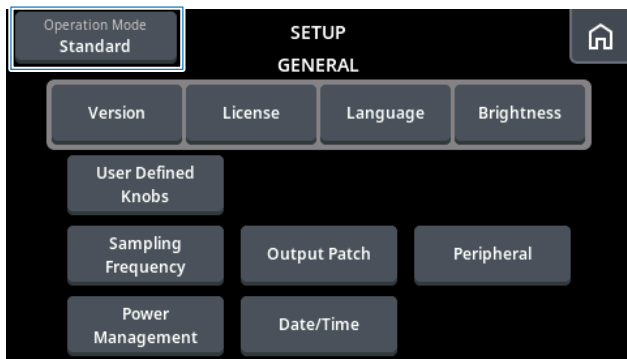

- 2 Select [Simple Mode] and touch [Next].



3 Select the mixer configuration method from the screen that's shown.

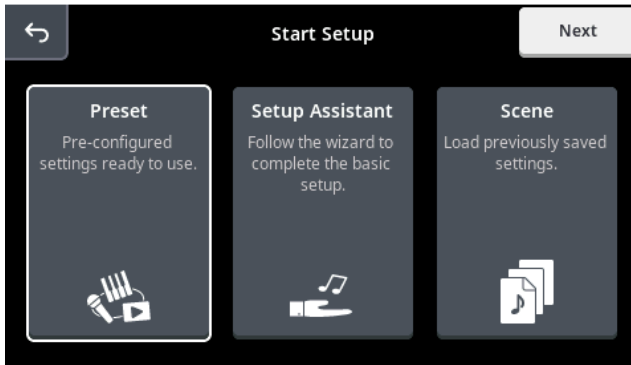

Preset: Allows quickly recalling default settings for specific use cases. This is useful when you want to start simple without making complex settings.

Setup Assistant: Allows connecting input devices, headphones, speakers, and other devices by following instructions displayed on the screen. This is recommended if you are using a mixer for the first time.

Scene: Allows recalling and using previously saved settings.

NOTE

For an overview of presets and use cases, refer to p.117.

4 Follow the onscreen instructions to proceed with the settings.

Select or input the necessary items on each screen and touch [Next] to go to the next step. The HOME (Overview) screen in Simple Mode is shown once you've finished with the settings.

■ Quick tour

In Simple Mode, a simple explanation (quick tour) of how to use the mixer screen is shown. The quick tour is shown every time you select “Setup Assistant” or “Preset”.



NOTE

It is not shown when you select “Scene”.

When you select [Don't show again] at the end of the quick tour, the quick tour does not appear again from the next time onward. To show the quick tour again, you must initialize the setting on the maintenance screen (p.165).

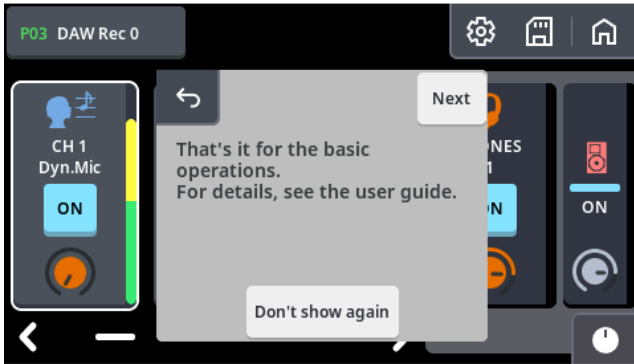

Selecting the presets and use cases

Selection menu screen

When you select “Preset” or “Setup Assistant” in “Start Setup”, a selection menu is shown for the presets or use cases. Refer to the next page for the explanation of each menu.

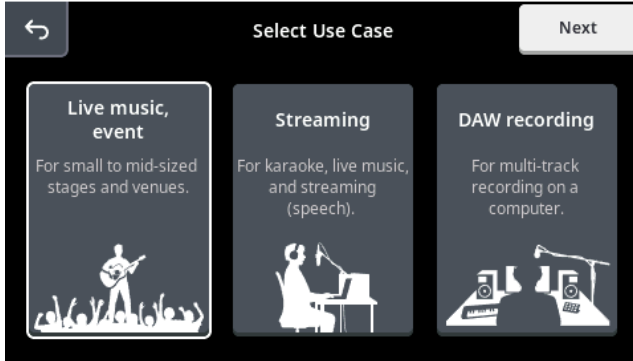

“Live music, event” overview

This setting is designed for small live performances at shops or similar venues, live music on small-scale stages, events held at venues or open spaces and so forth. This lets you make simple adjustments to the volume balance.

Mixer routing diagram

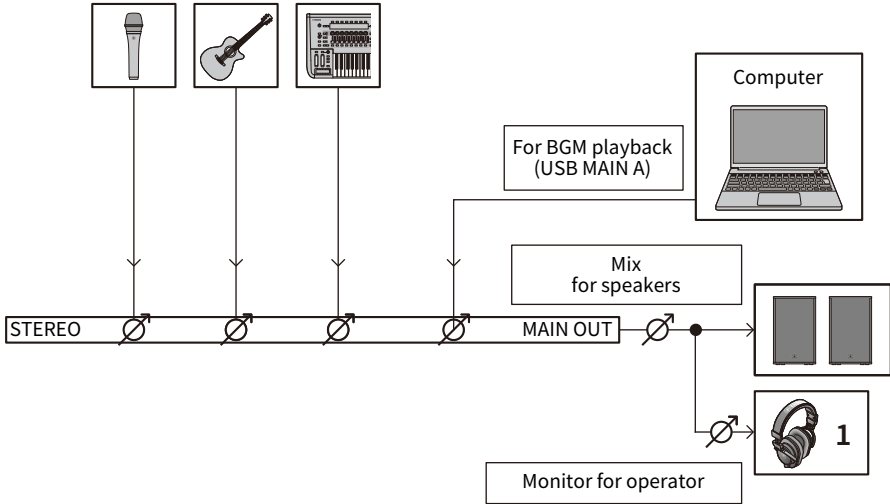

“Streaming” overview

This setting is designed for simple streaming done by a single person, such as karaoke, a performance on a musical instrument, a conversation and so forth. The person doing the streaming can adjust the volume balance between the streaming mix and the mix heard for monitoring in headphones.

Mixer routing diagram

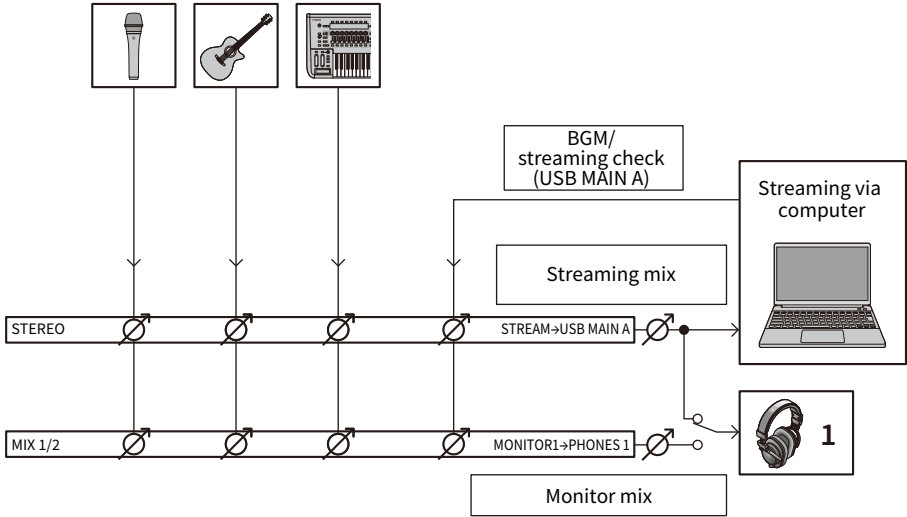

“DAW recording” overview

This setting is designed for easy multitrack recording using a DAW. The audio from a mic, guitar or other instrument can be monitored in headphones and recorded to your DAW. Further, you can output the playback sound from the DAW to speakers for checking the results of your recording, editing and mixing. The mixer routing is shown in the diagram below.

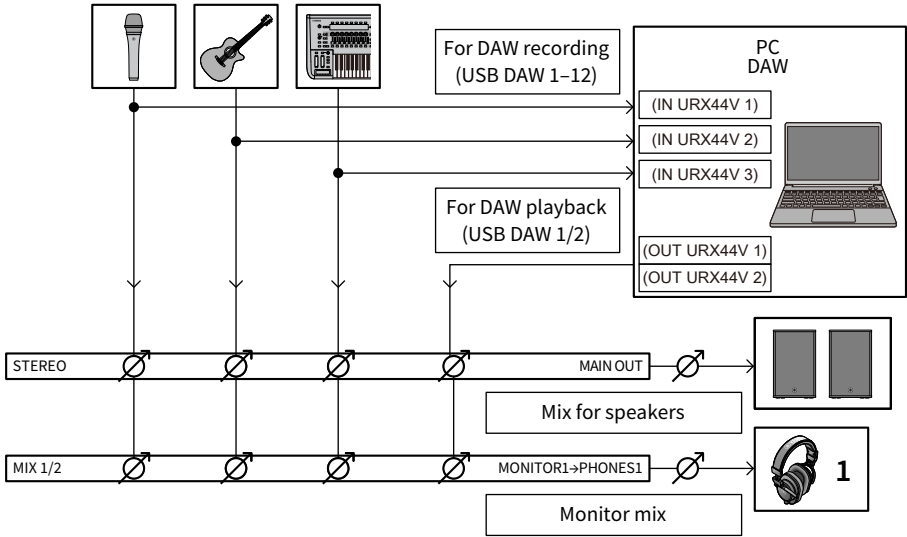



Simple mode screens

HOME (Overview) screen layout



Toolbar



- 1 Displays the [SCENE] screen (p.71).
- 2 Displays the [SETUP] (settings) screen (p.51).
- 3 Shows the [microSD] screen.  /  is displayed while playing back or recording microSD data (p.75).
- 4 Accesses the [HOME] screen from various other screens.

Input area



Touch the buttons aside from the ON button or the level knobs to select them. Touching a selected channel again shows the “Channel view screen” (p.128).

■ Channel view

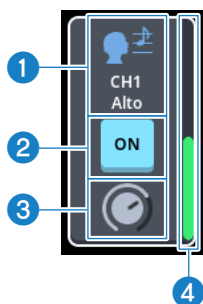

1 Channel name area

Shows the name of the selected channel. You can't change the names when in Simple Mode.

2 ON button

Turns the channel on/off.

3 Level knob

Control the channel's level from the multi-function knob below the display.

4 Input meter

Shows the level for the channel directly after input.

Stereo channels are shown with a stereo meter.

NOTE

- Channels that are specified in the setup assistant as having no input are disabled. Touch the “+” button to bring up the setup assistant again.



- The channel view is not displayed for the FX1 channel even if the corresponding area is touched.

■ Channel display selector



Press the “<” and “>” buttons to switch between the display input channels, three at a time.

NOTE

- You can also switch between channels by swiping the display section left or right on the input channel.
- The input channel display can also be switched by pressing each button for “-----”.

Mix selection and output area

■ Mix selection

This selects the mix used for adjusting the volume balance. The mix that's being adjusted is shown on the left.

Touch the mix shown at right to swap the mixes.

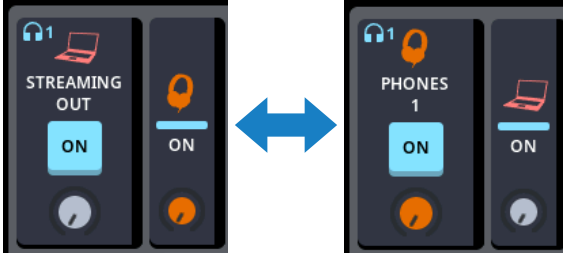

NOTE

If you've selected "Live music, event", only one mix can be used, so only the mix being adjusted is shown.

■ Output area

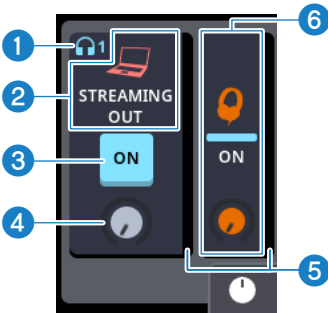

1 icon

Indicates that the mix being adjusted is being monitored in [PHONES] 1.

2 **Output destination icon/port name**

Shows the icon for the output destination port and the port name.

3 **ON button**

Turns the audio output on/off.

4 Level knob

Adjust the output level with the multi-function knob below the display.
The specified output level is displayed.

5 Output meter

Shows the output level after adjusting the volume.

6 Mix selection for adjustment

Selects the mix for adjusting volume balance. Touch this area to switch mixes, with the target mix for volume balance adjustment shown larger. The mix marked “PHONES1” is monitored as PHONES1.

This displays the output port icon, on/off indicator, output level, and output meter.

Multi-function knob toggle button

To adjust the “PHONES 1” volume, touch this button and operate the targeted parameter.



NOTE

If the USER DEFINED KNOBS mode is on for the multi-function knobs, the **4** level knob cannot be operated.

Example of parameter operation: “Streaming” use case

To control the parameters for STREAMING OUT and PHONES 1, touch the mix in the output area to switch to it.

■ When the [STREAMING OUT] mix is selected

This adjusts the volume balance of STREAMING OUT by operating the multi-function knobs corresponding to respective input channels.



■ When the [PHONES 1] mix is selected

This adjusts the volume balance of PHONES 1 by operating the multi-function knobs corresponding to respective input channels. When the level knobs for each channel are orange, this indicates that the volume balance of the PHONES 1 mix is being adjusted.



NOTE

The volume balance between the STREAMING OUT mix for streaming and the PHONES 1 mix for monitoring in headphones can each be adjusted flexibly. For example, if you want to stream karaoke, you can adjust the volume so that the CH1 mic input audio for the STREAMING OUT mix is louder and the PHONES 1 mix is quieter.

Channel view screen

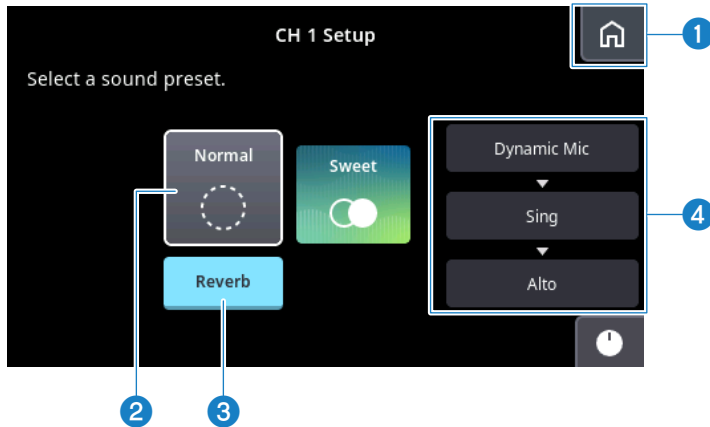

1  **(HOME) button**

Returns to the HOME (Overview) screen in simple mode.

2 **Main area**

Selects a sound while audio is being input. You can swipe the icon to change the sound. A white border is shown for the selected sound.

NOTE

- The audio changes depending on the selected values in the 4 channel setting area, even for the same sound.
- In DAW mode, only the [Dry] sound is available, so that the inputted audio can be sent to the DAW as-is. The reverb button will be disabled.

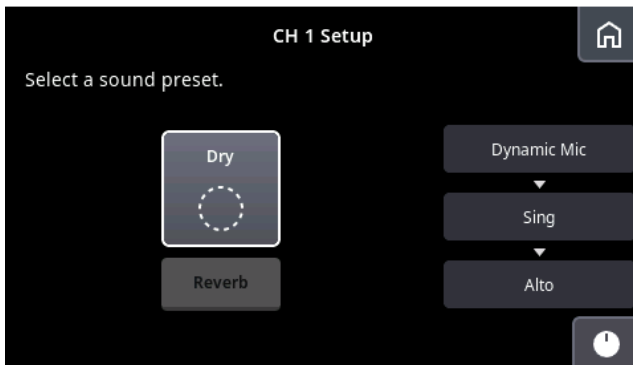

3 **[Reverb] button**

Switches the reverb on/off. Light blue is the “on” setting.

NOTE

- The overall reverb level is adjusted using the multi-function knob while [FX 1 Reverb] is selected on the Simple Mode HOME (Overview) screen (p.121).
- The reverb may automatically turn on, depending on the sound that's selected.

4 Channel setting area

A screen for reconfiguring the settings for connecting and using the unit is shown when you touch each button.

Screen example

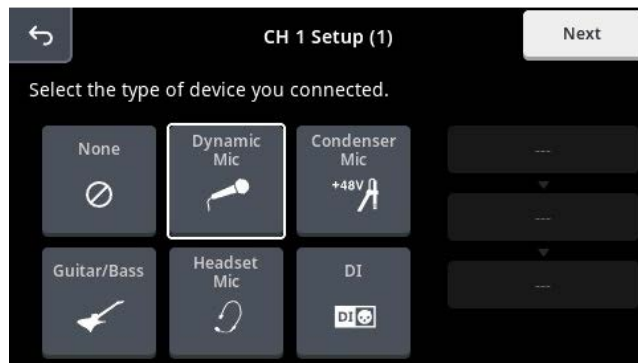

Sound-related operations

Operating the gate from the HOME screen (Overview)

- 1 From the Overview screen, select the channel for which you want to set the gate, and touch the channel indicator area to switch to channel view.**
- 2 Touch the [GATE] button to switch the gate on.**
- 3 To adjust the gate values, touch the [GATE] area and configure the settings in the GATE screen that's shown.**

Related links

["GATE screen" \(p.99\)](#)

Operating the compressor from the HOME screen (Overview)

- 1 From the Overview screen, select the channel for which you want to set the compressor, and touch the channel indicator area to switch to channel view.**
- 2 Touch the [COMP] button to switch the compressor on.**
- 3 To adjust the compressor values, touch the [COMP] area and configure the settings in the COMP screen that's shown.**

Related links

["COMP screen" \(p.100\)](#)

Operating the gain from the HOME screen (Overview)

- 1 From the Overview screen, select the channel for which you want to set the gain, and touch the channel indicator area to switch to channel view.**
- 2 This selects the INPUT (input) area.**
- 3 On the input area screen that's shown, use the [A.Gain]/[D.Gain] knob to adjust the gain value.**

Related links

"INPUT screen" (p.96)

Operating the EQ from the HOME screen (Overview)

- 1 From the Overview screen, select the channel for which you want to set the EQ, and touch the channel indicator area to switch to channel view.**
- 2 Touch the [EQ] button to switch the EQ on.**
- 3 To adjust the EQ values, touch the EQ graph area and configure the settings in the EQ screen that's shown.**

Related links

"EQ screen" (p.102)

Operating the insert from the HOME screen (Overview)

- 1 From the Overview screen, select the channel for which you want to set the effect, and touch the channel indicator area to switch to channel view.**
- 2 Touch INS FX area in the toolbar to display the INS FX screen.**
- 3 Touch the Effect menu popup button to show the effect selection screen, and select the effect you want to insert.**
- 4 To control the effect parameters, touch the effect area and configure the parameters in the parameter settings screen.**

Refer to the “Effect List” for the effects you can insert.

Related links

- “Effect list” (p.180)
- “INS FX screen” (p.109)

Operating the SSMCS from the HOME screen (Overview)

- 1 From the Overview screen, select the channel for which you want to set the SSMCS, and touch the channel indicator area to switch to channel view.**

NOTE

If SSMCS is not displayed, touch the channel settings screen display button in the upper right of the screen. When the channel settings screen is displayed, change the [COMP/EQ] setting from [COMP->EQ] to [SSMCS]. Touch the “Back” button to return to channel view.

- 2 Touch the [SSMCS] button to switch the SSMCS on.**
- 3 To adjust the SSMCS values, touch the SSMCS area and configure the settings in the SSMCS screen that's shown.**

Related links

- “SSMCS (Sweet Spot Morphing Channel Strip) screen” (p.104)
- “Channel settings screen” (p.95)

Operating the ducker from the HOME screen (Overview)

- 1 From the Overview screen, select the channel for which you want to set the ducker, and touch the channel indicator area to switch to channel view.**
- 2 Touch the [DUCKER] button to switch the DUCKER on.**
- 3 To adjust the DUCKER values, touch the DUCKER area and configure the settings in the DUCKER screen that's shown.**

Related links

[“DUCKER screen” \(p.110\)](#)

Operating the delay from the HOME screen (Overview)

- 1 On the Overview screen, select the STREAMING channel and touch the channel indicator area to enable the channel view.**
- 2 Touch the [DELAY] button to switch the DELAY on.**
- 3 To adjust the DELAY values, touch the DELAY area and configure the settings in the DELAY screen that's shown.**

Related links

[“DELAY screen” \(p.111\)](#)

SEND TO settings

- 1 From the Overview screen, select the channel for which you want to set the SEND TO, and touch the channel indicator area to switch to channel view.**
- 2 Touch the [SEND TO] button to configure the settings in the SEND TO screen that's shown.**

Related links

[“SEND TO screen” \(p.112\)](#)

Other operations

Storing a scene

- 1 From the SCENE screen → [Scene List] , select the (slot of the) number you want to save.**
- 2 Touch the [Store] button to show the scene title input screen.**
- 3 Input the desired title name on the screen that's shown, and touch the [OK] button.**
- 4 Once the confirmation screen appears, touch the [OK] button to store the scene.**

Related links

[“SCENE screen” \(p.71\)](#)

Recalling a scene

- 1** From the **SCENE** screen → scene list, select the (slot of the) number you want to recall.
- 2** Touch the **[Recall]** button to recall the scene.

Related links

[“SCENE screen” \(p.71\)](#)

Deleting a scene

- 1** From the **SCENE** screen → scene list, select the (slot of the) number you want to delete.
- 2** Select **[Edit]** from the side menu.
- 3** From the scene list, select the (slot of the) number you want to delete.
- 4** Touch the  button and tap **[OK]** on the dialog box that's shown to delete the scene.

Related links

[“SCENE screen” \(p.71\)](#)

Changing the scene title

- 1** From the **SCENE** screen → scene list, select the (slot of the) number you want to edit.
- 2** Select **[Edit]** from the side menu.
- 3** From the scene list, select the (slot of the) number you want to edit.
- 4** Touch the  button. After inputting the new title name on the screen that's shown, tap the **[OK]** button to change the title.

Related links

[“SCENE screen” \(p.71\)](#)

Recording to a microSD card (URX44V, URX44)

- 1 From the toolbar, touch  and touch [Recorder] on the screen that's shown.**
- 2 Touch [Source] in the list that's shown to select the source you want to record for each channel.**
- 3 Touch the [REC] button to set the unit to record standby mode. The [REC] button flashes when the unit is in record standby mode.**
- 4 Touch the [Play/Pause] button to start recording. The recording time is shown and the counter advances during recording.**
- 5 To stop recording, touch the [Stop] button. A filename is automatically given to the data that you record.**

NOTE

Touch the [Play/Pause] button during recording if you wish to pause recording. The [Play/Pause] button lights up red while the unit is paused.

Related links

“microSD screen (URX44V, URX44)” (p.75)

Playing back audio recorded on a microSD card (URX44V, URX44)

- 1** From the toolbar, touch  and touch [Recorder] on the screen that's shown.
- 2** Touch [Play] in the side menu.
- 3** Select the file you want to play from the list of files that can be played back.
- 4** Touch the [Play/Pause] button to play back the file.

NOTE

- Pressing the [TOUCH AND TURN] knob and selecting a different file during playback will stop the file that's playing back. The file you selected starts playing after that.
- Each time you press the knob while the file that's playing back is selected, the operation repeatedly switches between playback and pause.

Related links

"microSD screen (URX44V, URX44)" (p.75)

Using the monitor function

- 1** Connect the monitor system to the **OUTPUT** connectors on the rear panel.
- 2** Touch  on the toolbar, and operate from the [Monitor] menu on the [MONITOR] screen.
- 3** From [Setting] in the submenu, select the monitor source from Source.
- 4** To enable the monitor function, touch the [ON] button.
- 5** Turn the knob to adjust the monitor level.

Related links

“Monitor menu” (p.66)

Using the PHONES

- 1 Touch  on the toolbar, and operate from the [Phones] menu on the [MONITOR] screen.**
- 2 Check the PHONES source via MONITOR 1 and 2.**

The PHONES source signal is output from MONITOR 1 and 2.
- 3 Turn the knob to adjust the monitor level.**

Related links

“Phones menu” (p.68)

Using the oscillator

Use this for checking the output of your speakers or when performing a line check.

1 Touch  on the toolbar, and operate from the [Oscillator] menu on the MONITOR screen.

2 Select the playback mode in Oscillator Mode.

You can set the frequency and so on, depending on the mode.

NOTE

For the oscillator output destination, you can assign the desired channel from [Assign] in the submenu.

3 Touch the [ON] button to begin output.

4 Turn the knob to adjust the oscillator level.

Related links

“Oscillator menu” (p.69)

Using the cue function

This explains how to use the [CUE] button in the HOME screen (Overview) or the dedicated channel screen to monitor the cue signal.

- 1 From [Setting] in the [Monitor] menu, turn “CUE Interruption” on.**
- 2 Touch the [CUE] button in the HOME screen (Overview) or the dedicated channel screen to turn [CUE] on.**

NOTE

When [CUE] is on in the HOME screen (Overview), the CUE indicator appears, and the CUE bus meter is shown. When you touch the meter area at this time, all of the [CUE] can be turned off.

Related links

- “HOME screen (Overview)” (p.44)
- “Monitor menu” (p.66)

Assigning functions to the user defined knobs

- 1** Touch  in the toolbar and touch [USER DEFINED KNOBS] in the menu that's shown.
- 2** Touch the bank number you want to set from [Bank].
- 3** When the knob ID (A-D) of the bank you selected is shown, touch the knob ID you want to set.

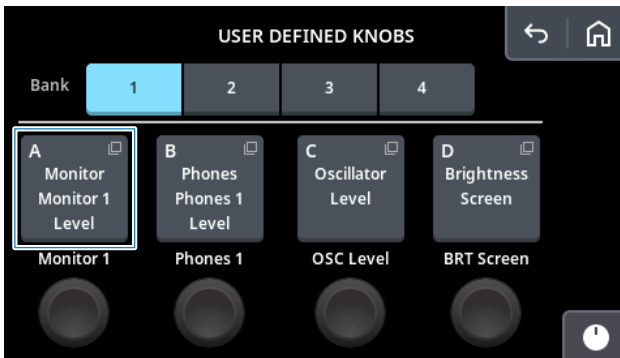

- 4 Select the function to assign from the screen that's shown. Once you've finished making the settings, touch the [OK] button to close the dialog box.**

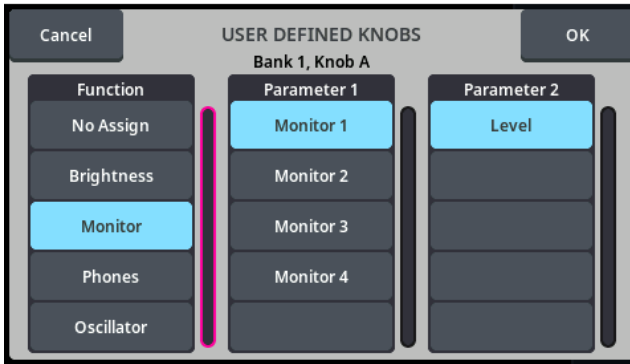

Abbreviations of the selected Function names and Parameter names are shown at the bottom of the screen when the USER DEFINED KNOBS mode is turned on.



- 5 Follow the same steps to set the functions for knobs ID (B–D).**

Updating the firmware

1 Make sure that this product is connected via USB cable to a computer that has TOOLS for MGX/URX installed.

2 That displays the Device Center device list screen.

To update the firmware for the interface unit, use the Device Center device configuration software. Device Center is included in TOOLS for MGX/URX.

Use the following steps to launch Device Center and access the Device List screen.

- Windows: Launch Device Center from the notification area on the taskbar

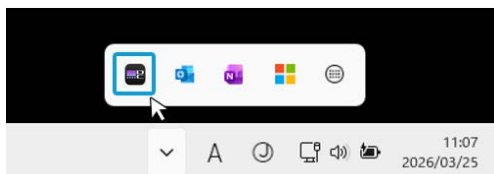

- Mac: In the Applications folder, launch Device Center.

3 On the Device Center Device List screen, select the URX device for which firmware is to be updated.

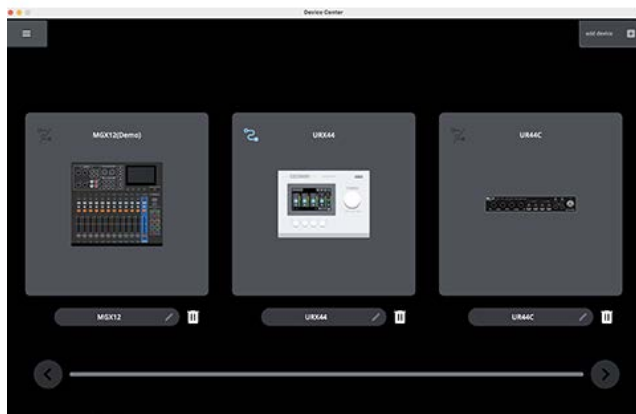

4 Disconnect all Yamaha products other than the selected URX from your computer.

5 Click [] (Firmware Update).

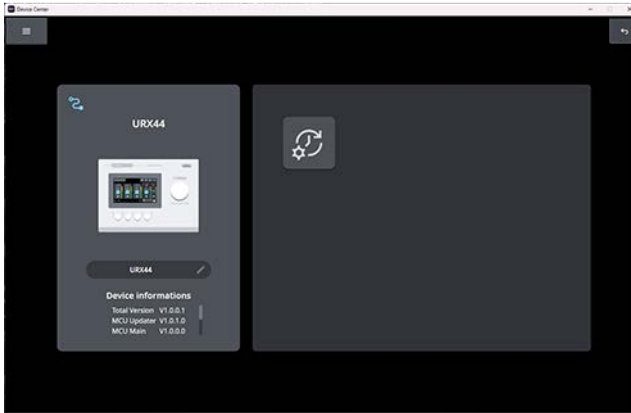

6 Follow the onscreen instructions to update the firmware.

7 When the screen indicating the update is complete appears, click [Close].

Now you're finished with the firmware update.

Using the Software Integration functions (V1.2 and later)

Getting ready (DAW Integration)

DAW Integration is a function for controlling this product via software, including input/output to or from DAW software and linking the routing. Software that is compatible with DAW Integration includes Steinberg Cubase, Nuendo and MixKey. By using this function, you can use hardware mixing to create a comfortable monitoring environment that's free from latency.

To use the DAW Integration function, you must prepare the following three items, as necessary.

- **Installing TOOLS for MGX/URX** (p.20)

TOOLS for MGX/URX V1.1.0 or later must be installed. If the currently installed version is old, install the latest version.

- **Update this product's firmware** (p.151)

Update the firmware to the latest version.

- **Install compatible software**

Install Steinberg Cubase, Nuendo or MixKey on a computer that contains an installation of TOOLS for MGX/URX V1.1.0 or later. Visit the following websites for information on the respective software titles.

- Cubase/Nuendo: <https://www.yamaha.com/2/urx-software-1/>
- MixKey: <https://www.steinberg.net/mixkey/>

Steps for configuring DAW Integration

- 1 Connect a computer on which compatible software is installed to the [USB MAIN] port of this unit.**
- 2 Launch the compatible software.**

This unit and the software will be linked together, and the DAW Integration screen appears.



- 3 Operate the software to configure this unit.**

See “Using in tandem with a DAW” (p.156) for how to configure the settings using the software and for the linkage function.

NOTE

About the **DAW Integration** operating limitations

In contrast with Standard Mode, the following functions are mainly unavailable.

- Stereo bus, STEREO channel
- SCENE (scene) functions
- microSD recorder functions
- When direct monitoring for the compatible software is on: the send signal to the MIX bus from the channel targeted for MONO IN is controlled via software. The following screen is shown on the unit, and operations are unavailable.



■ About the signal flow when DAW Integration is operating

The signals from the DAW software are directly connected to the MIX bus and FX bus. The input sources for each channel cannot be used to select USB DAW.

Refer to the “Block diagram” (p.186) to see which bus the signal names that are visible from the DAW app are connected to.

■ Canceling DAW Integration

DAW Integration is automatically canceled when quitting the software or when the connection with the computer has been interrupted. When this happens, the unit returns to Standard Mode.

Using in tandem with a DAW

Dedicated screens for the Cubase Series

These screens are for configuring the settings of this unit using the Cubase Series. There are two screens, an input settings screen and a hardware settings screen.

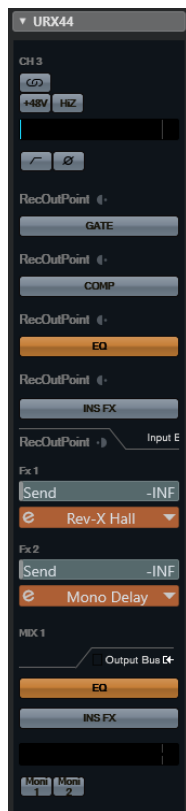

Input settings screen

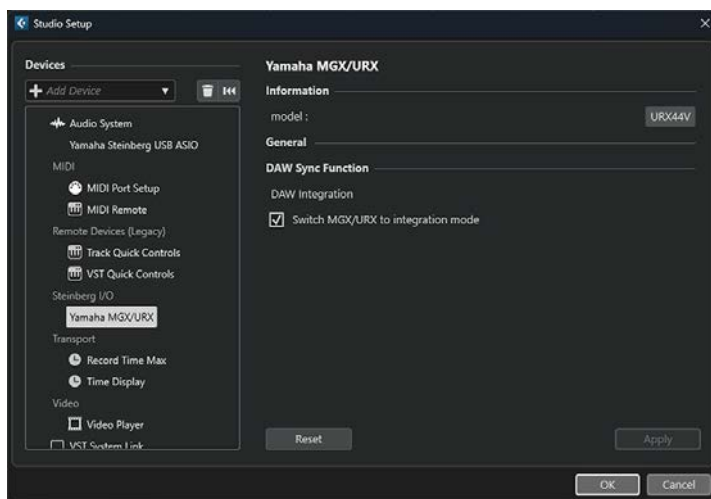

Hardware settings screen

How to open the screens

Input settings screen

From the Cubase Series menu, create an audio track from [Project] → [Add Track] → [Audio], and click the [URXxxx] tab that's shown in the inspector on the left side of the screen ("xxx" indicates the model you are using).

Hardware settings screen

From the Cubase Series menu:

Open [Studio] → [Studio Setup], and select [Yamaha MGX/URX] from [Steinberg I/O] on the left side.

Input settings screen

Header area

This area shows the connected device names.



1 Model

Shows the name of the model (URXxxx) to be operated. Click to show/hide the input settings screen.

Hardware input settings area

This area is for configuring the parameters related to the inputs on this unit.

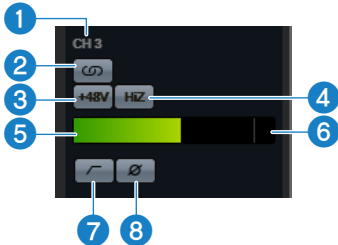

1 Port name

Shows the device port name for the input bus.

2 Stereo link

This lets you set operation modes for two adjacent channels (CH1/2, CH3/4, etc.). When this is on, the channels are stereo linked (STEREO), and when this is off, the channels are independent (MONO × 2).

3 +48V

Switches +48 V on/off.

4 HI-Z

Switches HI-Z on/off.

5 Input meter

Shows the input level.

6 Clip indicator

Lights up when the input signal is clipping. Click to turn the indicator off.

7 High-pass filter

Switches the HPF (high-pass filter) on/off.

8 Phase

Switches the signal phase inversion (180°) on/off. For stereo signals, "LR" is shown.

Channel strip setting area

This area is for configuring the parameters related to the channel strips (channel signal processing) on this unit.

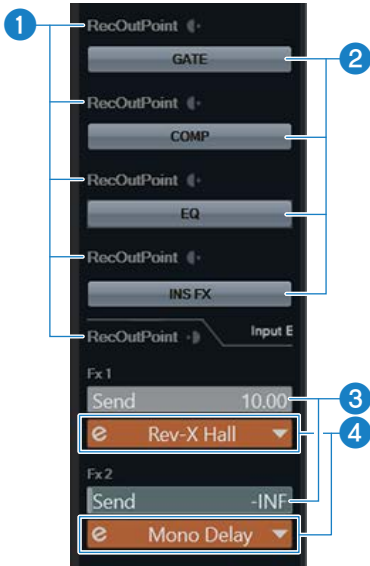

1 RecOutPoint

Selects the point within the signal path from which to directly record (extract) the signal of a channel. Click the icon to switch between extraction points.

2 GATE/COMP/EQ/SSMCS/INS FX

Switches the GATE, COMP, EQ, SSMCS, and INS FX on/off.

For COMP and EQ, the settings are shown when the COMP/EQ setting of this unit is COMP -> EQ.

For SSMCS, this is shown when the COMP/EQ settings on this unit are SSMCS.

3 FX1/FX2 send

Adjusts the amount of signal sent to FX1/FX2 (in other words, the amount of effects applied).

Range: -∞ dB to +10.00 dB

4 FX1/FX2 name

Shows the type name of the selected effect.

Using the Software Integration functions (V1.2 and later) > Using in tandem with a DAW

Output area

This area is for configuring the parameters related to the output channels on this unit.

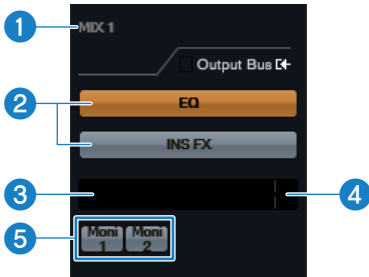

1 Mix Bus name

Shows the hardware mix bus for this unit. The output bus of the tracks must be connected to this mix bus.

2 EQ/INS FX

Switches the EQ and INS FX on/off.

3 Output meter

Shows the meter for the MIX channels on this unit to which the track output bus is connected.

4 Clip indicator

Lights up when the input signal is clipping. Click to turn the indicator off.

5 Monitor select button

Selects the monitor (1, 2) used for outputting the signal.

■ Direct monitoring function settings

By turning direct monitoring on, you can create a latency-free monitoring environment. Make the settings as follows.

Windows

From the Cubase Series menu, go to [Studio] → [Studio Setup] → [Yamaha Steinberg USB ASIO] → select the [Direct Monitoring] check box → [OK].

Mac

From the Cubase Series menu, go to [Studio] → [Studio Setup] → [Yamaha URXxxx DAW] or [Yamaha URXxxx DAW (High Precision)] → select the [Direct Monitoring] check box → [OK].

Hardware settings screen

This screen shows the information for the settings of this unit and the linkage function settings related to Cubase.

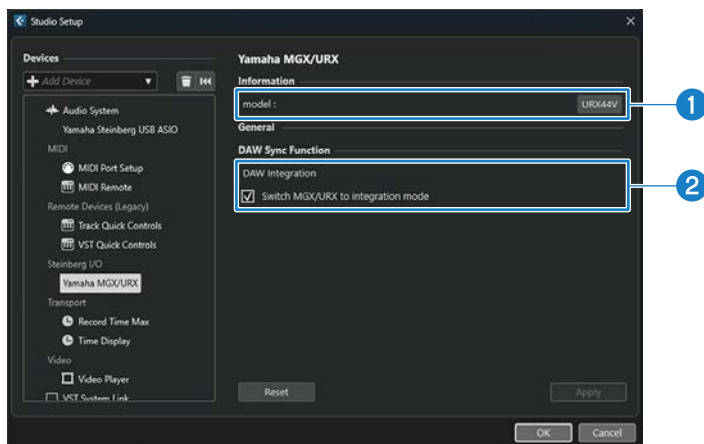

1 model

Shows the name of the connected model.

2 DAW Integration

If the check box is selected, the DAW Integration expanded functions are enabled. If the check box is not selected, the expanded functions are disabled, and the unit will not be linked with Cubase from the next time it starts up.

NOTE

See the Cubase Series Owner's Manual for other details on how to use the Cubase Series.

MixKey channel editor

By using the channel editor in the MixKey app, you can configure the parameters of this unit from the MixKey app.

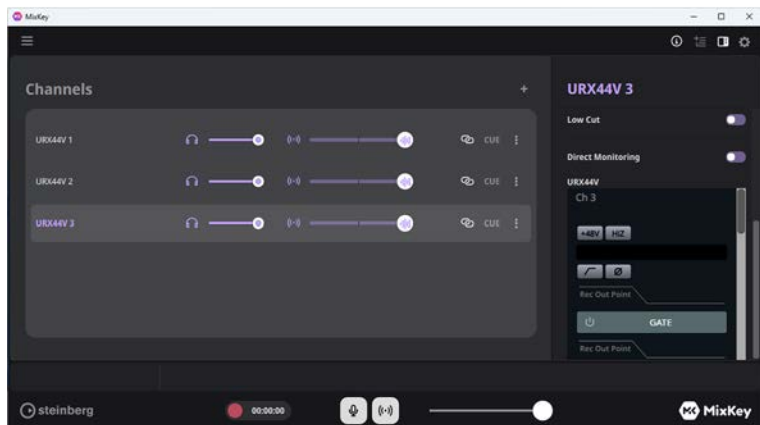

How to open the screens

1 Click  to open the mixer/settings screen.

2 From [Settings], click [Audio].

3 In [Audio System], select the driver as follows.

Windows

Select [Yamaha Steinberg USB ASIO]

Mac

Select [Yamaha URxxxx DAW] or [Yamaha URxxxx DAW (High Precision)]

4 In [MONITOR OUTPUT], select the port of the URX model for ASIO Output Devices.

5 Click  to close the mixer/settings screen.

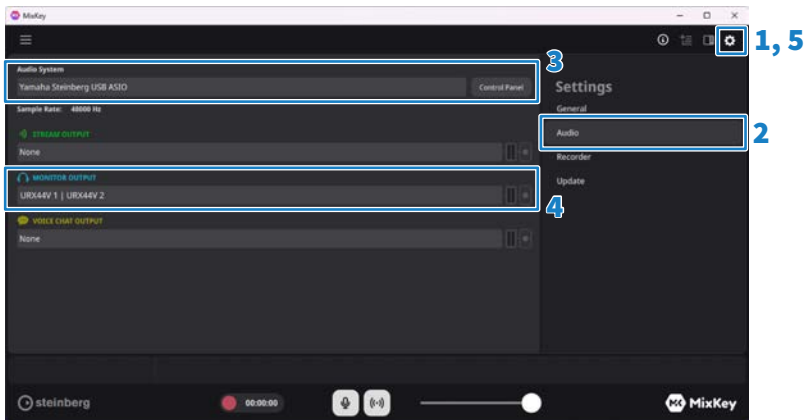

6 Click  to add the sound input source. In the source, select the port of the URX model from Yamaha Steinberg USB ASIO (Windows) or Yamaha URxxxx DAW/ Yamaha URxxxx DAW (High Precision) (Mac).

Using the Software Integration functions (V1.2 and later) > Using in tandem with a DAW

7 Click to open the channel editor.

The input settings screen appears below and to the right of the channel editor.

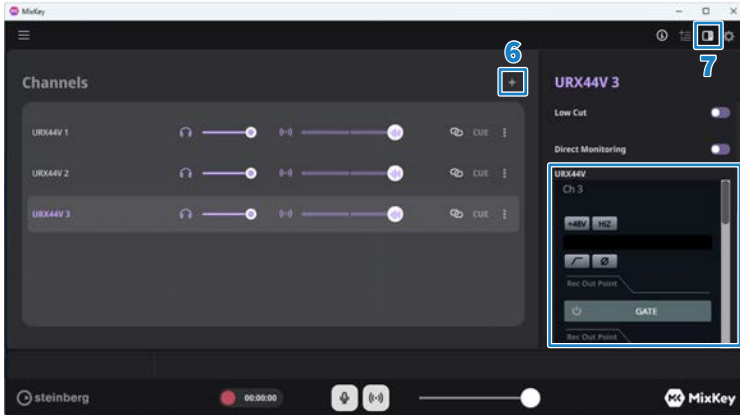

The settings screen that's shown is the same as the Cubase Series "Input settings screen" (p.158). There is no screen for the MixKey that corresponds to the Cubase Series hardware settings screen.

Restoring the factory settings

Initializing this unit

NOTE

Restoring factory settings will delete all data stored in the unit. Carefully consider whether to reset the settings before doing so.

- 1 With the rightmost multi-function knob pressed, turn on the power.**
- 2 Once the initialize screen is shown, select the menu to execute from the left side of the screen and touch the [Initialize] button.**

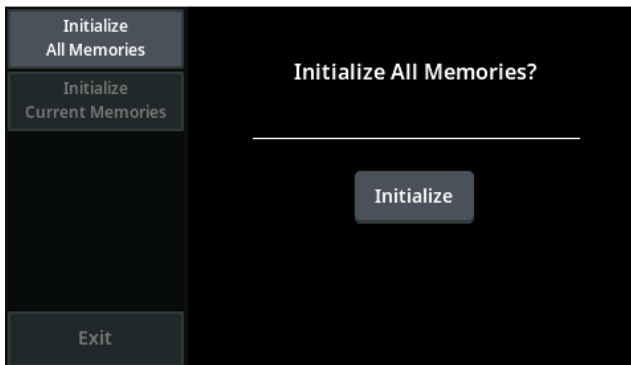

[Initialize All Memories]

This reverts the entire memory (including the scene memories) to the factory default settings.

[Initialize Current Memories]

This reverts the current memories (except for the scene memories) to their factory default settings.

- 3 Once the confirmation dialog box appears, touch [OK].**

This initializes the data.

Mounting the unit on a panel or stand

Installing the interface unit

Use the bolt holes in the bottom of the unit to fasten the unit to commercially available mounting hardware (such as a panel or stand). Reference the following documents when attaching mounting hardware.

NOTICE

- Tighten fasteners adequately to prevent loosening.

Bottom view

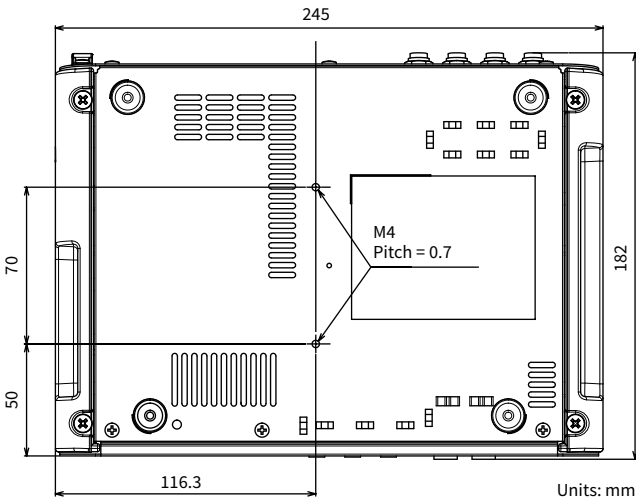

Installation example

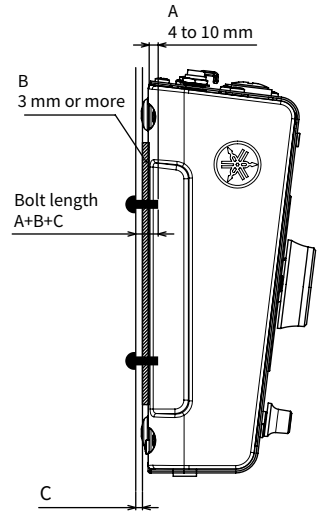

A: Depth screwed into product: 4 to 10 mm

B: Thickness of spacers for avoiding rubber feet and bolt protrusions: 3 mm or more

C: Thickness of mounting hardware

Frequently asked questions

Troubleshooting (audio)

No sound is heard

■ Connection-related causes

● The device connection may not be appropriate

Make sure that external devices such as mics, as well as monitor speakers are connected correctly.

● The cable may be damaged

Make sure that there are no shorts or breaks in the cables.

■ External device-related causes

● The monitor speakers may be off

Turn the monitor speakers on.

■ Causes related to this unit's settings

● The input/output signal settings may be inappropriate

In the "INPUT screen" (p.96)/"Output Patch menu" (p.58), check whether the input/output source is selected appropriately.

● Input gain may be too low

Adjust the gain on the "INPUT screen" (p.96).

● The [ON] button for the corresponding channel is set to off.

Press the [ON] key.

● Phantom power may be turned off

When using a condenser mic, set the [+48V] button on the "INPUT screen" (p.96) to on.

● Output level may be too low

Adjust the output level.

■ Computer/software-related causes

● No driver installed on the computer

Install TOOLS for MGX/URX from the Yamaha website listed below. The Yamaha Steinberg USB Driver will install automatically.

<https://www.yamaha.com/2/urx/>

● **Buffer size is too small**

Adjust the buffer size on the Yamaha Steinberg USB Driver settings screen.

How to open the settings screens

Windows

- From the Start menu: [Yamaha Steinberg USB Control Panel]
- From the Cubase Series menu: [Studio] → [Studio Setup] → [Yamaha Steinberg USB ASIO] → [Control Panel]

Mac

- From the Cubase Series menu: [Studio] → [Studio Setup] → [Yamaha URXxxx DAW] or [Yamaha URXxxx DAW (High Precision)] → [Control Panel]
(“xxx” indicates the name of the model you are using)

● **Audio settings on the DAW software may be inappropriate**

Check the audio settings on your DAW software.

For Cubase

From the Cubase Series menu, open [Studio] → [Studio Setup] → [Audio System], and check whether [Yamaha Steinberg USB ASIO] (Windows), [Yamaha URXxxx DAW] or [Yamaha URXxxx DAW (High Precision)] (Mac) is selected for the [ASIO Driver] on the right side.

(“xxx” indicates the name of the model you are using)

● **The input/output routing may be inappropriate**

Check the input/output settings on your DAW software.

For Cubase

Open [Studio] → [Audio Connections] to check the input/output settings.

● **The message Audio Format is Unmixable is shown (Mac only)**

If Cubase does not quit normally, the error message Audio Format is Unmixable is shown in the Yamaha Steinberg USB Driver control panel. When this happens, press [Revert to Mixable] to resolve the error.

● **Streaming software volume may be too low**

If you are using streaming software, adjust the volume in the software.

Sound is distorted

- **The levels on the devices connected to this unit may be too high**

Lower the output level of the connected devices.

- **The gain settings may be inappropriate**

Adjust the gain on the INPUT screen.

Troubleshooting (power supply)

■ Cannot turn on power (URX44, URX22)

● Computer power is not on

To operate the interface unit using USB bus power, turn on the computer power.

● The computer, USB power adapter, or USB mobile battery is not connected to the correct connector

- Connect the computer to the [USB MAIN] port.
- Connect the USB power adapter or USB mobile battery to the [5V DC IN] connector.

● An appropriate USB power adapter or USB mobile battery is not being used

Use a device with an output of 5 V DC (3A or more).

■ The power switches off (URX44V)

If no operations are performed for a specified period, the power is turned off automatically (default setting). The Auto Power Off setting can be changed via the “Power Management menu” (p.62).

Troubleshooting (other issues)

■ Display is too dim

Use the [Brightness] menu to adjust the Screen value.

■ microSD card recording date/time values are not set correctly (URX44V and URX44)

If the internal battery in the interface unit becomes depleted, the internal clock will stop, which results in incorrect microSD card recording date/time settings.

If a “Low Battery” or “No Battery” warning is displayed, contact the vendor where the product was purchased or a repair service center to request a clock battery replacement.

■ Cannot update the firmware

An error screen is shown if this unit fails to update. To retry the update, click the [Retry] button. To quit, click the [OK] button.

Appendix

Trademarks

USB Type-C™ and USB-C™ are trademarks of USB Implementers Forum.

Windows is a registered trademark of Microsoft Corporation in the United States and other countries.

Mac, macOS, iPad, iPhone, iPadOS, App Store, and Lightning are trademarks of Apple Inc. registered in the United States and other countries.

Android is a trademark of Google LLC.

Steinberg and Cubase are registered trademarks of Steinberg Media Technologies GmbH.



The terms HDMI, HDMI High-Definition Multimedia Interface, HDMI Trade dress and the HDMI Logos are trademarks or registered trademarks of HDMI Licensing Administrator, Inc.

MIDI is a registered trademark of the Association of Musical Electronics Industry (AMEI).

microSD and the microSD logo are trademarks of SD-3C, LLC.

The company names and product names in this manual are the trademarks or registered trademarks of their respective companies.

General specifications

		URX44V	URX44	URX22
Mixing capacity	Input channels	4 mono + 4 stereo + 2 FX		2 mono + 4 stereo + 2 FX
	Buses	2 MIX (Stereo) + 2 FX + 1 CUE + 1 STEREO		
Local connectors	Analog input	2 Mic/Line (2 XLR/TRS Phone Combo) 2 Mic/Line/HI-Z (2 XLR/TRS Phone Combo) 1 HEADSET MIC (3.5 mm Phone, plug-in power) (CH 1 MIC and HEADSET MIC cannot be used simultaneously) and 1 AUX (3.5 mm Phone)		1 Mic/Line (1 XLR/TRS Phone Combo) 1 Mic/Line/HI-Z (1 XLR/TRS Phone Combo) 1 HEADSET MIC (3.5 mm Phone, plugin power) (CH 1 MIC and HEADSET MIC cannot be used simultaneously) and 1 AUX (3.5 mm Phone)
	Analog output	4 Line (TRS Phone)		2 Line (TRS Phone)
	USB to HOST	2 (USB Type-C)		
	PHONES	3 (2 × Stereo Phone, 1 × 3.5mm) The PHONES 1 connector and 3.5 mm stereo headphones connector cannot be used simultaneously.		
	DC power input	1 (Barrel type)	1 (USB Type-C)	
	HDMI IN (URX44V)	1		
	HDMI THRU (URX44V)	1		
	SD card slot (URX44V, URX44)	1 microSD card slot		
User interface	Display	4.3-inch touch screen		
	Knobs	5 × Rotary Encoder (4 × screen knob, 1 × TOUCH AND TURN knob)		
Recording & playback	USB MAIN	Recording up to 18 tracks / Playback up to 18 tracks		Recording up to 16 tracks / Playback up to 16 tracks
	USB SUB	Recording 2 tracks / playback 2 tracks		
	microSD Card (URX44V, URX44)	Recording up to 16 tracks / Playback 2 tracks		
Sampling frequency	Frequency	44.1 kHz / 48 kHz / 88.2 kHz / 96 kHz / 176.4 kHz / 192 kHz		
	Accuracy	±50 ppm		
Power requirements		DC 16 V/2.4 A, PA-300 power adapter (100 V–240 V, 50 Hz/60 Hz)	5 V DC / 3 A via USB MAIN (bus power) or 5V DC IN (external power supply)	
Power consumption		38.4 W	15 W	
Power consumption when off		0.1 W		
Auto Power Off		Adjustable between 2 and 20 minutes.		
Dimensions (W × H × D)		245 mm × 78 mm × 182 mm		
Net weight		2.0 kg	1.9 kg	
Operating temperature range		0–40 °C		
Storage temperature range		–20–60 °C		

Appendix > General specifications

	URX44V	URX44	URX22
Included accessories	Start Guide × 1 Safety Guide × 1 Cubase AI License Card × 1 Steinberg Plus License Card × 1 Basic FX Suite License Card × 1 USB-C to USB-C cable (USB 3.2, 1 m long) × 1 Power adapter (PA-300 including power cord) × 1 Ferrite core × 1	Start Guide × 1 Safety Guide × 1 Cubase AI License Card × 1 Steinberg Plus License Card × 1 Basic FX Suite License Card × 1 USB-C to USB-C cable (USB 2.0, 1.5 m long) × 1	

Technical specifications

0 dBu = 0.775 Vrms, 0 dBV = 1.0 Vrms

URX44V, URX44

MIC INPUT 1-4 (balanced)	
Frequency response	+0.0/-0.2 dB, 20 Hz-20 kHz
Dynamic range	115 dB, A-Weighted
Total harmonic distortion	0.0008 %, 1 kHz, 20 kHz LPF
Max. input level	+16 dBu
Input impedance	4 k Ω
Gain range	78 dB (-8 dB-+70 dB)
Equivalent input noise	-128 dBu, A-Weighted

LINE INPUT 1-4 (balanced)	
Max. input level	+24 dBu
Input impedance	10 k Ω
Gain range	78 dB (-16 dB-+62 dB)

HI-Z INPUT (INPUT 3/4 unbalanced)	
Max. input level	+9 dBV
Input impedance	1 M Ω
Gain range	48 dB (-7.2 dB-+40.8 dB)

HEADSET MIC (unbalanced)	
Max. input level	-6 dBV
Input impedance	2.2 k Ω
Gain range	28 dB (+12 dB-+40 dB)

AUX L/R (unbalanced)	
Max. input level	0 dBV
Input impedance	10 k Ω

MAIN OUTPUT (balanced)

Frequency response	+0.0/-0.02 dB, 20 Hz–20 kHz
Dynamic range	125 dB, A-Weighted
Total harmonic distortion	0.00036 %, 1 kHz, 20 kHz LPF
Max. output level	+16 dBu
Output impedance	300 Ω

LINE OUTPUT (balanced impedance)

Frequency response	+0.0/-0.02 dB, 20 Hz–20 kHz
Dynamic range	118 dB, A-Weighted
Total harmonic distortion	0.0022 %, 1 kHz, 20 kHz LPF
Max. output level	+10 dBu
Output impedance	150 Ω

PHONES 1/2

Max. output level	100 mW + 100 mW, 40 Ω
Output impedance	10 Ω

Analog-digital converters (INPUT 1-4)

Dynamic range	120 dB, A-Weighted
Total harmonic distortion	-112 dB, A-Weighted

Digital-analog converter (MAIN OUTPUT)

Dynamic range	130 dB, A-Weighted
Total harmonic distortion	-120 dB, A-Weighted

XLR INPUT



Polarity

- 1: Ground
- 2: Hot (+)
- 3: Cold (-)

URX22

MIC INPUT 1/2 (balanced)	
Frequency response	+0.0/-0.2 dB, 20 Hz-20 kHz
Dynamic range	115 dB, A-Weighted
Total harmonic distortion	0.0008 %, 1 kHz, 20 kHz LPF
Max. input level	+16 dBu
Input impedance	4 k Ω
Gain range	78 dB (-8 dB-+70 dB)
Equivalent input noise	-128 dBu, A-Weighted

LINE INPUT 1/2 (balanced)	
Max. input level	+24 dBu
Input impedance	10 k Ω
Gain range	78 dB (-16 dB-+62 dB)

HI-Z INPUT (INPUT 2 unbalanced)	
Max. input level	+9 dBV
Input impedance	1 M Ω
Gain range	48 dB (-7.2 dB-+40.8 dB)

HEADSET MIC (unbalanced)	
Max. input level	-6 dBV
Input impedance	2.2 k Ω
Gain range	28 dB (+12 dB-+40 dB)

AUX L/R (unbalanced)	
Max. input level	0 dBV
Input impedance	10 k Ω

MAIN OUTPUT (balanced)	
Frequency response	+0.0/-0.02 dB, 20 Hz-20 kHz
Dynamic range	125 dB, A-Weighted
Total harmonic distortion	0.00036 %, 1 kHz, 20 kHz LPF
Max. output level	+16 dBu
Output impedance	300 Ω

PHONES 1/2

Max. output level	100 mW + 100 mW, 40 Ω
Output impedance	10 Ω

Analog-digital converters (INPUT 1/2)

Dynamic range	120 dB, A-Weighted
Total harmonic distortion	-112 dB, A-Weighted

Digital-analog converter (MAIN OUTPUT)

Dynamic range	130 dB, A-Weighted
Total harmonic distortion	-120 dB, A-Weighted

XLR INPUT



Polarity

- 1: Ground
- 2: Hot (+)
- 3: Cold (-)

■ Digital Input/Output Characteristics

Terminal	Format	Data Length	Standard	Audio	Connectors
USB to Host [MAIN]	PCM	32-bit / Up to 192 kHz	Yamaha Steinberg USB Driver	URX44V, URX44: Up to 18 in / 18 out URX22: Up to 16 in / 16 out	USB (Type-C, USB 2.0: High Speed)
		32-bit / Up to 192 kHz	USB Audio Class (UAC 2.0)	URX44V, URX44: 14 in / 12 out URX22: 12 in / 10 out	
USB to Host [SUB]	PCM	16-bit / 48 kHz	USB Audio Class (UAC 1.0)	2 in / 2 out	USB (Type-C, USB 2.0: Full Speed)
microSD Card Slot (URX44V, URX44)	WAV	24-bit / Up to 192 kHz	microSDHC/ microSDXC (UHS-I or higher, Class 10 or higher), exFAT supported	Recording: 16 tracks @ 44.1/48 kHz 8 tracks @ 88.2/96 kHz 2 tracks @ 176.4/192 kHz Playback: 2 tracks	microSD Card Slot
HDMI IN (URX44V)	PCM	Up to 24-bit / 192 kHz	HDMI, HDCP	8 in	HDMI (Type A)
HDMI THRU (pass-through) (URX44V)	PCM	Up to 24-bit / 48 kHz	HDMI, HDCP	2 out	HDMI (Type A)

Audio signals input from HDMI and USB SUB are automatically converted to the audio format of this unit.

■ Video input/output standard (URX44V)

Terminal	Resolution	Standard	Feature	Connectors
HDMI IN	Up to 4K60, 1440p120, 1080p240	HDMI, HDCP	HDR10, HLG, VRR	HDMI (Type A)
HDMI THRU (pass-through)	Up to 4K60, 1440p120, 1080p240	HDMI, HDCP	HDR10, HLG, VRR	HDMI (Type A)
USB to HOST [MAIN]	Up to 4K60, 1440p120, 1080p240	USB Video Class (UVC 1.1) ^{*1}	HDR10, HLG	USB (Type-C, USB 3.2 Gen1, 5 Gbps)

*1 Driver installation is unnecessary for Windows and macOS.

The contents of this guide apply to the latest specifications as of the publishing date.

Effect list

COMPANDER-H, COMPANDER-S

Supported sampling frequencies	44.1 kHz, 48 kHz, 88.2 kHz, 96 kHz
Supported channels	Can be used with the INS FX of both the MONO IN channels and the output channels. When Signal Type is inserted into a stereo channel pair, it operates in stereo. Note that this cannot be inserted into two mono channels.
Number of simultaneous uses	MONO IN channels: 1 slot; output channels: 1 slot Note that this cannot be used at the same time as the MULTI-BAND COMPRESSOR.

MULTI-BAND COMPRESSOR

Supported sampling frequencies	44.1 kHz, 48 kHz, 88.2 kHz, 96 kHz
Supported channels	Can be used with the INS FX of the output channels. When Signal Type is inserted into a stereo channel pair, it operates in stereo. Note that this cannot be inserted into two mono channels.
Number of simultaneous uses	1 slot Note that this cannot be used at the same time as the COMPANDER-H and COMPANDER-S.

PITCH FIX

Supported sampling frequencies	44.1 kHz, 48 kHz
Supported channels	Can be used with the INS FX of the MONO IN channels. Cannot be used when Signal Type is stereo.
Number of simultaneous uses	1 slot

GUITAR AMP CLASSICS (Clean, Crunch, Lead, Drive)

Supported sampling frequencies	44.1 kHz, 48 kHz, 88.2 kHz, 96 kHz
Supported channels	Can be used with the INS FX of the MONO IN channels. Cannot be used when Signal Type is stereo.
Number of simultaneous uses	1 slot

REV-X (HALL/ROOM/PLATE)

Supported sampling frequencies	44.1 kHz, 48 kHz, 88.2 kHz, 96 kHz, 176.4 kHz, 192 kHz
Supported channels	Can be used with FX1 Note that this cannot be used at the same time as the MONO DELAY and PING PONG DELAY.

REV-R3 (HALL/ROOM/PLATE)

Supported sampling frequencies	44.1 kHz, 48 kHz, 88.2 kHz, 96 kHz
Supported channels	Can be used with FX2 Note that this cannot be used at the same time as the MONO DELAY and PING PONG DELAY.

MONO DELAY

Supported sampling frequencies	[FX1]:44.1 kHz, 48 kHz, 88.2 kHz, 96 kHz, 176.4 kHz, 192 kHz [FX2]: 44.1 kHz, 48 kHz, 88.2 kHz, 96 kHz
Supported channels	Can be used with FX1 and FX2. With the FX1, this cannot be used at the same time as the REV-X and the PING PONG DELAY. With the FX2, this cannot be used at the same time as the REV-R3 and the PING PONG DELAY.

PING PONG DELAY

Supported sampling frequencies	[FX1]:44.1 kHz, 48 kHz, 88.2 kHz, 96 kHz, 176.4 kHz, 192 kHz [FX2]: 44.1 kHz, 48 kHz, 88.2 kHz, 96 kHz
Supported channels	Can be used with FX1 and FX2. With the FX1, this cannot be used at the same time as the REV-X and the MONO DELAY. With the FX2, this cannot be used at the same time as the REV-R3 and the MONO DELAY.

Functions that can be assigned to the user defined knobs

The functions that can be assigned to the user defined knobs are as follows.

Function	Parameter 1	Parameter 2	
		URX44V, URX44	URX22
No Assign	---	---	---
Brightness	Screen	---	---
Monitor	Monitor 1-2	Level	Level
Phones	Phones 1-2	Level	Level
Oscillator	Level	---	---

USB MAIN signal name reference table

Windows

Usable regions				URX44V, URX44 (44.1 kHz, 48 kHz, 88.2 kHz, 96 kHz)	URX22 (44.1 kHz, 48 kHz, 88.2 kHz, 96 kHz)	URX44V, URX44 (176.4 kHz, 192 kHz) URX22 (176.4 kHz, 192 kHz)
Output signal name on computer	A Yamaha URX**	B Yamaha URX**	C Yamaha URX**	URX** 1–12	URX** 1–10	URX** 1–4
	Recognized by computer as a sound output device			Used in the DAW or other software as Yamaha Steinberg USB ASIO device		
Input signal name for interface unit	USB MAIN A	USB MAIN B	USB MAIN C	USB DAW 1–12	USB DAW 1–10	USB DAW 1–4
Output signal name for interface unit	USB MAIN A	USB MAIN B	USB MAIN C	(CH 1–12 Rec Out)	(CH 1–10 Rec Out)	(CH 1–4 Rec Out)
Input signal name on computer	A Yamaha URX**	B Yamaha URX**	C Yamaha URX**	URX** 1–12	URX** 1–10	URX** 1–4
	Recognized by computer as a sound output device			Used in the DAW or other software as Yamaha Steinberg USB ASIO device		

Enter the model name (44V, 44, or 22) instead of the double-asterisks.

Mac

Usable regions				URX44V, URX44 (44.1 kHz, 48 kHz, 88.2 kHz, 96 kHz)	URX22 (44.1 kHz, 48 kHz, 88.2 kHz, 96 kHz)	URX44V, URX44 (176.4 kHz, 192 kHz) URX22 (176.4 kHz, 192 kHz)	
Output signal name on computer	Yamaha URX** A		Yamaha URX** B		Yamaha URX**C		Yamaha URX** DAW
	URX** A L	URX** A R	URX**B L	URX**B R	URX** C L	URX**C R	URX** 1–12 URX** 1–10 URX** 1–4
Input signal name for interface unit	USB MAIN A	USB MAIN B	USB MAIN C	USB DAW 1–12	USB DAW 1–10	USB DAW 1–4	
Output signal name for interface unit	USB MAIN A	USB MAIN B	USB MAIN C	(CH 1–12 Rec Out)	(CH 1–10 Rec Out)	(CH 1–4 Rec Out)	
Input signal name on computer	Yamaha URX** A		Yamaha URX** B		Yamaha URX** C		Yamaha URX** DAW
	URX** A L	URX** A R	URX**B L	URX**B R	URX** C L	URX**C R	URX** 1–12 URX** 1–10 URX** 1–4

Enter the model name (44V, 44, or 22) instead of the double-asterisks.

iPad/iPhone (URX44V, URX44)

When Generic Driver Audio Channel Suppression = None

Output signal on device	-	-	-	CH 1-12
Input signal name on this unit	USB MAIN A	USB MAIN B	USB MAIN C	USB DAW 1-12
Output signal name on this unit	USB MAIN A	USB MAIN B	USB MAIN C	(CH 1-12 Rec Out)
Input signal on device	CH 13, 14	-	-	CH 1-12

When Generic Driver Audio Channel Suppression = 2 Channels

Output signal on device	CH 1, 2	-	-	-
Input signal name on this unit	USB MAIN A	USB MAIN B	USB MAIN C	USB DAW 1-12
Output signal name on this unit	USB MAIN A	USB MAIN B	USB MAIN C	(CH 1-12 Rec Out)
Input signal on device	CH 1, 2	-	-	-

iPad/iPhone (URX22)

When Generic Driver Audio Channel Suppression = None

Output signal on device	-	-	-	CH 1-10
Input signal name on this unit	USB MAIN A	USB MAIN B	USB MAIN C	USB DAW 1-10
Output signal name on this unit	USB MAIN A	USB MAIN B	USB MAIN C	(CH 1-10 Rec Out)
Input signal on device	CH 11, 12	-	-	CH 1-10

When Generic Driver Audio Channel Suppression = 2 Channels

Output signal on device	CH 1, 2	-	-	-
Input signal name on this unit	USB MAIN A	USB MAIN B	USB MAIN C	USB DAW 1-10
Output signal name on this unit	USB MAIN A	USB MAIN B	USB MAIN C	(CH 1-10 Rec Out)
Input signal on device	CH 1, 2	-	-	-

Dimensions

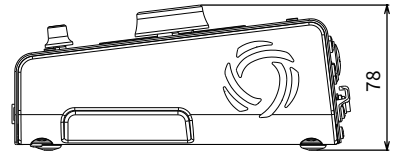
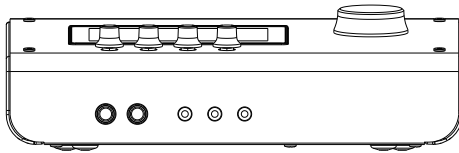
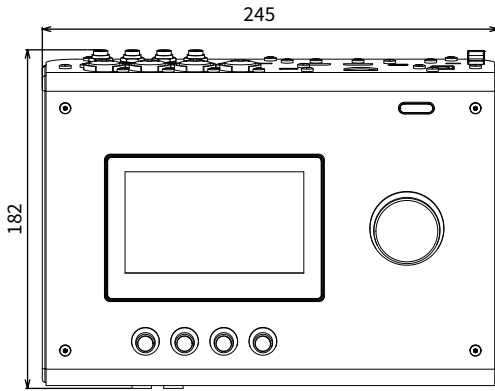

Units: mm

The URX44V is shown in the illustration.

Block diagram

For block diagrams of URX series models, refer to the following Yamaha website.

<https://www.yamaha.com/2/urx/>

Yamaha Global Site
<https://www.yamaha.com/>

Yamaha Downloads
<https://download.yamaha.com/>

© 2025 Yamaha Corporation

Published 04/2026 AM-C0