

YAMAHA KX-W10

Natural Sound Stereo Double Cassette Deck

Platine à double cassette stéréo de la série "Natural Sound"

"Natural Sound" Stereo-Doppelkassettengerät

Natural Sound stereokassettdäck

Registratore a doppia cassette stereo a suono naturale

Magnetófono estéreo de dos de sonido natural

Stereo-cassettedeck voor een "natuurlijk geluid"

0E

OWNER'S MANUAL
MODE D'EMPLOI
BEDIENUNGSANLEITUNG
BRUKSANVISNING
MANUALE DI ISTRUZIONI
MANUAL DE INSTRUCCIONES
GEBRUIKSAANWIJZING

1. This unit is a sophisticated stereo cassette deck. To ensure proper operation for the best possible performance, please read this manual carefully.
2. Choose the installation location of your unit carefully. Avoid placing it in direct sunlight or close to source of heat. Also avoid locations subject to vibration and excessive dust, heat, cold or moisture. Keep it away from sources of hum such as transformers or motors.
3. Do not open the cabinet as this may result in damage to the deck or electrical shock. If a foreign object should get into the deck, contact your local dealer.
4. When removing the power plug from the wall outlet, always pull directly on the plug; never pull the cord itself.
5. Do not apply excessive force when operating switches and knobs.
6. When moving the deck, be sure to first pull out the power plug and remove all cords connecting the deck to other equipments.
7. Do not attempt to clean this unit with chemical solvents as this may damage the finish. Use a clean, dry cloth.
8. Never allow metallic items (e.g. screwdrivers, tools, etc.) to come near the record/playback head assembly. Doing so may not only scratch or damage the head's mirror-smooth finish, but also change the magnetic characteristics of the heads, causing a deterioration in reproduction quality.
9. Although the record/playback head used in this unit is a high quality head with outstanding reproduction characteristics, it can become dirty through the use of old tapes or from dust accumulation over time. This can have a serious effect on reproduction quality. Clean the heads regularly with one of the commonly available head cleaners or with cleaning solutions as explained later in this manual.
10. Be sure to read the "Troubleshooting" section of this manual for advice on common operating errors before concluding that your unit is faulty.
11. Keep this manual in a safe place for future reference.
12. **Voltage Selector (General Model only)**
The voltage selector on the rear panel of this unit must be set for your local mains voltage **BEFORE** plugging in the AC mains supply.

Please check the copyright laws in your country to record from records, compact discs, radio, etc. Recording of copyright material may infringe copyright laws.

WARNING

TO REDUCE THE RISK OF FIRE OR ELECTRIC SHOCK, DO NOT EXPOSE THIS APPLIANCE TO RAIN OR MOISTURE.

For U.K. customers

If the socket outlets in the home are not suitable for the plug supplied with this appliance, it should be cut off and an appropriate 3 pin plug fitted. For details, refer to the instructions described below.

Note: The plug severed from the mains lead must be destroyed, as a plug with bared flexible cord is hazardous if engaged in a live socket outlet.

Special Instructions for U.K. Model

IMPORTANT

The wires in the mains lead are colored in accordance with the following code:

Blue: NEUTRAL

Brown: LIVE

As the colors of the wires in the mains lead of this apparatus may not correspond with the colored markings indentifying the terminals in your plug, proceed as follows. The wire which is colored BLUE must be connected the terminal which is marked with the letter N or colored BLACK. The wire which is colored BROWN must be connected to the terminals which is marked with the letter L or colored RED. Making sure that neither core is connected to the earth terminal of the three pin plug.

FEATURES	3	DUBBING	12
CONNECTIONS	4	TIMER RECORDING	13
PLAYBACK	5	TIMER RECORDING	13
SELECTION SEARCH	7	TIMER PLAYBACK	13
RELAY PLAYBACK	7	CASSETTE TAPES	14
RECORDING	8	MAINTENANCE	15
SYNCHRONIZED RECORDING FUNCTION	10	REMOTE CONTROL TRANSMITTER	15
AUTO REC MUTE OPERATION	10	TROUBLESHOOTING	16
REC RETURN OPERATION	10	SPECIFICATIONS	17
VARIOUS FUNCTIONS HELPFUL			
FOR HIGH QUALITY RECORDING	10		
RELAY RECORDING	11		
DUAL RECORDING	11		

FEATURES

Hard Permalloy Heads in Both DECKs (recording/
 playback)
 Dolby HX Pro Dynamic Bias Servo
 Dolby B/C Noise Reduction
 Auto Tape Selector
 Relay Playback from DECK A to DECK B
 Play Trim Control for Improved Playback Compatibility
 with Other Decks
 Selection Search

Recording Mute Function
 Rec Return
 Relay Recording
 Dual Recording
 Easy Dubbing Operation at Selectable Speed (Normal/
 High)
 Peak Level Meters (with peak hold function)
 Electronic Tape Counter
 Integrated System Remote Control Compatibility

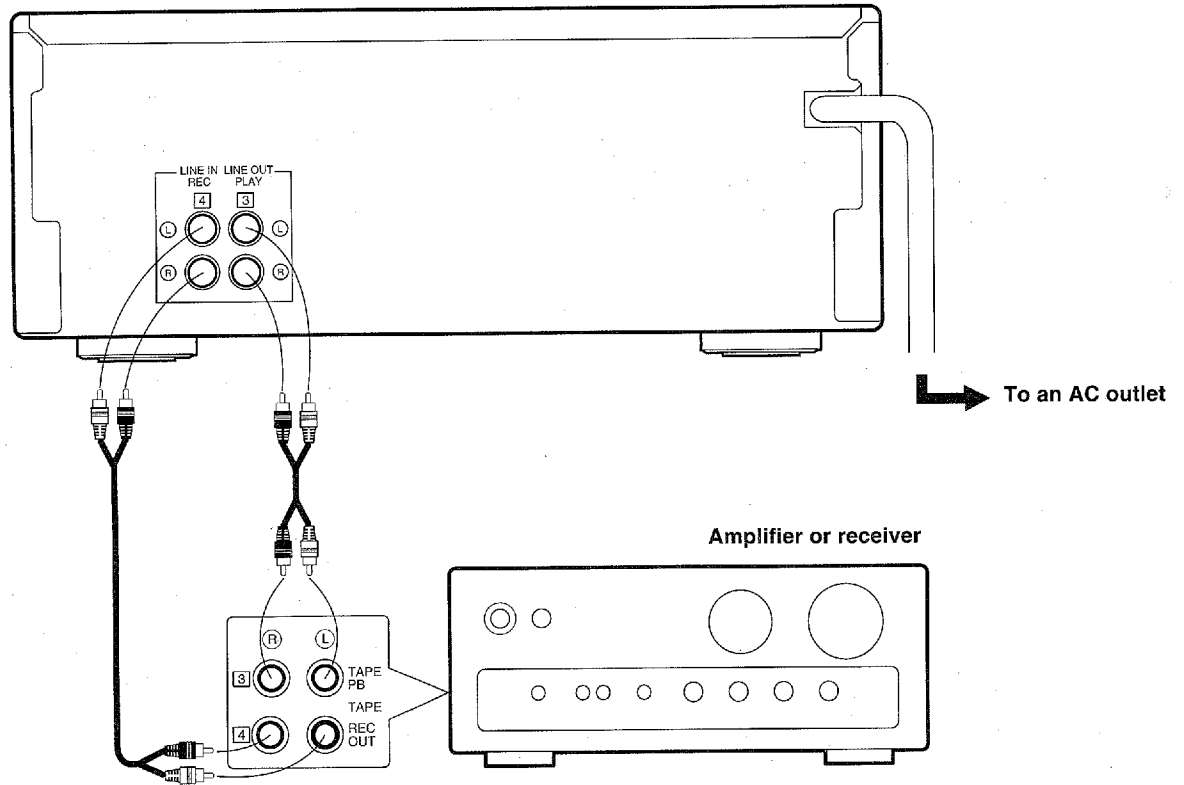

REAR PANEL CONNECTIONS

Make sure that power to both the deck and your amplifier/receiver are turned off before making any connection.

- The White plug on the paired connecting cables corresponds to the Left channel and the Red plug corresponds to the Right channel. Make sure that the left and right channel connections are properly made, and that the plugs are inserted firmly.
- The LINE OUT/PLAY jacks on the deck should be connected to the Tape PB (Playback/Input) jacks on your amplifier/receiver, and the LINE IN/REC jacks on the deck should be connected to the REC OUT (Recording/Output) jacks on your amplifier/receiver.
When using the amplifier AX-10/receiver RX-10, connect them referring to the numbers 3 and 4 on both units.
- Connect the power cord to an AC wall outlet or to an AC outlet on the rear panel of your amplifier/receiver (if provided).

Preparation for playback

Turn on the POWER switch.

Set your amplifier to cassette deck function mode.

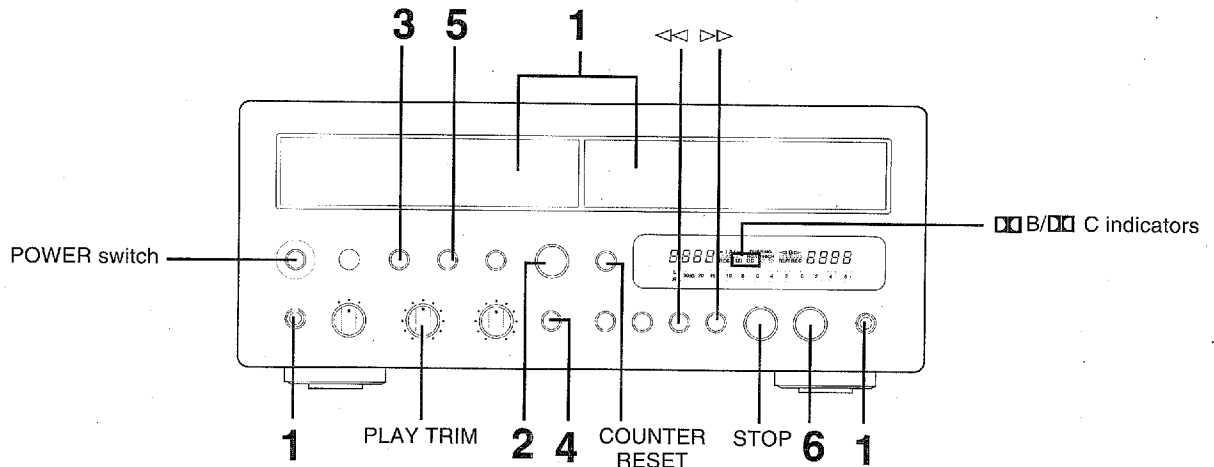

<p>1</p> <p>Place the cassette on the cassette tray with the exposed tape side facing back side of the unit. When setting the side to be played facing up, select forward tape running direction (▷) (in step 4). To load the cassette tray, press the button.</p> <ul style="list-style-type: none"> ● Make sure that the tape is wound to the right-hand reel with the cassette placed on the tray. 	<p>2</p> <p>DECK A/B</p> <p>Press the DECK A/B button to select the deck to be operated. The corresponding indicator lights on the display.</p>	<p>3</p> <p>DOLBY NR OFF/ON</p> <p>Set the DOLBY NR button. Refer to "DOLBY NR button setting".</p>	<p>4</p> <p>DIRECTION</p> <p>Select the tape running direction for DECK A or B. Each time this button is pressed, the tape running direction changes between forward (▷) and reverse (◁), and the corresponding indicator lights on the display.</p>	<p>5</p> <p>REVERSE MODE</p> <p>Set the REVERSE MODE button. Refer to "REVERSE MODE selector setting".</p>	<p>6</p> <p>PLAY</p>
--	--	--	---	---	-----------------------------

DOLBY NR button setting (in step 3)

Be sure to set the DOLBY NR button according to the system used for recording. Each time this button is pressed, Dolby NR switches as follows:

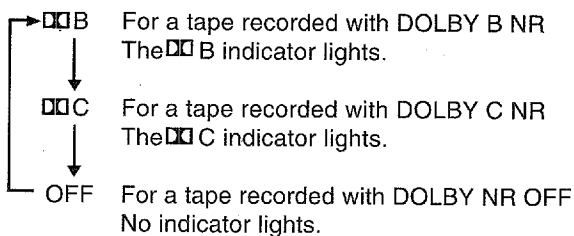

* Dolby noise reduction manufactured under license from Dolby Laboratories Licensing Corporation. "DOLBY" and the double-D symbol are trademarks of Dolby Laboratories Licensing Corporation.

To fast forward the tape

When the ▷ tape running indicator is lit, press the ▷▷ button.

When the ◁ tape running indicator is lit, press the ◁◁ button.

To fast rewind the tape

When the ▷ tape running indicator is lit, press the ◁◁ button.

When the ◁ tape running indicator is lit, press the ▷▷ button.

To adjust the volume level

Use the volume control of the amplifier.

To stop playback and remove the cassette tape

Press the STOP button and then the button. The cassette tray comes out and you can remove the cassette tape.

To turn off the power

Press the POWER switch again.

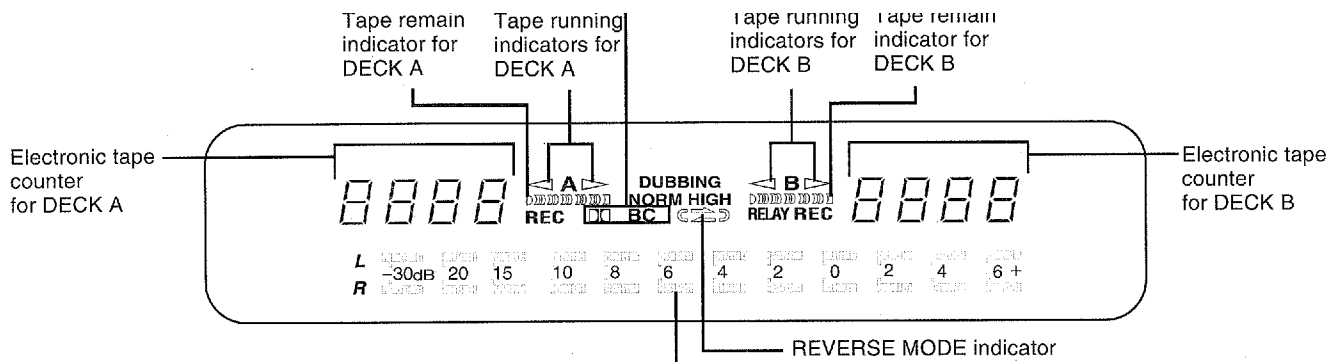

Peak level meters:
Indicate the peaks of the signal levels during recording and playback over a -30 dB to +6 dB range. There are separate meters for each left and right channel. These level meters have a peak hold function which holds the peak level for about 1.5 seconds. (The peak hold function works in the level from -10 dB to +6 dB.)

REVERSE MODE selector setting (in step 5)

The auto reverse function allows the tape running direction be reversed automatically. Select an auto reverse mode (▷◁, ◁▷, or ↔ RELAY) or manual reverse mode (⇄).

⇄: When playback or fast forwarding (or rewinding) of one side of a tape is finished, the deck stops at the end of the tape.

▷◁: Both sides of the tape are played back. After playing, the deck stops at the end of the tape. (When the tape running direction is set to ◁, only the reverse side is played.) When the tape is fast rewound to the beginning of the reverse side, playback automatically starts from the same side.

When the tape is fast forwarded to the end of the forward side, playback automatically starts from the reverse side.

◁▷: Both sides of the tape are repeatedly played back (up to 8 times).

When the tape is fast forwarded or rewound to the beginning or the end of a side, playback automatically starts from the same side or the other side respectively.

↔ RELAY: Cassette tapes loaded in DECKS A and B are played back sequentially. If a cassette tape is loaded in either one of the DECK A or DECK B, the tape is played back in the same way as the ◁▷ mode. (See "RELAY PLAYBACK" on page 7.)

Tape remain indicator

Regardless of the tape running direction, the tape remain indicator shows the remaining length of the loaded tape to be played back. It will be indicated after a few seconds when the loaded tape is forwarded.

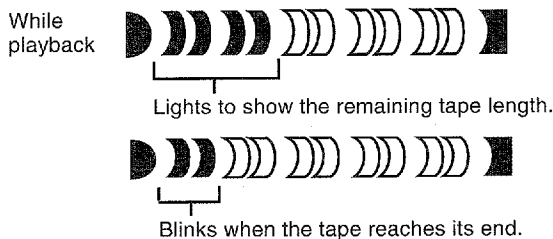

Note:

The tape remain indicator may differ depending on the tape length, tape type or the size of hub. So, use this indicator as an aid to recognize the remaining length of the tape to be played back.

Electronic tape counter

Use the electronic tape counter to aid in locating a point on a tape (0000 to 9999). To set the counter reading to "0000", press the COUNTER RESET button.

PLAY TRIM control adjustment

When distortion or the absence of high frequencies is noticeable while playing a tape recorded on another cassette deck, compensate the high frequency response with the PLAY TRIM control.

When high frequencies are too loud, attenuate the high frequencies.



When high frequencies are too soft, boost the high frequencies.

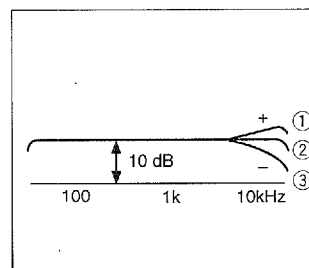

- ① High frequency sound is too boosted.
- ② Flat
- ③ High-frequency sound is absent.

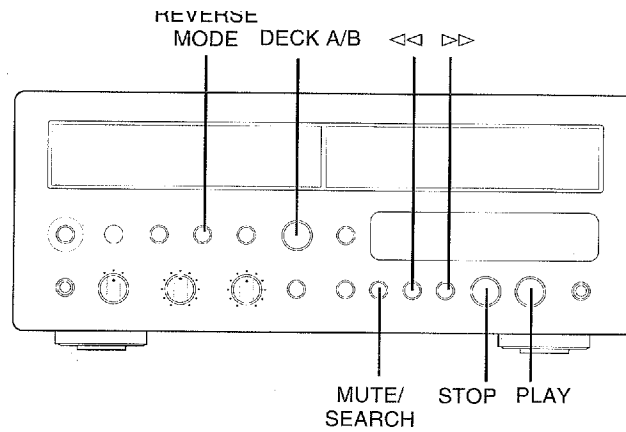

SELECTION SEARCH — To play back a desired selection by searching for the beginning of the selection

To search for the next selection

When the ▷ tape running indicator is lit:

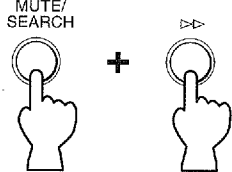

The <<>> buttons and the MUTE/SEARCH button should be pressed simultaneously.

When the < tape running indicator is lit:

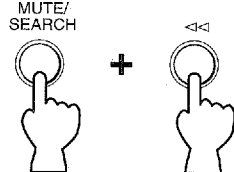

To search for the beginning of the current selection or the selection located before the current selection

When the ▷ tape running indicator is lit:

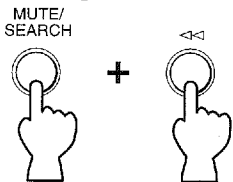

The <<< buttons and the MUTE/SEARCH button should be pressed simultaneously.

When the < tape running indicator is lit:

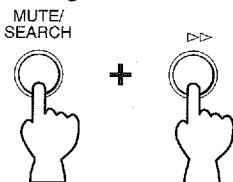

Notes on Selection search

- The blank section between selections must be at least 4 seconds.
- With tapes recorded with low level or fade-in or fade-out function, or with tapes having excessive noise, selection search may not be carried out.

RELAY PLAYBACK — To play DECK A and DECK B sequentially

Load the cassette tapes into DECKS A and B, and set the REVERSE MODE button to the ⇄ RELAY mode. Start playback of DECK A.

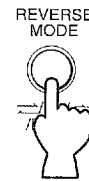

The ⇄ RELAY indicator will be lit, and relay playback mode starts.

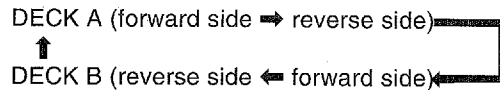

Up to 8 times

- The setting of Dolby NR for DECK B will be the same as that set for DECK A.

Press the STOP button to stop the relay playback before playback is repeated 8 times and stops automatically.

To switch the playback deck

Press the DECK A/B button to select the deck which is not played and press the PLAY button. The deck currently playing stops, and the other deck starts playback. The ⇄ RELAY mode goes on.

To fast forward/rewind the tape

Press the DECK A/B button to select the deck to be operated, and use the <<< and >>> buttons (Refer to page 5 for forward/rewind tapes).

To stop the ⇄ RELAY mode

Press the REVERSE MODE button, and turn off the ⇄ RELAY indicator.

RECORDING (Common to DECKS A and B)

Preparation for recording

- Turn on the POWER switch.
- Set your amplifier to cassette deck function mode.

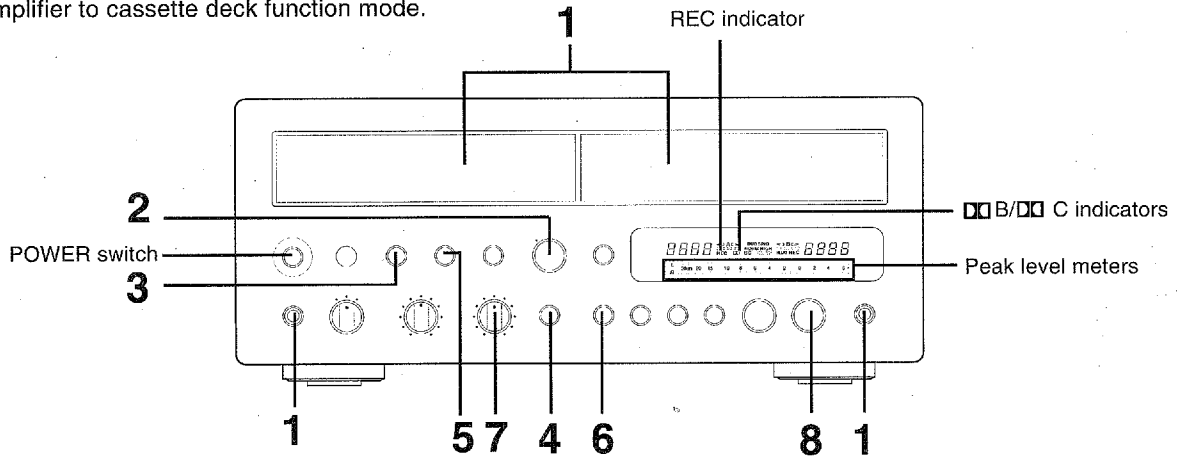

<p>1</p> <p>Place the cassette on the cassette tray with the exposed tape side facing back side of the unit. When setting the side to be recorded facing up, select forward tape running direction (▷) (in step 4). To load the cassette tray, press the button.</p>	<p>2</p> <p>DECK A/B</p> <p>Press the DECK A/B button to select the deck to be operated. The corresponding indicator lights on the display. When the following procedures are carried out for both decks, the program source can be recorded onto both decks. At that time, the stop, rec-pause and the rec return functions are carried out for each deck.</p>	<p>3</p> <p>DOLBY NR OFF/PAUSE</p> <p>Set the DOLBY NR button. Refer to "DOLBY NR button setting".</p>	<p>4</p> <p>DIRECTION</p> <p>Select the tape running direction for DECK A or B. Each time this button is pressed, the tape running direction changes between forward (▷) and reverse (◁), and the corresponding indicator lights on the display.</p>
<p>5</p> <p>REVERSE MODE</p> <p>Refer to "REVERSE MODE selector setting" on next page.</p>	<p>6</p> <p>REC/PAUSE</p> <p>The REC indicator lights on the display. The deck enters the rec pause mode.</p>	<p>7</p> <p>REC LEVEL</p> <p>0 10</p> <p>Play the program source to be recorded and adjust the recording level. See "Setting the recording level".</p>	<p>8</p> <p>PLAY</p>

DOLBY NR button setting (in step 3)

Dolby noise reduction is an extremely effective method of reducing undesirable background hiss on tapes. This unit incorporates both Dolby B NR and the newer Dolby C NR system. Dolby C NR is approximately twice as effective as the earlier Dolby B NR.

Each time this button is pressed, Dolby NR switches as follows:

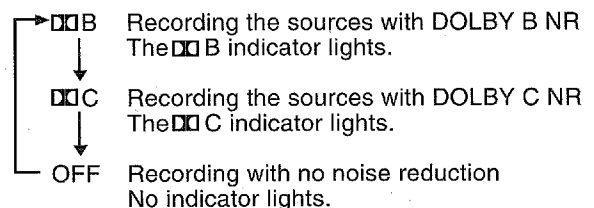

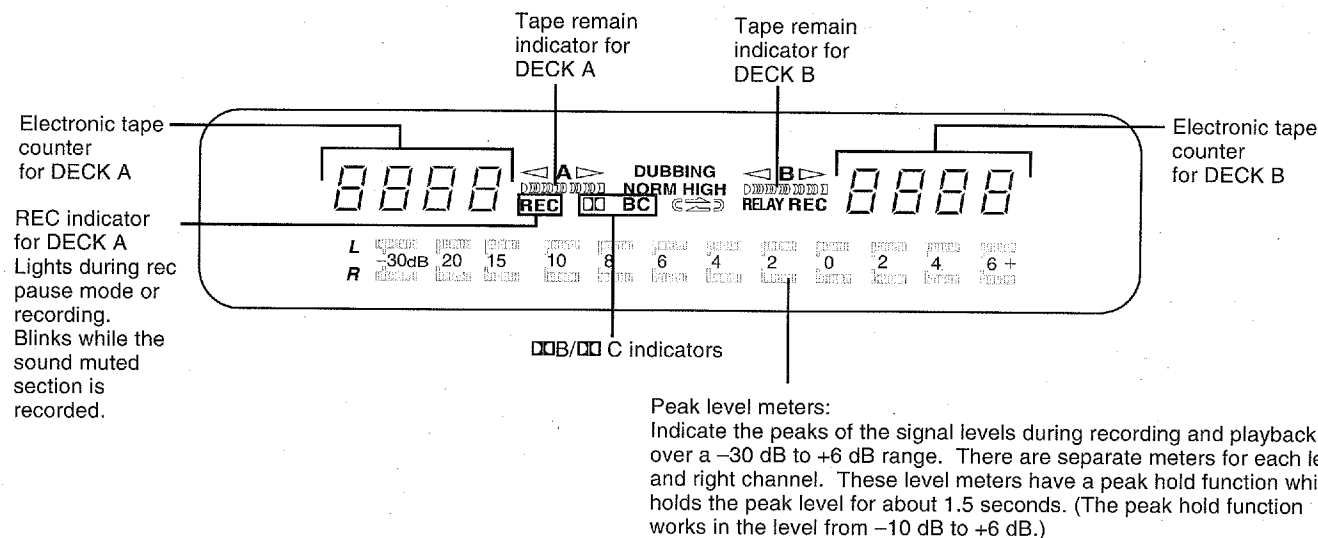

REVERSE MODE selector setting (in step 5)

The quick auto reverse function allows the tape running direction be reversed automatically. Select an auto reverse mode (↔, ⇄, or ↻ RELAY) or manual reverse mode (↔).

↔: When recording of one side of a tape is finished, the deck stops at the end of the tape.

⇄ or ⇄: Both sides of the tape are recorded. After recording, the deck stops at the end of the tape. (When the tape running direction is set to <, only the reverse side is recorded.)

↻ RELAY: Cassette tapes loaded in DECKs A and B are recorded sequentially. (See "RELAY RECORDING" on page 11.) If a cassette tape is loaded in either one of the DECK A or DECK B, the tape is recorded in the same way as the ⇄ mode.

- "↔" appears during recording in ⇄ mode.
- "↔ RELAY" appears during recording in ↻ RELAY mode.

Setting the recording level (in step 7)

Play the loudest passage of the source to be recorded and watch the meter readings. When using Normal position tapes (type I/NORM) or High position tapes (type II/HIGH (CrO₂)), adjust the REC LEVEL control so that the highest peak is +4 dB. When using Metal position tapes (type IV/METAL), adjust the REC LEVEL control so that the highest peak is +6 dB. (Refer to the figure below.)

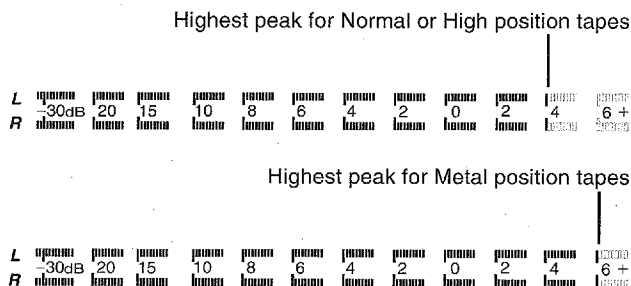

Electronic tape counter

Use the electronic tape counter to aid in locating a point on a tape (0000 to 9999). To set the counter reading to "0000", press the COUNTER RESET button.

To stop recording temporarily

Press the REC/PAUSE button. To resume recording, press the PLAY button.

To stop recording and remove the cassette tape

Press the STOP button and then the △ button. The cassette tray comes out and you can remove the cassette tape.

To turn off the power

Press the POWER switch again.

Tape remain indicator

Regardless of the tape running direction, the tape remain indicator shows the remaining length of the loaded tape to be recorded. It will be indicated after a few seconds when the loaded tape is forwarded.

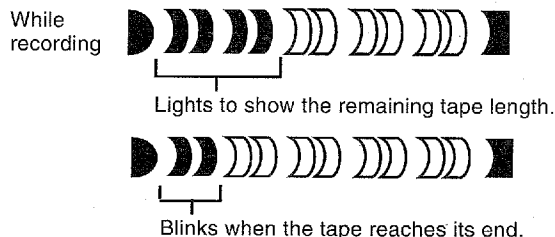

Note:

The tape remain indicator may differ depending on the tape length, tape type or the size of hub. So, use this indicator as an aid to recognize the remaining length of the tape to be recorded.

SYNCHRONIZED RECORDING FUNCTION — Recording CD automatically

When operating this unit in combination with the YAMAHA CD Player which has SYNCHRO button on its remote control transmitter, CD Synchronized recording function can be utilized. This function is operated with the remote control transmitter of the CD Player and effective for the deck selected with the DECK A/B button. (Regarding the operation, refer to the manual of the CD Player.)

AUTO REC MUTE OPERATION — Inserting a blank space during recording

During recording



A 4-second blank interval is automatically recorded on the tape, and then the deck enters rec pause mode. To resume recording, press the PLAY button. If a blank interval longer than 4 seconds is desired, keep pressing for as long as you want. When the MUTE/SEARCH button is released, the deck enters rec pause mode after making a 4-second blank interval. If a blank interval shorter than 4 seconds is desired, press the PLAY button during rec mute mode. Recording is resumed from the point.

REC RETURN OPERATION — To return to the point at which the recording previously started

During recording or rec pause mode

When the > tape
running indicator is lit:



When the < tape
running indicator is lit:



The tape will be rewound to the point at which the recording previously started, and it stops. Press the REC/PAUSE button and then the PLAY button to resume recording.

- If the PLAY button is pressed during recording, rec return operation automatically rewinds the tape to the point where the PLAY button was pressed at the last.
- If the COUNTER RESET is pressed and the counter is reset during recording, the tape will be returned to the point at which the COUNTER RESET was pressed.

VARIOUS FUNCTIONS HELPFUL FOR HIGH QUALITY RECORDING

AUTO TAPE SELECTOR

This deck has a built-in Auto Tape Selector which automatically adjusts the recording characteristics according to the tape formulation (see page 14).

DOLBY HX PRO DYNAMIC BIAS SERVO SYSTEM

This unit incorporates the Dolby HX Pro system which automatically controls the effective bias to reduce distortion and noise, improving high frequency response during recording. Tapes recorded with this system retain the same high quality even when played back on other cassette decks.

Dolby noise reduction and HX Pro headroom extension manufactured under license from Dolby Laboratories Licensing Corporation, HX Pro originated by Bang & Olufsen.

"DOLBY", the double-D symbol  and "HX PRO" are trademarks of Dolby Laboratories Licensing Corporation.

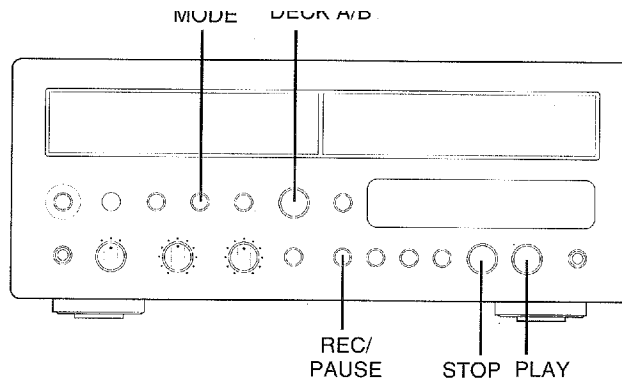

RELAY RECORDING — To record a program source sequentially on DECK A and DECK B

Recording can be made sequentially on DECKs A and B. Start the relay recording always from the cassette in DECK A.

- 1 Insert cassette tapes in both DECKs A and B.
 - 2 Press the DECK A/B to select DECK A. (The DECK A indicator lights on the display.)
 - 3 Perform steps 3 and 4 of "RECORDING" on page 8 to set the DOLBY NR, and the tape running direction
 - 4 Set the REVERSE MODE button to the \leftrightarrow RELAY mode, and perform steps 6 and 7 of "RECORDING" on page 8 to enter the rec pause mode and adjust the recording level.
 - 5 Press the PLAY button to start recording.
- The settings of the Dolby NR, reverse mode, and recording level for DECK B will be the same as those set for DECK A.
 - To record on both sides of the tapes, rewind them to the beginning of the forward side and select forward (\triangleright) direction with the DIRECTION button respectively. When reverse (\triangleleft) is selected, the source is recorded only on the reverse side.

DUAL RECORDING — To record a program source on both decks simultaneously

This function is useful for recording a program source on both decks simultaneously. To make the same recording, be sure to load the cassettes with the same length and quality.

- 1 Insert cassette tapes in both DECKs A and B.
 - 2 Press the DECK A/B button to select DECK A. (The DECK A indicator lights on the display.)
 - 3 Perform steps 3 through 5 of "RECORDING" on page 8 to set the DOLBY NR, the tape running direction, and the reverse mode. (When the \leftrightarrow RELAY mode is selected, the tapes are recorded in the same way as the \leftrightarrow mode.)
 - 4 Press the REC/PAUSE button.
 - 5 Play the program source to be recorded and adjust the recording level. (Refer to step 7 on page 8.)
 - 6 Press the DECK A/B button to select DECK B. The DECK B indicator lights on the display. Select the running direction. The settings of the Dolby NR, reverse mode and recording level are the same as those set for DECK A.
 - 7 Press the REC/PAUSE button to enter the rec pause mode. (The REC indicator of the DECK B lights.)
 - 8 To start recording, press the PLAY button. DECKs A and B start recording simultaneously.
- Once the dual recording starts, pressing the REC/PAUSE or STOP button or performing the AUTO REC RETURN /REC MUTE operation affects both decks simultaneously.
 - To obtain high quality recording, be sure to load the same type of cassette to both decks.

To stop recording temporarily

Press the REC/PAUSE button. To resume recording, press the PLAY button.

To stop recording in the middle of the tape

Press the STOP button, and both decks stop simultaneously.

Preparation for dubbing

- Turn on the POWER switch.
- Set your amplifier to cassette deck function mode.
- Open the cassette compartments by pressing the EJECT buttons and load a blank cassette tape in DECK A and the original cassette tape in DECK B.

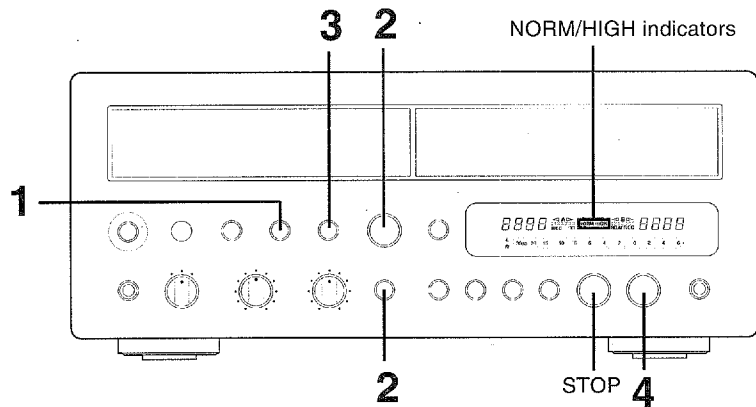

<p style="text-align: center;">1</p> <p style="text-align: center;">REVERSE MODE</p> <p style="text-align: center;">Set the REVERSE MODE selector. (Refer to page 9)</p>	<p style="text-align: center;">2</p> <p style="text-align: center;">DECK A/B DIRECTION</p> <p style="text-align: center;">Set the DECK A/B and DIRECTION buttons for DECKs A and B as desired.</p>	<p style="text-align: center;">3</p> <p style="text-align: center;">DUB MODE A-<B</p> <p style="text-align: center;">The corresponding NORM or HIGH indicator lights on the display.</p> <p style="text-align: center;">Set the dubbing speed to either NORM (normal speed) or HIGH (2 times normal speed) with the DUB MODE button.</p> <ul style="list-style-type: none"> ● Higher quality sound will be obtained with the NORM position. 	<p style="text-align: center;">4</p> <p style="text-align: center;">PLAY</p>
---	--	--	---

To stop dubbing

Press the STOP button. When DECK A has been selected with the DECK A/B button, both decks stop simultaneously and the dubbing mode is cancelled. When DECK B has been selected with the DECK A/B button, DECK B stops immediately and DECK A stops after providing a blank section of about 4 seconds.

When the tape in DECK A reaches its end, DECK A and DECK B stop at the same time.

When the tape in DECK B reaches its end, DECK B stops and DECK A stops after providing a blank section of about 4 seconds.

During dubbing

Rec Return function is available for the DECK A.

The <</> buttons can be used only for rewinding of the DECK A.

Note

- During dubbing, the Dolby NR is automatically set to OFF and the recorded tape can be dubbed as it is. (When the tape to be dubbed is recorded with Dolby NR, the Dolby NR effect is also dubbed.)

PLAY TRIM control adjustment

For normal use, set the PLAY TRIM control to the center position.

When the high frequencies sound is too noticeable or too weak while monitoring the sound during dubbing, compensate the high frequency response with the PLAY TRIM control. The compensated sound can be dubbed onto DECK A. This function is more effective in normal dubbing mode.

As the compensation result depends on the quality of the tape loaded in DECK A, the monitored sound cannot be recorded as it is.

Refer to PLAY TRIM control adjustment on page 6.

TIMER RECORDING/PLAYBACK

With a commercially available audio timer it is possible to make recordings and initiate playback automatically at any time.

Make sure that all power cord connections between the timer and amplifier/receiver are properly made.

For details, refer to the instructions of your audio timer. No change in any of the other connections between the deck and amplifier/receiver, etc., is necessary.

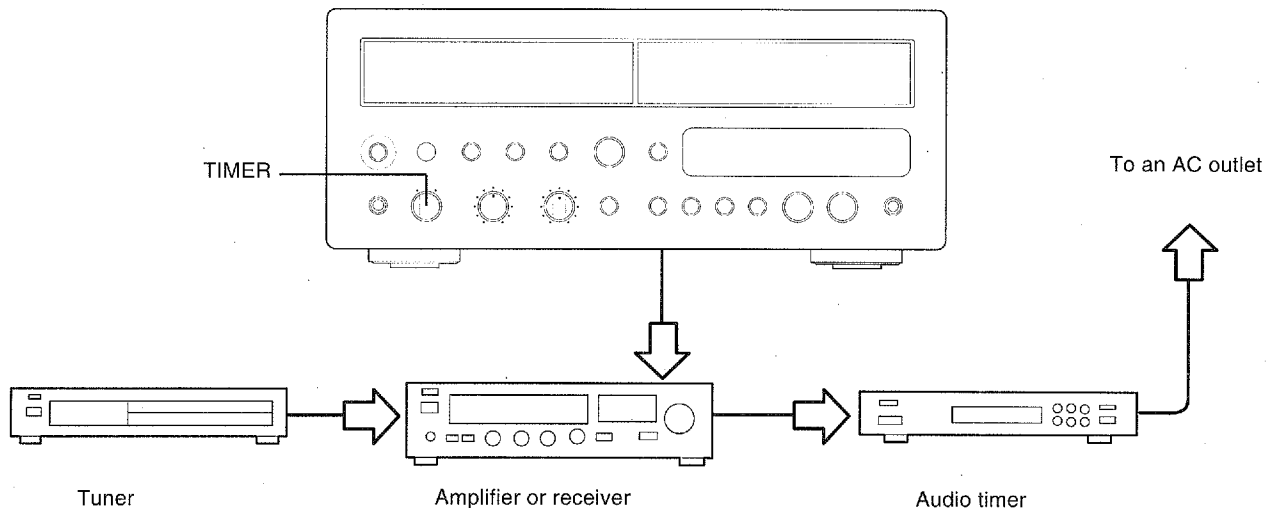

Timer recording

- 1 After turning on the power to each component, select the station on your tuner which you want to record and turn down the volume on your amplifier/receiver. This will have no effect on the recording signal level. Remember to set the proper recording level.
- 2 Set the timer to the desired recording start and stop times. It is advisable to set the timer to begin recording slightly before and end slightly after the actual broadcast receiving time to leave some room for later editing.
- 3 Set the TIMER switch to the REC position.

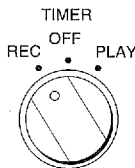

- 4 The timer will send power to the amplifier/receiver, tuner and deck at the preset time, turning all the components on and initiating the recording. When the preset time is reached, the power is turned off.

- Recording starts on the deck which has been selected with the DECK A/B button.

Note:

Whenever the timer recording/playback is not intended, make sure to set the TIMER switch to OFF position to prevent the unnecessary recording/playback.

- If the TIMER switch is set to REC position and the power is supplied (plugging in the power cord or automatically supplying the power after power failure, etc.), the deck automatically enters REC mode and the contents of the cassette tape inserted in the deck will be erased.

Timer playback

- 1 Turn on the amplifier/receiver and adjust the volume and tone controls.
- 2 Set the input mode selector of your amplifier/receiver to the cassette deck function mode.
- 3 Set the timer to the time you wish to start and stop playback.
- 4 Set the TIMER switch to the PLAY position.

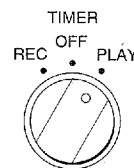

- 5 At the preset time, the timer will turn power on to the amplifier/receiver and cassette deck and begin playback.

- Playback starts on the deck which has been selected with the DECK A/B button. If no tape is loaded in the selected deck, the other deck starts playback.

CASSETTE TAPES

There are many different types of cassette tapes available. However, they all conform to standard specifications so any brand may be used with the deck.

Classification of Cassette Tapes by Formulation
Cassette tapes are available in four basic types depending on their formulation, or type of magnetic material and manufacturing process. These four types are commonly known as Normal (Type I/NORM), Chrome (Type II/HIGH $\langle\text{CrO}_2\rangle$), Ferrichrome (Type III/FeCr), and Metal (Type IV/METAL), and they each require specific tape deck adjustments for optimum performance.

* YAMAHA does not recommend the use of 120-minute length cassettes since the extreme thinness of the tape makes them susceptible to mechanical and recording problems.

AUTO TAPE SELECTOR DETECTION SLOTS

The deck has a built-in Auto Tape Selector which automatically adjusts for the proper bias, level and equalization according to the tape formulation — all you have to do is to load a cassette and the Auto Tape Selector does the rest.

The Auto Tape Selector determines what type of tape is loaded by sensing detector slots on top of the tape shell. Each tape formulation has its own characteristic hole markings standardized by the tape industry.

Early model Metal (Type IV/METAL) tape formulation cassette shells do not have the slots for Auto Tape Selector operation. As a result, early model Metal type tapes recorded on another deck will be played back with the deck at the Chrome (Type II/HIGH $\langle\text{CrO}_2\rangle$) settings. YAMAHA does not recommend recording with this kind of tape.

The deck does not have the required setting for Ferrichrome (Type III/FeCr) tape, since this tape formulation is not widely used. Should you use a Ferrichrome tape, it will be recorded and played back at the Normal (Type I/NORM) settings, which will result in an unnatural high frequency emphasis. This effect may be compensated for somewhat with the auto tape tuning operation or by using the PLAY TRIM tone control and/or the tone controls of your amplifier/receiver during playback.

TYPE II

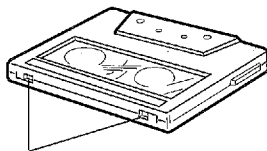

Detector slots

TYPE IV

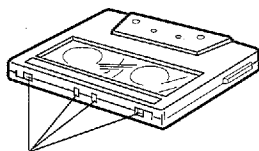

Detector slots

PROTECTING YOUR RECORDINGS

All cassette tapes are provided with erasure protection holes to prevent accidental erasure of recorded contents. There is a small tab covering the hole on each side of the cassette, and it should be broken off after recording on the tape. Without this tab covering the hole, it is impossible to record onto that tape. Thus, you can safely protect a recording for as long as you wish without fear of accidental erasure. Should you wish to use a cassette tape protected in this way for recording, simply covering the hole with adhesive tape will permit erasure and re-recording.

When using Chrome (Type II/HIGH $\langle\text{CrO}_2\rangle$) or Metal (Type IV/METAL) tapes, make sure you do not cover the hole intended for the Auto Tape Selector operation.

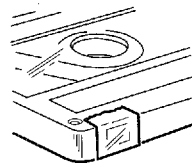
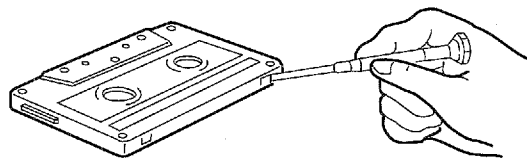

TAKING UP SLACK IN THE TAPE

As a precaution against tape entanglement and damage, remove any slack in the tape before inserting cassettes into the deck. This is accomplished by inserting a pencil, pen or similar object into one of the spools and gently winding it until all the slack is removed. You do not have to wind it too tightly.

Be careful not to touch the tape part itself. It is very delicate and touching it may damage the tape and its recorded contents.

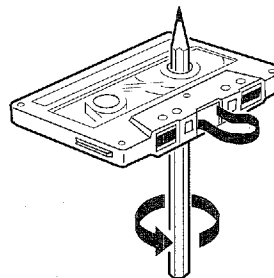

STORING CASSETTES

After putting a cassette tape back into its case, store it in a location away from exposure to direct sunlight, humidity, high temperatures, and magnetic fields (away from television sets, speakers, etc.). High temperatures and humidity will damage the tape itself, while exposure to magnetic fields may cause a loss of recorded material. Avoid touching the tape surface with your fingers, since dirt or finger oil will contaminate the deck's heads.

CLEANING OF THE TAPE PATH

Continued high quality performance of your deck is dependent upon periodic cleaning of the heads, capstan, pinch roller, and all surfaces over which the tape travels. Normal use will cause an accumulation of dirt and dust on the heads, capstans, and pinch rollers. This can lead to poor sound quality, drop outs (intervals with no sound), unsteady tape speed, loss of high frequency response, etc. Thus, clean the heads and all surfaces over which the tape travels with a commercially available cassette-shaped cleaning tape.

DEMAGNETIZATION

After 20-30 hours of use, enough residual magnetism will build up on the heads to cause poor high frequency reproduction. At this time you should use a commercially available cassette-shaped head demagnetizer.

- When demagnetizing the heads, be sure to follow the instructions of the head demagnetizer carefully.

REMOTE CONTROL TRANSMITTER

With the remote control transmitter supplied with the amplifier AX-10 or receiver RX-10, you can operate this unit at your listening position. For details, refer to the instruction manual supplied with the remote control transmitter.

REMOTE CONTROL OPERATION RANGE

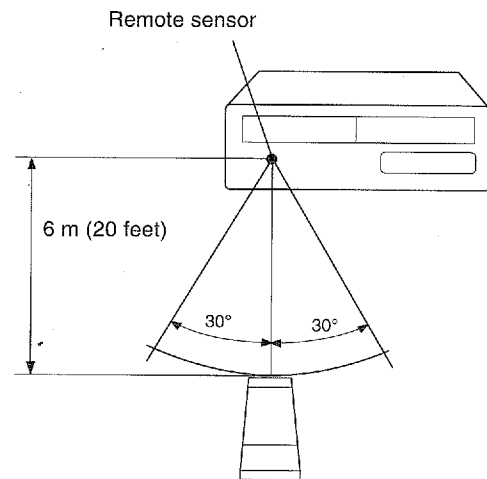
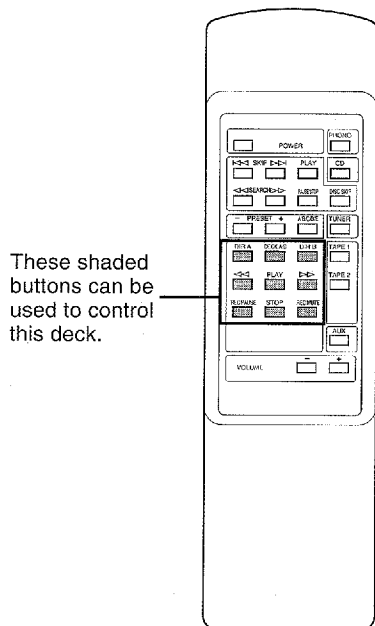

If your cassette deck fails to operate normally, check the following table. It lists common operating errors and simple measures which you can take to correct the problem. If it cannot be corrected, or the symptom is not listed, disconnect the deck's power cord and contact your authorized YAMAHA dealer or service center for help.

Fault	Cause	Cure
Tape doesn't move in recording or playback.	<ul style="list-style-type: none"> ● Power plug is not properly plugged in. ● End of tape. ● Cassette shell is warped or damaged. 	<ul style="list-style-type: none"> ● Reinsert plug properly. ● Rewind tape or flip it over. ● Do not play damaged tapes.
REC/PAUSE button fails to function.	<ul style="list-style-type: none"> ● No cassette tape is loaded. ● Protective tabs are broken off. 	<ul style="list-style-type: none"> ● Load a cassette tape. ● Change tape or cover protective hole with adhesive tape.
Sounds become faint and sometimes inaudible.	<ul style="list-style-type: none"> ● Head is dirty. ● Head is magnetized. ● Tape is damaged or of poor quality. 	<ul style="list-style-type: none"> ● Clean head. ● Demagnetize head using head demagnetizer. ● Change to a different tape.
Recorded sound is distorted.	<ul style="list-style-type: none"> ● Tape is bad (stretched or deformed, etc.). ● Cassette shell is warped. ● Recording level is too high. 	<ul style="list-style-type: none"> ● Replace with a fresh tape. ● A warped cassette shell cannot be fixed. Replace with another tape and test. ● Check input level with peak level meter and use lower rec level when recording.
Tape is playing back, but no sound is heard.	<ul style="list-style-type: none"> ● Faulty connection between deck and stereo amplifier/receiver. 	<ul style="list-style-type: none"> ● Check and secure connections.
Excessive noise.	<ul style="list-style-type: none"> ● Head is dirty. ● Head is magnetized. ● Worn out or poor quality tape. ● Connection(s) improperly made. ● Affected by external electrical noise. 	<ul style="list-style-type: none"> ● Clean head. ● Demagnetize head with head demagnetizer. ● Change to better tape. ● Check input and output connections and reinsert properly. ● Move away from electrical appliances (TV, fluorescent light, electric blanket, etc.).
Excessive wow (wavering of the sound).	<ul style="list-style-type: none"> ● Dirty capstan, pinch roller, etc., or poor tape. ● Tape is wound unevenly. 	<ul style="list-style-type: none"> ● Clean capstan or pinch roller, or change to better tape. ● Rewind tape.
Tape stops in the middle of recording or playback.	<ul style="list-style-type: none"> ● Slack tape, or tape spillage wound around capstan. 	<ul style="list-style-type: none"> ● Remove the wound tape carefully. To avoid this, insert pencil in hole in cassette shell and turn to take up slack in advance.
Fails to record.	<ul style="list-style-type: none"> ● REC LEVEL control is set too low. ● Protective tabs are broken off. 	<ul style="list-style-type: none"> ● Adjust REC LEVEL control. ● Change tape or cover protective hole with adhesive tape.
Search does not operate.	<ul style="list-style-type: none"> ● Recorded section is too short. ● Recorded section has low-level portions. ● Conversation, etc. has been recorded. ● The section is recorded with fad-in or fade-out function. 	<ul style="list-style-type: none"> ● Blank sections must be at least 4 seconds long.
High frequencies in the playback sound are emphasized and unpleasant to listen to, and noise level (hiss) is also high.	<ul style="list-style-type: none"> ● Dolby NR-recorded tape is played back in OFF position. ● The PLAY TRIM control is not set properly. 	<ul style="list-style-type: none"> ● Playback in appropriate Dolby NR position. ● Adjust the PLAY TRIM control properly.

Fault	Cause	Cure
Playback sound is muffled and high frequencies are inaudible.	A tape recorded without Dolby NR is played back with Dolby NR on. Heads are dirty. Heads are magnetized.	Playback in OFF position. Clean heads and carry out demagnetization with head demagnetizer.
When playing back tapes recorded on other decks, meter deflections are greater (smaller) than when recording.	Basic levels are different for different cassette decks.	This is not a fault.

SPECIFICATIONS

Track Configuration	4 track, 2 channel stereo
Motor	DC servo motor (main) x 2 DC motor (tray) x 2
Head	Recording/playback: hard permalloy x 2 Erase: double-gap Ferrite x 2
Rapid Transport	120 sec. (C-60)
Wow and Flutter	
W.RMS	less than 0.09%
W.Peak	less than $\pm 0.19\%$
Signal-to-Noise Ratio	
(Dolby NR off)	better than 58 dB
(Dolby B NR on)	better than 66 dB
(Dolby C NR on)	better than 74 dB
Frequency Response	
Normal tape (-20 dB)	30 - 16,000 Hz ± 3 dB
High (CrO ₂) tape (-20 dB)	30 - 17,000 Hz ± 3 dB
Metal tape (-20 dB)	30 - 19,000 Hz ± 3 dB
Harmonic Distortion	less than 1.2%
Input Sensitivity/Impedance	
Line	100 mV/50 k-ohms
Output Level	
Line	570 mV/2.2 k-ohms
Channel Separation (1 kHz)	40 dB
Cross Talk (125 Hz)	55 dB

GENERAL

Power Supplies

Europe and U.K. models 230 V, 50 Hz

Australia model 240 V, 50 Hz

General model 110/120/220/240 V, 50/60 Hz

Power Consumption 16 W

6 W (POWER OFF)

Dimensions (W x H x D) 280 x 119 x 360 mm

(11 x 4-11/16" x 14-3/16")

Weight 5.8 kg (12 lbs. 13 oz.)

Accessories

Connecting cords 2

* Specifications subject to change without notice.

This product complies with the radio frequency interference requirements of the Council Directive 82/499/EEC and/or 87/308/EEC.

Cet appareil est conforme aux prescriptions de la directive communautaire 87/308/CEE.

Diese Geräte entsprechen der EG-Richtlinie 82/499/EWG und/oder 87/308/EWG.

Denne apparat overholder det gældende EF-direktiv vedrørende radiostøj.

Questo apparecchio è conforme al D.M. 13 aprile 1989 (Direttiva CEE/87/308) sulla soppressione dei radiodisturbi.

Este producto está de acuerdo con los requisitos sobre interferencias de radio frecuencia fijados por el Consejo Directivo 87/308/CEE.

Dit produkt is gefabriceerd in overeenstemming met de radiostoringsvoorschriften van de Richtlijn van de Raad (82/499/EGG).

YAMAHA

YAMAHA ELECTRONICS CORPORATION, USA 6660 ORANGETHORPE AVE., BUENA PARK, CALIF. 90620, U.S.A.
YAMAHA CANADA MUSIC LTD. 135 MILNER AVE., SCARBOROUGH, ONTARIO M1S 3R1, CANADA
YAMAHA ELECTRONIK EUROPA G.m.b.H. SIEMENSSTR. 22-34, 25462 RELLINGEN, BEI HAMBURG, F.R. OF GERMANY
YAMAHA ELECTRONIQUE FRANCE S.A. RUE AMBROISE CROIZAT BP70 CROISSY-BEAUBOURG 77312 MARNE-LA-VALLEE CEDEX02, FRANCE
YAMAHA ELECTRONICS (UK) LTD. YAMAHA HOUSE, 200 RICKMANSWORTH ROAD WATFORD, HERTS WD1 7JS, ENGLAND
YAMAHA SCANDINAVIA A.B. J A WETTERGRENS GATA 1, BOX 30053, 400 43 VASTRA FRÖLUNDA, SWEDEN
YAMAHA MUSIC AUSTRALIA PTY, LTD. 17-33 MARKET ST., SOUTH MELBOURNE, 3205 VIC., AUSTRALIA

YAMAHA CORPORATION

VT 56510

Printed in Malaysia